



File In Section: Product Recalls
Bulletin No.: 11142
Date: May 2011

Recall Bulletin



F/CMVSS NONCOMPLIANCE RECALL

SUBJECT: Shift Lever May Not Display Correct Gear

MODELS: 2011 Chevrolet Cruze
Equipped with an Automatic Transmission

CONDITION

General Motors has decided that certain 2011 model year Chevrolet Cruze vehicles equipped with an automatic transmission may fail to conform to Federal/Canada Motor Vehicle Safety Standard 102, Transmission Shift Position Sequence, Starter Interlock, and Transmission Braking Effect, and Standard 114, Theft Protection and Rollaway Prevention. These vehicles may have been built with a transmission shift linkage that is not properly seated. If the linkage is not properly seated, the PRNDL shift lever may not accurately reflect the position of the transmission gear. With this condition, the driver could move the shifter to PARK and remove the ignition key, but the transmission gear may not be in PARK. The driver may not be able to restart the vehicle and the vehicle could roll away after the driver has exited the vehicle, resulting in a possible crash without prior warning.

CORRECTION

Dealers are to inspect the position of the transmission shift linkage and, if necessary, realign the linkage.

VEHICLES INVOLVED

Involved are **certain** 2011 model year Chevrolet Cruze vehicles equipped with an automatic transmission.

Important: Dealers are to confirm vehicle eligibility prior to beginning repairs by using the Required Field Actions section in the Global Warranty system. Not all vehicles may be involved.

For dealers with involved vehicles, a listing with involved vehicles containing the complete vehicle identification number, customer name, and address information has been prepared and will be provided to US and Canadian dealers through the GM GlobalConnect Recall Reports. Dealers will not have a report available if they have no involved vehicles currently assigned.

The listing may contain customer names and addresses obtained from Motor Vehicle Registration Records. The use of such motor vehicle registration data for any purpose other than follow-up necessary to complete this recall is a violation of law in several states/provinces/countries. Accordingly, you are urged to limit the use of this report to the follow-up necessary to complete this recall.

PART INFORMATION

Parts required to complete this program are to be obtained from General Motors Customer Care and Aftersales (GMCC&A). Please refer to your "involved vehicles listing" before ordering parts. Normal orders should be placed on a DRO = Daily Replenishment Order. In an emergency situation, parts should be ordered on a CSO = Customer Special Order.

Part Number	Description	Quantity/Vehicle
22847616*	Adjuster, A/Trns Range Sel Lvr Cbl	1 (If Req'd)
11612155*	Lock, A/Trns Range Sel Lvr Cbl Adj	1 (If Req'd)

* It is estimated that less than 10% of involved vehicles will require replacement. Please order parts accordingly.

SERVICE PROCEDURE

1. Set the park brake and chock the wheels.
2. Open the hood.

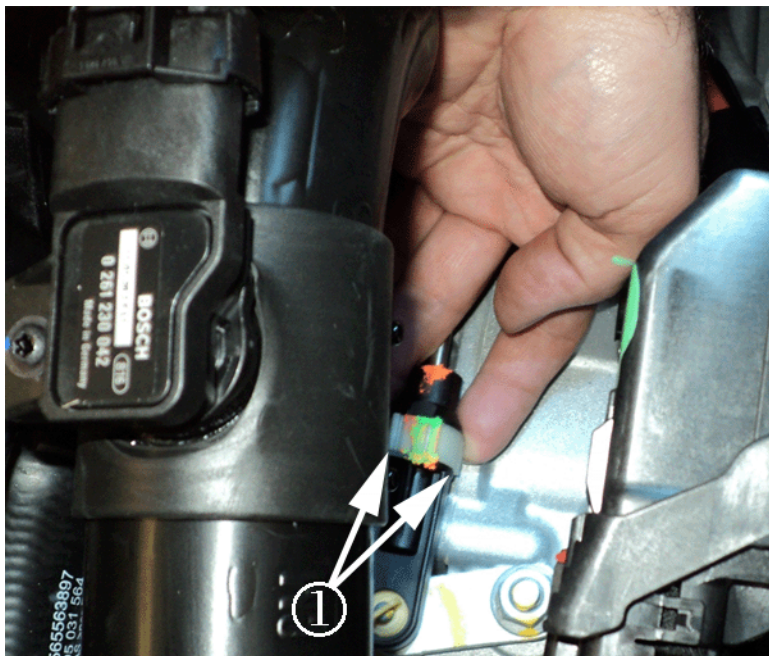

3. Place index and middle fingers under edges of the white transmission range selector lever cable adjust lock (locking clip) (1) on top of shifter arm assembly. Attempt to lift both sides of the white clip out of the shifter arm linkage to validate the white clip is fully seated. If the white clip is fully seated, it will NOT lift out of the shifter arm linkage assembly.
4. If the white locking clip lifts out of its locked position, replace the clip. Install a new clip, seating it firmly, and repeat the test.

Note: The white locking clip will produce a notable click when it is properly seated and snapped into place. Ensure that the adjust lock "clicks" into its locked position.

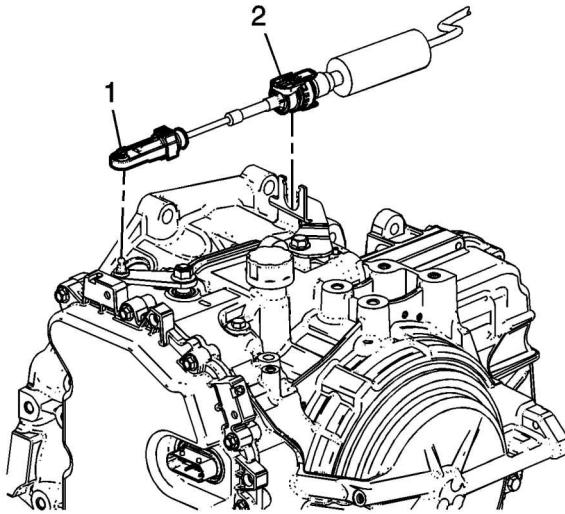

2001179

5. If the new clip lifts out of its locked position, replace the transmission range selector lever cable adjuster (terminal) (1).
6. Disconnect the transmission range selector lever cable terminal (1) from the transmission manual shift lever pin.
7. Press the locking tabs inward in order to release the transmission range selector lever cable (2) from the cable bracket.
8. If a new transmission range selector lever cable terminal (1) was determined to be required in Step 5, lift up and remove the white locking clip which will release the cable terminal from the cable. Install a new cable terminal and install the white locking clip to the cable in its adjust position.

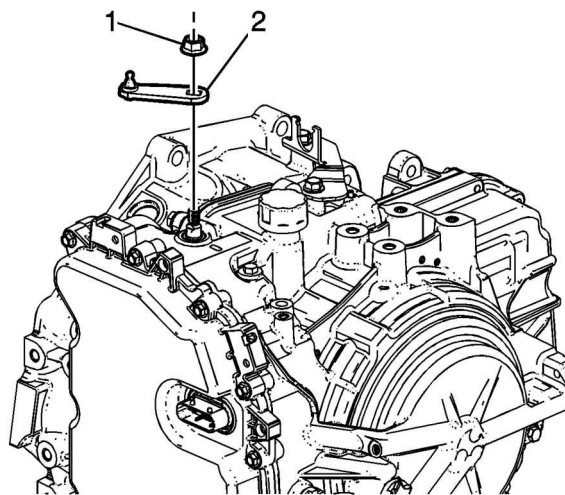

2001183

Warning: Hold the transmission range selector lever while removing or installing the lever retaining nut. Excessive torque on the manual shaft can damage the detent lever hub retainer which could allow the vehicle to roll when placed in the park position.

9. Remove the transmission range selector nut (1).

10. Remove the transmission range selector lever (2)

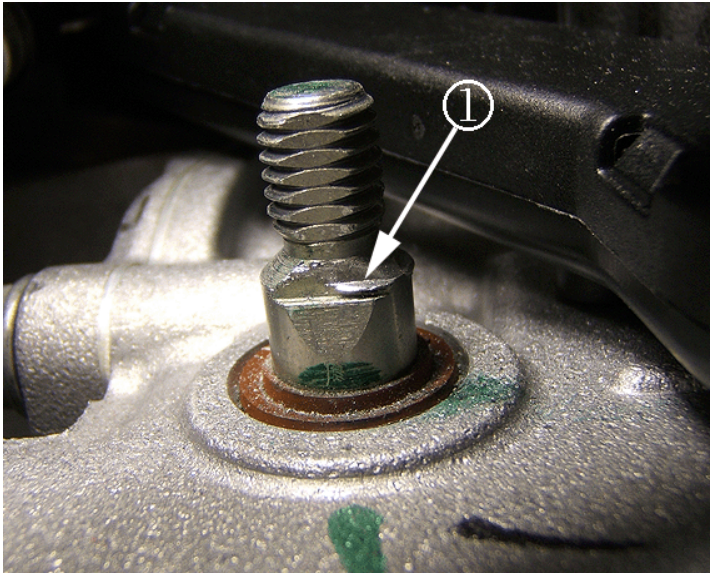

2647515

11. Inspect the flats on both sides of the transmission manual shaft for a burr or metal ridge (1). If a burr exists continue below, otherwise skip to Step 20.

Caution: The following step **MUST** be performed with a flat fine cut metal file **ONLY**. **DO NOT** use a die grinder or any power tool for this operation. Removing excess material beyond the intended described repair may cause excessive play in the transmission manual shaft requiring its replacement.

12. Turn the transmission manual shaft to a position that provides the best access and allows you to place the file as flat to the shaft as possible. A shorter file is desirable due to limited space around the transmission manual shaft

Caution: When performing this operation it is best to remove the burr in several small attempts. The file will quickly remove the burr. Caution must be exercised not to remove too much material creating an undersized condition of the shaft. In all cases, the transmission manual shaft should be made useable by this procedure.

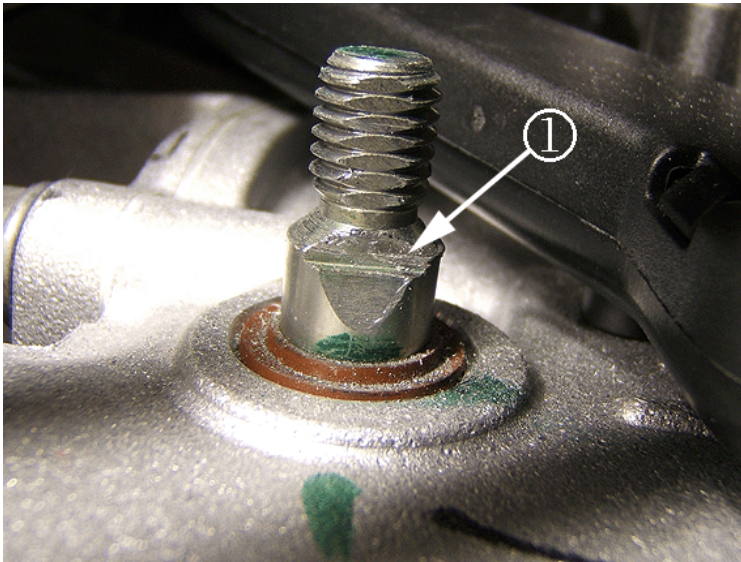

2647520

13. Remove any burr or ridge with a flat metal file, being careful to remove the minimal amount of material required to restore and true the flat on the transmission manual shaft. The flat should feel smooth to the touch; however there may be some visual remnant (1) of the burr. This is acceptable as long as a true flat side now exists.

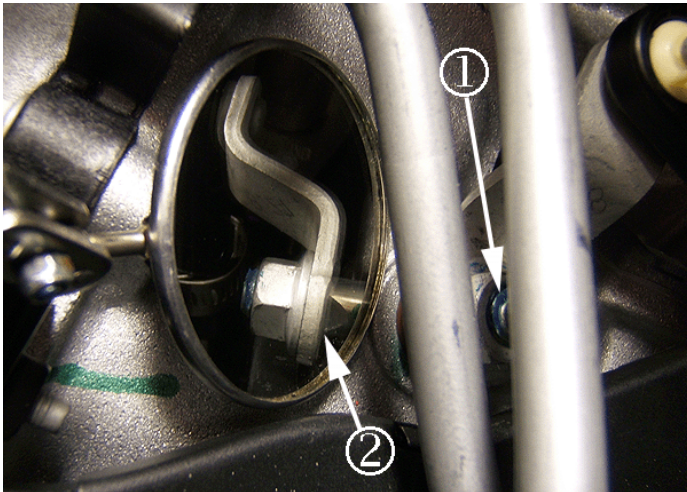

2651712

14. Install the transmission range selector lever to the transmission manual shaft. Confirm that the lever now seats completely on the transmission manual shaft and is no longer elevated above the shaft seat by the burr. Verify the lever is properly seated (1) using a mechanics mirror (2). If the transmission range selector lever still does not fully seat, very lightly, finesse the burr with a file again, install and verify.
15. Using compressed air, blow away the metal shavings.

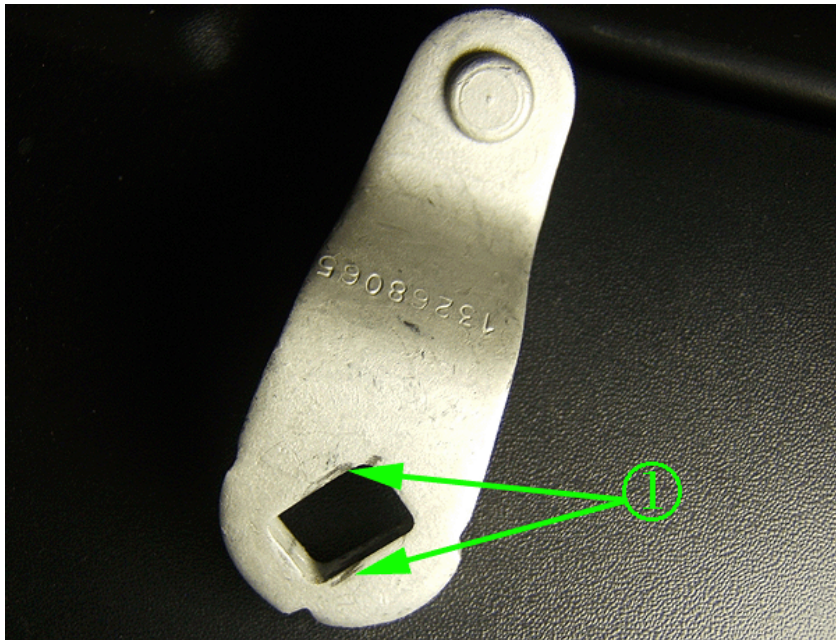

2650633

16. Remove and examine the transmission range selector lever. Confirm that the rectangular receiver in the lever has not been deformed. It is expected that a witness mark (1) on the bottom of the lever may exist (as shown) from contact with the now removed burr. Minor marks at the edge of the receiver will not affect proper operation. Only replace the lever if significant (easily seen) deformation / rounding of the receiver hole exists

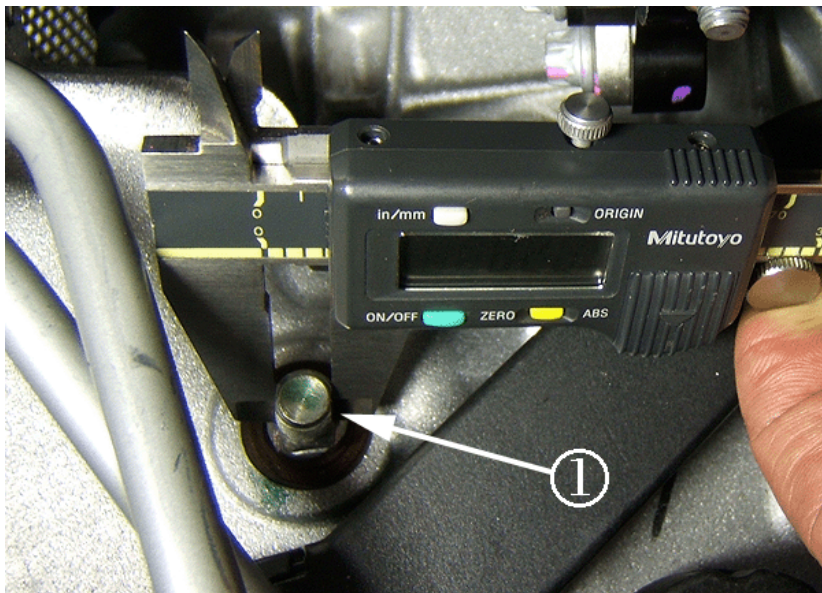

2650652

17. Using a caliper measure the distance across the flats of the transmission manual shaft.

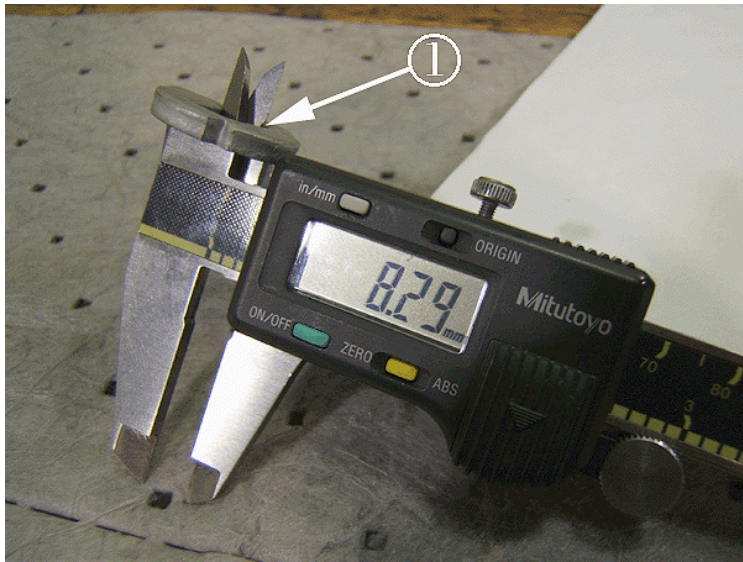

2650656

18. Using a caliper, measure the inside of the transmission range selector lever rectangular receiver (1).
19. The difference between the readings across the flats of transmission manual shaft and the inside diameter of the levers mating surface must not be more than 0.2 millimeters or the transmission manual shaft must be replaced.

Example: If the transmission manual shaft measures 8.18mm and the inside diameter of the levers mating surface measures 8.29mm as shown above, the difference is 0.11mm and an acceptable fit.

Caution: IF MEASURED CLEARANCE EXCEEDS 0.2MM, REPLACEMENT OF THE MANUAL SHAFT IS NECESSARY. REFER TO THE "MANUAL SHIFT DETENT LEVER WITH SHAFT POSITION SWITCH ASSEMBLY REPLACEMENT" PROCEDURE IN SI. IF REPLACEMENT IS REQUIRED, SUBMIT REPLACEMENT UNDER NORMAL WARRANTY.

Warning: Hold the transmission range selector lever while removing or installing the lever retaining nut. Excessive torque on the manual shaft can damage the detent lever hub retainer which could allow the vehicle to roll when placed in the park position.

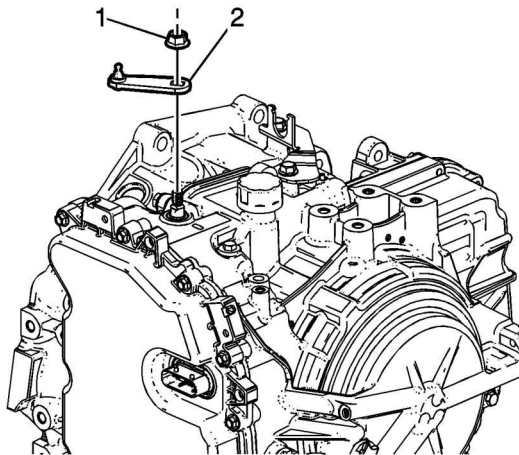

2001183

20. Apply blue medium strength threadlocker (GM P/N 12345382, LOCTITE 242, or LOCTITE 248) to the threads of the transmission manual shaft.

21. Install the transmission range selector lever (2) and nut (1). Tighten the nut to 30 N·m (22 lb-ft).

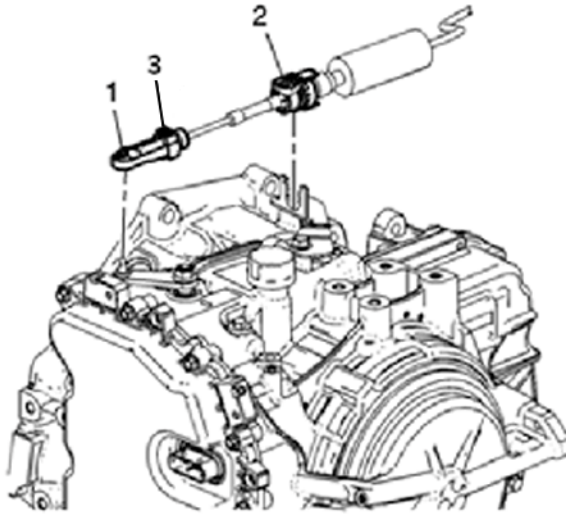

2637195

22. Lift the transmission range selector lever cable adjust locking clip (3) to the adjustment position.
 23. Install the transmission range selector lever cable (2) to the cable bracket.
 24. Connect the transmission range selector lever cable terminal (1) to the transmission manual shift lever pin.
 25. Verify that the transmission range selector lever is in the park position.
 26. Verify that the transmission shift lever is in the park position.
- Note:** The adjust lock will produce a notable click when it is properly seated and snapped into place. Ensure that the adjust lock "clicks" into its locked position.
27. Install (press down firmly and lock) the range selector lever cable adjust lock (1).
 28. Check the transmission range selector lever in all gear selections for proper operation.

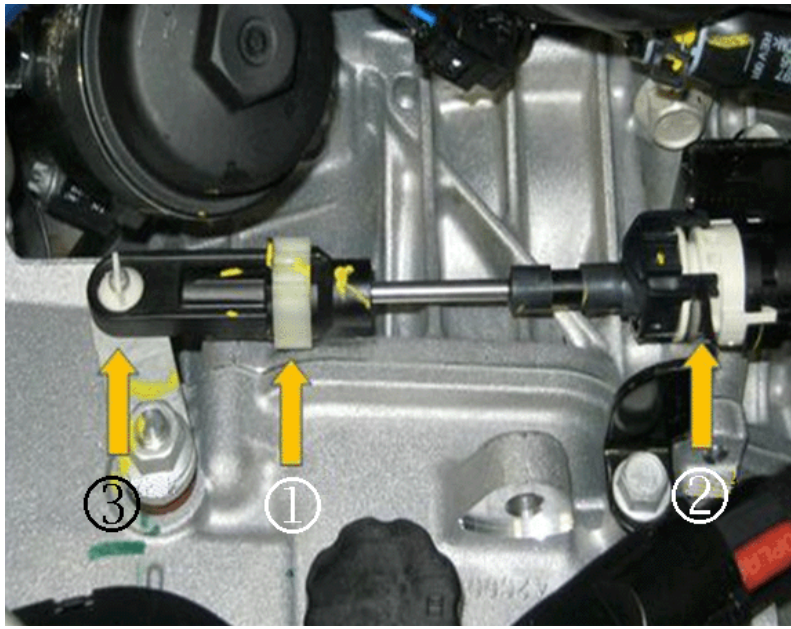

29. Confirm that the white locking clip (1), the transmission selector cable to cable bracket (2), and the cable terminal to manual shift lever pin (3) are all secured.
30. Close the hood.
31. Disengage the park brake and remove the wheel chocks.

COURTESY TRANSPORTATION

The General Motors Courtesy Transportation program is intended to minimize customer inconvenience when a vehicle requires a repair that is covered by the New Vehicle Limited Warranties. The availability of courtesy transportation to customers whose vehicles are within the warranty coverage period and involved in a product program is very important in maintaining customer satisfaction. Dealers are to ensure that these customers understand that shuttle service or some other form of courtesy transportation is available and will be provided at no charge. Dealers should refer to the General Motors Service Policies and Procedures Manual for Courtesy Transportation guidelines.

WARRANTY TRANSACTION INFORMATION

Submit a transaction using the table below.

Labor Code	Description	Labor Time
V2428	Inspect & Adjust Transmission Range Selector Lever & Cable - Lever Not Seated Properly	0.6
V2429	Inspect & Adjust Transmission Range Selector Lever & Cable - Lever Seated Properly	0.5

CUSTOMER NOTIFICATION

General Motors will notify customers of this recall on their vehicle.

DEALER RECALL RESPONSIBILITY – For US (US States, Territories, and Possessions)

The US National Traffic and Motor Vehicle Safety Act provides that each vehicle that is subject to a recall of this type must be adequately repaired within a reasonable time after the customer has tendered it for repair. A failure to repair within sixty days after tender of a vehicle is prima facie evidence of failure to repair within a reasonable time. If the condition is not adequately repaired within a reasonable time, the customer may be entitled to an identical or reasonably equivalent vehicle at no charge or to a refund of the purchase price less a reasonable allowance for depreciation. To avoid having to provide these burdensome remedies, every effort must be made to promptly schedule an appointment with each customer and to repair their vehicle as soon as possible. In the recall notification letters, customers are told how to contact the US National Highway Traffic Safety Administration if the recall is not completed within a reasonable time.

This bulletin is notice to you that the new motor vehicles included in this recall may not comply with the standard identified above. Under Title 49, Section 30112 of the United States Code, it is illegal for a dealer to sell a new motor vehicle which the dealer knows does not comply with an applicable Federal Motor Vehicle Safety Standard. As a consequence, if you sell any of these motor vehicles without first performing the recall correction, your facility may be subject to a civil penalty for each such sale.

DEALER RECALL RESPONSIBILITY - All

All unsold new vehicles in dealer's possession and subject to this recall must be held and inspected/repaired per the service procedure of this recall bulletin before customers take possession of these vehicles.

Dealers are to service all vehicles subject to this recall at no charge to customers, regardless of mileage, age of vehicle, or ownership, from this time forward.

Customers who have recently purchased vehicles sold from your vehicle inventory, and for which there is no customer information indicated on the dealer listing, are to be contacted by the dealer. Arrangements are to be made to make the required correction according to the instructions contained in this bulletin. Recall follow-up cards should not be used for this purpose, since the customer may not as yet have received the notification letter.

In summary, whenever a vehicle subject to this recall enters your vehicle inventory, or is in your facility for service in the future, you must take the steps necessary to be sure the recall correction has been made before selling or releasing the vehicle.

