



(Does not apply to Mack Trucks Australia)

Date	Number	Page
8/8/11	SC0352	1(2)

Gunite Automatic Slack Adjuster

CHU, CXU, GU, LEU, MRU

SC0352, Gunite Automatic Slack Adjuster

(August 2011)

Gunite has identified a safety related defect in certain slack adjusters manufactured from October 15, 2010 through January 31, 2011. The slack adjuster may have a flow notch in the handle, which under normal braking load may result in a broken housing. If this occurs, the brake at that wheel end may become inoperative, potentially increasing the vehicle's stopping distance, which may possibly result in a vehicle crash.

The recall involves inspection of vehicles in the affected population for slack adjusters with suspect lot number and mold line identifiers, and replacement if the information on the slack adjuster matches the suspect lot numbers and mold lines provided in the table on page 2 in the attached Gunite Service Advisory, GUN2.0014 Rev. 4.

This safety recall affects one thousand nine hundred five (1,905) 2011-2012 model MACK trucks produced with Gunite slack adjusters from October 20, 2010 - February 18, 2011.

Parts:

- Parts are available at MACK distribution warehouses.
- Removed parts can be scrapped locally **after rendering the slack adjuster inoperative as shown on pages 4 and 5** on the attached Gunite Service Advisory, GUN2.0014 Rev. 4.

Repair Procedures:

1. Park the vehicle on a level surface with the transmission in neutral and wheels chocked.
2. Use the attached Gunite Service Advisory, GUN2.0014 Rev. 4, to inspect all the slack adjusters on the vehicle to determine if one or more of the slack adjuster requires replacement.
3. Use the attached Gunite Service Manual when replacing slack adjusters. The slack adjusters used by MACK Trucks are the welded clevis type, which is covered on page 9 of the bulletin. This procedure **MUST** be followed in its entirety.
4. Check to see that slack adjuster and brakes are working correctly.
5. Render any removed slack adjusters inoperative as shown on pages 4 and 5 on the attached Gunite Service Advisory, GUN2.0014 Rev. 4, and locally dispose of the parts.

Reimbursement

This repair is covered by an authorized Safety Recall campaign. Reimbursement is obtained through the normal claim handling process.	
Claim Type (used only when uploading from the Dealer Bus. Says.)	40
Recall Status	
Vehicle inspected, repair not included	1- Inspected
Vehicle repaired per instructions	2-Modified per instructions
Labor Code	
Primary Labor Code for inspecting all slack adjusters	5172B-01-95 0.3
Labor code for each slack adjuster replaced	5172C-01-95 0.4
Time to take charge of vehicle and determine campaign status	101AA 0A 00— 0.3 hr.
Causal Part	3398-AS1168**
Authorization No.	SC0352

Take-charge time is not included in the labor code for this operation. Take charge may be eligible, but can only be used once per vehicle repair visit. If the vehicle is having other warranty repairs performed, take-charge should be charged to the warranty repair, otherwise take-charge can be charged to this Safety Recall.

NOTE

Dealers are to perform Safety Recall Campaigns on all subject vehicles at no charge to the vehicle owner regardless of mileage, age of vehicle or ownership (original purchaser or subsequent purchasers). Whenever vehicles are subject to a safety recall are brought to your dealership for service, or taken into your dealership vehicle inventory, it is strongly recommended that every effort be made to perform the recall correction before the vehicle is sold or released to the owner.

**Causal part number provided above for reference only.

5172B-01-95 Labor Code is for inspecting all slacks on vehicle to determine whether replacement is required.

Use 5172C-01-95 Labor Code if one or more slacks require replacement. For example, if two slacks require replacement, use 5172C-01-95 at 0.8 hr (2 slacks multiplied by 0.4 hr) in addition to the Primary Labor Code.

Gunite – Service Advisory

March 30, 2011

Catalogs & Brochures

Product & Education

Sales Promotion

Pricing

Technical & Trouble Shooting

Other

NO: GUN2.0014 Rev. 4

Gunite® Automatic Slack Adjuster Inspection Instructions

Use the following instructions to inspect your inventory or installed Gunite® Automatic Slack Adjusters.

1. Remove the automatic slack adjuster from the box and plastic shipping bag if product is in inventory.
2. Inspect the automatic slack adjuster in two locations to determine the lot number.
 - a. On the side of the slack adjuster housing you will see the name Gunite and either an "H" or "1H". See Figure A. This is the mold line nomenclature.
 - b. On the bottom of the slack adjuster you will see the lot number information. See Figure B.
 - c. If the combination of slack adjuster mold line and lot number exactly match any of the combinations in the table below, see Figure C, please contact the Gunite Slack Adjuster Help Line at 1-855-857-8645 between 7:00 a.m. and 4:00 p.m. Central time, Monday through Friday.

Side of Slack Adjuster Housing



Figure A: Mold Line Nomenclature

Bottom of Slack Adjuster Housing



Figure B: Lot Number



Gunite – Service Advisory

March 30, 2011

Lot Numbers and Corresponding Mold Line Nomenclature

<u>Lot Nos.</u>	<u>Mold Line</u>	<u>Lot Nos.</u>	<u>Mold Line</u>	<u>Lot Nos.</u>	<u>Mold Line</u>	<u>Lot Nos.</u>	<u>Mold Line</u>
0I06	1H	0K02	1H	1A15	1H	0K26	H
0I07	1H	0K04	1H	1A21	1H		
0I14	1H	0K10	1H	1A22	1H		
0I15	1H	0K12	1H				
0I17	1H	0K18	1H				
0I18	1H	0K22	1H				
0I19	1H	0K24	1H				
0I20	1H	0L12	1H				
0I26	1H	0L18	1H				
0J06	1H	0L22	1H				
0J07	1H	0L24	1H				
		0L28	1H				
		0L30	1H				

Figure C: Lot Numbers and Mold Line Nomenclature

All slack adjusters having the combined lot number and mold line number identified in the table in Figure C must be removed from inventory and returned to Gunite or removed from service disabled and scrapped with documentation. Please contact the Gunite Slack Adjuster Help Line at 1-855-857-8645 between 7:00 a.m. and 4:00 p.m. Central time, Monday through Friday for assistance with these instructions.

Visual Identification of Inspected and Certified Parts

Any Gunite slack adjuster that has passed inspection can be identified by either a green dot appearing on the box, see Figure D, or on the part, see Figure E and Figure F, and / or a capital letter "C" at the end of the run number, see Figure G. This will signify the housing has been certified okay to use.



Figure D



Figure E



Figure F



Figure G



Gunite – Service Advisory

March 30, 2011

Alternate Inspection for Slack Adjusters that are difficult to view mold line and lot number codes.

If you are inspecting slack adjusters on a vehicle and are not able to see the mold line and lot number, you can use the assembly date code on the end plate of the slack adjuster to determine if the slack adjuster could be in the suspect lot. If the code on the end plate is not contained on the list, no further inspection is necessary. If the code on the end plate is contained on the list the slack adjuster must be removed from the vehicle if necessary for further inspection to identify the mold line and lot number code on the housing. Some slack adjusters with the listed assembly code on the end plate will not have the mold line and lot number codes and can be used in service.

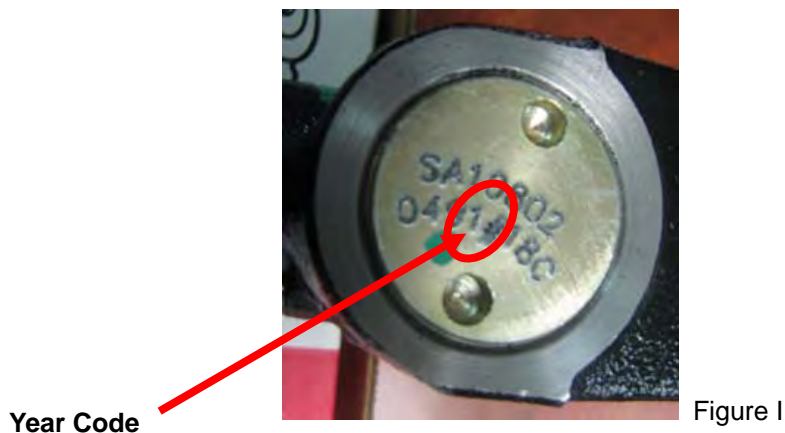
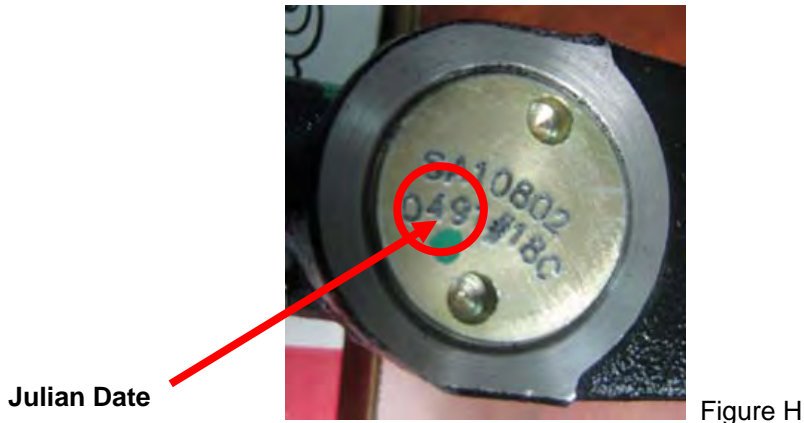

Assembly Date Codes on End Plate

<u>Julian date</u>	<u>Year code</u>
288 to 365	0
001 to 031	1

For example in the Figures H and I, the Julian date is 049 and the year code is 1. Therefore, this slack adjuster is not in the suspect lot.



Slack Adjuster Link Removal for rendering parts inoperative

Instead of returning used Slack Adjusters removed from vehicles to Gunite, the Slack Adjuster can be rendered inoperative by using the following procedure. Documentation (such as a picture) of the number of Slack Adjusters made inoperative is needed for reporting requirements.

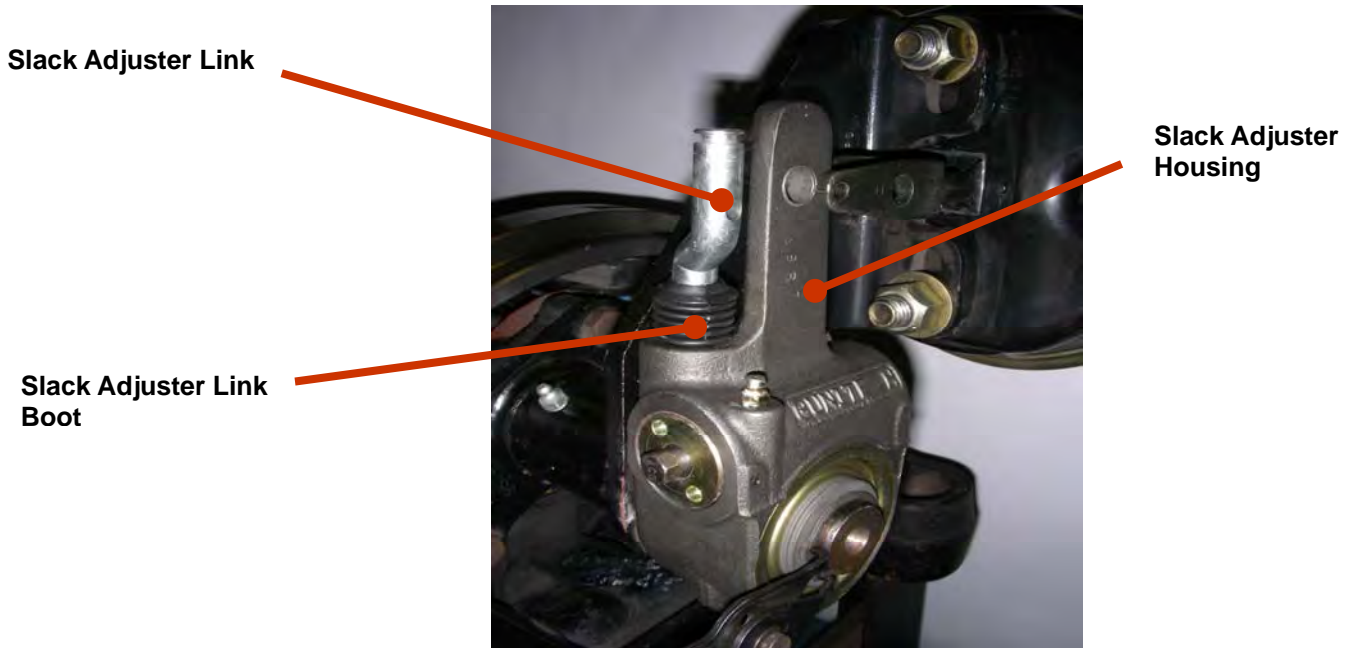

Step 1:
Using a 7/16 socket and wrench rotate adjusting hex head clockwise a minimum of a 1/4 turn allowing for the link to travel in a direction away from the slack adjuster housing. This allows the link to disengage the internal drive mechanism.

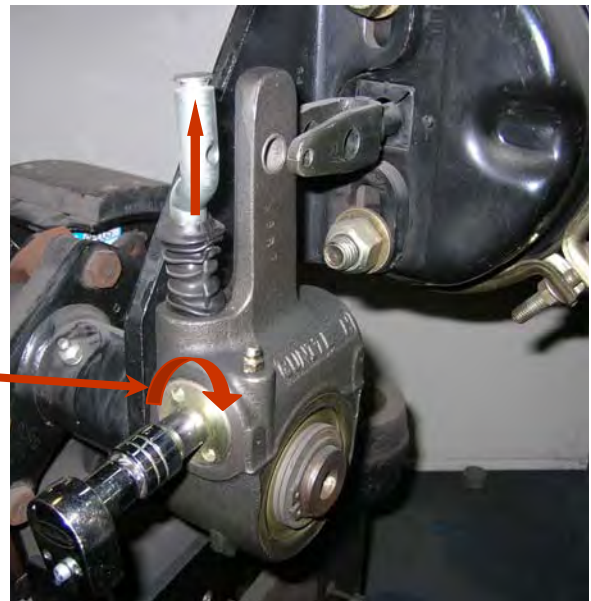

Step 2:
Using a little force pull
on the link away from the
slack adjuster housing
until it is removed from
the link boot.



Pulling Link

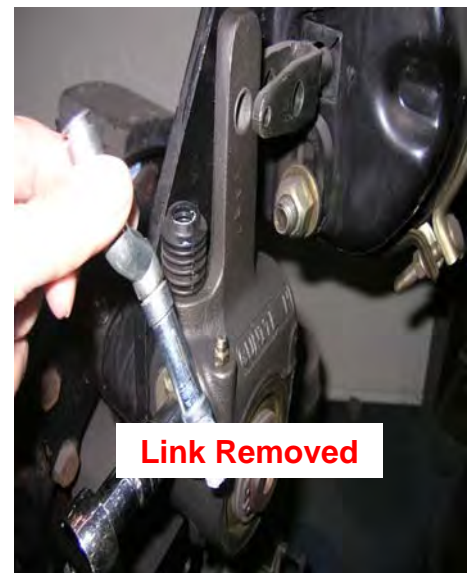

Link Removed

Step 3:

Email digital photos of disabled
slack(s) to:

slack2011@accuridecorp.com

For assistance call (855) 857-8645



Gunite Automatic Slack Adjusters

Service Manual



An ACCURIDE
COMPANY

Table of Contents

Overview	3
Clevis Descriptions	4
ASA Installation Preparation	4
ASA Installation Procedures by Clevis	5
Collar Lock Clevis	5
Threaded Clevis	7
Welded Clevis	9
Brake Adjustment	10
Power Stroke Inspection	10
Recommended Maintenance	11
Boot Replacement	12
Bushing Replacement	13
Cutting Push Rods	13
Brake Lining and/or Drum Replacement	14
Trouble Shooting	15

WARNING

AS WITH ALL PRODUCTS, CLOSE ATTENTION SHOULD BE GIVEN TO ALL INSTRUCTIONS INCORPORATED IN THIS MANUAL, IN PARTICULAR THE NOTES AND WARNINGS WHICH ARE HIGHLIGHTED. THIS MANUAL IS FOR GUNITE AUTOMATIC SLACK ADJUSTERS ONLY.

FAILURE TO STRICTLY FOLLOW THESE INSTRUCTIONS MAY RESULT IN THE UNIT PERFORMING IN AN UNSATISFACTORY MANNER AND RESULT IN INADEQUATE BRAKING ABILITY OR DRAGGING BRAKES. THESE CONDITIONS COULD MAKE OPERATION OF THE VEHICLE EXTREMELY HAZARDOUS.

ATTENTION

WHEN INSTALLING OR REPLACING A GUNITE AUTOMATIC SLACK ADJUSTER, A NEW CLEVIS MUST BE INSTALLED. REFER TO GUNITE PARTS CATALOG GUN1.0004 AND/OR ITS ADDENDUMS FOR CLEVIS SELECTION.

WARNING

GUNITE AUTOMATIC SLACK ADJUSTERS SHOULD NOT BE MANUALLY ADJUSTED IN AN EFFORT TO CORRECT EXCESSIVE PUSHROD STROKE. EXCESSIVE PUSHROD STROKE INDICATES THAT A PROBLEM EXISTS WITH THE GUNITE AUTOMATIC SLACK ADJUSTER, WITH THE INSTALLATION OF THE AUTOMATIC SLACK ADJUSTER, OR WITH THE RELATED FOUNDATION BRAKE COMPONENTS, WHICH MANUAL ADJUSTMENT WILL NOT FIX. MANUAL ADJUSTMENT OF GUNITE AUTOMATIC SLACK ADJUSTERS IS A DANGEROUS PRACTICE THAT COULD HAVE SERIOUS CONSEQUENCES, BECAUSE IT GIVES THE OPERATOR A FALSE SENSE OF SECURITY ABOUT THE EFFECTIVENESS OF BRAKES WHICH ARE LIKELY TO GO OUT OF ADJUSTMENT AGAIN SOON.

Overview

Gunite offers a complete line of unhanded automatic slack adjusters for installation on steer, drive, and trailer axles. The space required for the Gunite automatic slack adjuster is similar to that which is required for manual slack adjusters. Gunite automatic slack adjusters do not require any external brackets, adapters, or special mounting holes for installation.

Popular spline and arm length combinations allow them to be used to replace most other slack adjusters. However, brands should not be mixed on the same axle.

THE BRAKES SHOULD BE IN GOOD OPERATING CONDITION AND STATE OF REPAIR WHEN GUNITE AUTOMATIC SLACK ADJUSTERS ARE INSTALLED. NO SLACK ADJUSTER CAN COMPENSATE FOR PROBLEMS AND DEFICIENCIES IN THE FOUNDATION BRAKING SYSTEM.

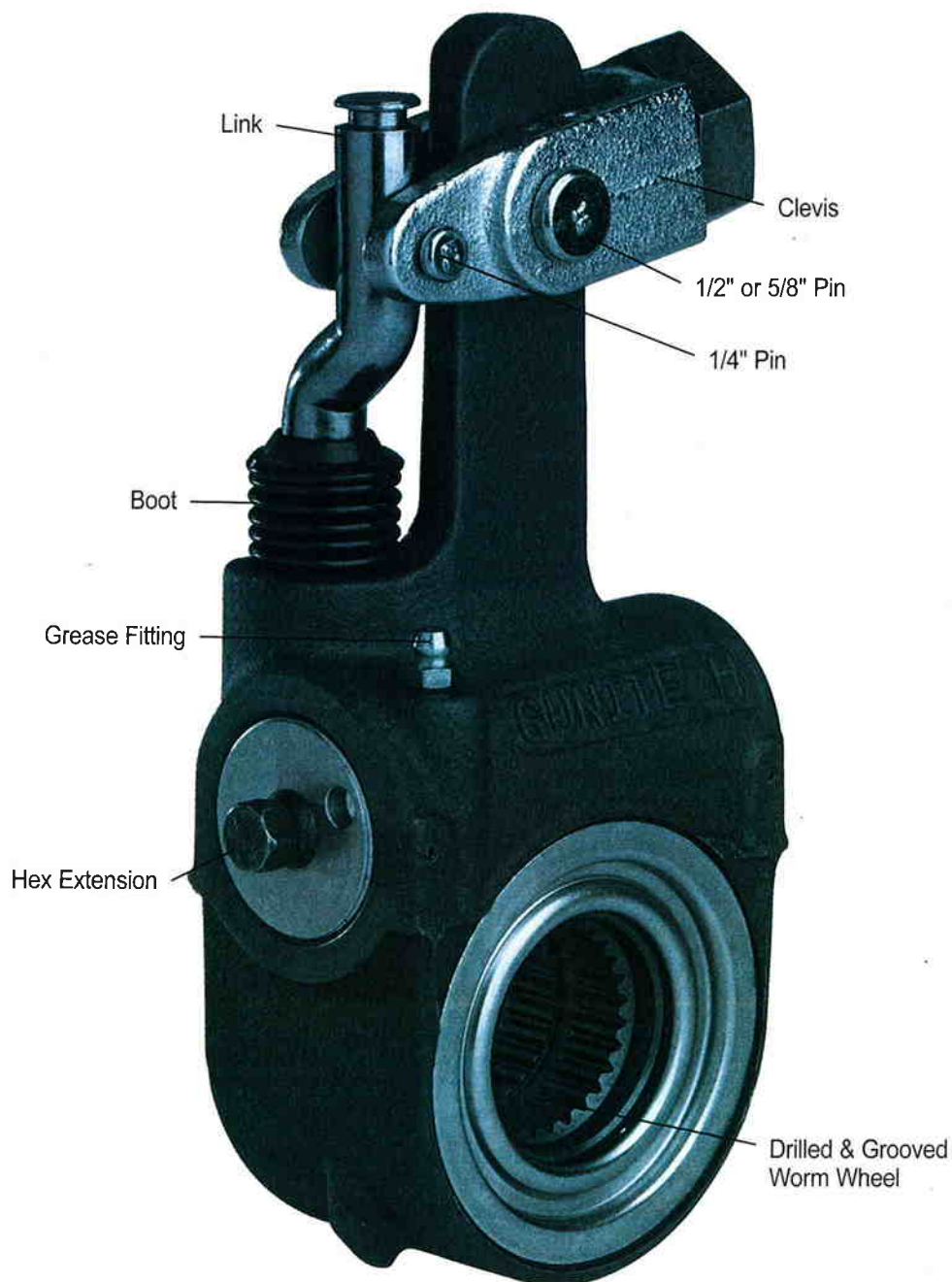
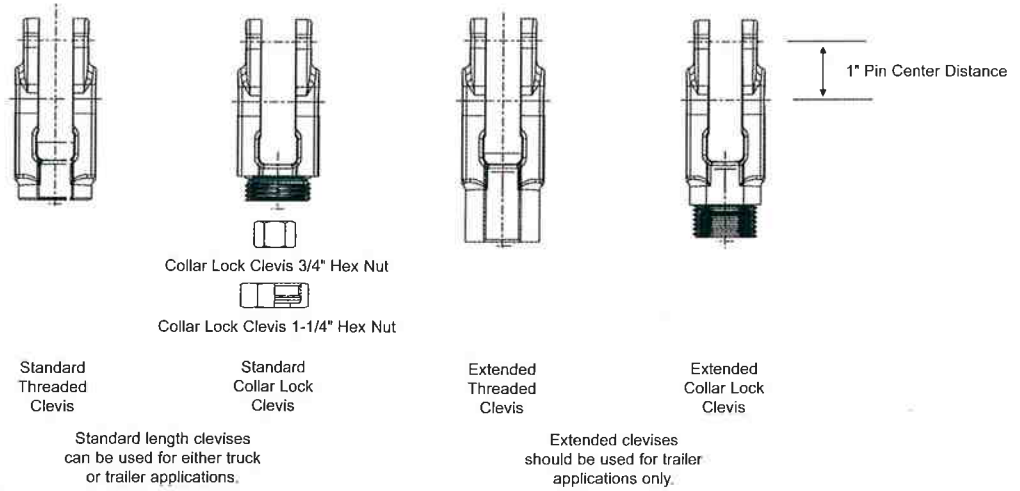

Figure 1 – Gunite Automatic Slack Adjuster

Clevis Descriptions

1" Pin Center Distance Clevises (Use with Traditional 1" Pin Distance ASA, Installation Gauge SD04603)



1.3" Pin Center Distance Clevises (Use with Gunite 2000 ASA, Installation Gauge SD04604)

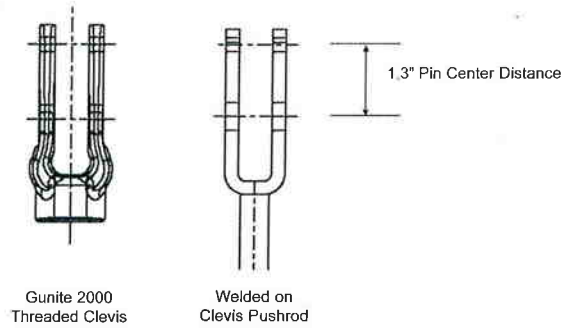
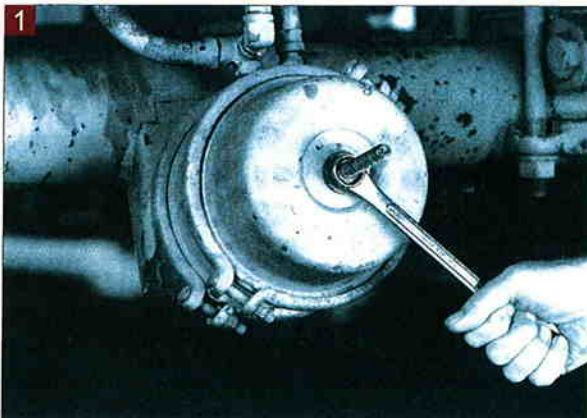

Figure 2 – Clevis Types

ASA Installation Preparation



1 Block the vehicle's wheels. If the axle is equipped with spring brakes, manually cage the brakes following the manufacturer's recommended procedures.

Check the operating condition of the foundation brakes, including drums, shoe and lining, cams, bushings, rollers, etc. Replace or repair as necessary.



2 Remove the existing clevis and Gunite automatic slack adjuster. Keep the existing mounting hardware. Do not remove the clevis jam nut.

Refer to Figure 2 and determine if your Gunite automatic slack adjusters are equipped with the threaded clevis, welded clevis, or the collar lock clevis (extended or standard length). Refer to the correct installation procedure for the style of clevis used on your Gunite automatic slack adjusters.

ASA Installation Procedures by Clevis

Collar Lock Clevis ASA Installation Procedure



Apply anti-seize to the chamber push rod threads before installing the new clevis. Also apply anti-seize to the camshaft at this time.



When installing a Gunite automatic slack adjuster with a collar lock clevis, place the 1-1/4" collar nut on the push rod against the 15/16" jam nut. Next thread the 3/4" hex nut onto the push rod.



Install the slack onto the camshaft using the original mounting hardware.

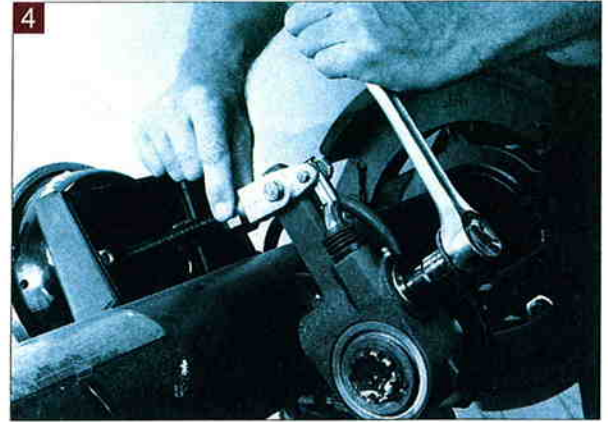

Using the hex extension and a wrench, adjust the Gunite automatic slack adjuster so that the collar nut aligns with the threaded area of the clevis. **Do not use an air impact wrench on the 7/16" hex. It can damage the clutch.**

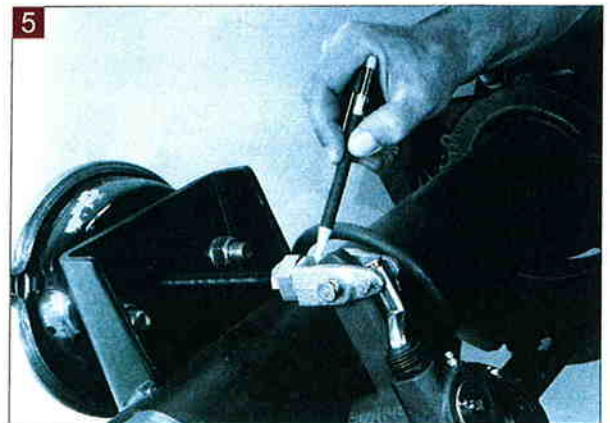

Before attaching the 1-1/4" collar nut to the clevis, check to make sure the threaded push rod is fully engaged in the 3/4" hex nut. If the push rod does not have full engagement, a new push rod must be installed and cut to length. Refer to the section on cutting a new push rod to length in this service manual.

The push rod may extend up to 1/16" past the clevis opening. If the push rod extends more than 1/16" past the clevis opening, mark the push rod and remove the clevis to allow the push rod to be cut to the proper length.

Gunite automatic slack adjusters using the collar lock clevis are available with either standard or extended clevis designs depending on the application. On trailer applications, an extended clevis can be used instead of replacing the push rod. However, you must still have full thread engagement inside the hex nut. If you have less than full thread engagement, a new push rod must be installed. If you replace the push rod, you must cut the new push rod to the proper length. Refer to the section on cutting a new push rod to length in this service manual. **Do not use an extended clevis on tractor applications, the extended clevis may interfere with the face of the air chamber.**

NOTE

On axles equipped with spring brake chambers, be sure the chambers are fully caged before cutting the push rod. If the spring brakes are not fully caged, the push rod can be cut too short.



After threading the 1-1/4" collar nut onto the clevis housing, place the template over the large and small clevis pins as shown above.

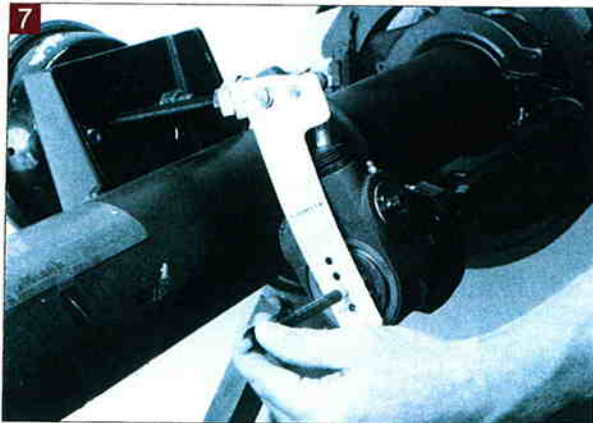

Align the Gunite automatic slack adjuster by adjusting the 3/4" hex nut on the push rod until the appropriate centering hole on the template aligns with the center hole on the cam-shaft. The template is provided with centering holes for 5, 5.5, 6, and 6.5 inch arm lengths. Refer to page 4 for proper gauge.

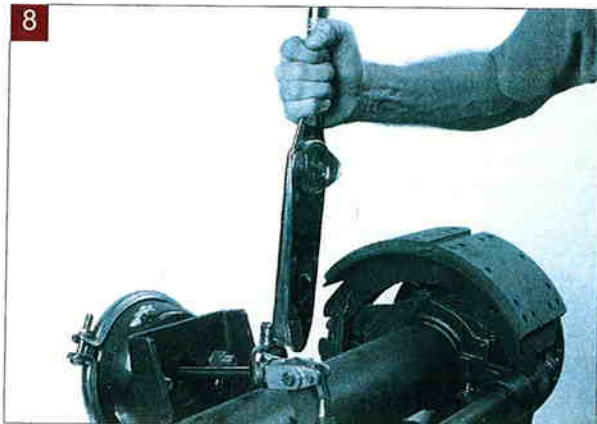

Using a torque wrench, tighten the 1-1/4" collar nut to the clevis using 40 to 50 ft. lbs. of torque.

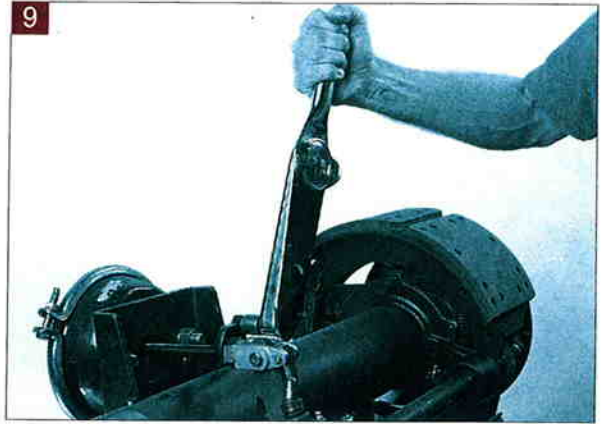

Once the 1-1/4" collar nut has been properly tightened to the clevis, tighten the 15/16" jam nut against the collar lock nut using 40 to 50 ft. lbs. of torque.

NOTE

Failure to tighten the jam nut will allow the air chamber push rod to rotate in the clevis and change the installed position of the Gunite automatic slack adjuster, preventing proper automatic slack adjuster function.



Fully apply the brakes and allow the chamber push rod to travel its maximum stroke. Clearance must exist between the Gunite automatic slack adjuster and all adjacent chassis components. Release the brakes.

After completing this step, refer to page 10 for Proper Brake Adjustment and Power Stroke Inspection.

Threaded Clevis ASA Installation Procedure

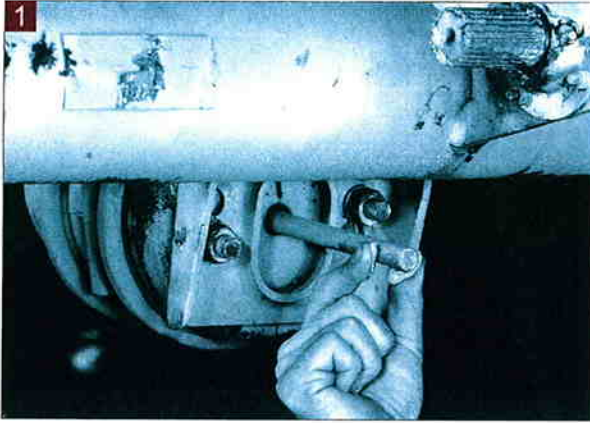

Apply anti-seize to the chamber push rod threads before installing the new clevis.

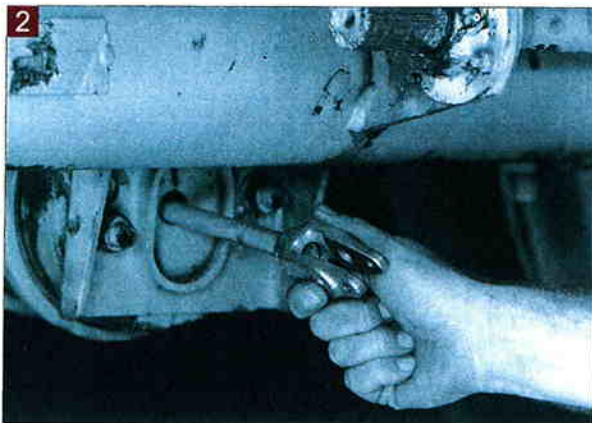

When installing a Gunitite automatic slack adjuster with a threaded clevis, install the new clevis on the push rod in the same location as the clevis which was removed. Do not tighten the jam nut at this time.



Once the clevis has been installed on the threaded push rod, install both the large and small clevis pins. Now position the installation template over both the large and small clevis pins. Refer to page 4 for proper gauge.



Align the clevis on the threaded push rod until the appropriate centering hole on the template aligns with the center hole on the camshaft. The template is provided with centering holes for 5, 5.5, 6, and 6.5 inch arm lengths.

Once the clevis has been properly adjusted, remove the template and the two clevis pins.

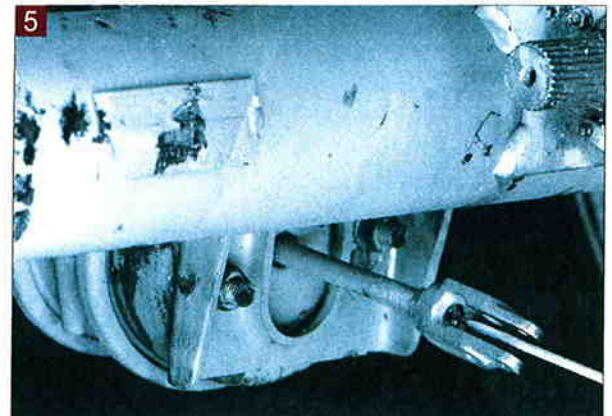

Inspect the clevis installation to make sure that the threaded push rod extends no more than 1/16" past the end of the opening of the clevis in the clevis housing. If the push rod extends more than 1/16" past the clevis housing, the clevis must be removed and the push rod cut to the proper length.

It is also important to make sure that the push rod is not too short for proper installation. To do this, check to make sure that the push rod is not more than 1/8" short of being flush with the clevis opening on a standard clevis (5/8" on an extended clevis). If the threaded push rod is more than 1/8" from being flush with the clevis opening on a standard clevis (5/8" on an extended clevis) it must be removed, a new push rod must be installed and cut to the proper length.

Follow instructions in this service manual for cutting a push rod to length.

NOTE

On axles equipped with spring brake chambers, be sure the chambers are fully caged before cutting the push rod. If the spring brakes are not fully caged, the push rod can be cut too short.



Tighten the jam nut against the clevis housing using 40 to 50 ft. lbs. of torque. If you do not tighten the jam nut now, it will allow the clevis to rotate freely and change the position of the clevis resulting in an improper installation.

NOTE

Failure to tighten the jam nut will allow the air chamber push rod to rotate in the clevis and change the installed position of the slack, preventing proper automatic slack adjuster function.

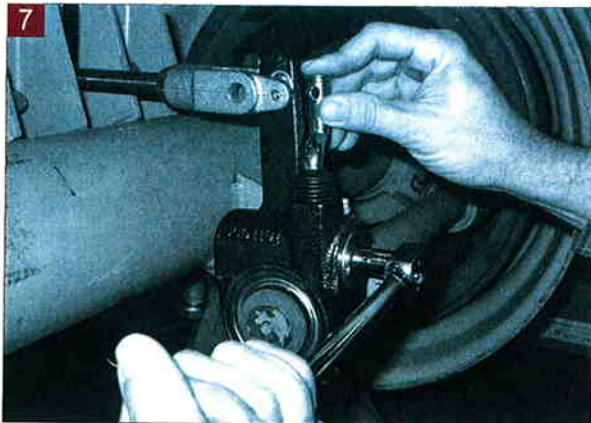

Apply anti-seize compound to the camshaft and install the automatic slack adjuster using the original mounting hardware. Use the hex extension to align the automatic slack adjuster with the clevis pin holes. Hold the link down while rotating the hex extension clockwise. Failure to do so can cause the link to disengage from the drive. Do not use an air impact wrench on the 7/16" hex. It can damage the clutch.



Once the clevis is properly aligned with the Gunitite automatic slack adjuster, insert both the large and small clevis pins and secure with the cotter pins supplied.

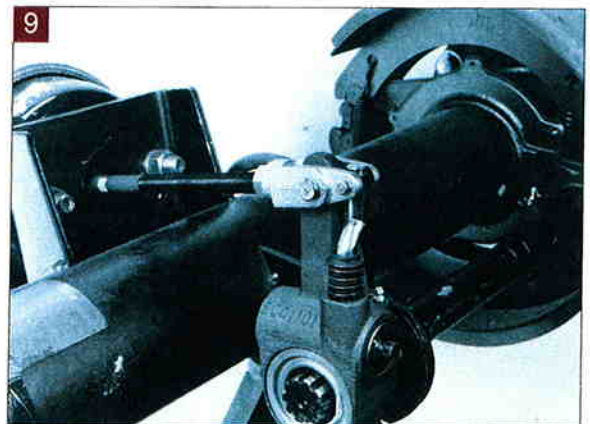

Fully apply the brakes and allow the chamber push rod to travel its maximum stroke. Clearance must exist between the Gunitite automatic slack adjuster and all adjacent chassis components. Release the brakes.

After completing this step, refer to page 10 for Proper Brake Adjustment and Power Stroke Inspection.

Welded Clevis ASA Installation Procedure

NOTE:

THESE INSTALLATION INSTRUCTIONS ARE FOR AIR CHAMBERS WITH A WELDED ON CLEVIS. WELDED ON CLEVISES HAVE A 1.3" PIN CENTER DISTANCE.



Apply anti-seize compound to the camshaft and install the automatic slack adjuster using the original mounting hardware. Properly shim the automatic slack adjuster by placing one of the existing washers onto the camshaft. Next install the automatic slack adjuster onto the camshaft and place the second washer on the end of the camshaft, on the outside of the clip. Re-attach the retaining clip.



Using a 7/16" wrench or a socket, rotate the hex extension clockwise until the holes in the Gunite automatic slack adjuster are properly aligned with the corresponding holes in the welded clevis. Hold the link down while rotating the hex extension clockwise. Failure to do so can cause the link to disengage from the drive. Do not use an air impact wrench on the 7/16" hex. It can damage the clutch.

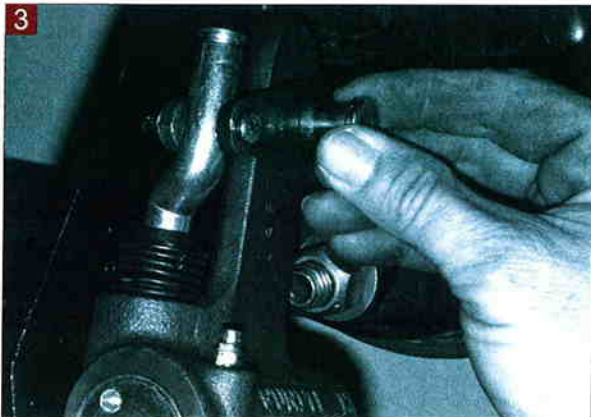

Insert the large and small pins in the proper clevis holes.



Insert the cotter pins into the large and small pin holes and secure the cotter pins.

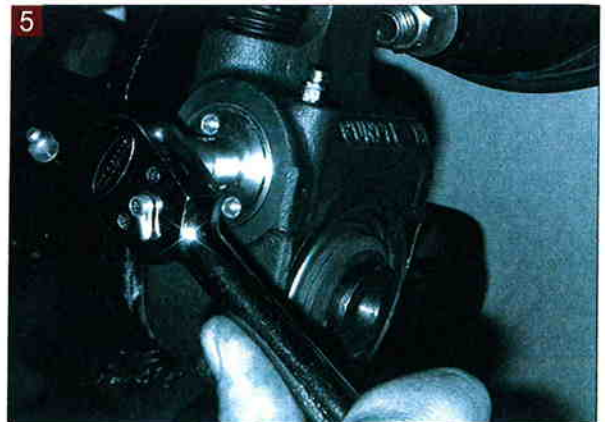

Fully apply the brakes and allow the chamber push rod to travel its maximum stroke. Clearance must exist between the Gunite automatic slack adjuster and all adjacent chassis components. Release the brakes.

NOTE

When installing the Gunite 2000 slack adjuster with a welded on clevis air chamber, it is not necessary to use an installation gauge. The proper mounting angle has been designed into the product.

After completing this step, refer to page 10 for Proper Brake Adjustment and Power Stroke Inspection.

Brake Adjustment

Follow this Procedure to Properly Adjust the Brakes:



Using a 7/16" wrench or socket, rotate the hex extension **clockwise** until the brake linings make contact with the braking surface of the drum. Do not use an air impact wrench on the 7/16" hex. It can damage the clutch.



Using a 7/16" wrench or socket, back off the Gunite automatic slack adjuster by rotating the hex extension **counterclockwise** 1/2 turn. This will require 15 to 50 ft. lbs. of torque. When backing off the slack, a ratcheting sound will be heard.

WARNING

GUNITE AUTOMATIC SLACK ADJUSTERS SHOULD NOT BE MANUALLY ADJUSTED IN AN EFFORT TO CORRECT EXCESSIVE PUSHROD STROKE. EXCESSIVE PUSHROD STROKE INDICATES THAT A PROBLEM EXISTS WITH THE GUNITE AUTOMATIC SLACK ADJUSTER, WITH THE INSTALLATION OF THE AUTOMATIC SLACK ADJUSTER, OR WITH THE RELATED FOUNDATION BRAKE COMPONENTS, WHICH MANUAL ADJUSTMENT WILL NOT FIX. MANUAL ADJUSTMENT OF GUNITE AUTOMATIC SLACK ADJUSTERS IS A DANGEROUS PRACTICE THAT COULD HAVE SERIOUS CONSEQUENCES BECAUSE IT GIVES THE OPERATOR A FALSE SENSE OF SECURITY ABOUT THE EFFECTIVENESS OF BRAKES WHICH ARE LIKELY TO GO OUT OF ADJUSTMENT AGAIN SOON.

Power Stroke Inspection

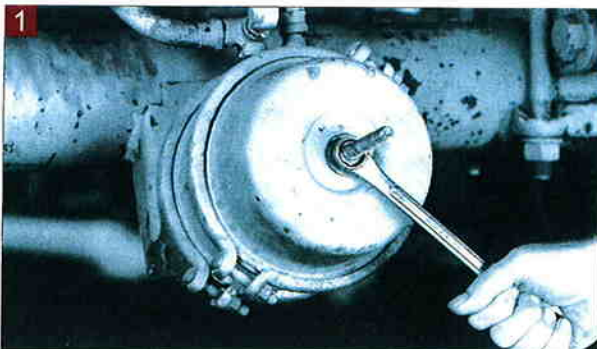

Block the wheels and uncage the spring brakes.

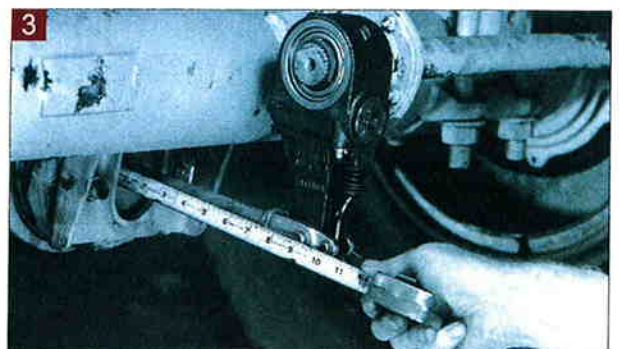

Make an 85-psi brake application and allow the air chamber to travel its maximum stroke. Measure the distance between the face of the air chamber and the center of the large clevis pin (B) (see Figure. 3). The difference between the (A) measurement and the (B) measurement is the push rod stroke. Check the charts located on page 11 for the proper maximum stroke after adjustment of the brakes.



Using a ruler, measure the distance from the face of the air chamber to the center of the large pin in the clevis (A). (see Figure. 3)

“STANDARD” CLAMP TYPE BRAKE CHAMBER DATA

Type	Outside Diameter	Rated Stroke	Maximum Legal Stroke Limit
9	5-1/4	1.75	1-3/8
12	5-11/16	1.75	1-3/8
16	6-3/8	2.25	1-3/4
20	6-25/32	2.25	1-3/4
24	7-7/32	2.25	1-3/4
30	8-3/32	2.50	2
36*	9	3.00	2-1/4

*Note: If type 36 chamber is used, slack length should be less than 6".

“LONG STROKE” CLAMP TYPE BRAKE CHAMBER DATA

Type	Outside Diameter	Rated Stroke	Maximum Legal Stroke Limit
16	6-3/8	2.50	2
20	6-25/32	2.50	2
24	7-7/32	2.50	2
24*	7-7/32	3.00	2-1/2
30*	8-3/32	3.00	2-1/2

* Note: Identified by square air port bosses.

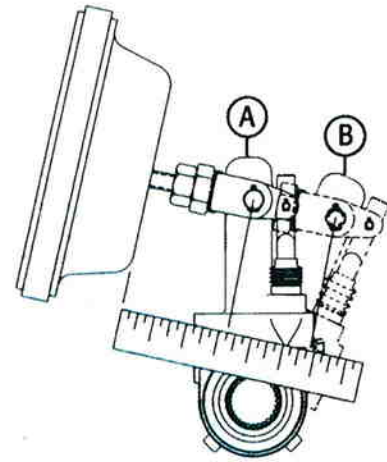

Figure 3 – Measuring Maximum Stroke

Recommended Maintenance

Every Three Months or 25,000 Miles

1. Check the condition of the foundation brakes, including drums, shoes and linings, cams, rollers, bushings, etc.
2. Check for structural damage of the housing, worn clevis, worn clevis bushings, and condition of the boot for cuts or tears. Replace if necessary.
3. After allowing the brake drum to cool to room temperature, check for correct chamber stroke following the procedure on page 10. Due to different operating

conditions, chamber stroke tests may be necessary at earlier intervals. See Charts on page 11 for the recommended stroke measurements.

NOTE

A Gunite automatic slack adjuster should not have to be manually adjusted except for initial installation and at the time of brake reline.

Every Six Months or 50,000 Miles Grease the Slack Adjuster

Gunite automatic slack adjusters are factory lubricated and extensively sealed to protect against dirt, water, salt, and other corrosive elements. Nevertheless, periodic lubrication is recommended.

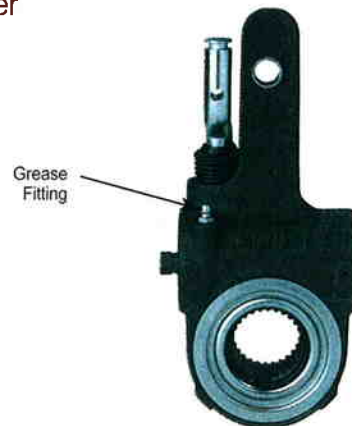

Figure 4 – Lubrication Points

1. A grease fitting is provided to allow lubrication during normal chassis servicing. (see Figure 4) With a conventional grease gun, lubricate until grease appears on the camshaft.

NOTE

Lubrication should be performed using an NLGI 1 or 2 grade grease that has a working range of -40 degrees F to 250 degrees F. A grease containing Molybdenum Disulfide should not be used as it will likely have a negative impact on the function of key friction components and reduce the operational efficiency of the automatic slack adjuster.

Service Practices: Points and Precautions

1. Replace the Gunite automatic slack adjuster if it is not functioning properly, as described under Function Test on page 15.
2. Replace the entire unit if damage is evident on the slack housing or assembly.
3. The unit must be replaced **if less than 15 ft. lbs.** of torque exists when turning the hex extension counterclockwise. Refer to the test as described under Trouble Shooting on page 15.
4. Never operate the vehicle with small 1/4" pin missing from the clevis. The Gunite automatic slack adjuster will not maintain proper brake adjustment with either pin missing. (see Figure 6)
5. Never attempt to disassemble a Gunite automatic slack adjuster. Factory setting cannot be duplicated in the field. Instead, replace the entire unit.

Boot Replacement

Boot Replacement - 4 Bellows Only

1. Remove the 1/4" and the large clevis pins.
2. Rotate the hex extension counterclockwise to clear the link from the clevis. This could require up to 50 ft. lbs. of torque and produce a ratcheting sound.
3. Remove the damaged boot from the link. (see Figure 7)
4. Install the replacement boot over the link with the heavy section down. Care should be taken not to damage the boot with a sharp tool.
5. Position the boot on the link so that the bottom is retained by the boot insert and the top is positioned by the groove in the link.
6. Install the clevis pins.
7. Gunite automatic slack adjusters equipped with the 6 bellows TRU-SEAL boot are not field serviceable. In the event of a torn boot, the Gunite automatic slack adjuster must be replaced. (see Figure 8)

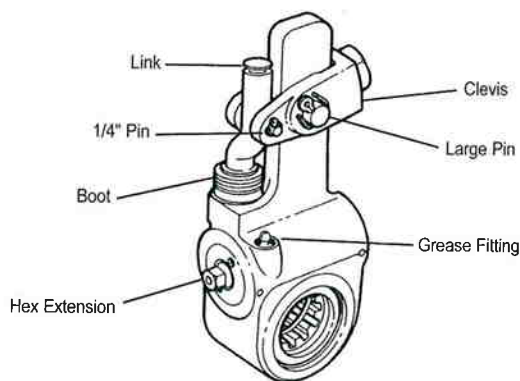

Figure 6 – Location of Clevis Pins, Hex Extension & Boot

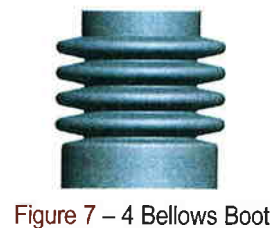

Figure 7 – 4 Bellows Boot



Figure 8 – 6 Bellows TRU-SEAL Boot

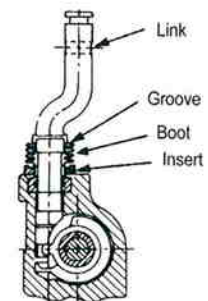
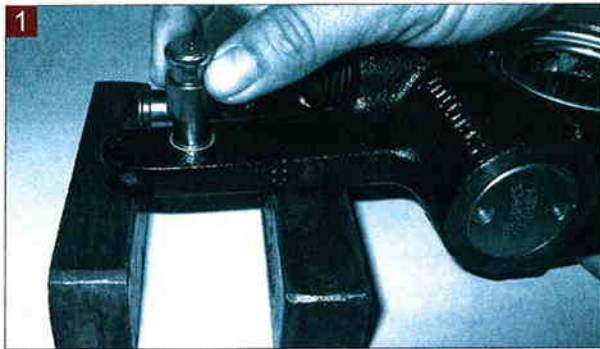
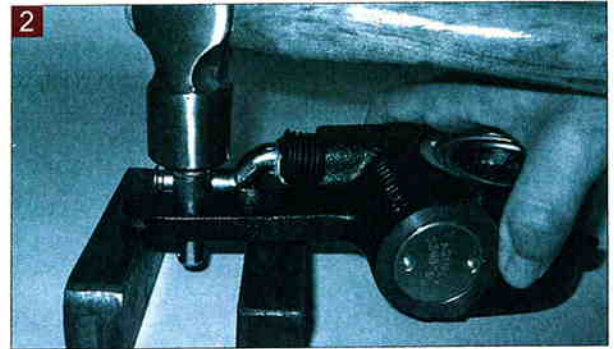

Figure 9 – Boot Position

Bushing Replacement



1 Insert clevis pin into a new bushing. Support arm of Gunite automatic slack adjuster and insert clevis pin with new bushing into old bushing.



2 Using a hammer, drive the new bushing into the arm of the automatic slack adjuster while driving out the old bushing. Make sure the new bushing is flush with the sides of the arm.

Cutting Push Rods

This Procedure is for Collar Lock and Threaded Clevis Applications Only

1. Install the brake chamber in the proper mounting holes of the chamber bracket for the Gunite automatic slack adjuster length required.
2. If the axle is equipped with spring brake chamber, manually cage the spring brakes following the manufacturer's recommended procedures. The chamber must be in the fully released position.
3. Using a square, mark the universal push rod at the 90 degree position when the square edge is centered in the end of the S-Cam. (see Figure 10) Make sure the push rod is centered in the chamber and not cocked before marking the push rod.
4. From the 90 degree mark, measure back toward the air chamber the proper "X" distance from the following chart. Mark the push rod at the "X" dimension. Cut the push rod at this mark. (see Figure 11) The clevis is now ready to install on the push rod.

Slack Adjuster Arm Length	"X" Dimension	
	Gunite Standard Clevis	Gunite 2000 Clevis
5" – 5-1/2"	2-1/4"	2-1/2"
6" – 6-1/2"	2-1/2"	2-3/4"

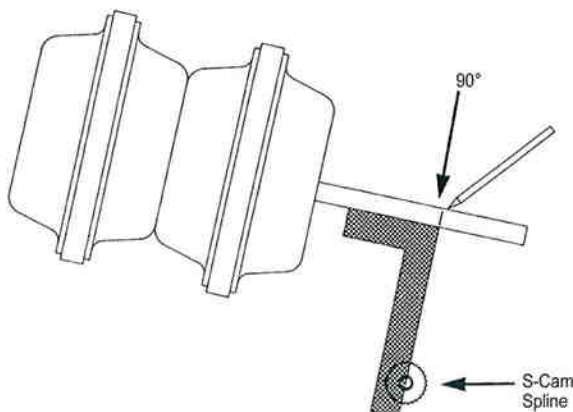

Figure 10 – Marking the Push Rod

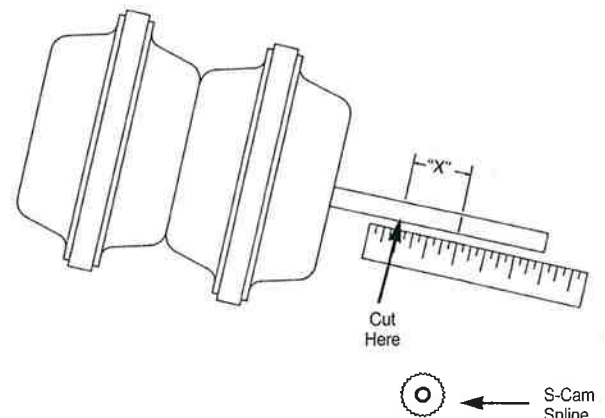
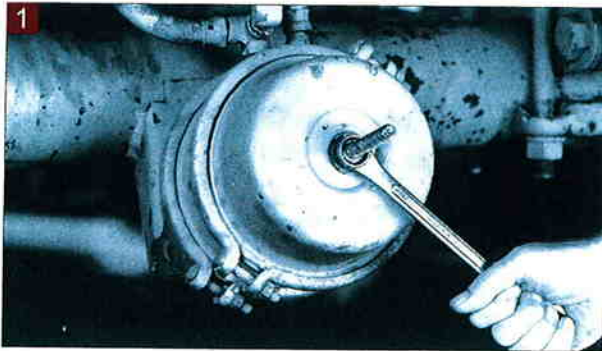

Figure 11 – Cutting the Push Rod

Brake Lining and/or Drum Replacement

Special attention must be given to following proper maintenance procedures when changing linings and/or drums on a vehicle equipped with Gunite automatic slack adjusters. Following these procedures will ensure that the automatic slack adjuster is functioning correctly before returning the vehicle to service.

Block the vehicle's wheels.



If the vehicle is equipped with spring brake chambers, manually cage the spring brakes following the manufacturer's recommended procedures.

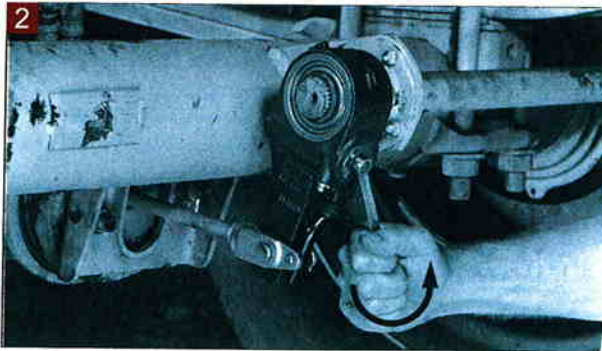

Using a 7/16" wrench or socket, rotate the hex extension counterclockwise. You should have at least 15 ft. lbs. resistance and a ratcheting sound will be heard as the hex extension is rotated. Do not use an air impact wrench on the 7/16" hex. It can damage the clutch.

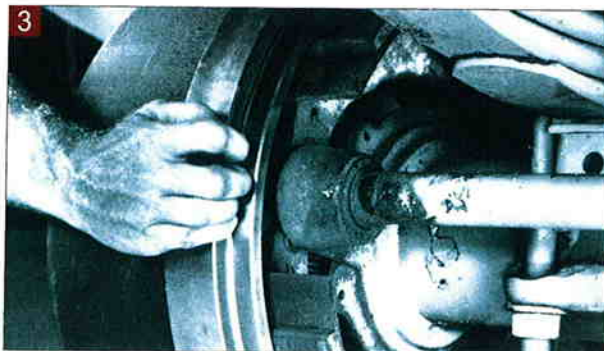

Only back off the adjusting hex enough to allow the drum to clear the lining. Remove the brake drum.

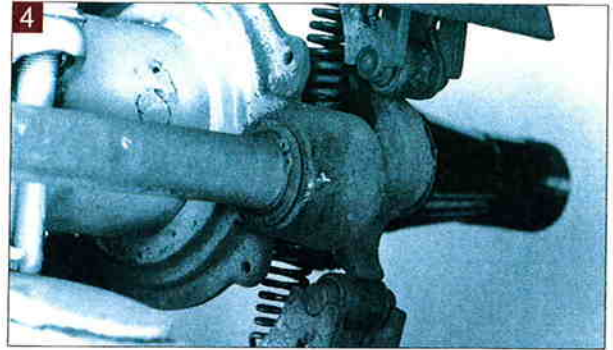

After the brake drum has been removed; rotate the hex extension clockwise until the cam turns over. This will allow the brake rollers to be in the release position.



Proceed with the lining change and/or brake drum replacement.

After completing this step, refer to page 10 for proper brake adjustment, uncage the spring brakes, and refer to page 10 for Power Stroke inspection.

Trouble Shooting

1. Gunite automatic slack adjusters should not have to be manually adjusted except for initial installation and at the time of brake reline.

If the **power stroke**, with an 85-psi brake application is less than the maximum legal stroke limit shown in the chart on page 11, the Gunite automatic slack adjuster is functioning properly.

2. If the chamber stroke exceeds the Maximum Legal Stroke Limit, measure the free stroke.
3. **Free stroke** is the amount of movement of the slack adjuster arm required to move the brake shoes against the drum. With the brakes released, measure from the face of the air chamber to the center of the large clevis pin. (see figure 12)

Apply pressure using a lever to activate the Gunite automatic slack adjuster until the brake shoes make contact with the brake drum surface. The difference between the released and the applied measurements is the free stroke. The free stroke should be $3/8"$ to $5/8"$.

If the free stroke is less than $3/8"$, a dragging brake can occur. If this situation occurs repeat the manual adjustment by repeating steps 1 through 3 under Brake Adjustment.

If the free stroke is greater than the recommended distance of $5/8"$, a function test of the Gunite automatic slack adjuster should be performed.

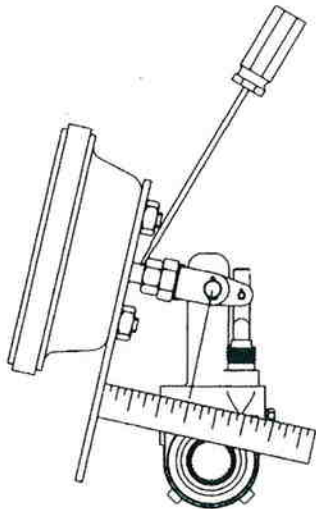

Figure 12 – Free Stroke

4. To perform a **function test**, place a $7/16"$ box wrench on the hex extension and rotate it $3/4$ of a turn counterclockwise. A ratcheting sound will be heard. Mark the $7/16$ hex extension with chalk and apply the brakes several times and watch for the hex to rotate clockwise.

The hex extension must rotate clockwise. The adjustment is intentionally made in small increments so it will take several cycles to bring the adjuster within the **Maximum Legal Stroke Limit** in the chart.

If the **power stroke** is greater than the **Maximum Legal Stroke Limit**, the **free stroke** is greater than $5/8"$ and the function test shows that the adjusting mechanism is working check the clevis pins, clevis pin holes, and **arm** bushing for wear. Replacing clevises, pins, and bushings that show wear may bring the brake within the legal stroke limit.

5. Check the **clockwise and counterclockwise torque** by attaching a torque wrench to the hex extension and turning in the clockwise and counterclockwise directions and record the measurement. The clockwise torque specification is 10 ft. lbs. maximum. The counterclockwise torque specification is 15 to 50 ft. lbs. If these torque specifications are violated the Gunite automatic slack adjuster must be replaced.
6. If the Gunite automatic slack adjuster passes the **free stroke, function test, clockwise and counterclockwise torque** tests and the brake does not meet the **Maximum Legal Stroke Limit** check the foundation brake. Check for worn cam bushings, pins, rollers, broken springs, broken drums, sprung linings, worn quick connect clevises, clevis pins, and clevis bushings. Repair as necessary and repeat the **function test** to see if the Gunite automatic slack adjuster meets the **Maximum Legal Stroke Limit**.
7. Pins seizing are a result of corrosive environments. If pins seizing are a problem, they should be replaced with stainless steel pins.

WARNING

GUNITE AUTOMATIC SLACK ADJUSTERS SHOULD NOT BE MANUALLY ADJUSTED IN AN EFFORT TO CORRECT EXCESSIVE PUSHROD STROKE. EXCESSIVE PUSHROD STROKE INDICATES THAT A PROBLEM EXISTS WITH THE AUTOMATIC SLACK ADJUSTER, WITH THE INSTALLATION OF THE AUTOMATIC SLACK ADJUSTER, OR WITH THE RELATED FOUNDATION BRAKE COMPONENTS, WHICH MANUAL ADJUSTMENT WILL NOT FIX. MANUAL ADJUSTMENT OF GUNITE AUTOMATIC SLACK ADJUSTERS IS A DANGEROUS PRACTICE THAT COULD HAVE SERIOUS CONSEQUENCES BECAUSE IT GIVES THE OPERATOR A FALSE SENSE OF SECURITY ABOUT THE EFFECTIVENESS OF BRAKES WHICH ARE LIKELY TO GO OUT OF ADJUSTMENT AGAIN SOON.

If you need additional service manuals or installation gauges, contact Gunite Corporation at the address listed on the back of this manual.



Gunite
302 Peoples Avenue
Rockford, IL 61104-7092
Phone: 815.964.3301
Toll-Free: 800.677.3786
Fax: 815.964.0775
www.gunite.com

ACCURIDE CORPORATION

Accuride Corporation
7140 Office Circle
P.O. Box 15600
Evansville, IN 47716
Phone: 812.962.5000
Toll-Free: 800.823.8332
Fax: 812.962.5400
www accuridecorp.com

Distributed By:

