

FMI-11-005
 Contract:
 Classification: NC-4
 No. of Buses: 1,095

Date: 04/27/11
 REV: NR
 MRN: 01013-8
 Written by: G. Plavnik/J. Pearson

A. SUBJECT:

Replacement of cam in P/N 50530211-02 and 50530211-04 Teeter Lever Assemblies

B. REFERENCES

NHTSA Equipment Recall 11E-010, Vapor Bus International
 NHTSA Vehicle Recall 11V-214, Daimler Buses North America
 NHTSA Vehicle Recall 11V-237, New Flyer Industries

C. RELATED DOCUMENTS:

Drawing 50530211

D. MODIFIED ASSEMBLIES:

P/N	Dwg. #	Description	Qty/Bus Set	Total Quantity
50530211-02	50530211	Teeter Lever, Assembly	1	
50530211-04	50530211	Teeter Lever, Assembly	1	

E. PARTS REQUIRED:

P/N	Dwg. #	Description	Qty per Bus	Remarks
6711104541	67111045	Screw Flat Head Hex Socket Alloy Steel, #10-32 x.75" Long	3	
6711000726	67110007	"Loctite" #262	AR	
50726261	D50726261	Cam assembly (marked "A")	1 of	For 50530211-04
50726261-01	D50726261	Cam assembly (marked "B")	one of	For 50530211-04
50726261-02	D50726261	Cam assembly (marked "C")	these	For 50530211-02
50726261-03	D50726261	Cam assembly (marked "D")	parts	For 50530211-02
50526087-00	D50526087	Teeter Lever and Cam Assy.	AR	Replaces 50530211-02
50526087-01	D50526087	Teeter Lever and Cam Assy. with Resilient Lock	AR	Replaces 50530211-04

F. DRAWINGS REQUIRED: None

- G. **MATERIAL DISPOSITION:** Removed cams and teeter-lever assemblies should be scrapped. **DO NOT** retain or reuse.
- H. **SPECIAL TOOLS:** 1/8" Allen wrench
- I. **MODIFICATION INSTRUCTIONS:**
1. Remove air pressure from the door operator by turning off the air supply to the door system.
 2. Turn off electrical power to the door system.
 3. Determine whether or not the teeter lever assembly (Fig. 1 and 2) is a welded assembly (Fig. 3) by looking for the cam mounting screws (Item 5 in Fig 2). If the cam mounting screws are present, the teeter lever assembly is mechanically fastened. If there are no cam mounting screws, the teeter lever assembly is a welded assembly. If the teeter lever assembly is a welded assembly, it should be left as is and no further work is required. Mark the vehicle remediation record to indicate that it is a welded assembly and proceed to the next vehicle. If the teeter lever assembly is a mechanically fastened assembly, proceed to Step 4.
 4. Identify the teeter lever assembly as either a P/N 50530211-02 (Fig.4) or 50530211-04 (Fig. 5)
 5. Remove retaining ring 1 and lift up emergency release cam 2 (Fig.1) to provide access to the teeter lever screws 5 (Fig.2).
 6. Remove screws 5 (Fig.2), attaching cam 3 to the teeter lever base 4 and remove cam 3.
 7. Check for damaged or broken off cam mounting screws (Fig. 6). If one or more of the cam mounting screws has broken off in the base, or if one or more of the tapped holes in the base has been damaged, **the complete teeter lever assembly must be replaced**. If there are no broken screws and there is no damage to the tapped holes in the base, proceed to Step 8.
 8. Check the flat surfaces of the cam 6 and the leading surfaces 9 of the teeter lever base 4 (Fig. 7) for deformation (see examples of deformation in Fig. 8).
 9. If there is any deformation at the leading surfaces 6 of the cam 3 or at the flat driving surfaces 9 of the base 4, **the complete teeter lever assembly must be replaced**. If there is no deformation to these surfaces, proceed to Step.10.
 10. Determine which cam ("A" or "B" for assembly 50530211-04; and "C or "D" for assembly 50530211-02 respectively) should be used for modification of the teeter

lever assembly. The design dimensions of cams “A & C” and cams “B & D” are identical. The difference between the groups of cams “A & B” and “C & D” is that cams “A” and “B” have a welded pin for installation of the resilient lock cam. The procedure for installation of cams A/B and C/D is identical.

- Cams P/N 50726261, 50626261-01 (marked as “A” and “B” in Figure 9.) should be used for assembly of teeter lever P/N 50530211-04 (with resilient lock).
- Cams 50626261-03 & -04 (marked as “C” & “D” in Figure 10.) should be used for assembly of teeter lever P/N 50530211-02 (without resilient lock).

10.1 As shown in Figure 11, hand fit the appropriate “A” or “C” cam to the teeter lever base 4. Determine whether or not the “A” or “C” cam will fit on the mating surface of the base 4.

10.2. If the “A” or “C” cam fits on the hub of the base, proceed to Step 10.

10.3. If cam “A” or “C” does not fit on the hub of the teeter lever base 4, remove it and determine whether or not cam “B” or “D” can be installed on the hub of teeter-lever base 4 in the same position (see Fig. 11).

10.4. If cam “B” or “D” fits onto the hub of the base 4, proceed to Step 9. If it does not, **replace the complete teeter-lever assembly.**

11. For Teeter Lever Assembly P/N 50530211-04 only, install the resilient lock cam 13, torsion spring 14, and Cotter pin 15 onto cam assembly 12 (see Fig.12)

12. Install the cam assembly 12 on the teeter-lever base 4 (Fig. 13) with the keys down and the three screw holes in the cam aligned with the threaded holes in the base 4. (Fig.13, 14)

13. Place “Loctite” #262 (item 7, Fig. 15) on the surface of three new screws 8. Loctite should be placed on four to five threads located approximately 3/16” above the end of the screw, as shown in Fig.15.

14. Place one drop of Loctite #262 in each of the threaded holes in the teeter lever base 4.

15. Insert the three Loctite #262 coated screws 8 through the holes of the cam 3 into the threaded holes of the base 4. Tighten each screw to a torque of 55 inch-lbs.

16. Install emergency release cam 2 and retaining E-ring 1.

J. TEST AND INSPECTION:

1. Turn on air and electric power to the door operator.
2. Open and close the door by operating the driver's door controller. Ensure that the teeter lever and associated linkages function properly.
3. Check the functioning of the door open emergency actuation system as follows:
 - 3.1 Pull the emergency release linkage
 - 3.2 Verify that the door can be pushed open manually
 - 3.3 Activate driver door control to "Rear Door Open" position and verify that manual release linkage automatically resets.

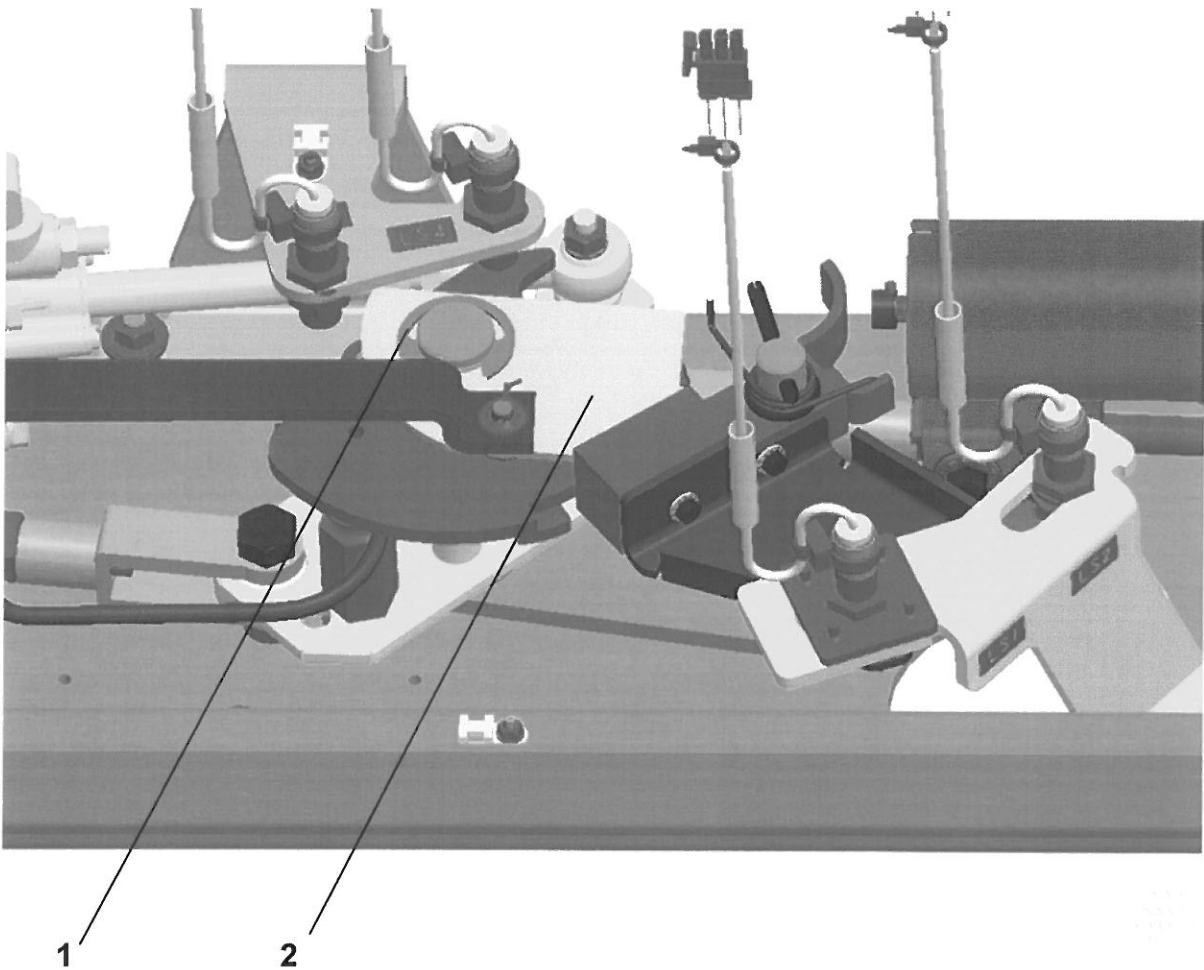

Fig.1 Location of the teeter-lever on the Base Plate.
1- retaining ring, 2- emergency cam

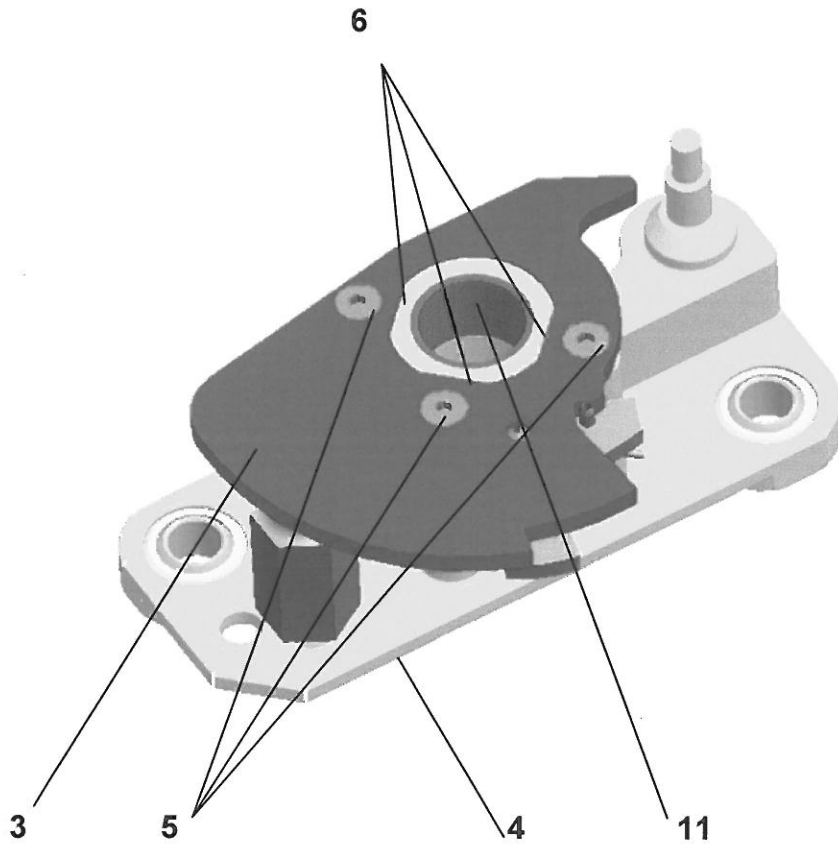

Fig. 2 Teeter lever assembly

3- cam; 4- teeter lever base; 5- screws attaching cam 3 to teeter lever base 4; 6- lead surfaces of the cam; 11- bronze bearing.



Figure 3. Welded Teeter Lever Assembly. Note weld bead at joint of base and hub and absence of cam plate attachment screws.

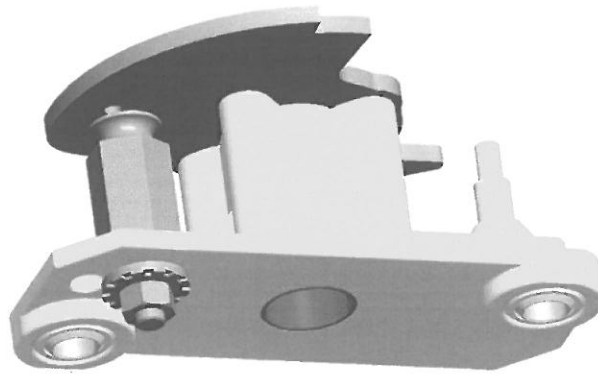

Figure 4 P/N 50530211-02 Mechanically Fastened Teeter Lever Assembly without Resilient Lock

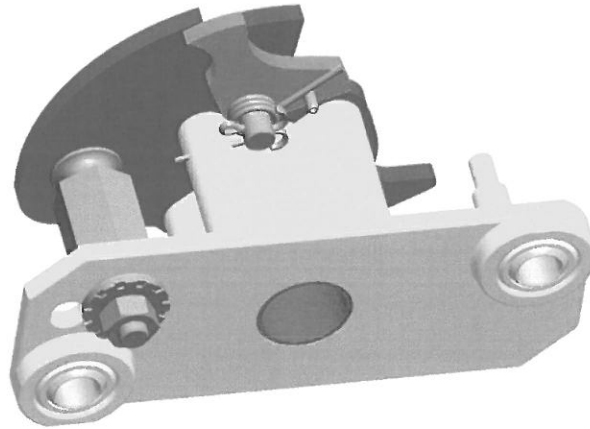

Figure 5 P/N 50530211-04 Mechanically Fastened Teeter Lever Assembly with Resilient Lock

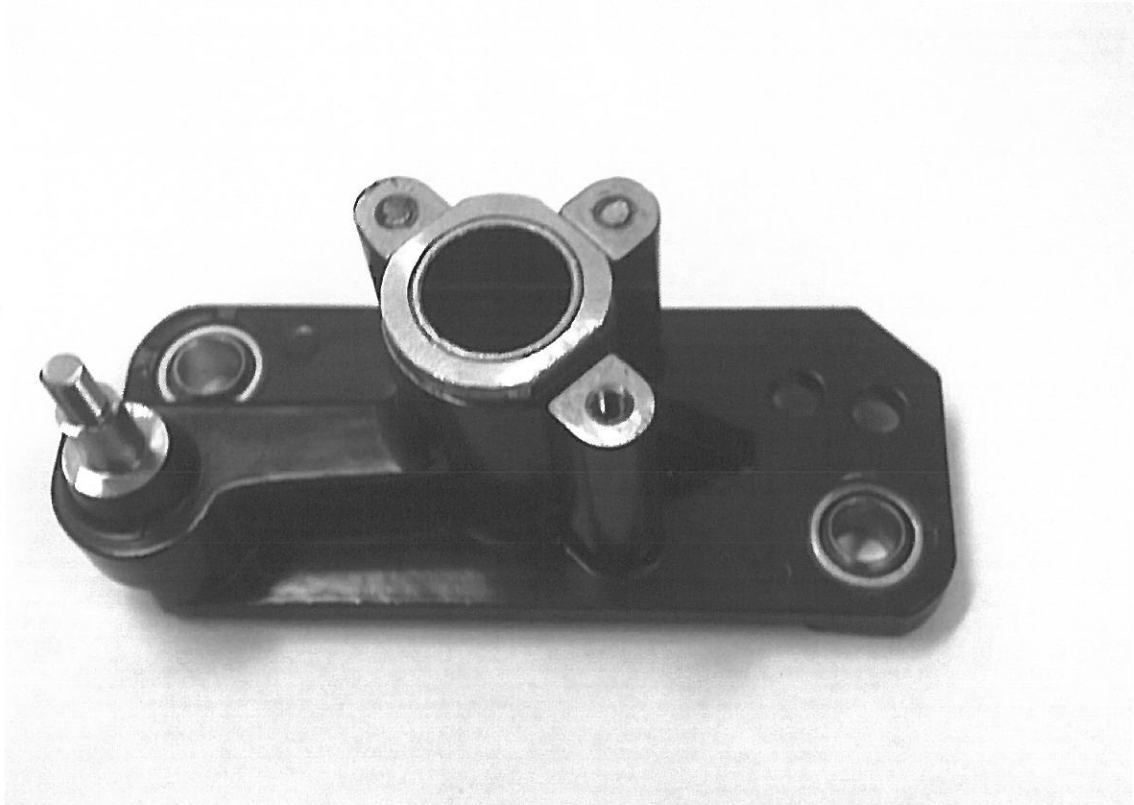

Figure 6 Teeter Lever Base with broken Cam attachment screws

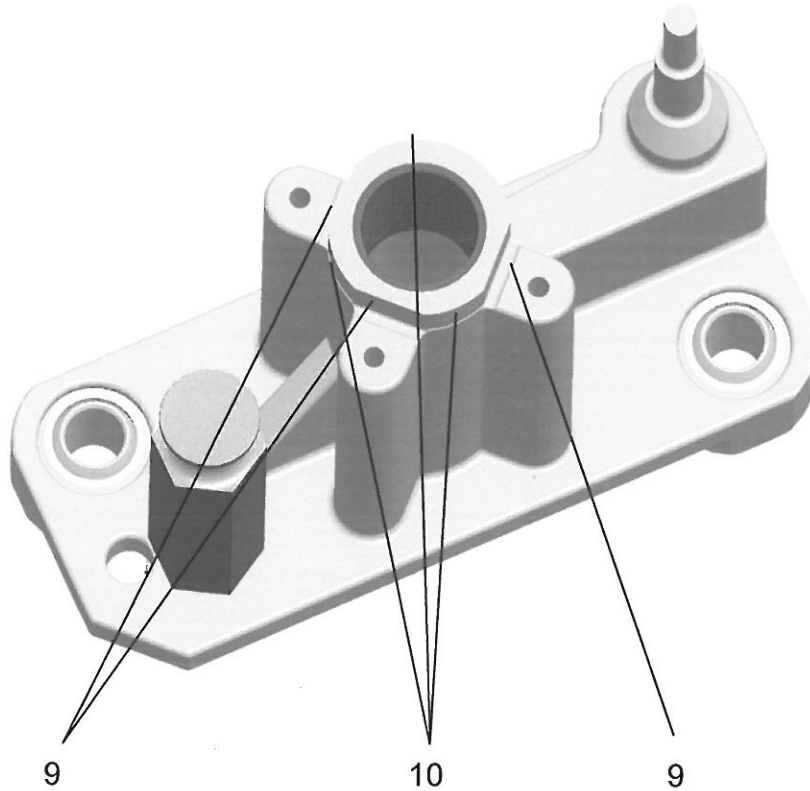

Figure 7 Teeter lever base 9- Flat driving surfaces of the base, 10 – round surfaces

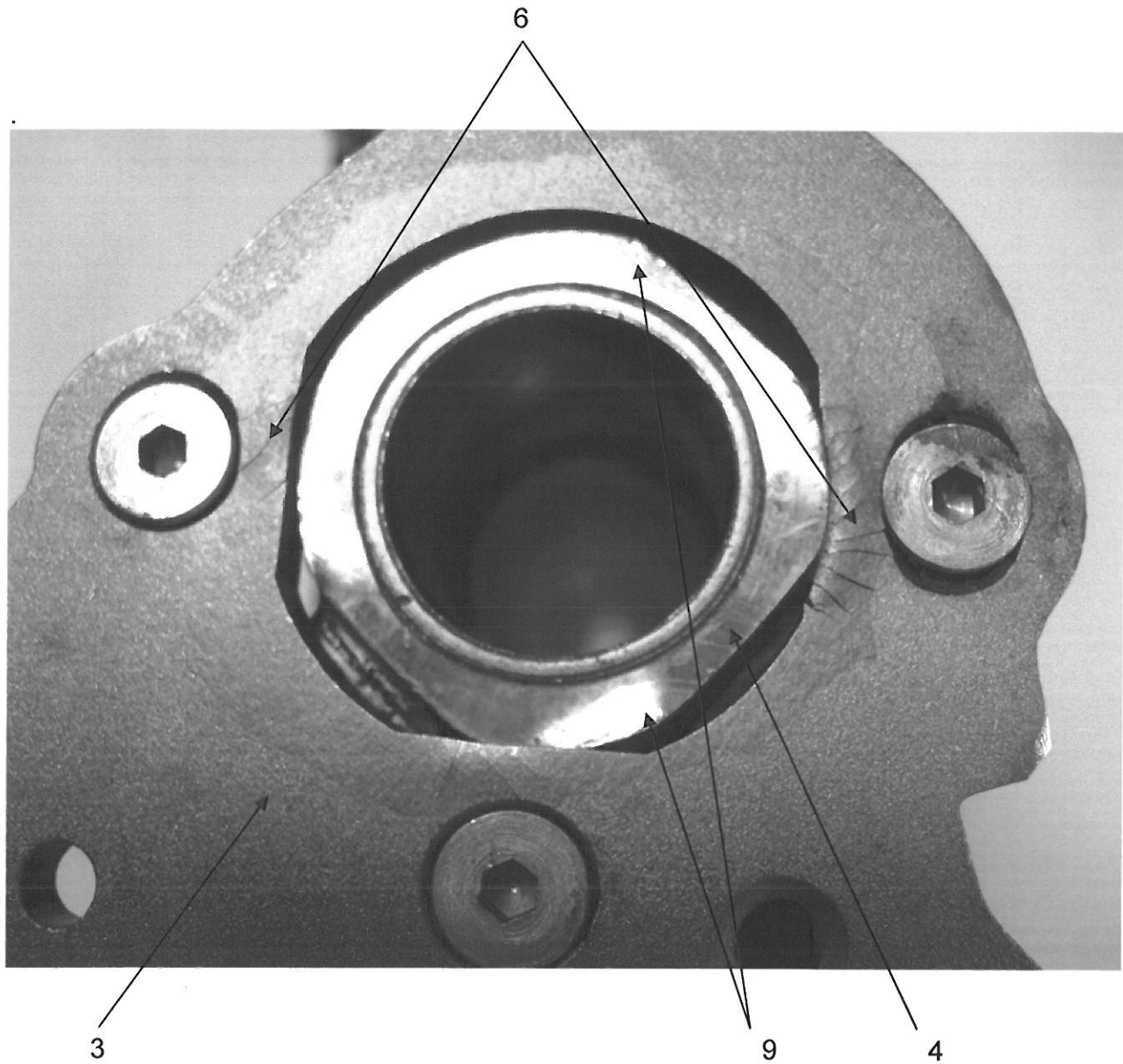

Fig. 8 Teeter lever with damaged leading surfaces of the base and cam
3- Cam, 4- base, 6- damaged surfaces of the cam, 9- damaged surfaces of the base.



Top



Bottom

Fig. 9 Top and Bottom views of the new cams 50726261 and 50726261-01
(Used for modification of teeter lever assembly 50530211-04 - with resilient lock)



Top

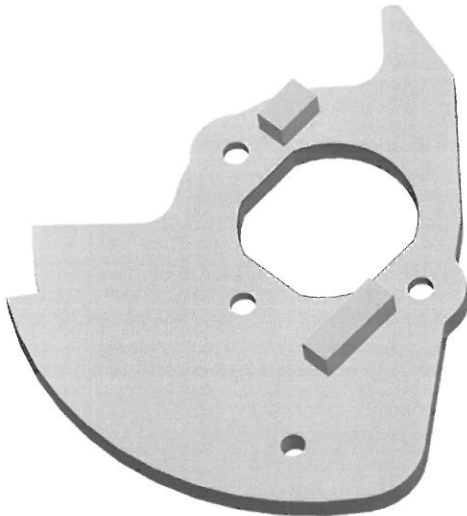

Bottom

Fig. 10 Top and Bottom views of the cam 50626261-03 and 50626261-04
(Used for modification of teeter lever assembly 505530211-02- no resilient lock).

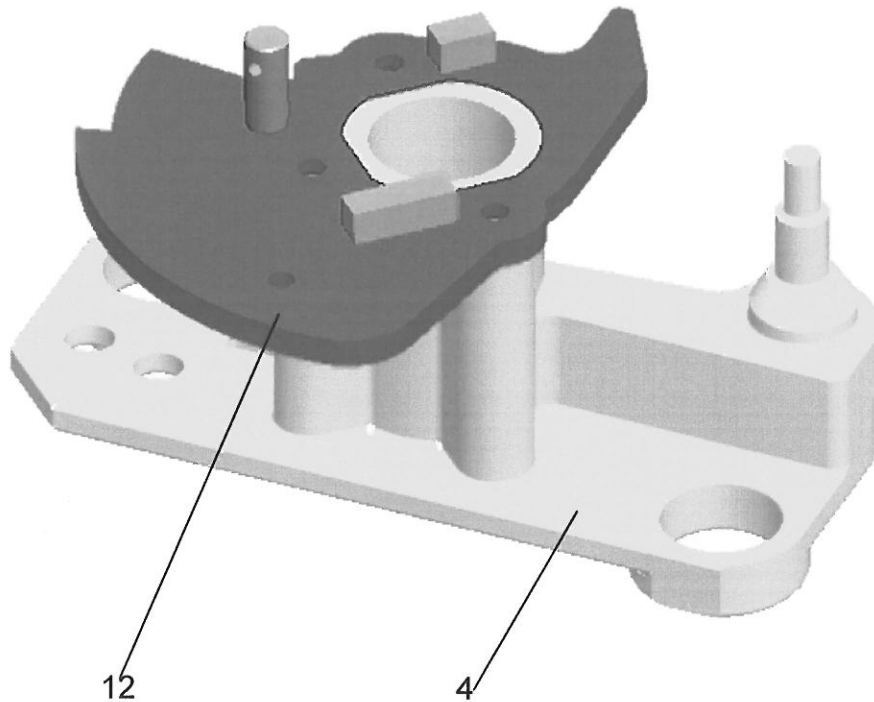

Fig. 11 New cam 12 with anti-rotational keys **temporarily** installed on the top of the hub of the base 4 to determine which cam (“A” or “B” in assembly 50530211-04; and “C” or “D” in assembly 50530211-02 respectively) should be used to retrofit the teeter lever assembly. **Note that the cam is shown inverted from the normal position.**

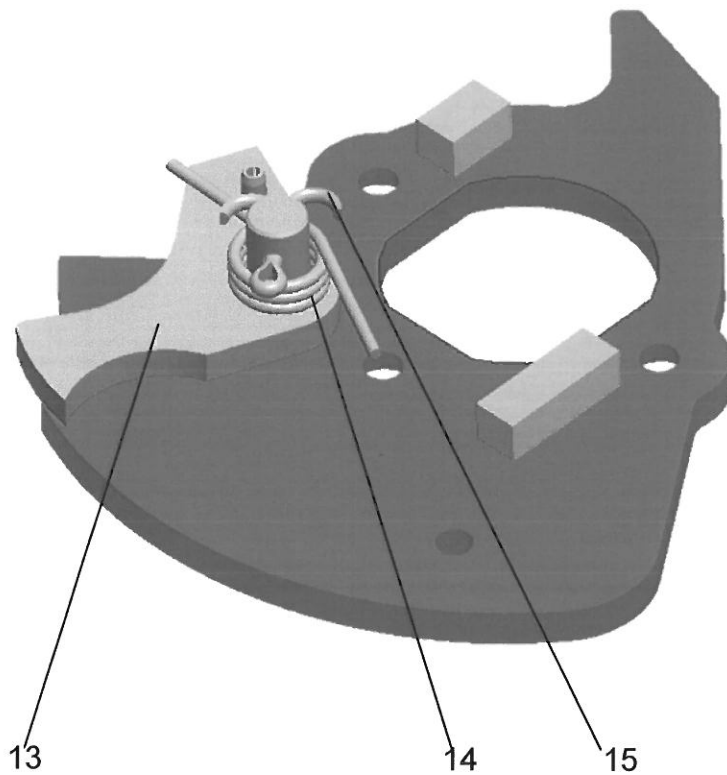

Fig. 12 Cam 50726261 assembled with resilient lock and torsion spring.
13--Cam, 14--torsion spring, 15--Cotter pin

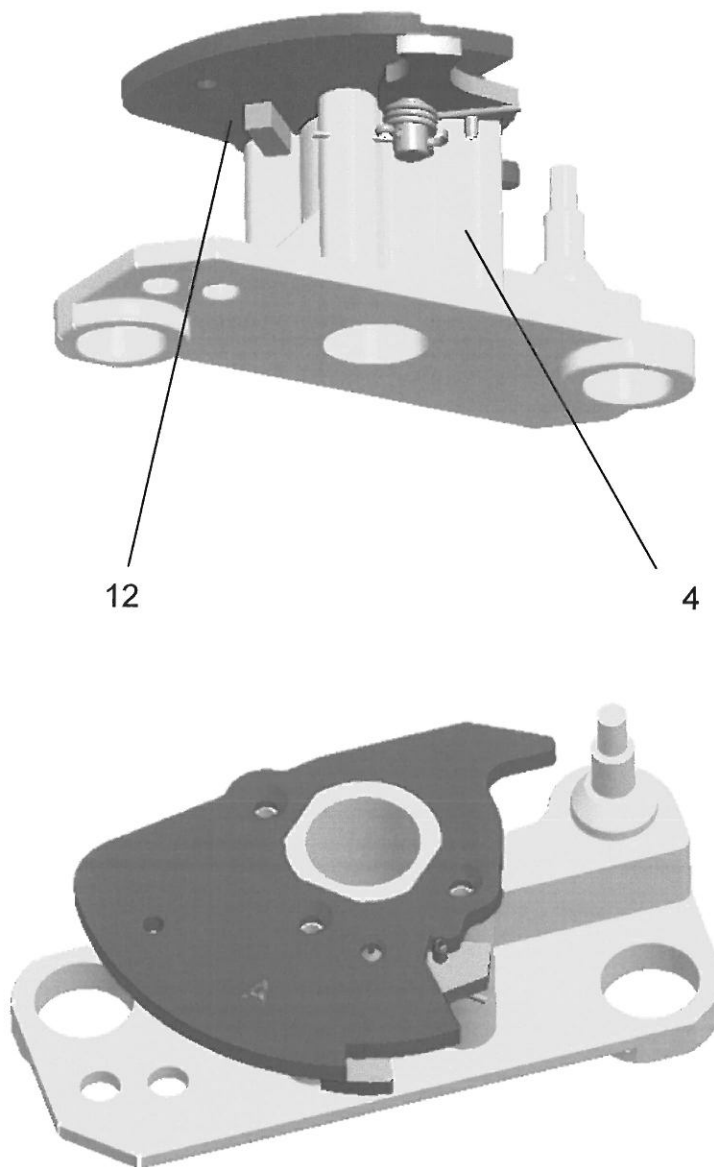

Fig.13 Cam 50726261, and 50726261-01 installed on teeter lever base.

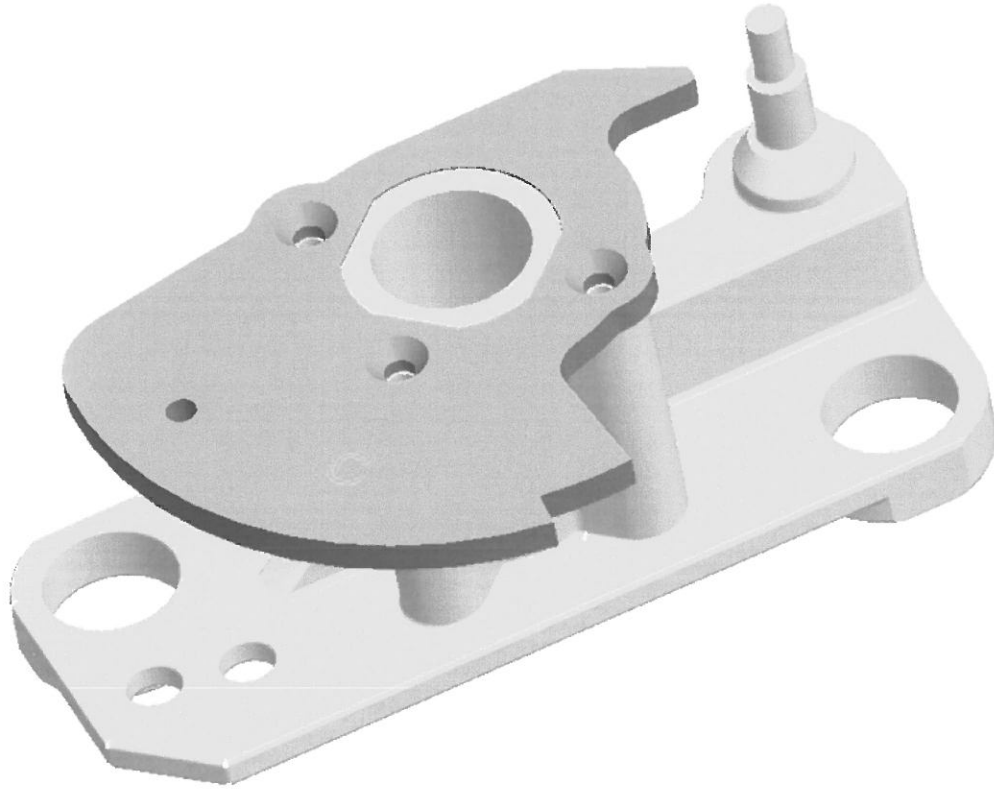

Fig.14 Cam 50626261-02 and -03 installed on teeter-lever base.

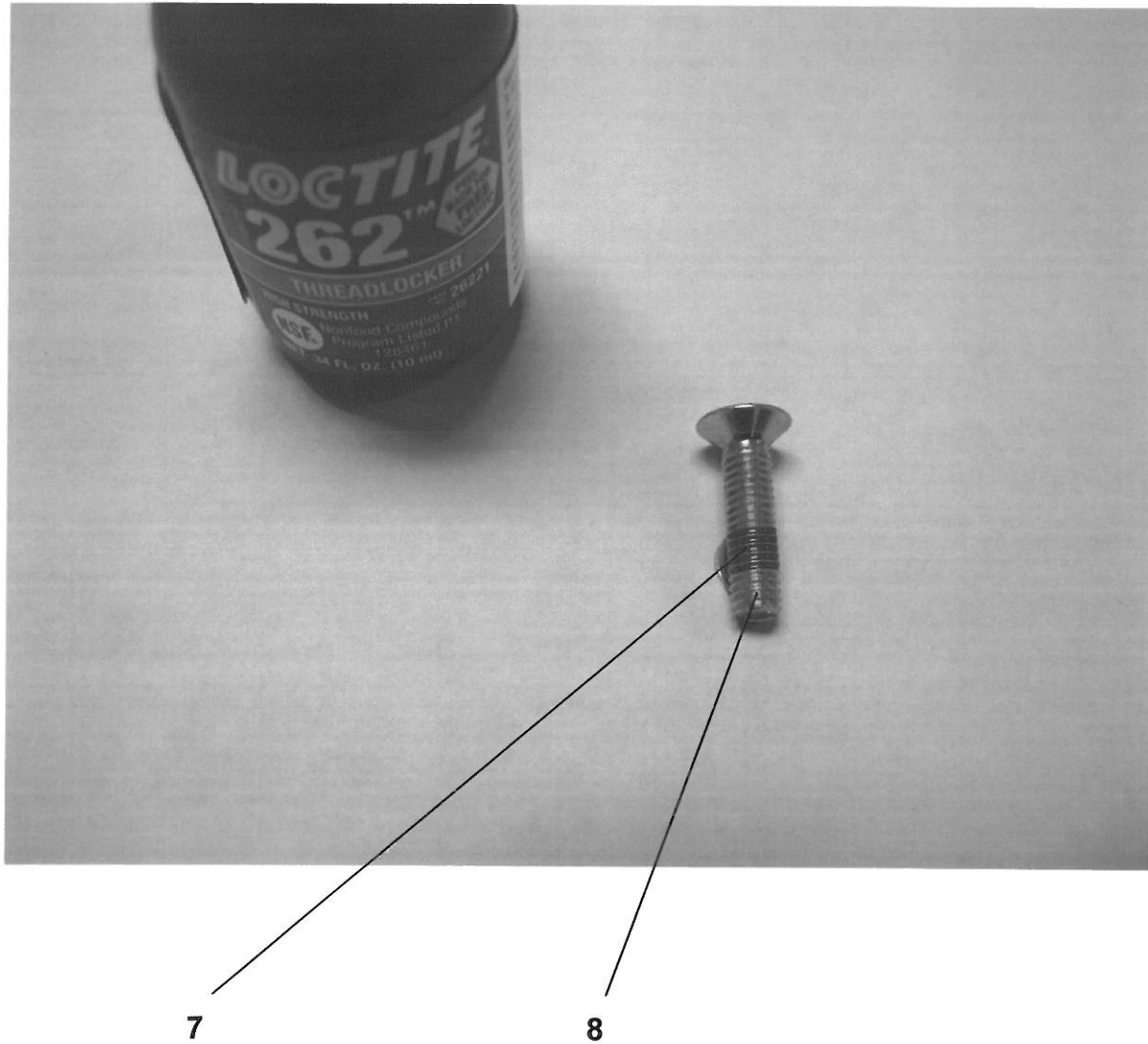

Fig. 15 Flat head hex socket cap screw six with a Loctite #262 (item 7) on its surface.
7- Loctite #262, 8-alloy steel flat head hex socket cap screw (three pcs. required per assembly),