



Date	Group.	No.	Page
05.11	SC0351		1(3)

Fifth Wheel Mounting Bolts

SAFETY RECALL INFORMATION:

Mack Trucks North America (Mack), has decided that a defect relating to motor vehicle safety may exist in certain Mack, CHU and CXU model vehicles manufactured from January 2008 to July 2010.

The concern is that there may be interference with the fifth wheel mounting bolts used to secure the fifth wheel to the frame. This interference can prevent the bolts from being torqued to specification. If this occurs, the bolt(s) may fail, which in extreme cases may result in the fifth wheel coming loose.

VEHICLES AFFECTED:

Certain Mack, CHU and CXU model vehicles manufactured from January 2008 to July 2010.

VEHICLE IDENTIFICATION NUMBERS (VIN):

There are one thousand eight hundred sixty nine (1,869) vehicles affected by this recall.

Repair

Required Parts

Qty. (12) 25189745 Flange Screw

Qty. (12) 25093559 Nut

1. Inspect the fifth wheel mounting bolts. If the bolts are hitting or there is interference complete the following procedure. If the bolts are not hitting or no interference is occurring, no further action is required.
2. Park the vehicle on a level surface with the transmission in neutral and wheels chocked.
3. Remove all fasteners mounting the fifth wheel to the fifth wheel brackets.
4. Install the new fasteners mounting the fifth wheel to the fifth wheel angles and torque to 320 Nm ± 50 Nm (236 ft-lb ± 37 ft-lb).

NOTE: Ensure the fifth wheel is aligned properly and has not moved from its original mounting location.

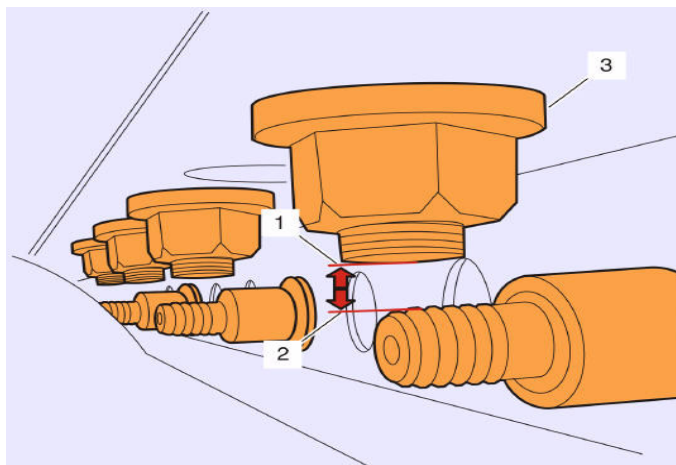

Reimbursement

This repair is covered by an authorized Safety Recall campaign. Reimbursement is obtained through the normal claim handling process.	
Claim Type (used only when uploading from the Dealer Bus. Sys.)	40
Recall Status	
Vehicle inspected, repair not included	1-Inspected, Ok
Vehicle repaired per instructions	2-Modified per instructions
Labor Code	
Primary Labor Code	1534E-01-95 0.3 hr.
Time to take charge of vehicle and determine campaign status	101AA-0A-00 - 0.3 hr.
Causal Part	25153258
Authorization No.	SC0351

The Primary Labor Code shown above includes inspection and repair.

Take-charge time is not included in the labor code for this operation. Take charge may be eligible, but can only be

used once per vehicle repair visit. If the vehicle is having other warranty repairs performed, take-charge should be charged to the warranty repair, otherwise take-charge can be charged to this Safety Recall campaign.

NOTE: Dealers are to perform Safety Recall Campaigns on all subject vehicles at no charge to the vehicle owner regardless of mileage, age of vehicle or ownership (original purchaser or subsequent purchasers). Whenever vehicles are subject to a safety recall are brought to your dealership for service, or taken into your dealership vehicle inventory, it is strongly recommended that every effort be made to perform the recall correction before the vehicle is sold or released to the owner.