



## Safety Recall: Driver's and Front Passenger's Door Window Glass Are Separated From the Regulators

(Replaces 11-009, *Front Door Window Glass Is Separated From the Regulator*, dated March 22, 2011)

### BACKGROUND

NOTE: Some vehicles need only the front passenger's door window glass replaced. Refer to Service Bulletin 11-018, *Safety Recall: Front Passenger's Door Window Glass Is Separated From the Regulator*, for VIN, warranty, and repair information.

The incorrect primer was used on the window when it was glued to the holders that attach the window to the regulator. The window can then separate from the regulator and may come off the track, causing the window to stop working and preventing it from being rolled up or down. In the worst case, the window may fall into the door and shatter, causing driver distraction and/or injury.

### CUSTOMER NOTIFICATION

Owners of affected vehicles will receive a notification of this campaign. An example of the customer notification is at the end of this service bulletin.

Not all vehicles within the affected VIN range are affected by this campaign. To verify vehicle eligibility, you **must** check at least one of these items:

- The customer has a notification letter.
- The vehicle is shown as eligible on a VIN status inquiry.

In addition, check for a punch mark above the third character of the engine compartment VIN. A punch mark in that location means this campaign has already been completed.

Some vehicles affected by this campaign may be in your new vehicle inventory. As a matter of federal law, these vehicles **must** be repaired before they are sold.

Should a dealership sell an unrepaired vehicle that subsequently causes injury or damage because of the recalled item, the dealership will be solely responsible to the damaged party, and will be required to defend and indemnify American Honda for any resulting claims. To see if a vehicle in inventory is affected by this campaign, do a VIN status inquiry before selling it.

### CORRECTIVE ACTION

Replace the driver's and front passenger's door window glass.

### PARTS INFORMATION

Right (Passenger's) Front Window:  
 P/N 73300-TK8-A00 - LX only  
 P/N 73300-TK8-A10 - All except LX

Left (Driver's) Front Window:  
 P/N 73350-TK8-A00 - LX only  
 P/N 73350-TK8-A10 - All except LX

### WARRANTY CLAIM INFORMATION

Operation Number: 8261B3

Flat Rate Time: 0.6 hour

Failed Part: P/N 73300-TK8-A10

Defect Code: 5GF00

Symptom Code: R7400

Skill Level: Repair Technician

## REPAIR PROCEDURE

NOTE: The driver's side is shown; the passenger's side is similar.

1. Lower the glass fully. If the glass is separated from the glass holder, hold the power window DOWN switch until the window regulator stops running.
2. Remove the door mirror cover by using your hand to carefully pull out the top edge of the door mirror cover to release the hooks and detach the clips.

### NOTE:

- If equipped, disconnect the BSI alert indicator connector.
- Be careful when removing and installing the door mirror cover, as the lower edge can damage the door panel.

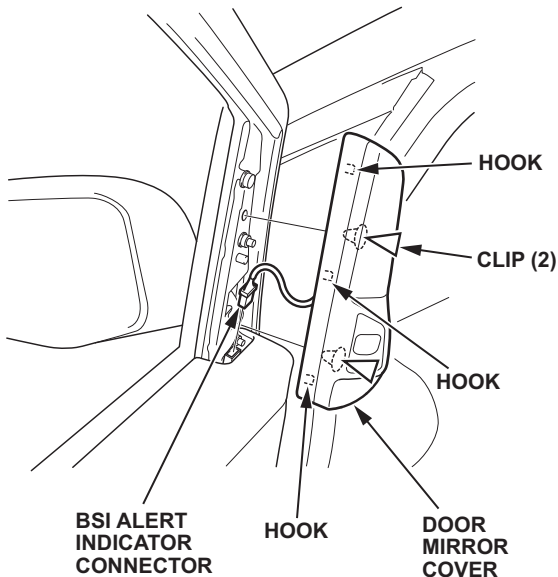

3. While pushing on the upper hook with the appropriate trim tool, pull back the inner handle cap, and release the lower hooks to remove it. Remove the two screws.

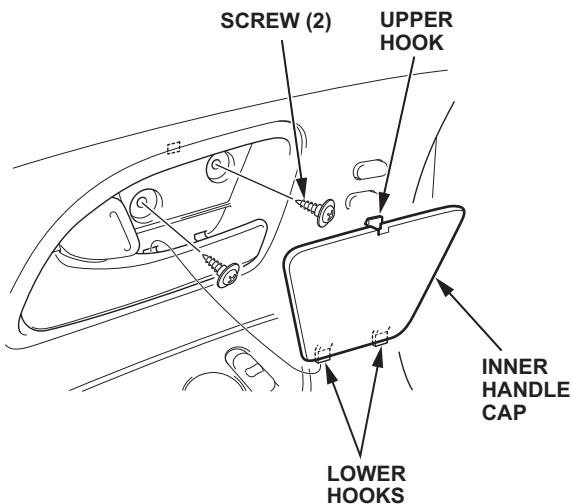

4. Remove the power window switch panel:
  - Insert the appropriate trim tool in the slot at the power window switch panel, and pry up to detach the rear clip.

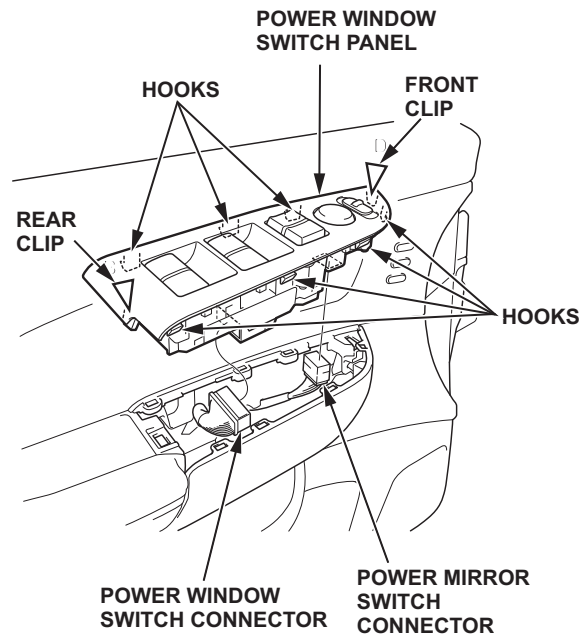

- Pull out along the edge of the panel to release the hooks and the front clip.
  - Disconnect the power mirror switch connector and the power window switch connector.
5. Remove the two screws, then pull the door panel toward you to release the 11 clips. Starting at the rear, pull the door panel upward to release it from the door.

NOTE: The inner handle cable and the latch are connected to the inner handle. Do not pull up the door panel too far, or the cables will be damaged.

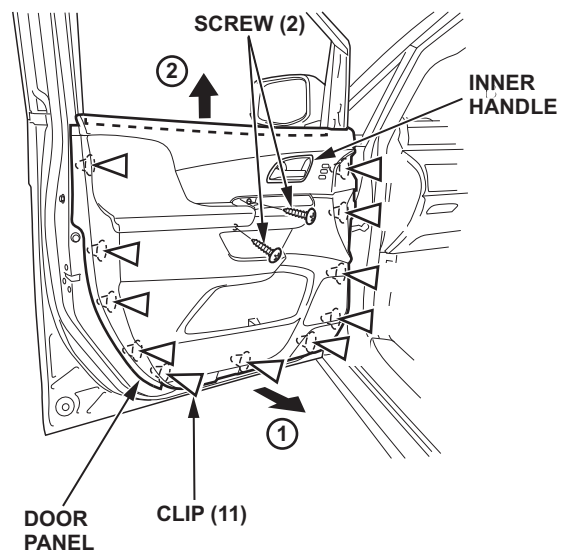

- While holding the door panel away from the door, remove the inner handle from the door panel by releasing the hooks.

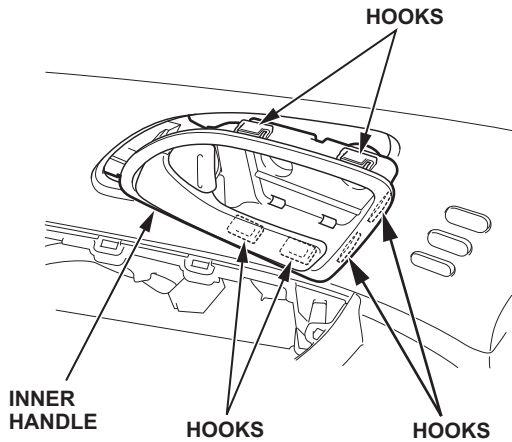

- Remove the door panel while pulling out the inner handle through the hole in the door panel. While holding the door panel away from the door, disconnect the courtesy light connector.

NOTE: If equipped, disconnect the power mirror control unit connector and the driving position memory switch connector.

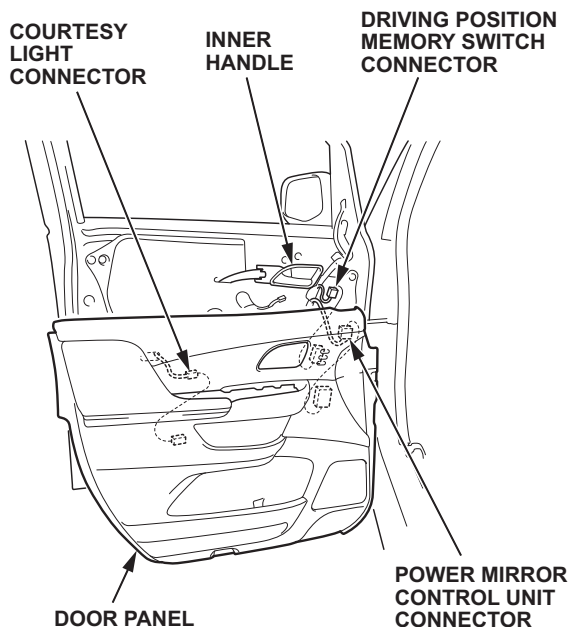

- Peel up the lower portion of the plastic cover to expose the two access holes.

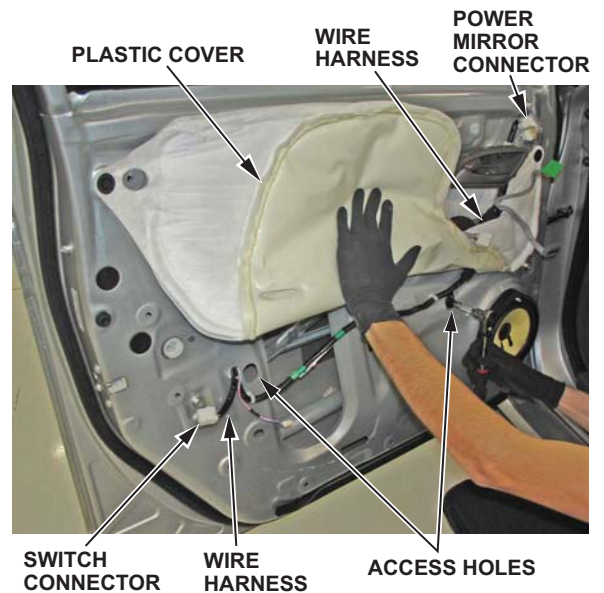

- Connect the window switch, and remove the glass:
  - If the glass is attached to the holders - Raise the glass until you can see the bolts in the access holes, then remove them. Carefully pull out the glass through the window slot.
  - If the glass is not attached to the holders - Carefully pull the glass out through the window slot. Operate the regulator until the glass holder bolts are visible in the access holes, then remove the bolts and the holders.

NOTE: Take care not to drop the glass inside the door.

- Install the new glass in the door, and torque the two glass holder bolts to **9.4 N·m (6.9 lb-ft)**.
- Raise and lower the window glass to make sure it moves freely without binding. When you close the window, also make sure there that there is no clearance between the glass and the glass run channel.
- Install the door panel, and note these items:
  - Make sure each connector is plugged in properly, and that each cable is connected securely.
  - Make sure the power window, the power door lock, and the power mirror operate properly.
  - When reinstalling the door panel, make sure the plastic cover on the door is installed properly.
  - Push the clips and the hooks into place securely.
- Reinstall the mirror cover.
- Do the POWER WINDOW CONTROL UNIT RESET procedure.
- Repeat steps 1 thru 14 to replace the other front door window.

16. Center-punch a completion mark above the third character of the engine compartment VIN:

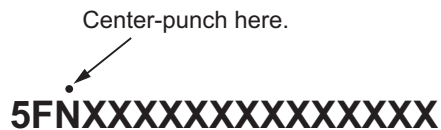

### POWER WINDOW CONTROL UNIT RESET

NOTE: Do the reset procedure for both windows.

1. Turn the ignition switch to ON (II).
2. Use the power window DOWN switch to move the power window all the way down.
3. Open the door that you are doing the reset procedure on.
4. Erase the AUTO UP feature by repeating the following bullet steps four times:  
NOTE: Make sure you do each bullet step within 5 seconds of each other. If you do not, the procedure will time out, and not work.
  - Turn the ignition switch to LOCK (0).
  - Push and hold the power window DOWN switch.
  - Turn the ignition switch to ON (II).
  - Release the power window DOWN switch.
5. Confirm that AUTO UP no longer works. If it does, repeat step 4.
6. Lower the power window all the way down using the power window DOWN switch.
7. Raise the power window all the way up using the power window UP switch. Hold the switch for several seconds after the window is closed.
8. Confirm that the power window control unit is reset by checking the AUTO UP and AUTO DOWN functions. If the AUTO UP and AUTO DOWN functions do not work, go to step 1, and repeat the resetting procedure. Pay close attention to the 5 second time limits in step 4.  
If the AUTO UP and AUTO DOWN functions still do not work, troubleshoot the power window circuit.

#### Example of Customer Letter

April 2011

#### Safety Recall: Driver's and Front Passenger's Door Window Glass Are Separated From the Regulators

Dear Odyssey Owner:

This notice is sent to you in accordance with the requirements of the National Traffic and Motor Vehicle Safety Act.

#### What is the reason for this notice?

Honda has decided that a defect which relates to motor vehicle safety exists in certain 2011 model year Odyssey vehicles. There is a potential failure with the driver and the front passenger door power windows in which the window may come off the track causing the window to become inoperative and preventing it from being rolled up or down or it could drop into the door. In the worst case, the window may shatter into the passenger cabin causing a risk of injury to the vehicle occupants.

#### What should you do?

Call any authorized Honda dealer and make an appointment to have your vehicle repaired. The dealer will replace either the front passenger door window or both front door windows, free of charge. Please plan to leave your vehicle for half a day to allow the dealer flexibility in scheduling.

#### Who to contact if you experience problems.

If you are not satisfied with the service you receive from your Honda dealer, you may write to:

American Honda Motor Co., Inc.  
Honda Automobile Customer Service  
Mail Stop 500-2N-7A  
1919 Torrance Blvd.  
Torrance, CA 90501-2746

If you believe that American Honda or the dealer has failed or is unable to remedy the defect in your vehicle, without charge, within a reasonable period of time (60 days from the date you first contact the dealer for a repair appointment), you may submit a complaint to:

Administrator  
National Highway Traffic Safety Administration  
1200 New Jersey Ave., SE  
Washington, DC 20590

Or, call the toll-free Safety Hotline at 888-327-4236 (TTY 800-424-9153), or go to <http://www.safercar.gov>.

#### What to do if you feel this notice is in error.

Our records show that you are the current owner or lessee of a 2011 Odyssey involved in this campaign. If this is not the case, or the name/address information is not correct, please fill out and return the enclosed, postage-paid Information Change Card. We will then update our records.

#### Lessor information.

Federal law requires that any vehicle lessor receiving this recall notice must forward a copy of this notice to the lessee within 10 days.

#### If you have questions.

If you have any questions about this notice, or need assistance with locating a Honda dealer, please call Honda Automobile Customer Service at 800-999-1009, and select option 4.

We apologize for any inconvenience this campaign may cause you.

Sincerely,

**American Honda Motor Co., Inc.**  
**Honda Automobile Division**

March 22, 2011

Dear Service Manager:

Honda has announced two safety recall campaigns for certain 2011 Odysseys involving front door window glass. There is a potential for the driver's and/or front passenger's door window to come off the track, causing the window to become inoperative, and preventing it from being rolled up or down. In the worst case, the window may fall into the door and shatter, causing driver distraction and/or injury.

### **Repair Strategy**

Some vehicles need only the front passenger's door window glass replaced, while other vehicles need both the driver's and front passenger's window glass replaced. Do a VIN status inquiry to determine which service bulletin applies.

For VIN, repair, tools, parts, and warranty information, refer to:

- Service Bulletin 11-018, *Safety Recall: Front Passenger's Door Window Glass Is Separated From the Regulator*, or
- Service Bulletin 11-019, *Safety Recall: Driver's and Front Passenger's Door Window Glass Are Separated From the Regulators*.

Some vehicles affected by this campaign may be in your new or used vehicle inventory. As a matter of federal law, these vehicles must be repaired before they are sold. Should a dealership sell an unrepaired vehicle that subsequently causes injury or damage because of the recalled item, the dealership will be solely responsible to the damaged party, and will be required to defend and indemnify American Honda for any resulting claims.

To see if a vehicle is affected by this campaign, make sure the customer has a notification letter, or do an iN VIN status inquiry. In addition, check for a punch mark above the third character of the engine compartment VIN. A punch mark in that location means the vehicle has already been repaired.

### **Customer Notification**

Owners of affected vehicles will receive a notification of this campaign in mid-April. An example of the customer notification is at the end of Service Bulletin 11-018 and Service Bulletin 11-019.

### **Parts Information**

An initial allocation of front windows was shipped to dealers on March 22, 2011. The allocation quantity is based on new vehicles in your inventory. Beginning the week of March 28, 2011, additional glass is available through open ordering.

Sincerely,

**American Honda Motor Co., Inc.**  
**Honda Automobile Division**