

NEW! CERTAIN 2004 THROUGH 2006 MODEL YEAR F-150 AND 2006 MODEL YEAR MARK LT VEHICLES — CLOCKSPrING TO DRIVER SIDE FRONTAL AIR BAG WIRE HARNESS REPLACEMENT

OVERVIEW

On some of the affected vehicles, it may be possible for the clockspring to driver side frontal air bag wire harness to chafe on the horn mounting plate. This may cause the air bag warning lamp to illuminate in the cluster indicating service is required. If the air bag warning lamp is ignored, this chafing may cause the driver side frontal air bag to inadvertently deploy and may result in personal injury. Dealers are to replace the clockspring to driver side frontal air bag wire harness with a service part that incorporates additional chafe protection.

SERVICE PROCEDURE

1. Remove the driver air bag. For additional information, refer to the appropriate WSM, Section 501-20B.
2. Release the clockspring connector lock and disconnect the harness from the clockspring. See Figure 1.

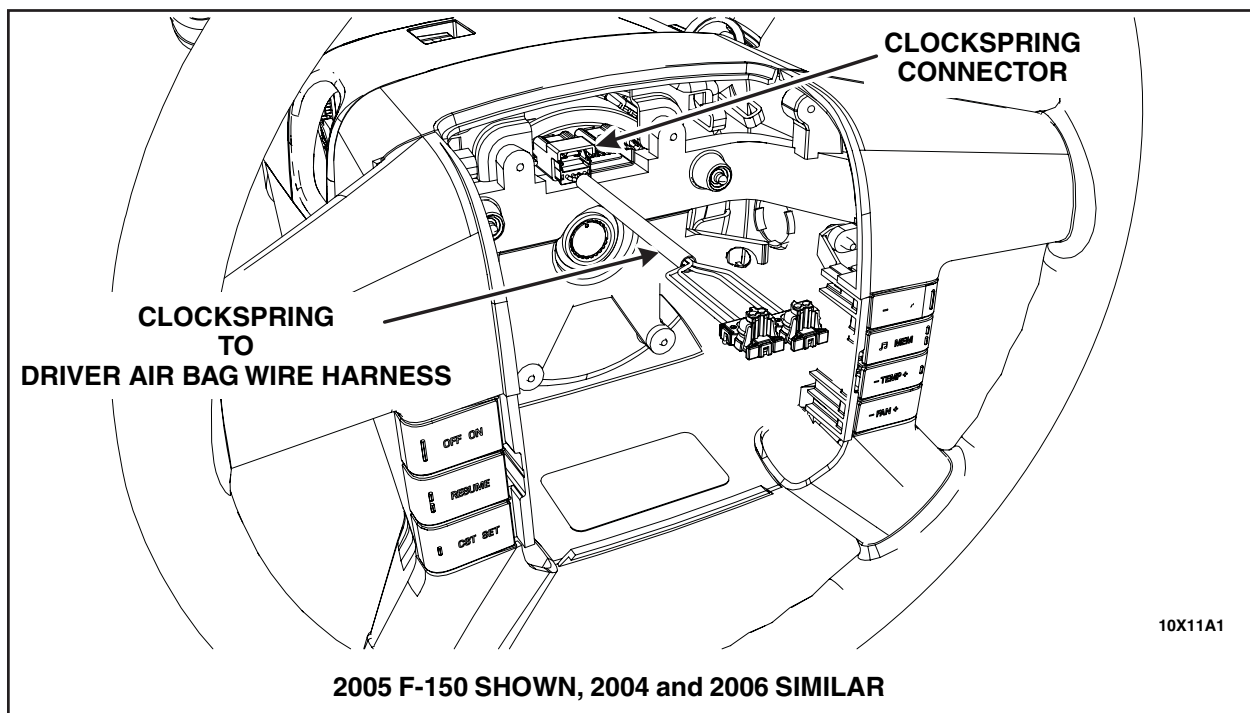

FIGURE 1

3. Install the **new** clockspring to driver air bag wire harness using the following sequence:
 1. Connect the harness to the clockspring.
 2. Make sure the harness lock at the clockspring is seated.
 3. Connect the harness to the air bag.
4. Install the driver air bag. For additional information, refer to the appropriate WSM, Section 501-20B.

