

 Applies To: **See VEHICLES AFFECTED**
February 19, 2011

Safety Recall: Lost Motion Springs

BACKGROUND

The lost motion springs in the engine's variable valve timing and lift electronic control (VTEC) may break. In rare cases, the broken pieces of the lost motion spring may jam the rocker arm and cause the engine to stall and prevent it from being restarted. An engine that stalls while driving increases the risk of a crash.

VEHICLES AFFECTED

2009 Fit

From VIN JHMGE8...9S000027
thru JHMGE8...9S075923

From VIN JHMGE8...9C000005
thru JHMGE8...9C007783

2010 Fit

From VIN JHMGE8...AC000001
thru JHMGE8...AC013589

Not all vehicles within the affected VIN ranges are affected by this campaign. To verify vehicle eligibility, you **must** check for at least one of these items:

- The customer has a notification letter.
- The vehicle is shown as eligible on a VIN status inquiry.

In addition, check for a punch mark above the 1st character of the engine compartment VIN. A punch mark in that location means this campaign has already been completed.

Some vehicles affected by this campaign may be in your used vehicle inventory. As a matter of federal law, these vehicles **must** be repaired before they are sold.

Should a dealership sell an unrepaired vehicle that subsequently causes an injury or damage because of the recalled item, the dealership will be solely responsible to the damaged party, and will be required to defend and indemnify American Honda for any resulting claims. To see if a vehicle in inventory is affected by this campaign, do a VIN status inquiry before selling it.

CUSTOMER NOTIFICATION

Owners of affected vehicles will receive a notification of this campaign. An example of the customer notification is at the end of this service bulletin.

CORRECTIVE ACTION

Inspect and, if necessary, replace the four lost motion springs.

PARTS INFORMATION

Lost Motion Spring Kit: P/N 04148-RK8-305
(Includes four lost motion spring assemblies, throttle body gasket, and four intake manifold gaskets)

TOOL INFORMATION

Rocker Arm Holder Set: T/N 070AB-RB10100
(Includes four rocker arm holders and four rocker arm spacers)

WARRANTY CLAIM INFORMATION

OP#	Description	FRT
1105B3	Disassemble the engine, inspect the production date and number on the rocker bridge, and reassemble the engine.	1.1
1101AK	Disassemble the engine, replace the four lost motion springs (including valve adjustment), and reassemble the engine.	1.6

Failed Part: P/N 14820-RB1-013

Defect Code: 5LT00

Symptom Code: R6600

Skill Level: Repair Technician

INSPECTION AND REPAIR PROCEDURE

NOTE: This procedure is in an outline form that you can also use as a checklist for the repair. If you need more details on the procedures listed below, bookmark them in the appropriate service manual, or view them online:

- Wiper Arm Replacement
- Cowl Cover Replacement
- Under Cowl Replacement
- Air Cleaner Removal/Installation
- Intake Manifold Removal and Installation
- Cylinder Head Cover Removal
- Rocker Arm Assembly Removal
- Rocker Arm Assembly Installation
- Valve Clearance Adjustment
- Cylinder Head Cover Installation

1. Remove the windshield wiper arms.
2. Remove the cowl cover.
3. Remove the under-cowl panel.
4. Remove the air cleaner.
5. Remove the intake manifold chamber assembly.
6. Remove the cylinder head cover.
7. Check the manufacturing lot number on the rocker arm bridge.

Referring to the image below, was the rocker bridge built **after** No. 215 on November 20, 2009?

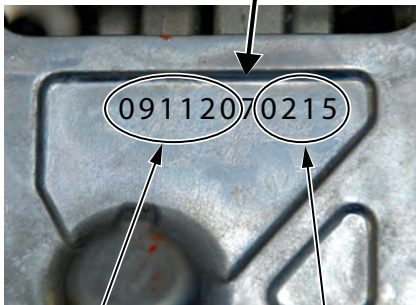
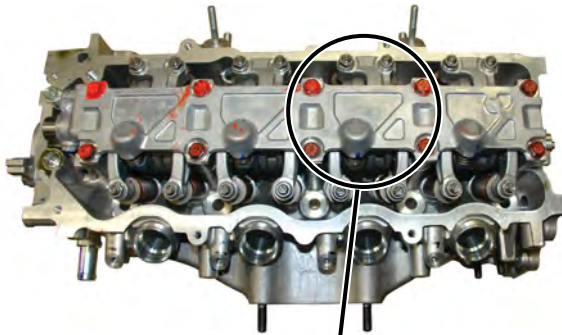

091120
2009/11/20
YEAR/MONTH/DAY

0215
PRODUCTION
NUMBER

Yes – The lost motion springs are OK. Go to step 19 to reassemble the engine.

No – Go to step 8.

8. Remove the rocker arm assembly, and place it upside-down on a clean work surface.

9. Remove the rocker shaft bolt.

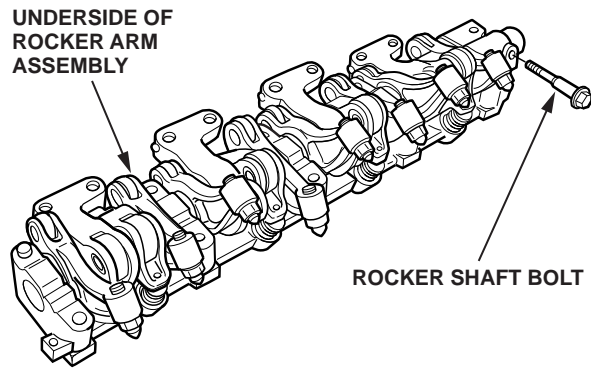

10. Use the rocker arm spacers and the rocker arm holders to keep the four rocker arm assemblies together when you remove them:

- Place a rocker shaft spacer at the cylinder No. 1 rocker arm assembly.

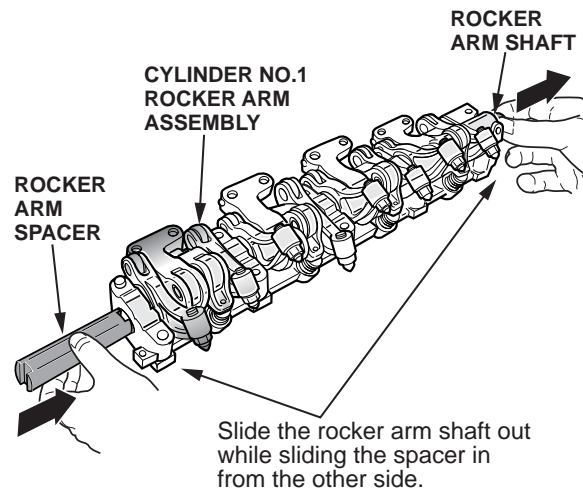

- While pushing in the rocker arm spacer, slide the rocker arm shaft out of the cylinder No. 1 rocker arm assembly. Make sure to keep the holder grooves vertical.

- When the rocker arm shaft is clear from the cylinder No. 1 rocker arm assembly, install a rocker arm holder.

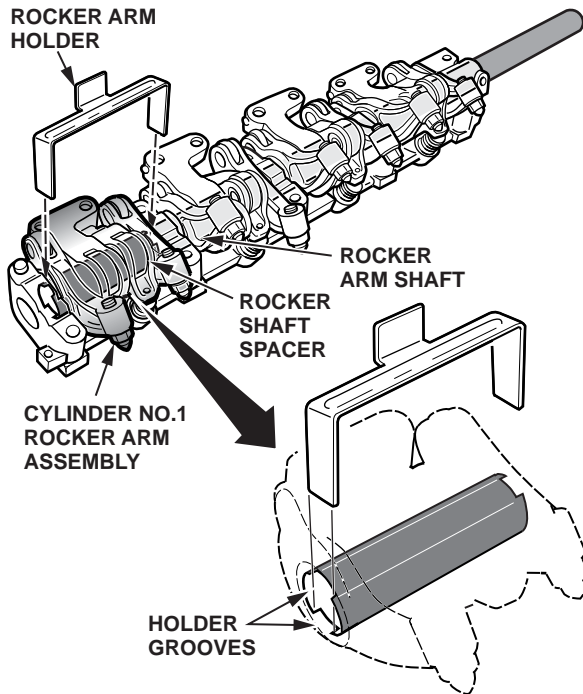

- Remove the cylinder No. 1 rocker arm assembly from the rocker bridge assembly.

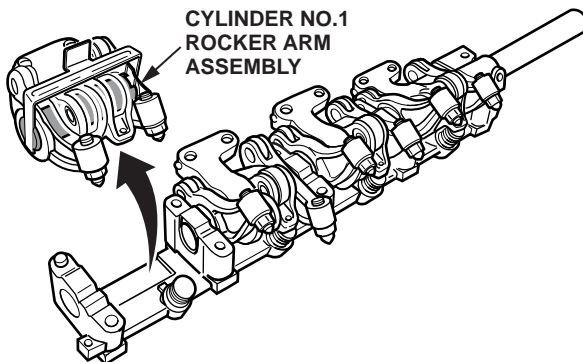

11. Repeat step 10 for the remaining three rocker arm assemblies. Note the location of each assembly to make sure they are returned to their original positions.

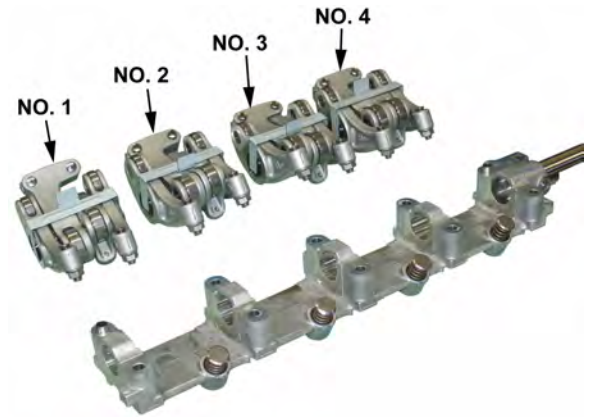

12. Remove the lost motion springs.

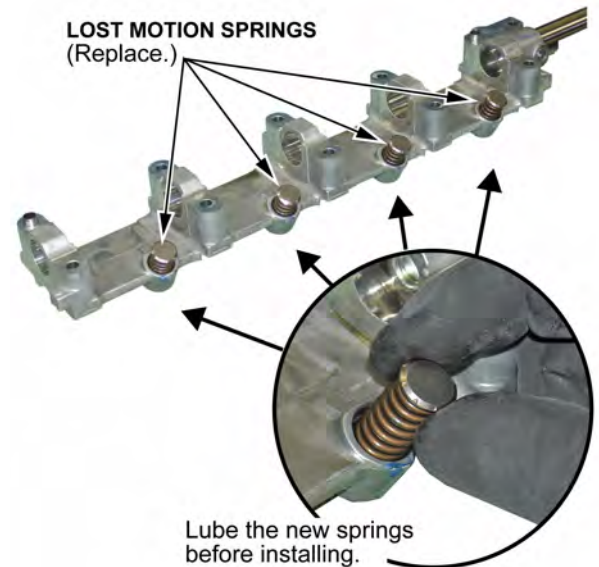

13. Lube the new lost motion springs with fresh engine oil, then install them.

14. Reinstall the cylinder rocker arm assemblies in the rocker bridge:

- Place the cylinder No. 4 rocker arm assembly in the rocker bridge.
- Remove the holder.
- Carefully slide the rocker arm shaft into the cylinder No. 4 rocker arm assembly. The rocker shaft spacer will slide out.

15. Repeat step 14 for the remaining three rocker arm assemblies.

16. Install the rocker shaft bolt, and torque it to **9 N·m (7.0 lb-ft)**.

NOTE: The rocker shaft bolt installs in one direction only. If the bolt does not go in, rotate the rocker shaft 180 degrees.

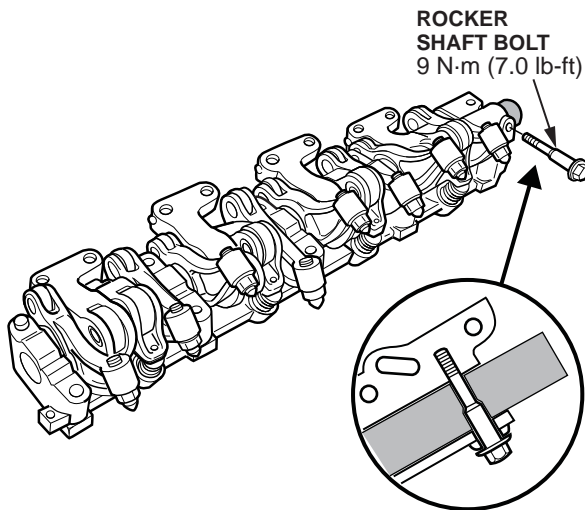

17. Reinstall the rocker arm assembly.
18. Adjust the valve clearance.
19. Reinstall the cylinder head cover.
20. Reinstall the intake manifold chamber assembly.
21. Install the air cleaner.
22. Reinstall the under-cowl panel, the cowl cover, and the windshield wiper arms.
23. Center-punch a completion mark above the 1st character of the engine compartment VIN:

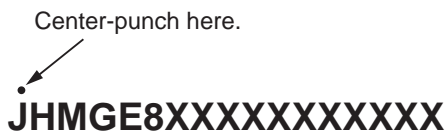

Example of Customer Letter

February 2011

Safety Recall: Lost Motion Springs

Dear Fit Owner:

This notice is sent to you in accordance with the requirements of the National Traffic and Motor Vehicle Safety Act.

What is the reason for this notice?

Honda has decided that a defect, which relates to motor vehicle safety, exists in certain 2009 and 2010 model year Fit vehicles. There is a potential for one or more of the four spring assemblies on the engine's variable valve timing and lift electronic control (VTEC) system to fail which may cause the engine to stall and prevent it from being restarted. An engine stall will increase the risk of a crash.

What should you do?

Call any authorized Honda dealer and make an appointment to have your vehicle repaired. The dealer will inspect and replace the spring assemblies in your engine if necessary. This work will be done free of charge. Please plan to leave your vehicle for a full day to allow the dealer flexibility in scheduling.

Who to contact if you experience problems.

If you are not satisfied with the service you receive from your Honda dealer, you may write to:

American Honda Motor Co., Inc.
 Honda Automobile Customer Service
 Mail Stop 500-2N-7A
 1919 Torrance Blvd.
 Torrance, CA 90501-2746

If you believe that American Honda or the dealer has failed or is unable to remedy the defect in your vehicle, without charge, within a reasonable period of time (60 days from the date you first contact the dealer for a repair appointment), you may submit a complaint to:

Administrator
 National Highway Traffic Safety Administration
 1200 New Jersey Ave., SE
 Washington, DC 20590

Or call the toll-free Safety Hotline at 888-327-4236 (TTY 800-424-9153), or go to <http://www.safercar.gov>.

What to do if you feel this notice is in error.

Our records show that you are the current owner or lessee of a 2009 or a 2010 Fit involved in this campaign. If this is not the case, or the name/address information is not correct, please fill out and return the enclosed, postage-paid Information Change Card. We will then update our records.

Lessor information.

Federal law requires that any vehicle lessor receiving this recall notice must forward a copy of this notice to the lessee within 10 days.

If you have questions.

If you have any questions about this notice, or need assistance with locating a Honda dealer, please call Honda Automobile Customer Service at 800-999-1009, and select option 4.

We apologize for any inconvenience this campaign may cause you.

Sincerely,

**American Honda Motor Co., Inc.
 Honda Automobile Division**

February 19, 2011

Dear Service Manager:

Honda has announced a safety recall campaign for certain 2009 and 2010 Fits. The lost motion springs in the engine's variable valve timing and lift electronic control (VTEC) may break. In rare cases, the broken pieces of the lost motion spring may jam the rocker arm and cause the engine to stall and prevent it from being restarted. An engine that stalls while driving increases the risk of a crash.

Repair Strategy

The repair is to inspect and, if necessary, replace the four lost motion springs. For repair, tools, parts, and warranty information, refer to Service Bulletin 11-010, *Safety Recall: Lost Motion Springs*.

Some vehicles affected by this campaign may be in your used vehicle inventory. As a matter of federal law, these vehicles must be repaired before they are sold. Should a dealership sell an unrepaired vehicle that subsequently causes an injury or damage because of the recalled item, the dealership will be solely responsible to the damaged party, and will be required to defend and indemnify American Honda for any resulting claims.

To see if a vehicle is affected by this campaign, make sure the customer has a notification letter, or do an iN VIN status inquiry. In addition, check for a punch mark above the first character of the engine compartment VIN. A punch mark in that location means the vehicle has already been repaired.

Customer Notification

Owners of affected vehicles will receive a notification of this campaign the second week of March 2011. An example of the customer notification is at the end of service bulletin 11-010.

Parts Information

Lost motion spring kits are available through open ordering.

Sincerely,

American Honda Motor Co., Inc.
Honda Automobile Division