

Technical Bulletin

Division: Automotive
 Category: Technical

Section Title: Engine
 TSB No. TS 30 02011

SUBJECT: SAFETY RECALL CAMPAIGN: SM, ALTERNATOR BELT TENSIONER DAMAGE.
MODEL(S): GRAND VITARA (JB424)
YEAR: 2009~2011
PRODUCTION RANGE: JUNE 2, 2008~OCTOBER 20, 2010

CONDITION: The internal spring of alternator belt tensioner could break, allowing the belt to slip or derail, causing abnormal noise, and in worst cases may result in increased effort to steer the vehicle.

CORRECTION: Suzuki dealers are required to perform an inquiry of the “Vehicle Master”, confirming the recall campaign is open, then replace the alternator belt tensioner pulley, unless a replacement has been previously performed with countermeasure parts. This service will be performed at no cost to the customer for parts or labor.

PART(S) INFORMATION:

Part Number	Description	Qty.	Notes
17540-54L00-RX0	Tensioner Assy, Alternator Belt	1	See fig.1
17541-54810-RX0	Bolt & Washer Set, Tensioner	1	See fig.2

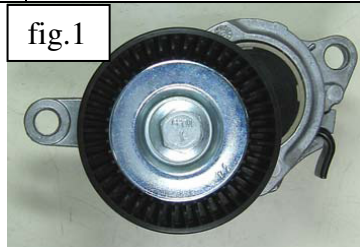

Technical Service Department
 Dealership Circulation – Initial and file:

Service Manager	Parts Manager	Service Advisor	Technicians						

Suzuki bulletins are intended for use by professional technicians, NOT a “do-it-yourselfer.” They are written to inform these technicians of conditions that may occur on some vehicles, or to provide information that could assist in the proper service of a vehicle. Properly trained technicians have the equipment, tools, safety instructions, and know-how to do a job properly and safely. If a condition is described, DO NOT assume that the bulletin applies to your vehicle, or that your vehicle will have that condition. See your authorized Suzuki dealer for information on whether your vehicle may benefit from the information. Suzuki reserves the right to change technical specifications at any time without prior notice.

WARRANTY INFORMATION

Campaign Code	Operation Code	Complaint Code	Defect Code	Labor Time
Please refer to the Campaign Bulletin SC-55 for claim submission instructions and labor times.				

WORKFLOW

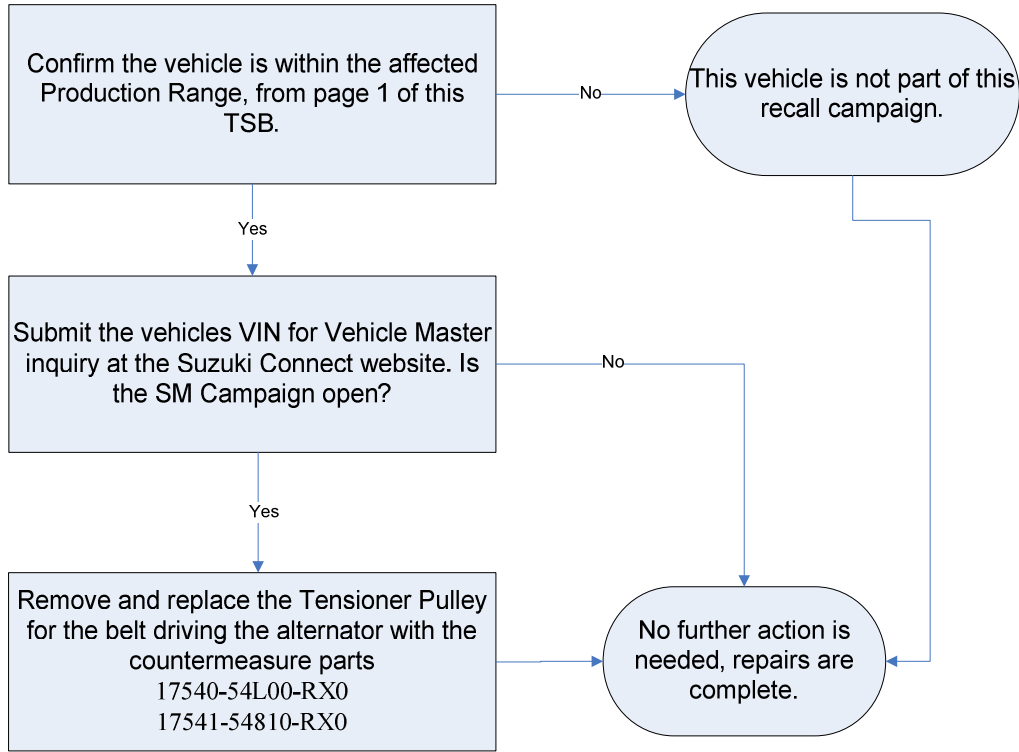

NECESSARY TOOLS

No.	Tool Name	No.	Tool Name
1	6mm Hexagon bit socket (3/8 drive)	6	12mm Deep socket (3/8 drive)
2	10mm/12mm Open end wrench	7	14mm Shallow socket (3/8 drive)
3	10mm/12mm Box wrench	8	Ratchet (3/8 drive)
4	12mm/14mm Box wrench	9	Torque wrench 18-35 lb-ft (3/8 drive)
5	10mm Deep socket (3/8 drive)		

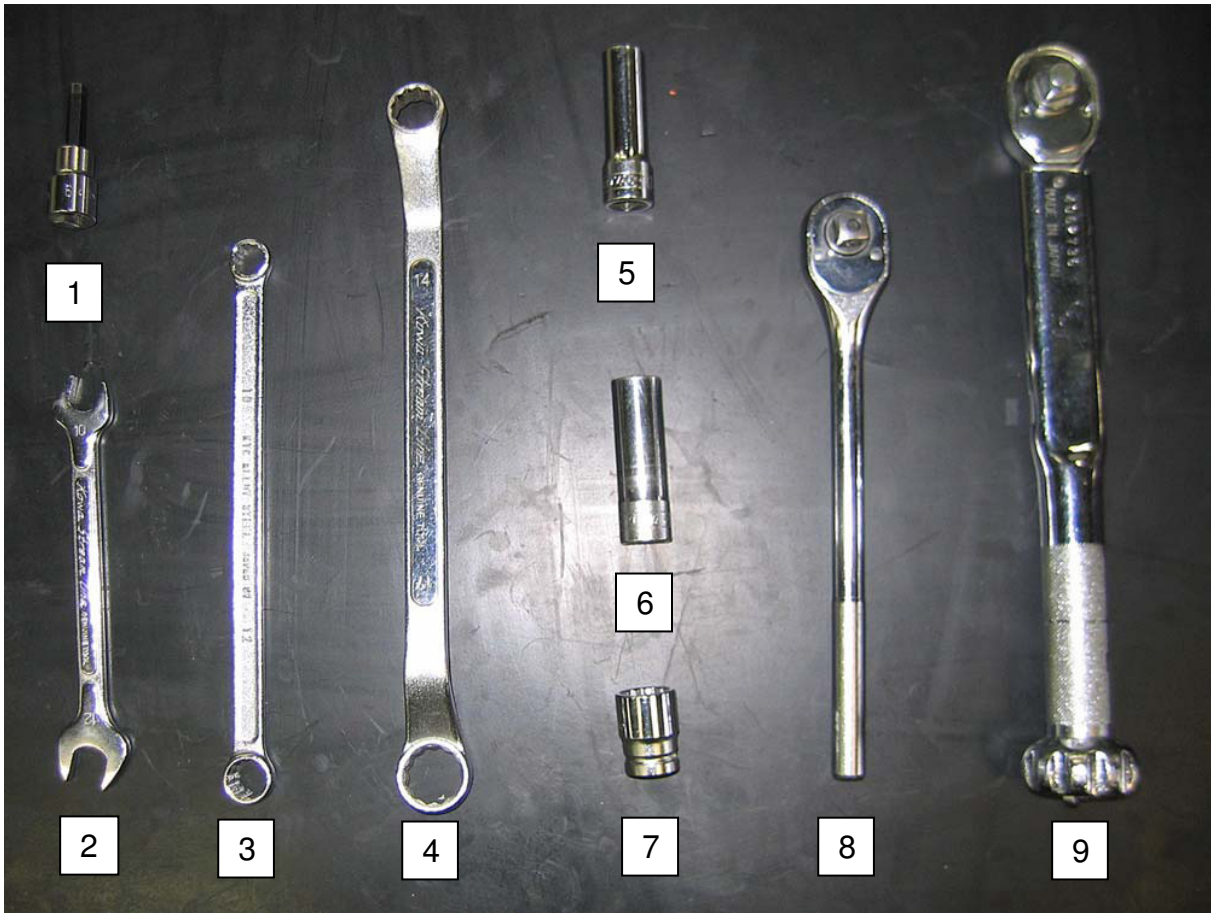

CUSTOMER SATISFACTION COURTESY

Drive Belt Inspection

Before beginning the removal process, please inspect the position of the tension indicators on the tensioner pulley, as well as the condition of the drive belt.

In cases of normal belt condition, the front tension indicator (1) (nearest the pulley) is on the right of the rear tension indicator (2), as shown in the illustration to the right.

If indicator (1) is on the left of Indicator (2), the belt should be replaced as a general service in addition to the tensioner replacement.

If it is recommended that the belt should be replaced due to the tension indicators or the visual appearance during inspection, please contact the vehicle owner to advise them of these needs. It is the customer's responsibility to pay for the cost of the replacement belt as this is not included as part of the service recall campaign.

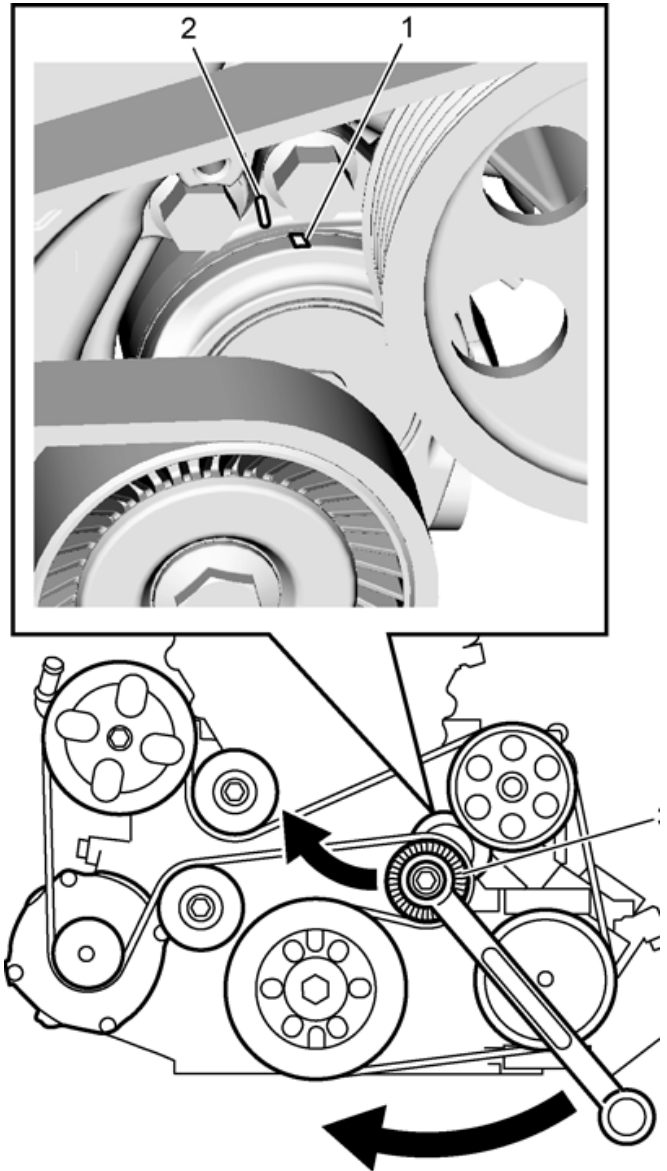

REPLACEMENT PROCEDURE OF THE ALTERNATOR BELT TENSIONER**Removal Procedure**

1. Loosen belt tension by turning the tensioner (1) clockwise with 14mm box wrench (2).
2. While keeping the tensioner in the turned position (belt loose), remove the alternator drive belt.
3. Remove the tensioner pulley bolt (1) and then pulley shield (2) and pulley (3).

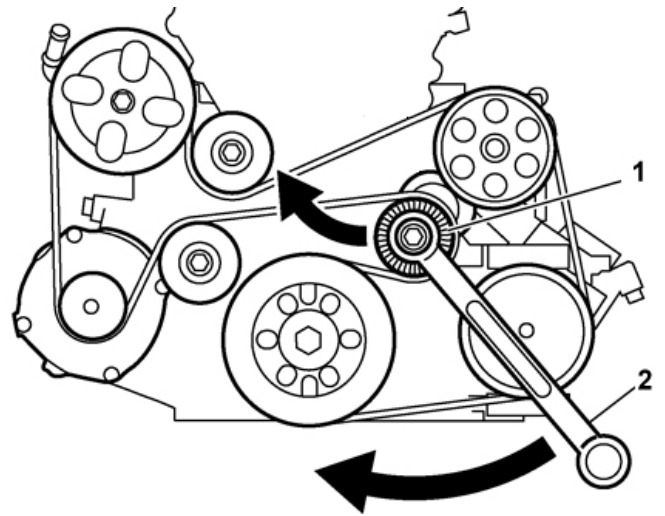

4. Remove lower side bolt (1) of the tensioner body.

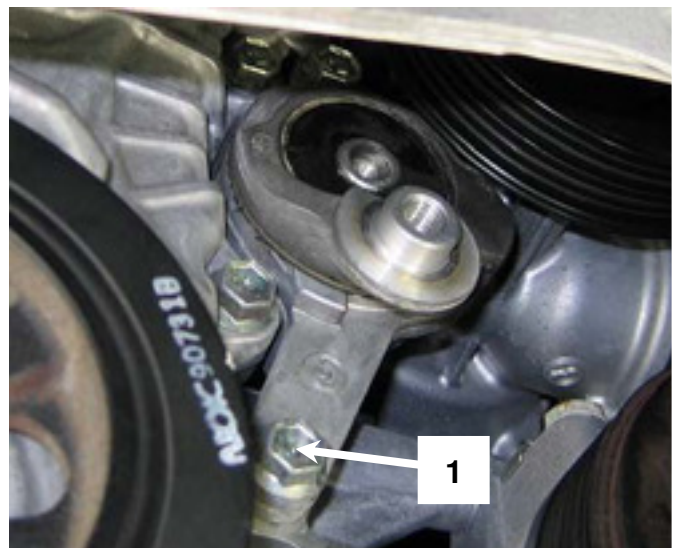
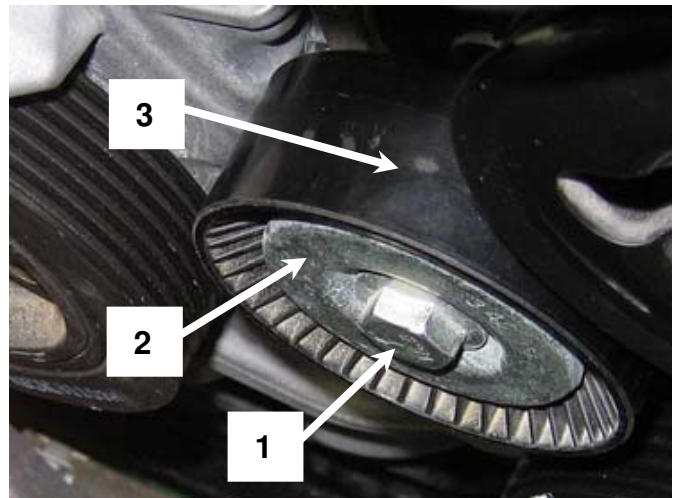

5. Inserting a box wrench through water pump side, begin to loosen the upper side bolt (1) of the tensioner body, but do not back out or remove the bolt.

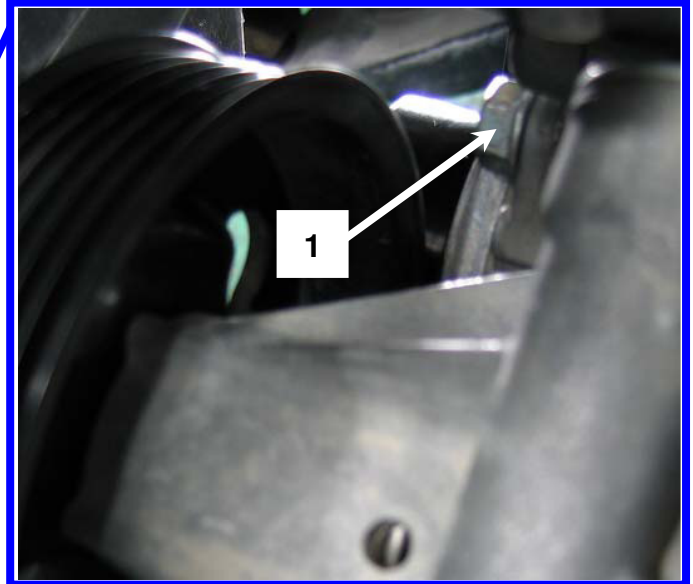
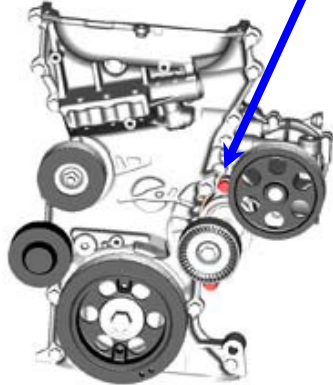

6. To protect water pump pulley edge from being scratched or damaged, stick a piece of shop cloth (1) at the position indicated in the figure using adhesive tape before continuing to remove the bolt.

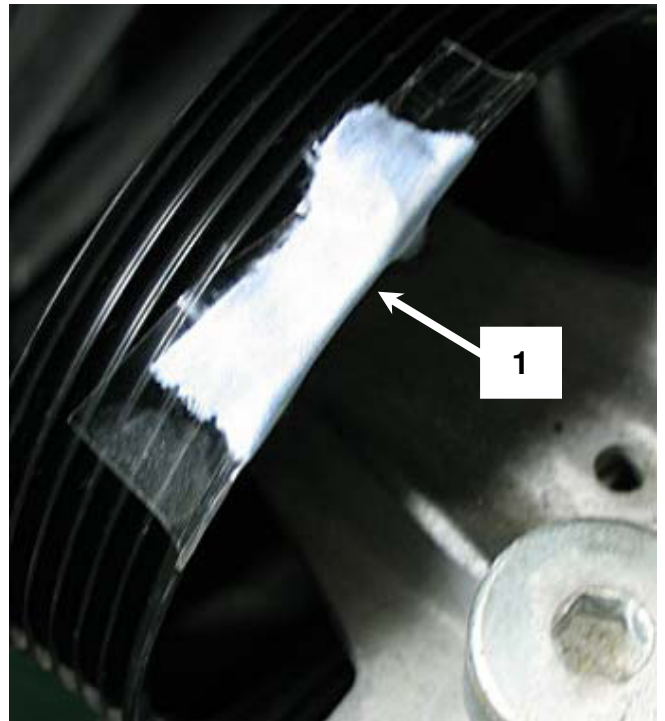

7. Rotate the water pump pulley so the adhered shop cloth is located in line behind the bolt (1).
8. Loosen the bolt (2) using an open-end wrench.
9. Remove the tensioner body along with the upper bolt (the bolt cannot be removed with the tensioner body still in place).

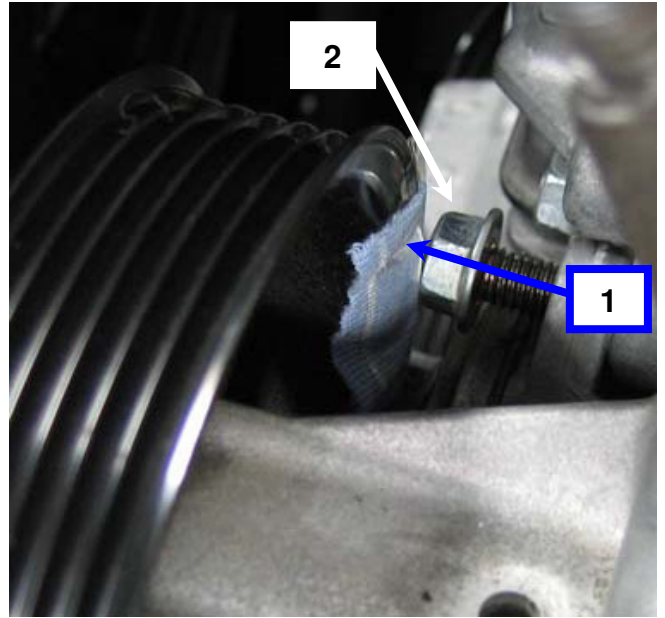

Installation Procedure

10. Place the NEW tensioner assembly (countermeasure part) in a soft jawed vise (1) and remove tensioner pulley bolt (2).

Note: Take care not to fasten the tensioner too tightly in the vise. Excessive tightening of the vise jaws will deform the tensioner.

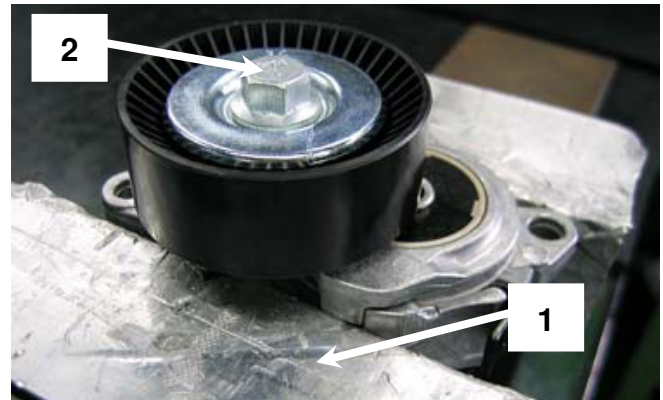

11. Disassemble the NEW tensioner assembly to separate the tensioner body (1), the pulley (2), the pulley shield (3) and the tensioner pulley bolt (4).

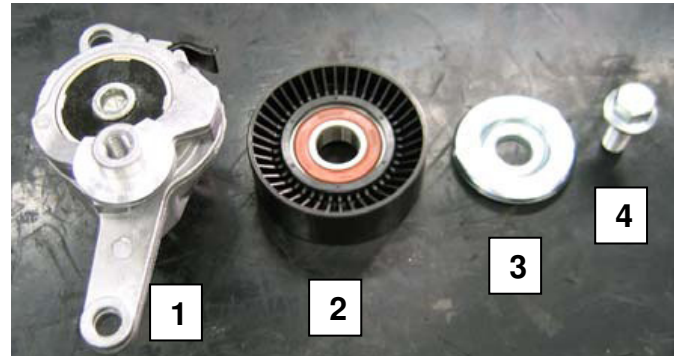

12. Discard the original upper bolt that secured the tensioner body, and install the new hexagon head bolt with washer (countermeasure parts).



13. Install the tensioner body (1) to the cylinder block and tighten the lower side bolt (2) of tensioner body lightly.
14. Install the NEW hexagon bolt (3) and washer (countermeasure parts) at the upper side of the tensioner body.
15. Using the hexagon bit socket and torque wrench, tighten upper side bolt (3) of tensioner body to specified torque.
16. Tighten lower side bolt (2) of tensioner body to specified torque.

Tightening torque
Tensioner body bolt (a): 18.5 lbf-ft (25 N·m, 2.5 kgf-m)

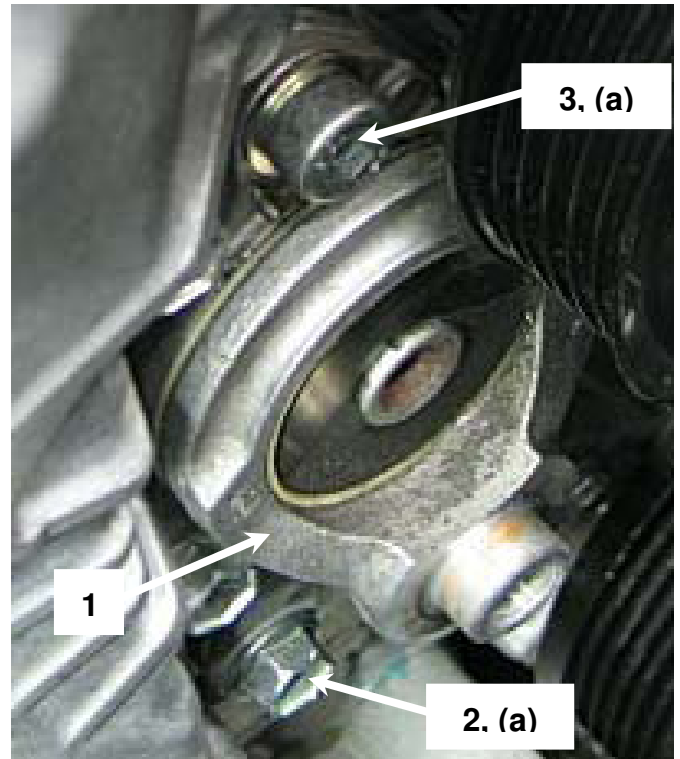

17. Install tensioner pulley (1), pulley shield (2) and tensioner pulley bolt (3).

Note: Off-centering of the pulley shield hinders tightening of pulley bolt. Tighten pulley bolt while centering pulley shield.

18. Tighten the tensioner pulley bolt (3) to the specified torque.

Note: When tightening the tensioner pulley bolt, turn the tensioner up to the swing end, and then apply specified torque.

Tightening torque
Tensioner body bolt (b): 33.5 lbf-ft (45 N·m, 4.5 kgf-m)

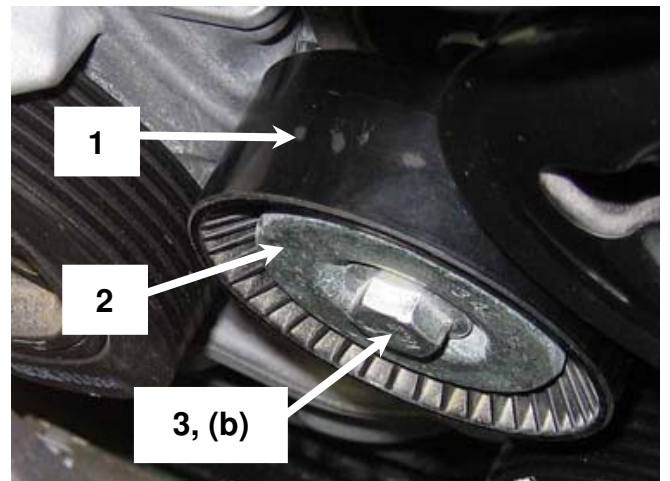

19. Remove the portion of shop towel from the water pump pulley.

Note: Check the water pump pulley for any abrasion caused by replacement of the tensioner and touch up as necessary.

20. While keeping the tensioner (1) in the clockwise turned position with wrench (3), install generator drive belt (2) and then gently release the tensioner.

Note: Do not turn the tensioner with a torque greater than 43.5 lbf-ft (59 N•m, 6.0 kgf-m). Over turning may cause damage to the tensioner.

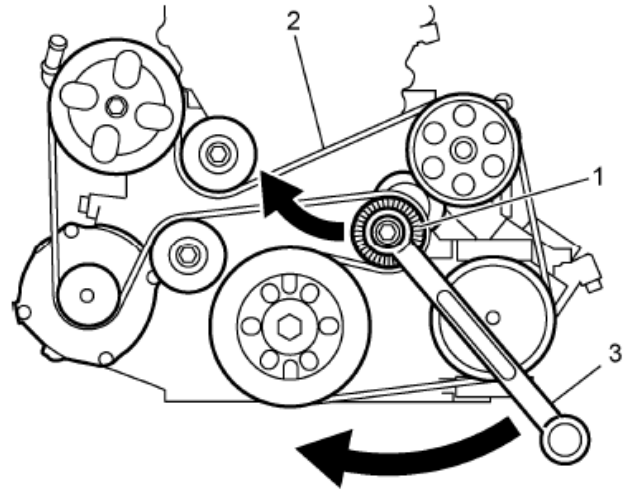

21. Make sure alternator drive belt is installed properly in the grooves of each pulley.
22. Start the engine and check that there is no abnormal noise, and the belt remains positioned in pulley grooves without any failure.
23. Apply the proper campaign label to the upper radiator support in an area where it will be easily seen and identified, and record your Dealer Code in the white portion of the label.

