



**STRICK TRAILERS, LLC**

225 Lincoln Highway

Fairless Hills

Pennsylvania, USA

19030.0009

215.949.3600

March 2, 2011

■  
Associate Administrator for Enforcement  
National Highway Traffic Safety Administration  
Attention: Kelly Schuler and Delia Lopez  
1200 New Jersey Street, SE  
Washington, DC 20590

Re: Arvin Meritor Campaign ID Number: C11AB  
NHTSA Campaign ID Number: 10E-058

Dear Administrator:

We have been advised by ArvinMeritor of changes to the suspect population axle serial numbers and revision to the inspection instruction previously provided regarding the above-referenced recall campaign. In accordance with the requirements of the National Traffic and Motor Vehicle Safety Act regarding the above-referenced recall campaign, enclosed is our draft notification letter advising of these changes.

Upon receipt of approval by you, we will send out the notification letter. If there are any questions, I can be reached at:

Phone: 215-949-4780

Fax: 215-949-4775

Email: [ddaley@diamatrix.net](mailto:ddaley@diamatrix.net)

Thank you.

Sincerely,

Donna J. Daley  
Legal Assistant

Enc.

VIA FEDEX



**SAFETY RECALL – ARVINMERITOR TL SERIES TRAILER AXLES**

**STRICK TRAILERS, LLC**

*225 Lincoln Highway*

*Fairless Hills*

*Pennsylvania, USA*

*19030.0009*

*215.949.3600*



March 2, 2011

Innovative Transportation Services  
Attention: Mr. Bill Scullin  
4100 North Point Industrial Boulevard  
Charlotte, North Carolina 28216

Dear Mr. Scullin:

As you know, notice was sent to you in accordance with the requirements of the National Traffic and Motor Vehicle Safety Act on or about February 14, 2011 relating to a defect in certain vehicles equipped with ArvinMeritor TL Series trailer axles. We have now been notified by ArvinMeritor that the serial number (suspect population) list and inspection instruction TP-0860 have been revised. Enclosed is a copy of the notification containing the suspect population axle serial numbers and a revised inspection instruction.

Very truly yours,

Jim Jackson

dd  
Enc.

**CERTIFIED MAIL – R.R.R.**

INNOVATIVE TRANSPORTATION

Customer: INNOVATIVE TRANSPORTATION SERVICES

4100 NORTH POINTE INDUSTRIAL BLVD.

CHARLOTTE, NC 28216

ATT: BILL SCULLIN

SERIAL NBR	MANUFACTURING DATE	DELIVERY DATE	REPAIRED DATE	SALES ORDER
1S12E95377E516834	9/22/06	10/26/06		09M8478
1S12E95397E516835	9/22/06	10/16/06		"
1S12E95307E516836	9/22/06	10/2/06		"
1S12E95327E516837	9/25/06	10/28/06		"
1S12E95347E516838	9/25/06	11/9/06		"
1S12E95367E516839	9/25/06	11/15/06		"
1S12E95327E516840	9/25/06	11/10/06		"
1S12E95347E516841	9/25/06	11/10/06		"
1S12E95367E516842	9/25/06	10/6/06		"
1S12E95387E516843	9/25/06	12/28/06		"
1S12E953X7E516844	9/26/06	10/7/06		"
1S12E95317E516845	9/26/06	11/15/06		"
1S12E95318E516846	1/18/07	2/17/07		"
1S12E95338E516847	1/18/07	2/19/07		"
1S12E95358E516848	1/18/07	1/26/07		"
1S12E95378E516849	1/18/07	11/10/06		"
1S12E95338E516850	1/18/07	1/26/07		"
1S12E95358E516851	1/22/07	2/20/07		"
1S12E95378E516852	1/22/07	2/20/07		"
1S12E95398E516853	1/22/07	2/9/07		"
1S12E95308E516854	1/22/07	2/21/07		"
1S12E95328E516855	1/22/07	3/1/07		"
1S12E95348E516856	1/22/07	3/27/07		"
1S12E95368E516857	1/22/07	3/29/07		09M8478

1S12E95378E520576	7/16/07	10/2/07		09M8676
1S12E95398E520577	7/16/07	9/10/07		"
1S12E95308E520578	7/16/07	8/6/07		"
1S12E95328E520579	7/16/07	7/27/07		"
1S12E95398E520580	7/16/07	7/23/07		"
1S12E95308E520581	7/16/07	7/27/07		"
1S12E95328E520582	7/16/07	9/10/07		"
1S12E95348E520583	7/16/07	7/23/07		"
1S12E95368E520584	7/17/07	8/21/07		"
1S12E95388E520585	7/17/07	8/8/07		"
1S12E953X8E520586	7/17/07	11/19/07		"
1S12E95318E520587	9/6/07	12/3/07		"
1S12E95338E520588	9/6/07	10/8/07		"
1S12E95358E520589	9/6/07	11/20/07		"
1S12E95318E520590	9/6/07	10/8/07		"
1S12E95338E520591	9/6/07	9/26/07		"

INNOVATIVE TRANSPORTATION

1S12E95358E520592	9/6/07	9/24/07		"
1S12E95378E520593	9/6/07	9/24/07		"
1S12E95398E520594	9/7/07	10/24/07		"
1S12E95308E520595	9/7/07	9/17/07		"
1S12E95328E520596	10/8/07	10/16/07		"
1S12E95348E520597	10/8/07	10/17/07		"
1S12E95368E520598	10/8/07	10/17/07		"
1S12E95388E520599	10/8/07	11/20/07		"
1S12E95308E520600	10/8/07	11/19/07		"
1S12E95328E520601	10/8/07	11/20/07		"
1S12E95348E520602	10/9/07	11/19/07		"
1S12E95368E520603	10/9/07	11/7/07		"
1S12E95388E520604	10/9/07	12/5/07		09M8676

1S12E95389E522483	3/10/08	7/7/08		09M8825
1S12E953X9E522484	3/10/08	5/21/08		"
1S12E95319E522485	3/10/08	6/2/08		"
1S12E95339E522486	3/10/08	5/6/08		"
1S12E95359E522487	3/10/08	4/21/08		"
1S12E95379E522488	3/10/08	4/14/08		"
1S12E95399E522489	3/11/08	4/7/08		"
1S12E95359E522490	3/11/08	4/4/08		"
1S12E95379E522491	3/11/08	3/31/08		"
1S12E95399E522492	3/11/08	3/17/08		"
1S12E95309E522493	3/11/08	3/17/08		"
1S12E95329E522494	3/11/08	3/17/08		"
1S12E95349E522495	3/11/08	3/17/08		09M8825

1S12E953X7E512731	3/8/06	5/15/06		09M8342A
1S12E95317E512732	3/8/06	3/30/06		"
1S12E95337E512733	3/9/06	4/3/06		"
1S12E95357E512734	3/9/06	4/12/06		"
1S12E95377E512735	3/9/06	4/22/06		"
1S12E95397E512736	3/9/06	5/18/06		"
1S12E95307E512737	3/9/06	3/31/06		"
1S12E95327E512738	3/9/06	4/13/06		09M8342A

2/22/2011

Jim Jackson  
Strick Corporation  
301 N. Polk Street  
Monroe, IN 46772

NOTICE: Revised Defect Information Notice – concerning Spindle Nuts and Stake Washer on certain ArvinMeritor TL Series trailer axles.

ArvinMeritor File: C11AB

NHTSA File: 10E-058

Dear ArvinMeritor Customer:

This is a revised notification for the subject campaign and contains revised serial number (suspect population) list and a revised inspection instruction (TP0680). Please disregard previous notification for the subject ArvinMeritor campaign number C11AB (NHTSA file # 10E-058). This notice is sent to you in accordance with the requirements of the National Traffic and Motor Vehicle Safety Act.

ArvinMeritor has decided that a defect which relates to motor vehicle safety exists in certain ArvinMeritor Trailer axle's wheel end systems. The affected motor vehicle equipment is ArvinMeritor TL Series trailer axles assembled at ArvinMeritor's Frankfort, Kentucky facility. The axles were shipped between April 2005 and July 2008.

#### Description of Defect

ArvinMeritor has received field reports of low torque on the spindle nut on ArvinMeritor TL Series installed in van trailers where the stake washer for the nut is staked in a single location as opposed to multiple locations. Low and or no torque on the nut can result in excessive end-play in the wheel-end system and could progress to a wheel separation which could result in a crash.

#### NHTSA Notification & Safety Recall Obligations

According to our records, affected units were shipped to your company. If those units were installed as original equipment on vehicles manufactured at your facility, and you agree that they contain a safety defect, your company must notify the National Highway Traffic Safety Administration (NHTSA) within 5 business days and conduct a safety recall of those vehicles. It is critical that the NHTSA guidelines are followed in a timely manner and that your customers are notified to conduct the remedy described below.

**IMPORTANT:** Some of the affected vehicles may still be in your inventory. Federal law requires you to complete the recall service on these vehicles before delivery. ArvinMeritor will provide replacement or repair for these units prior to delivery to your customers.

You must also submit your draft version of your dealer and customer notices to NHTSA for approval at least 5 days prior to mailing such notification to dealers and owners of potentially affected axles. You may contact NHTSA with questions by sending an email to [rmd.odl@dot.gov](mailto:rmd.odl@dot.gov).

**IMPORTANT:** Dealer notification by Certified Mail is required by Federal law for all safety recalls. Responsible dealership personnel should be instructed to sign for this Certified Mail without hesitation as it contains urgent safety recall information. Notifications to owners of potentially affected vehicles are by first class mail. Please be advised that the outside of each envelope containing an owner notification letter must be marked "SAFETY RECALL NOTICE" all in uppercase letters, either in boldface or underlined, and in type that is larger than that used in the address section. A sample of the envelope must be submitted to NHTSA for approval at least 5 business days before mailing to owners.

# ArvinMeritor™

## Recommended Action

ArvinMeritor recommends that owners of trailers originally equipped with ArvinMeritor TL axles be contacted immediately and asked to inspect the wheel ends per Technical Bulletin TP0860. This bulletin will update the staking to three position and increase the nut torque from ~550lb/ft to 850lb/ft.

Affected trailers should be inspected as soon as possible by an authorized repair facility. This program will be managed by ArvinMeritor, and will be at no expense to vehicle owners.

## Identification of Affected Parts

The suspect population information containing the axle serial numbers is attached with this notification. ArvinMeritor is continuing to research shipment records. You may receive a separate notice for additional axle serial numbers from ArvinMeritor.

Vehicle manufacturers are requested to provide VIN information and In-Service Dates for the corresponding axle serial numbers for tracking field actions. The requested information is to be forwarded to:

Jeremy Tertzakian  
[Jeremy.Tertzakian@ArvinMeritor.com](mailto:Jeremy.Tertzakian@ArvinMeritor.com)  
OnTrac Technical Manager – Troy, MI  
Ph 248.273.4641 Fax 248-435-5580

## Availability of Replacement Parts and Service Instructions

Replacement parts are currently available and if needed will be provided by ArvinMeritor at no cost. Vehicle manufacturers' (OEM) or repair facilities should obtain replacement parts by contacting ArvinMeritor's OnTrac Performance Plus Call Center using any of the below methods.

**Contact:** OnTrac Performance Plus Call Center, follow the menu system for the appropriate language and select option number 5

**Phone:** 1-866-668-7221

**Fax:** 248-435-5580

**Email:** [ontrac@ArvinMeritor.com](mailto:ontrac@ArvinMeritor.com)

## Parts, Labor and Handling Allowance

The following are the details of allowances relating to parts, labor and handling available to vehicle manufacturers' (OEM):

- ArvinMeritor will reimburse at the repair facility standard warranty repair rate of up to 1.5 hours for vehicle inspection and will reimburse up to an additional 1 hours per wheel-end if hub replacement is required.

## Claims for Credit

ArvinMeritor will accept warranty claims for inspection associated with this notice directly from the vehicle manufacturers (OEM). In order to receive proper credit, such warranty claims must contain the following information at the time of submission:

- Reference to ArvinMeritor Campaign ID Number : C11AB
- Reference to NHTSA Campaign ID Number : 10E-058
- Reference to the vehicle manufacturer's campaign number (optional)
- 17-digit vehicle identification number (VIN)

# ArvinMeritor™

- Axle model and serial number
- Vehicle owner's name, address, and telephone number
- Vehicle in-service date
- Vehicle inspection date
- Vehicle mileage at the time of repair (if available)
- Repair facility work order number
- Repairing facility name, address, and telephone number
- Total labor hours required performing the work, not to exceed agreed amount
- Repair facilities hourly rate

Failure to provide complete information will delay processing of the claim.

Questions relating to warranty claims, replacement parts delivery and parts disposition can be addressed to the ArvinMeritor OnTrac Performance Plus Call Center using any of the below methods.

**Contact:** OnTrac Performance Plus Call Center, follow the menu system for the appropriate language and select option number 5

**Phone:** 1-866-668-7221

**Fax:** 248-435-5580

**Email:** [ontrac@ArvinMeritor.com](mailto:ontrac@ArvinMeritor.com)

## Communication

If you conclude that ArvinMeritor has not enabled you to remedy this condition in a reasonable time, you may submit a complaint to the:

Administrator  
National Highway Traffic Safety Administration  
1200 New Jersey, S.E.  
Washington, D.C. 20590

- or -

Call the toll free Vehicle Safety Hotline: 1-888-327-4236; (TTY: 800-424-9153  
or go to <http://www.safercar.gov>

We regret any inconvenience that this situation may cause. ArvinMeritor wants to assure you that we are concerned for customer safety and your continued satisfaction with our products.

Sincerely,

ArvinMeritor

Jeremy Tertzakian  
OnTrac Technical Manager

Attachments:







## Procedures and Intervals to Inspect the Wheel Ends and Tighten the Spindle Nuts on Meritor TL Series Trailer Axles with Unitized Wheel Ends

### Hazard Alert Messages

Read and observe all Warning and Caution hazard alert messages in this publication. They provide information that can help prevent serious personal injury, damage to components, or both.

#### **WARNING**

To prevent serious eye injury, always wear safe eye protection when you perform vehicle maintenance or service.

Park the vehicle on a level surface. Block the wheels to prevent the vehicle from moving. Support the vehicle with safety stands. Do not work under a vehicle supported only by jacks. Jacks can slip and fall over. Serious personal injury and damage to components can result.

#### **ASBESTOS AND NON-ASBESTOS FIBERS WARNING**

Some brake linings contain asbestos fibers, a cancer and lung disease hazard. Some brake linings contain non-asbestos fibers, whose long-term effects to health are unknown. You must use caution when you handle both asbestos and non-asbestos materials.

#### **CAUTION**

A unitized hub is permanently sealed and lubricated as an assembly. Do not attempt to remove the hub bearings, seals or lubricant. You cannot service or reinstall these components back into a unitized hub. Damage to components can result. Removal of the long-life bearings, seals or lubricants from the Meritor TL model unitized hub will void the warranty.

### How to Obtain Additional Maintenance and Warranty Information for TL Series Trailer Axles with Unitized Wheel Ends

Refer to Maintenance Manual MM-0420, Trailer Axles with Unitized Wheel Ends; and Maintenance Manual 14, Trailer Axles. For warranty information, refer to publication SP-95155, Commercial Vehicle Systems Warranty. To access these publications, visit Literature on Demand at [arvinmeritor.com](http://arvinmeritor.com).

### How to Obtain Parts

Call ArvinMeritor's Commercial Vehicle Aftermarket at 888-725-9355. To obtain Snap-On® tool, part number TTFM932, contact [www.snapon.com](http://www.snapon.com).

### Inspection and Maintenance Intervals by Service Applications

The following is intended as a general guideline for scheduled wheel-end inspections. Note that the recommended frequency of these inspections depends on such service factors as the environment, mileage, speed and loading.

## Inspection Intervals

Application	Description	Intervals
Linehaul	High mileage, over 60,000 miles per year. On-road service; operated on concrete, asphalt, maintained gravel, crushed rock, hard/packed dirt, or other similar surfaces; moderate grades. More than 30 miles between stopping and starting.	Every 100,000 miles (160 000 km) or 12 months, whichever comes first. Some Examples: Haulers (auto, bulk, grain, etc.), general freight, tanker.
General Service	Lower mileage, usually less than 60,000 miles per year. Generally on-road service, with usually less than 10% off-road. Usually 3 miles between stopping and starting.	Every 100,000 miles (160 000 km) or 12 months, whichever comes first. Some Examples: Intermodal chassis service, auto hauler, flatbed.
Heavy Service	Moderate mileage, usually less than 60,000 miles per year. On- and off-road service, with usually 10% or more off-road. Moderate to frequent stops and starts, usually up to 10 stops per mile.	At tire replacement. At brake reline. Every 30,000 miles (48 270 km) or 2 months, whichever comes first. Some Examples: Flatbed trailer hauler, log hauling, equipment hauling.

## Scheduled Maintenance

Inspect the wheel end for smooth rotation, movement and seal leaks at each brake reline or regularly scheduled preventive maintenance.

## ABS Warning Signal

Inspect the wheel end for smooth rotation, movement and bearing end play if a driver reports that an ABS light has been coming on and ABS diagnostics indicates excessive sensor gap.

## Basic Hub Inspection

Perform the following procedure for each wheel end on the trailer.

1. Wear safe eye protection.
2. Park the trailer on a level surface. Use a jack to raise the trailer until all of the trailer tires are off the ground. Place safety stands under the trailer frame or axles. Do not use a jack to support the trailer.
3. Rotate the wheel assembly to check for signs of unusual resistance or roughness from the bearing. Listen for a low-pitched grinding sound as you rotate the assembly. Use care to determine whether sounds heard are coming from the bearing and not from the brake components or dust cover.
  - If unusual resistance or noise is detected: Replace the hub. Refer to Replace the Hub for correct procedures.

4. Grasp the tire and wheel-end assembly at the 12 and six o'clock positions. Check for vertical and horizontal movement. With your hands, apply approximately 50 lb (23 kg) of force to the assembly. You should not feel or see any looseness or movement. Figure 1.

- If you feel or see movement at the tire circumference: Proceed to the Detailed Hub Inspection procedure.
- If no movement is detected: Proceed to the Quick Clamp Load and Inspection procedure.

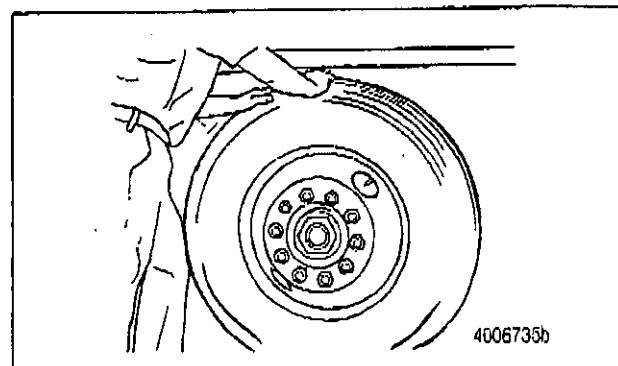

Figure 1

## Quick Clamp Load and Inspection Procedure

1. Remove the hubcap.
2. Use a screwdriver to release the stakes from the stake washer flange. Figure 2.

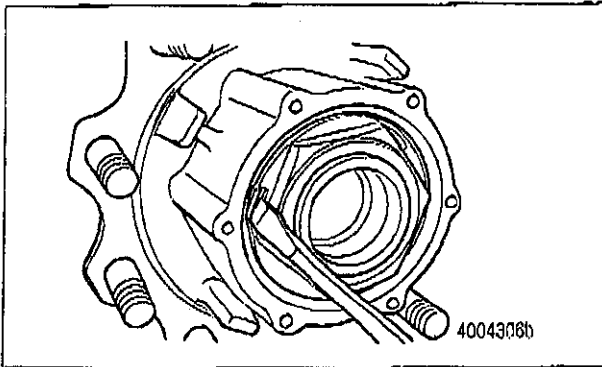

Figure 2

3. Remove spindle nut and stake washer.
4. Install a new stake washer (part number AM21225514).
5. Install new spindle end nut (part number AM21225405) onto the spindle.

### **⚠ WARNING**

You must rotate the hub **COUNTERCLOCKWISE** while you tighten the spindle nut to the specified torque. If you do not rotate the hub during the tightening procedure, the spindle nut can loosen, and the bearing may not seat correctly, which can cause the wheel to separate from the vehicle during operation. Serious personal injury and damage to components can result.

**NOTE:** Disregard the torque values embossed into the outer face of the spindle nut. Tighten the nut to the values specified in Step 6 below.

6. Tighten the spindle end-nut to **810-850 lb-ft (1100-1150 N·m)** while rotating the wheel and hub **COUNTERCLOCKWISE**. Do not back off the nut after tightening. Re-clamp and mark the spindle nut position relative to the spindle. For future service, use the marks to show if the nut has rotated. **ⓘ**
7. Rotate the wheel assembly to check for signs of unusual resistance or roughness from the bearing. Listen for a low-pitched grinding sound as you rotate the assembly. Use care to determine whether sounds heard are coming from the bearing and not from the brake components or dust cover.
  - If unusual resistance or noise is detected: Replace the hub. Refer to Replace the Hub for correct procedures.

8. Grasp the tire and wheel-end assembly at the 12 and six o'clock positions. Check for vertical and horizontal movement. With your hands, apply approximately 50 lb (23 kg) of force to the assembly. You should not feel or see any looseness or movement. Figure 1.

- If you feel or see movement at the tire circumference: Proceed the Deflated Hub Inspection procedure.

**NOTE:** You must stake the stake washer to the spindle nut in **three** positions.

9. Use a hammer and staking tool (Figure 13) to stake the stake washer to the spindle nut in **three** positions. Bend the washer to the stake profile as shown. Figure 3 and Figure 4.

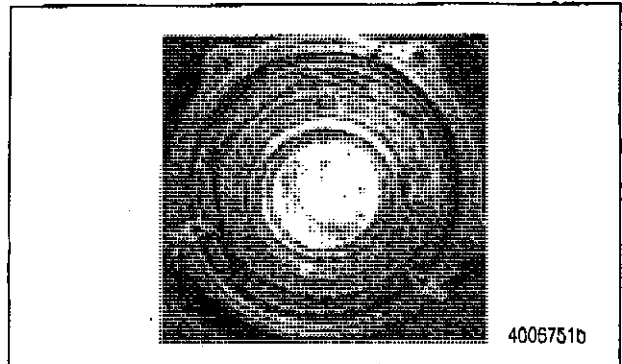

Figure 3

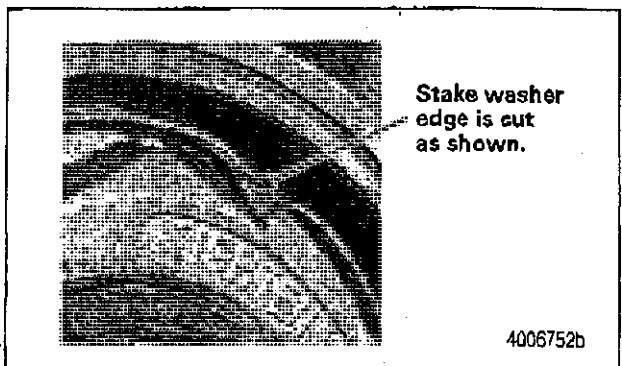

Figure 4

10. Clean the hub end surface and hubcap flange prior to reassembly of the hubcap.
11. Install the hubcap with a new gasket (part number 2208-B-1172). Install new hubcap capscrews. Tighten the hubcap capscrews in a crisscross pattern to **15-30 lb-ft (20-40 N·m)**. **ⓘ**

## Detailed Hub Inspection

1. Follow the wheel manufacturer's instructions to remove the tire, wheel assembly and brake drum.
2. If necessary, remove the hubcap.
  - If this is not the first inspection: Check the mark on the spindle nut and spindle to see if the nut has moved.
  - If the mark has moved, then the nut was not previously tightened enough: Clean the threads.
3. Attach the magnetic base of the dial indicator to the spindle. Touch the dial indicator stem to the hubcap mounting surface. Figure 5.

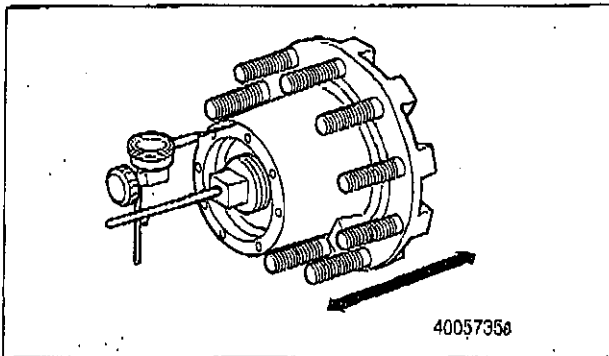

Figure 5

4. Set the dial indicator to ZERO. Do not rotate the wheel end. Place your hands at the nine and three o'clock positions.
5. Push the unitized wheel end straight IN. Note the reading. Then pull the wheel end straight OUT. Note the reading.
  - If the total movement of the dial indicator is less than 0.003-inch (0.08 mm): Follow instructions 2 through 11 in the Quick Clamp and Load Inspection procedure.
  - If the total movement is 0.003-inch (0.08 mm) or greater: Proceed to the Thread Inspection procedure.

## Thread Inspection

Perform the following procedure for each wheel end on the trailer with end play at the hub greater than 0.003-inch (0.08 mm) or wheel movement greater than 0.04-inch (1 mm).

1. Use a screwdriver to release the stakes from the stake washer flange. Figure 6.

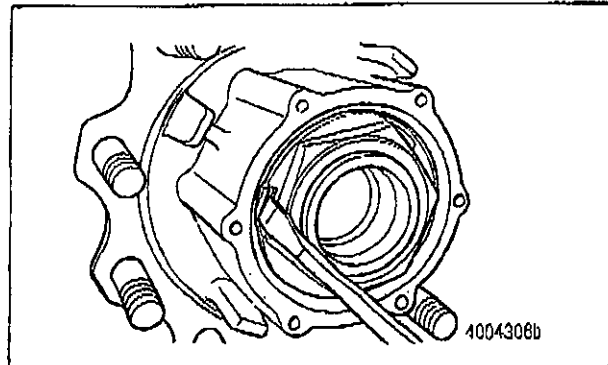

Figure 6

2. Remove the spindle nut from the spindle end. Figure 7.

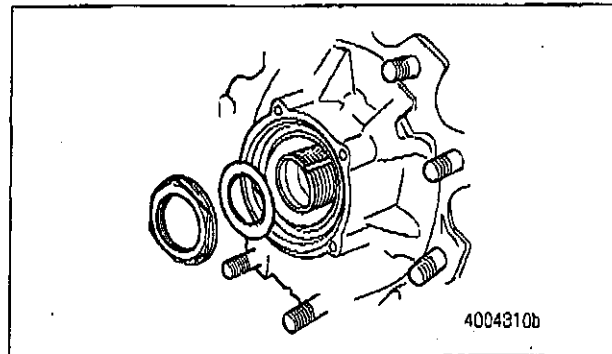

Figure 7

3. Check the spindle threads. Figure 8.
  - If the threads are not free running, and a limit of two threads are damaged: Repair the threads with a thread file (Snap-On® tool, part number TTFM932, or equivalent).
  - If there are more than two threads damaged: Replace the axle beam. Refer to Maintenance Manual 14 for the procedures.

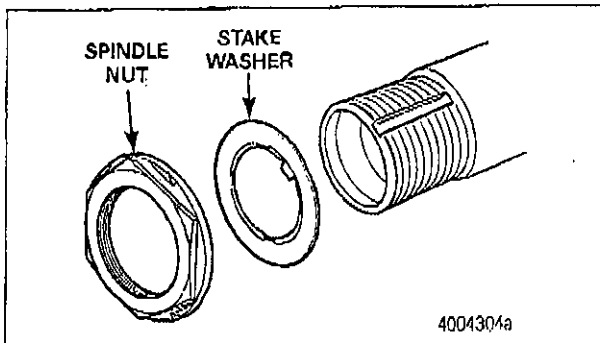

Figure 8

4. Clean the spindle threads and nut threads.
5. Install a new stake washer (part number AM21225514) onto the spindle.
6. Install the spindle end nut (part number AM21225405) onto the spindle.

**⚠ WARNING**

You must rotate the hub **COUNTERCLOCKWISE** while you tighten the spindle nut to the specified torque. If you do not rotate the hub during the tightening procedure, the spindle nut can loosen, and the bearing may not seat correctly, which can cause the wheel to separate from the vehicle during operation. Serious personal injury and damage to components can result.

**NOTE:** Disregard the torque values embossed into the outer face of the spindle nut. Tighten the nut to the values specified in Step 7 below.

7. Tighten the spindle end nut to 810-850 lb-ft (1100-1150 N·m) while rotating the wheel and hub in a **COUNTERCLOCKWISE** direction. Do not back off the nut after tightening. Mark the nut location relative to the spindle. Figure 9. **ⓘ**

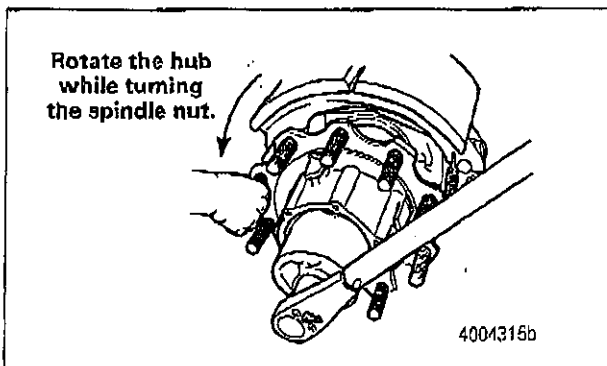

Figure 9

8. Check for wheel-end movement to ensure the wheel end rotates freely as described in the inspection procedure. Verify end play is less than 0.003-inch (0.08 mm) by following Steps 3, 4 and 5 of the Detailed Hub Inspection procedure.
  - If end play is greater than 0.003-inch (0.08 mm): Replace the hub. Refer to Replace the Hub for correct procedures.

**NOTE:** You must stake the stake washer to the spindle nut in three positions.

9. Use a hammer and staking tool (Figure 13) to stake the stake washer to the spindle nut in three positions. Figure 10 and Figure 11.

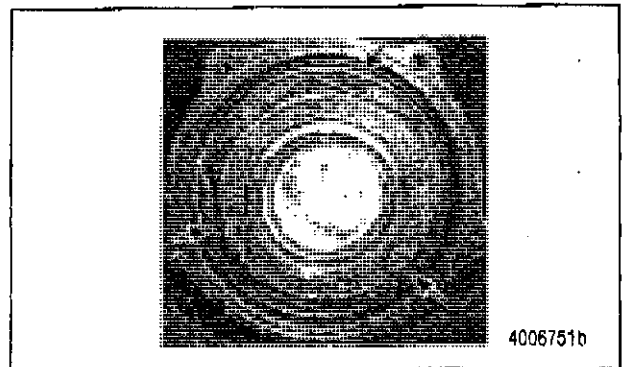

Figure 10

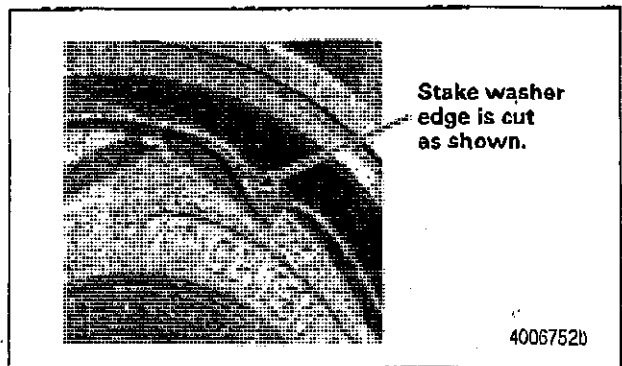

Figure 11

10. Clean the hub end surface and hubcap flange prior to reassembly of the hubcap.
11. Install the hubcap with a new gasket (part number 2208-B-1172). Install new hubcap capscrews. Tighten the hubcap capscrews in a crisscross pattern to 15-30 lb-ft (20-40 N·m). **ⓘ**

## Replace the Hub

Refer to Maintenance Manual MM-0420 for correct procedures.

Contact ArvinMeritor's Commercial Vehicle Aftermarket at 888-725-9355 for the correct hub replacement part number.

**NOTE:** Previous versions of TL hubs may or may not have an O-ring on the inboard side of the hub. All replacement hubs will include an O-ring. This O-ring must be installed with the replacement hub regardless of previous hub arrangement.

1. Ensure the O-ring (part number AM1 205Q2747) between the bearing cartridge and the spindle shoulder is inserted into the groove and in place when the hub is installed. Figure 12.

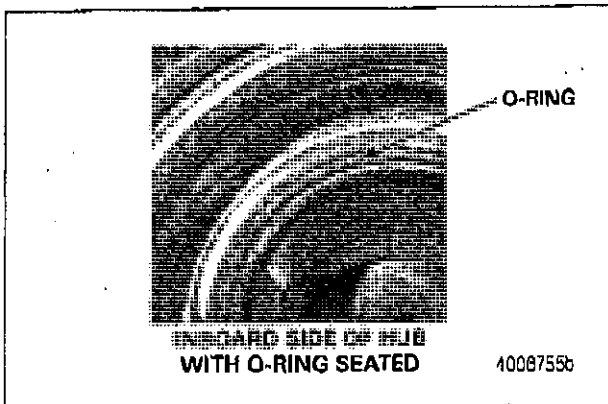

Figure 12

2. Check the spindle to ensure there is NOT an extra O-ring.

## Staking Service Tool

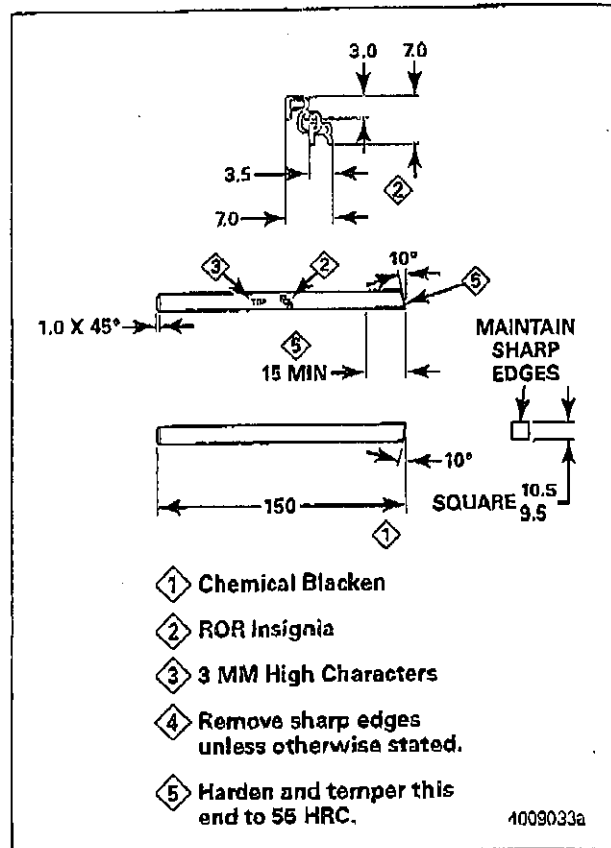

Figure 13

## ArvinMeritor™

Meritor Heavy Vehicle Systems, LLC  
2135 West Maple Road  
Troy, MI 48064 USA  
866-OnTrac1 (668-7221)  
arvinmeritor.com

Information contained in this publication was in effect at the time the publication was approved for printing and is subject to change without notice or liability. Meritor Heavy Vehicle Systems, LLC, reserves the right to revise the information presented or to discontinue the production of parts described at any time.

Copyright 2011  
ArvinMeritor, Inc.  
All Rights Reserved

Printed in USA

TP-0860  
Revised 02-11  
(16579)