

SAFETY RECALL NOTICE



Bombardier Recreational Products Inc.

565 de la Montagne Street
Valcourt, Québec, Canada J0E 2L0
T 450.532.2211 F 450.532.5133

www.brp.com

Date: February 9th, 2011

Re: Reverse Actuator – Can Am™ Spyder™ RT SM5 roadster

Dear Can-Am Roadster Dealer/Distributor,

This notice is being sent to you in accordance with the requirements of the National Traffic and Motor Vehicle Safety Act, the Canada Motor Vehicle Safety Act and other applicable laws. Bombardier Recreational Products Inc. and BRP US Inc. (“BRP”) have decided that a defect which relates to motor vehicle safety exists on certain roadster models and are conducting a voluntary safety recall as specified in the attached Safety Campaign Bulletin.

What is the potential problem?

While downshifting, it may be possible to inadvertently engage reverse without depressing the reverse button, due to a defective reverse actuator cable. If this happens while vehicle is moving forward, the rear wheel could lock and the engine could stall. If this happens while vehicle is stopped or moving forward, vehicle could back up. This condition may increase the risk of a crash possibly resulting in injury or death.

What will BRP do?

BRP is sending a Safety Recall letter to all known registered owners of the involved vehicles. This letter urges that the owners immediately contact their authorized BRP Can-Am Spyder Roadster dealer in order to have the vehicle inspected and repaired if necessary. Also, BRP is posting this notice and attached Safety Campaign Bulletin on its BOSSWeb dealer web site (www.bossweb.com) and on its public web site (www.can-am.brp.com).

The solution is to validate proper operation of the reverse actuator and if defective, replace the reverse actuator assembly.

What should you do?

1. Do not sell or deliver any involved vehicle that you have in stock as federal law requires you to complete the recall service on these vehicles before delivery.
2. Contact all of your customers who have purchased an affected vehicle. You must inform them about the foregoing and must request them to make an appointment to get their vehicle repaired.
3. Inform them about important precautions to be taken until this recall has been performed:
Be aware that it is possible that you inadvertently engage reverse while downshifting. Stay alert and make sure, while downshifting, to check that the gearbox position in the multifunction gauge does not show "R" before releasing the clutch lever. Be particularly careful when releasing the clutch lever after downshifting into 1st gear. Pass on this information to any other driver of your vehicle.
4. Follow all instructions provided in the attached Safety Campaign Bulletin.

Please note that the National Traffic and Motor Vehicle Safety Act provides that each vehicle which is subject to a recall campaign of this type must be adequately repaired within a reasonable time after the owner has tendered it for repair. Failure to repair within sixty (60) days after tender of a vehicle is prima facie evidence of failure to repair within a reasonable time. The owner may be entitled to an identical or reasonable equivalent vehicle at no charge or to a refund of the purchase price less a reasonable allowance for depreciation.

If you have questions about this notice, please call:

- **In USA and Canada: 1 888 638-5397,**
- **Dealers of other countries (outside Canada and USA) please contact your local distributor or regional office which can be found at www.brp.com call: 1 819 566-3366 (8:00 to 18:00 Eastern time).**

Sincerely,
After-Sales Service Department, Bombardier Recreational Products Inc.

Ski-Doo
Lynx
Sea-Doo
Evinrude
Johnson
Rotax
Can-Am

can-am™



SAFETY CAMPAIGN

ROADSTER WARRANTY Bulletin



⚠ WARNING: All involved customers must be notified, all involved units must be corrected as per instructions herein.

Campaign no.: 2011-0003

February 9th, 2011

Subject: **Spyder™ RT SM5 Reverse Actuator**

No.

2011-3

YEAR	MODEL	MODEL NUMBER	SERIAL NUMBER
2011	Spyder RT SM5	All	See list attached

PROBLEM

While downshifting, it may be possible to inadvertently engage reverse without depressing the reverse button, due to a defective reverse actuator cable.

If this happens while vehicle is moving forward, the rear wheel could lock and the engine could stall. If this happens while vehicle is stopped or moving forward, vehicle could back up.

This condition may increase the risk of a crash possibly resulting in injury or death.

SOLUTION

Validate proper operation of the reverse actuator. If defective, replace the reverse actuator assembly.

PARTS REQUIRED

DESCRIPTION	P/N	QTY
Reverse actuator assembly	(P/N 710 001 954)	1

NOTE: Replace **ONLY IF** part is found defective. Order through regular channels.

PROCEDURE

Reverse Actuator Operation Inspection

Engage reverse with engine running using the normal procedure as follows:

1. Pull in the clutch and select first gear.
2. Press and hold the reverse button.

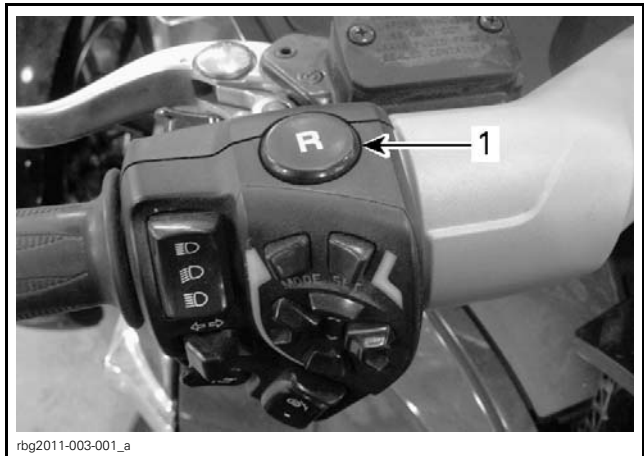

1. Reverse button

3. Press the gearshift lever down to engage reverse.

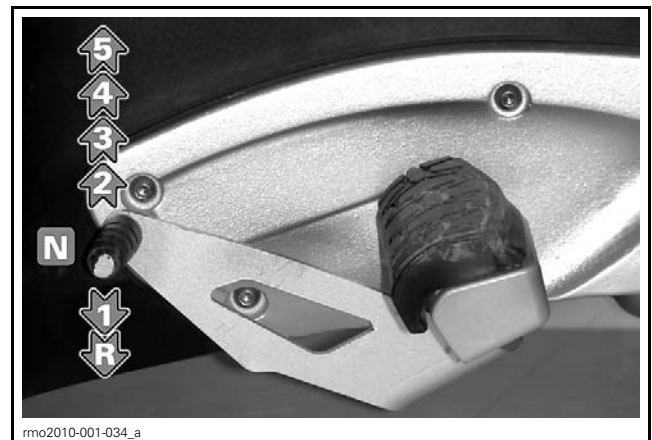

SHIFTER ACTUATION

4. Validate transmission is in reverse via the gear position indicator.
5. Put transmission into first gear.

6. Try to engage reverse gear by pressing the gearshift lever **WITHOUT** activating the reverse button.

NOTICE Do not use excessive force on the shift lever. Damage to the transmission could result.

7. Verify that transmission is still in first gear and has not shifted into reverse by looking at the gear position indicator and by slipping the clutch.



GEAR POSITION INDICATOR ON MULTIFUNCTION GAUGE

8. Shift to neutral.

9. Repeat steps 5, 6, 7 and 8 five times.

If at any time during step 6, the transmission shifts into reverse, replace reverse actuator assembly.

If no problem is detected during the test, no action is required.

Reverse Actuator Replacement

1. On left side, remove the bottom rear side panel and the rear side panel. Refer to *BODY* subsection.
2. Disconnect the reverse actuator connector.

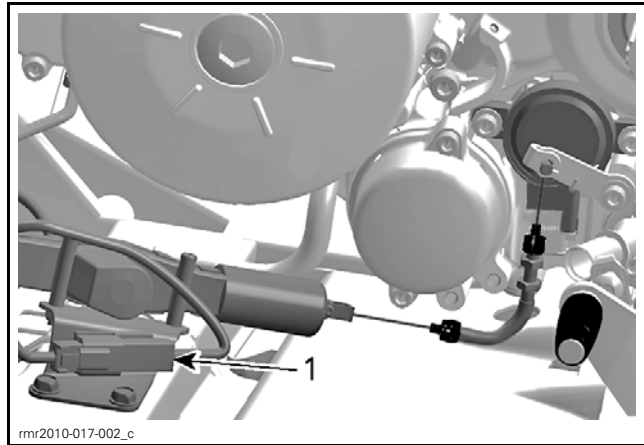

1. Reverse actuator connector

3. Remove reverse actuator mounting screws.

4. Remove cable guide bracket mounting screws.

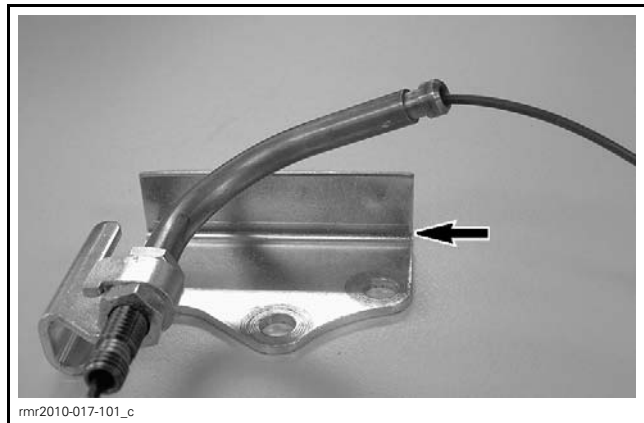

CABLE GUIDE BRACKET

5. Detach actuator cable from control lever.

6. Installation is the reverse of removal however, it is critical to carry out the *REVERSE ACTUATOR CABLE ADJUSTMENT*.

NOTE: Start adjustment procedure before installing the new actuator on the vehicle.

Reverse Actuator Cable Adjustment

1. Lay the cable guide bracket on a workbench and loosen the adjusting nuts.
2. Set the lower adjusting nut against the bottom of the cable guide threads.

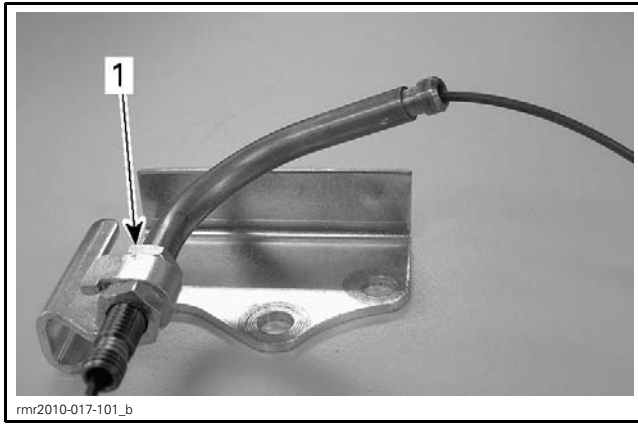

1. Lower nut against bottom of threads.

- Set the distance between the workbench surface and the cable guide center line to $37\text{ mm} \pm 1\text{ mm}$ ($1.46\text{ in} \pm .04\text{ in}$) as shown, then tighten the upper adjustment screw.

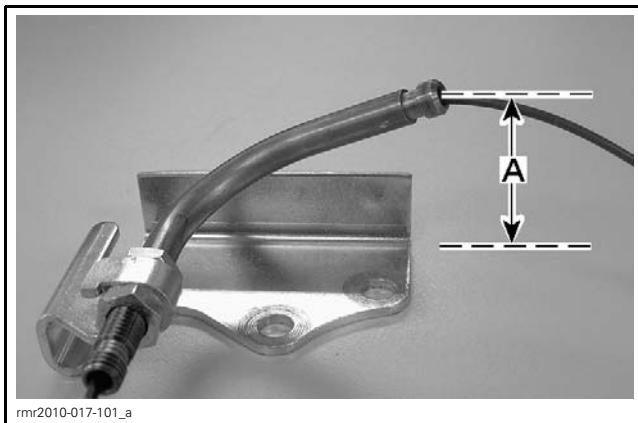

A. $37\text{ mm} \pm 1\text{ mm}$ ($1.46\text{ in} \pm .04\text{ in}$)

- Install the cable guide bracket on the engine.
 - Position actuator on the frame member, then start the rear mounting bolt.
- The actuator center axis must be in line with the cable guide vertically.

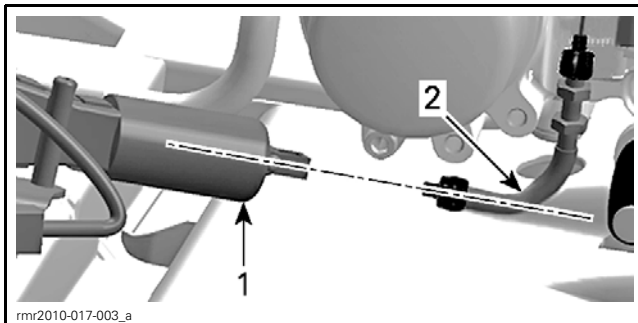

ACTUATOR AND CABLE GUIDE IN LINE

- Actuator
- Cable guide

- Place enough shims (P/N 710 002 024) underneath the actuator mounting plate front hole to obtain alignment.

- Once parts are aligned, start the front mounting screw through the shims.

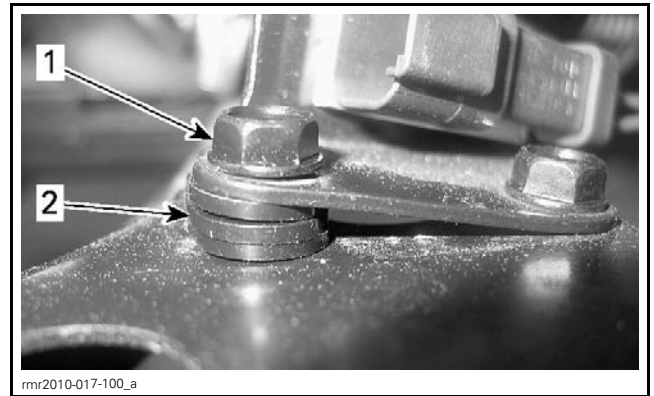

- Front mounting screw
- Shims

- Tighten mounting screws.
- Make sure that there is an axial free play of 2 mm ($1/16\text{ in}$) minimum at actuator rod.

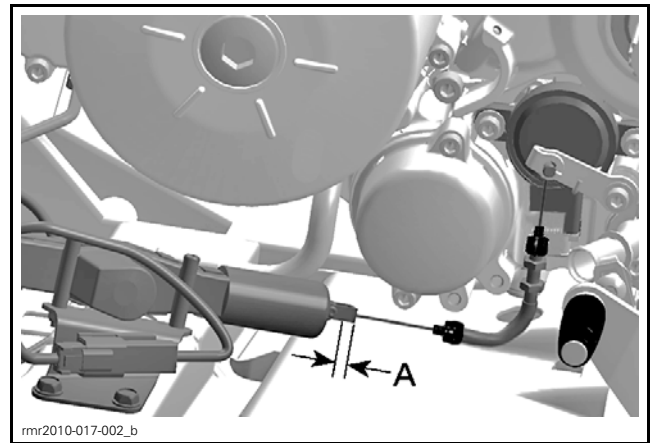

A. Free play at the actuator rod

- Perform inspection procedure at the beginning of this bulletin to validate that gearbox cannot be engaged in reverse without activating reverse button.

WARRANTY

Inspection

When **inspection only** has been performed, submit a warranty claim using the following information:

CAMPAIGN NUMBER	2011-0003
Claim Type	Campaign claim
Action	Inspect
Flat Rate Time	0.3 hour

Inspection and Repair

When **inspection and repair** have been performed, submit a warranty claim using the following information:

CAMPAIGN NUMBER	2011-0003
Claim Type	Campaign claim
Action	Inspect and repair
Flat Rate Time	0.4 hour

Click in both the *INSPECT BOX* and the *REPAIR BOX* while completing your claim on BOSSWeb.

INSPECT	✓
---------	---

REPAIR	✓
--------	---

NOTE: If repair is performed, you need to click in the *INSPECT BOX* and in the *REPAIR BOX* to be paid accordingly.

Parts Return Procedure

For claiming procedure, refer to *DEALER/DISTRIBUTOR WARRANTY GUIDE*.

IMPORTANT: Dealers must return defective parts to support their claims.

Shipping Addresses

USA DEALERS	BRP c/o Warranty Department 7575 Bombardier Court Wausau, WI 54401
CANADIAN DEALERS	BRP Warranty Parts Inspection Center 565 de la Montagne Valcourt, QC, J0E 2L0

Warranty Shipping Address Decals

Warranty shipping address decals can be ordered if needed.

COUNTRY	P/N
U.S.A.	490 901 601
Canada	484 500 001

SERIAL NUMBER LISTING OF VEHICLES

Model: A3BA

From 000817 to 000822
From 000824 to 000829
From 000835 to 000839
From 000843 to 000844
From 000846 to 000849
000852
000973
000975
000992

Model: A7BA

000433
000442
000447
000449
From 000453 to 000454
From 000457 to 000459
From 000461 to 000463
From 000465 to 000468
000694
From 000700 to 000701
000707
000711
000714
000716
From 000718 to 000720

Model: A7BC

From 000232 to 000242
000347
000352
000355
000357
From 000359 to 000361

Model: B5BA

000053
From 000055 to 000059
From 000061 to 000062
From 000064 to 000071
From 000073 to 000074
From 000076 to 000080
From 000082 to 000083
000145
000147
000150
000152
000155
From 000157 to 000159
000161
000164
From 000166 to 000168
000230
From 000233 to 000235
000242

Model: B5BA (cont'd)

000247
From 000249 to 000250

Model: B5BC

From 000099 to 000107
From 000109 to 000116
From 000118 to 000119
From 000121 to 000123
From 000125 to 000126
From 000128 to 000134
From 000243 to 000248
From 000250 to 000253
000367
000370
000374
000475
000480

Model: B5BD

000170
From 000173 to 000180
000182
From 000184 to 000185
000187
From 000192 to 000193
From 000195 to 000196
From 000198 to 000201
000203
From 000210 to 000215
From 000217 to 000222
000224
000226
000228
From 000409 to 000426
From 000428 to 000429
From 000431 to 000432
000662
From 000665 to 000666
000677
000680
000684
000805
000813

SAFETY RECALL NOTICE



Bombardier Recreational Products Inc.

565 de la Montagne Street
Valcourt, Québec, Canada J0E 2L0
T 450.532.2211 F 450.532.5133

www.brp.com

Date: February 9th, 2011

Re: Reverse Actuator - Can-Am Spyder™ RT SM5 roadster

Dear Can-Am™ Roadster Owner,

This notice is being sent to you in accordance with the requirements of the National Traffic and Motor Vehicle Safety Act, the Canada Motor Vehicle Safety Act and other applicable laws. Bombardier Recreational Products Inc. and BRP US Inc. ("BRP") have decided that a defect which relates to motor vehicle safety exists on certain roadster models and are conducting a voluntary safety recall.

What is the potential problem?

While downshifting, it may be possible to inadvertently engage reverse without depressing the reverse button, due to a defective reverse actuator cable. If this happens while vehicle is moving forward, the rear wheel could lock and the engine could stall. If this happens while vehicle is stopped or moving forward, vehicle could back up. This condition may increase the risk of a crash possibly resulting in injury or death.

What should you do?

Call an authorized BRP Can-Am Spyder Roadster dealer and make an appointment to have your vehicle inspected and repaired if necessary. We will validate proper operation of the reverse actuator and if defective, replace the reverse actuator assembly. *This work will be performed at no charge to you.*

There are important precautions you should take until this recall has been performed:

- Be aware that it is possible that you inadvertently engage reverse while downshifting. Stay alert and make sure, while downshifting, to check that the gearbox position in the multifunction gauge does not show "R" before releasing the clutch lever. Be particularly careful when releasing the clutch lever after downshifting into 1st gear.
- Pass on this information to any other driver of your vehicle.

What to do if you feel this notice is an error?

This notice was mailed to you according to the most current information we have available. If you no longer own this vehicle or some information in this notice is incorrect, please contact BRP at your earliest convenience.

Ski-Doo
Lynx
Sea-Doo
Evinrude
Johnson
Rotax
Can-Am

For US residents only

If you believe that the dealer or BRP has failed or is unable to remedy the problem within a reasonable time, you may submit a complaint to the Administrator, National Highway Traffic Safety Administration, 1200 New Jersey Avenue S.E. Washington, D.C. 20590, or call the toll free Auto Safety Hot Line at 1-888-327-4236 (TTY: 1-800-424-9153), or go to <http://www.safercar.gov>.

For Canadian residents only

If you believe that the notification or correction is inadequate, that the manufacturer fails to correct the situation in accordance with the notification or it fails or is unable to correct the situation within 60 days, you may submit a complaint to the Road Safety and Motor Vehicle Regulation Directorate of Transport Canada at 1-800-333-0510.

If you have questions, need assistance, or to find the nearest authorized BRP Can-Am Roadster dealer:

• Visit www.can-am.brp.com

• In the US and Canada: 1-888-638-5397

9:30 to 17:30 Eastern time Monday to Thursday
10:30 to 17:30 Eastern time Friday

We apologize for any inconvenience this may cause you.
Thank you for your immediate attention to this matter.

Sincerely,

After-Sales Service Department,
Bombardier Recreational Products Inc.