

# Coachmen Motor Works LLC

51165 Green Field Parkway Bldg B, Middlebury, Indiana 46540 Ph. 574-825-1720

## SAFETY RECALL NOTICE

Dear Valued Customer:

This notice is sent to you in accordance with the requirements of the National Traffic and Motor Vehicle Safety Act. Coachmen Motor Works, LLC (formerly known as Coachmen Recreational Vehicle Company, LLC) has decided that a defect which relates to motor vehicle safety exists in vehicles it manufactured with certain plug-in remote control receivers supplied by Dimplex North America, Ltd. These remote control receivers are used to operate the electric fireplace on your vehicle.

This decision was based upon information provided by Dimplex North America that a defect exists in some of the remote control receivers that Dimplex manufactured from 1998 through 2008. Coachmen installed these kits as original equipment in vehicles it manufactured from October 2003 through September 2007. Our records indicate that you are the owner of one of the affected vehicles.

### What Vehicles are Being Recalled?

This recall potentially affects the following vehicle models and years:

<b><u>MODEL</u></b>	<b><u>MODEL YEARS</u></b>
CHAPARRAL FIFTH WHEEL TRAILERS	2007 - 2008
SOMERSET FIFTH WHEEL TRAILERS	2004 - 2006
WYOMING FIFTH WHEEL TRAILERS	2007 - 2008
SANTARA MOTORHOMES	2004 - 2005
SPORTSCOACH ELITE MOTORHOMES	2004 - 2006

Only vehicles that were equipped with one of the following plug-in remote control kits models are covered by this recall:

Model No. 47-1001

Model No. 47-1010-R

Model No. APT-1315

Doc. ID # 255K656-61-8367R (for older models that do not have a model number)

These plug-in remote control kits were sold individually and were also packaged with the following electric fireplace and stove kits:

<b>Electric Fireplace Kits</b>	<b>Electric Stove Kit</b>
BF6000	DS5598RC
BF6000*	
DF2305	
DF2603	
DFI2309	
NNF5500	

## What is the Problem?

In some instances, the plug-in remote control receiver can overheat, posing a fire hazard. You may continue to safely operate the electric fireplace or stove when connected directly to an electrical outlet without the plug-in remote control receiver.

## What We Will Do?

Coachmen Motor Works, in cooperation with Dimplex North America, will provide owners with a replacement remote control kit free of charge.

***NOTE:*** This recall is being conducted simultaneously through NHTSA and the CPSC. If you have previously received notice of this recall and received your free replacement remote control kit, there is nothing further for you to do.

## What Should You Do?

To receive a free replacement remote control kit, please do the following:

1. Locate your remote control receiver behind the electric fireplace or stove on your vehicle (if applicable, refer to the attached guide, “Remote Control Replacement Instructions for BF6000, BF6000\*, DF2603, NNF5500”); remove the receiver from the electrical outlet and unplug the fireplace or stove from the receiver.
2. Locate the Model # / Doc. ID # and Date Code of the receiver using the enclosed bulletin, “*How to Identify Recalled Plug-In Remote Control Receivers,*” as a guide.
3. Confirm that your remote control receiver is covered by this recall by comparing the Model # to the product list above. If your product is covered, please note the Model # / Doc. ID # and the Date Code in the space provided below and continue to Step 4. The recalled receiver will be replaced with a new version, Model No. 1010-R\* (note the asterisk \*). On the new version, the name “Dimplex” appears on the front of the receiver in red. If yours is a Model No. 1010-R\* you need do nothing further. Your remote has been replaced and you can continue to use it.
4. Note the make, model, model year and the vehicle identification number (VIN) of your vehicle in the space provided below.
5. Dispose of the receiver.
6. Contact Dimplex North America Technical Customer Service at 1-888-285-7773 from 8 am – 4:30 pm EST Monday through Friday. Please have your product and vehicle information readily available (as per Step 4).

If you need assistance locating the remote control receiver or locating the Model # / Doc. ID # or the Date Code on your receiver, you may contact Dimplex North America at the number listed in Step 6 for assistance.

If Dimplex North America or [VEHICLE MANUFACTURER] fail or are unable to provide a replacement remote control kit within a reasonable time, you may wish to contact the Administrator, National Highway Traffic Safety Administration, 1200 New Jersey Avenue, SE, Washington, DC 20590, or call the toll-free Auto Safety Hotline at 1-888-327-4236 (TTY: 1800-424-9153); or contact NHTSA at <http://www.safercar.gov>.

If you previously paid to replace a recalled Dimplex remote control receiver that failed due to this defect, you may be eligible to be reimbursed for your costs. Please contact Coachmen Motor Works Customer Service at 1-866-953-5555 to determine your eligibility.

If you no longer own the vehicle covered by this Safety Recall Notice, please provide the name and contact information for the new owner by calling Coachmen Motor Works Customer Service at 1-866-953-5555. This will enable us to advise the new owner of this recall. Also, under Federal law, any vehicle lessor receiving this recall notice must forward a copy of this notice to the lessee within ten (10) days.

We regret any inconvenience this may cause you, but we are initiating this action in the interest of your personal safety and satisfaction with our products.

Sincerely,

**COACHMEN MOTOR WORKS, LLC**

Enclosures: Remote Control Replacement Instructions for BF6000, BF6000\*, DF2603, NNF5500 How to Identify Recalled Plug-In Remote Control Receivers

---

***INFORMATION TO BE PROVIDED TO DIMPLEX NORTH AMERICA, LTD.***

Remote Control Receiver:

Model # / DOC. ID # \_\_\_\_\_

Date Code \_\_\_\_\_

Vehicle:

Make \_\_\_\_\_

Model \_\_\_\_\_

Year \_\_\_\_\_

Vehicle Identification Number (VIN) (17 digits) \_\_\_\_\_

## Remote Control Replacement Instructions For BF6000, BF6000\*, DF2603, NNF5500

- 1) Remove the fireplace from its installed location to access the plug-in remote control behind the unit.
- 2) If the fireplace is fixed in place, follow the following instructions for fireplace removal:

- a) Remove retaining clip using a slot screwdriver

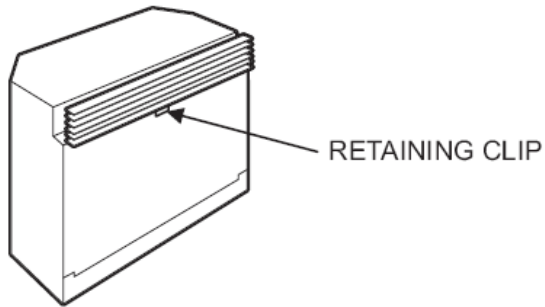

- b) Remove glass

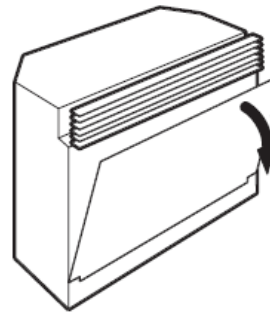

- c) Remove log set

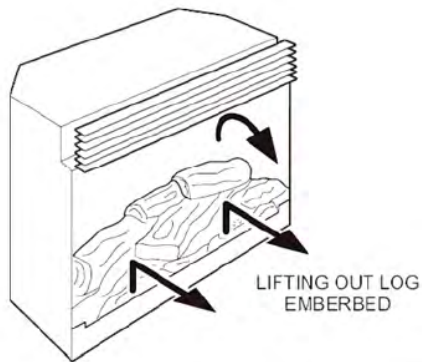

- d) Remove the screws that fasten the bottom of the fireplace to the floor.

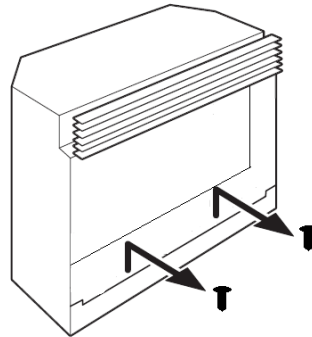

- e) Pull the fireplace from its installed location to access the plug-in remote control.

If you need assistance locating the remote control receiver or removing the fireplace to access the remote, please contact Dimplex North America Technical Customer Service at 1-888-DIMPLEX (1-888-346-7539) from 8 am – 4:30 pm Eastern Monday through Friday; when prompted, press “1” for “Customer Service” and then “1” again for “Parts Service and Technical Support”.

**How to identify recalled plug-in remote control receivers:**

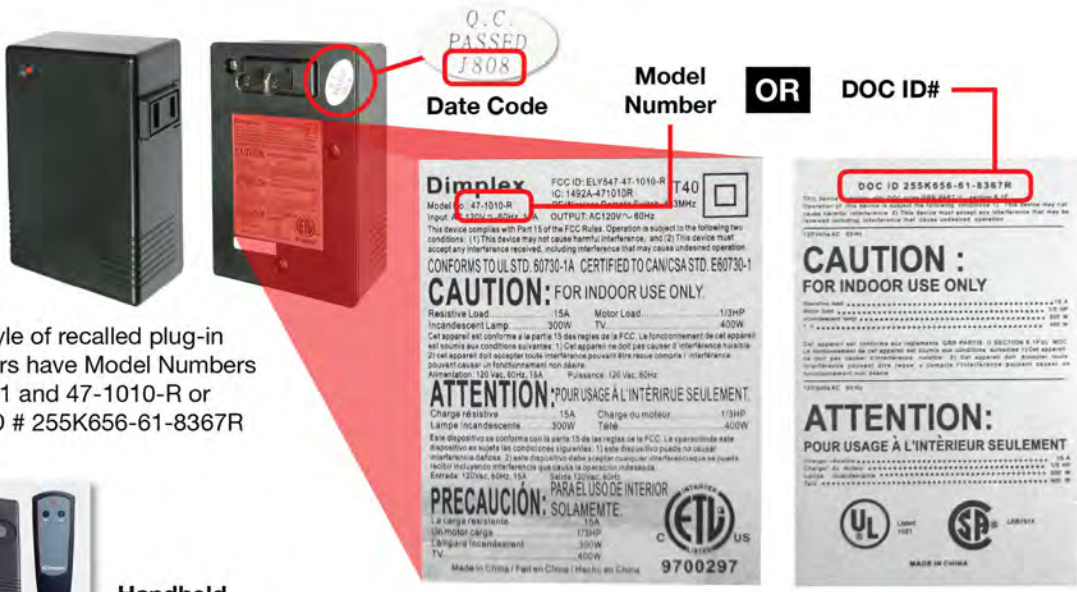

This style of recalled plug-in receivers have Model Numbers 47-1001 and 47-1010-R or DOC ID # 255K656-61-8367R



**Handheld Transmitters**

This style of recalled plug-in receiver has Model Number APT-1315

