



MOTOR COACH
INDUSTRIES

February 10, 2011

«Customer_Name»
ATTENTION: TECH SERVICE DEPT/MAINT
«Address»
«Address_2»
«City», «State» «Zip»
«ctry»

SUBJECT: SAFETY RECALL OF IDLER PULLEY COVERS
Ref.: **NHTSA # 11V-016**
MCI Service Bulletin 351

Attention Owner:

This notice is sent to you in accordance with the National Traffic and Motor Vehicle Safety Act.

Motor Coach Industries, Inc. (“MCI”) has decided that a defect which relates to motor vehicle safety exists in certain MCI D series coaches containing an idler pulley cover, part number 06-06-1629 revision A. The affected pulley covers may lack certain welds required to keep the covers attached to the coach structure. Without the welds, the cover will eventually fail as a result of fatigue, and the cover may become detached from the coach and cause personal injury or property damage. Please see the enclosed MCI Service Bulletin 351 for further information.

The vehicles that are subject to this notice are the following model year 2010 – 2011 D4000, D4500, D4505 MCI coaches (last five VIN digits):

59415	59485	59487 – 59566	59568 – 59582	59587 – 59615
59636 – 59647				

MCI is conducting a recall to inspect and replace, as necessary, the affected idler pulley covers as set forth more specifically in the enclosed MCI Service Bulletin 351. The recall work will be provided at no cost to you.

MCI records indicate that you are the owner or operator of the following vehicle(s) included in this recall:

«Unit_Numbers»

1700 EAST GOLF ROAD, SUITE 300
SCHAUMBURG, ILLINOIS 60173
847-285-2000 PHONE
866-624-2622 TOLL FREE
WWW.MCICOACH.COM

MCI strongly urges you to have the recall work performed on your vehicle(s) as quickly as possible.

You may contact the MCI Customer Service Line at 1-800-241-2947 if you have any questions about this recall campaign or wish to make arrangements to have your vehicle(s) repaired at an authorized MCI service center. Submittal of MCI Warranty Claim Forms may be completed on MCI's website at <http://fleetsupportiw.mcicoach.com/iwarranty/signon> (click on Customer Care System), or a photocopy of the Warranty Claim Form found in the Warranty Manual can be mailed / faxed to the MCI Warranty Department. Please refer to Service Bulletin 351, and your OWNER LIMITED WARRANTY MANUAL, for more detailed information.

After contacting MCI Customer Service, if you are still unable to have the safety defect remedied without charge and within a reasonable time, you may submit a complaint:

For the U.S.:

The Administrator
National Highway Traffic Safety Administration
1200 New Jersey Avenue, SE.,
Washington, DC 20590;
or call the toll-free Vehicle Safety Hotline at 1-888-327-4236; (TTY: 1-800-424-9153); or go to <http://www.safercar.gov>.

If you are the lessor of the vehicle(s) identified above, Federal law requires that you forward this notice by first class mail to the most recent lessee(s) known to you, within ten days of your receipt of this notice.

If you have sold or otherwise transferred the vehicle(s) identified above, please contact the MCI Customer Service Line at 1-800-241-2947 with all of the information you have regarding the current owner/operator of the vehicle(s).

If you had your vehicle repaired for this condition prior to receipt of this notice and incurred any costs, you may be eligible for reimbursement. Please contact the MCI Customer Service Line at 1-800-241-2947 for further information in that regard.

We regret the inconvenience this may cause you, but urge you to implement the recall procedures with respect to your vehicle(s) as soon as possible for your added safety and satisfaction.

Sincerely,

Motor Coach Industries
Warranty Department

Enclosure: MCI Service Bulletin 351

1700 EAST GOLF ROAD, SUITE 300
SCHAUMBURG, ILLINOIS 60173
847-285-2000 PHONE
866-624-2622 TOLL FREE
WWW.MCICOACH.COM



Service Bulletin No. 351

MODEL D Series Coaches	TYPE Field Change Program	SECTION/GROUP 6-Cooling	DATE Feb. 8, 2011
SUBJECT MISSING WELDS ON FAN BELT IDLER PULLEY COVER			
CONDITIONS			

Ref. NHTSA Recall No.: 11V-016

Customer Complaint:

Customers may experience damage to the fan belt idler pulley cover near the area where the cover is assembled to the coach structure. The fan belt idler pulley is designed with a cover to prevent maintenance personnel from contacting the fan drive belt at the idler pulley during maintenance operations.

Cause:

MCI has determined that the fan belt idler pulley cover may lack two welds that provide stiffness and rigidity to the part. Without these welds MCI believes that the part will eventually fail as a result of fatigue near the area where the cover is assembled to the coach structure. If a failure of both attachment areas occurs, the part may become detached from the coach and potential injury to persons and/or damage to other vehicles or property could occur.

Corrective Action:

MCI strongly encourages owners of the D4000, D4500 and D4505 model coaches listed below to implement the specified steps in this procedure as soon as possible.

59415	59485	59487-59566	59568-59582	59587-59615
59636-59647				

Parts

<u>Qty.</u>	<u>New P/N</u>	<u>Description</u>
1	06-06-1629	Cover Assembly, Idler Pulley
1	03-15-7738A	Verification Form, (Must be Returned to MCI, One Per Coach)

Service Procedure:

! WARNING

Read this entire procedure before beginning work.

Use Safe Shop Practices At All Times.

! WARNING

To avoid personal injury, never enter or perform work in the engine compartment prior to positioning the ENGINE RUN and ENGINE START switches on the engine compartment remote control box to the OFF position. Allow enough time for components to cool down prior to working in the engine compartment.

1. Turn the main battery disconnect switch to the OFF position.
2. Chock both sides of the tires.

3. Open the engine door. Locate the fan belt idler pulley cover (refer to Figure 1).

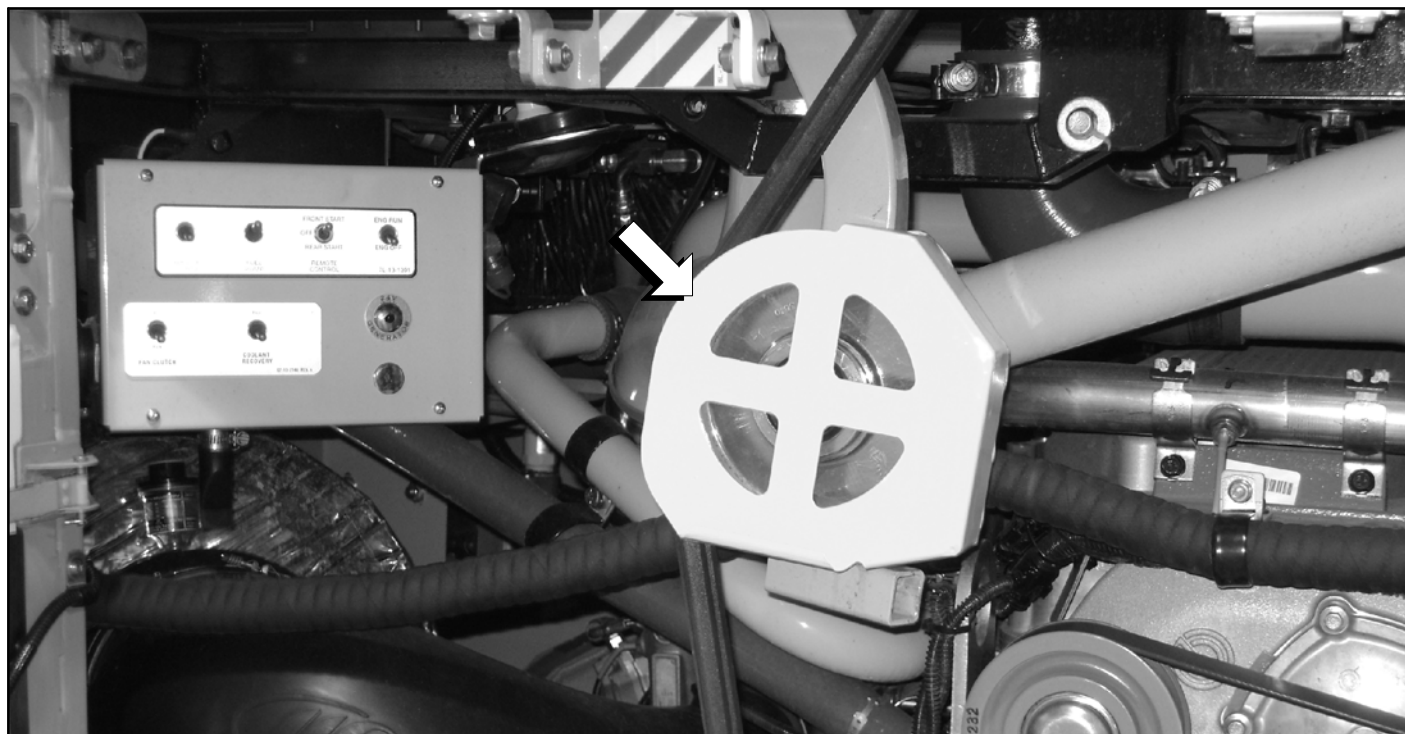

Figure 1.

4. Visually inspect the fan belt idler pulley cover for the two (2) welds shown in Figure 2

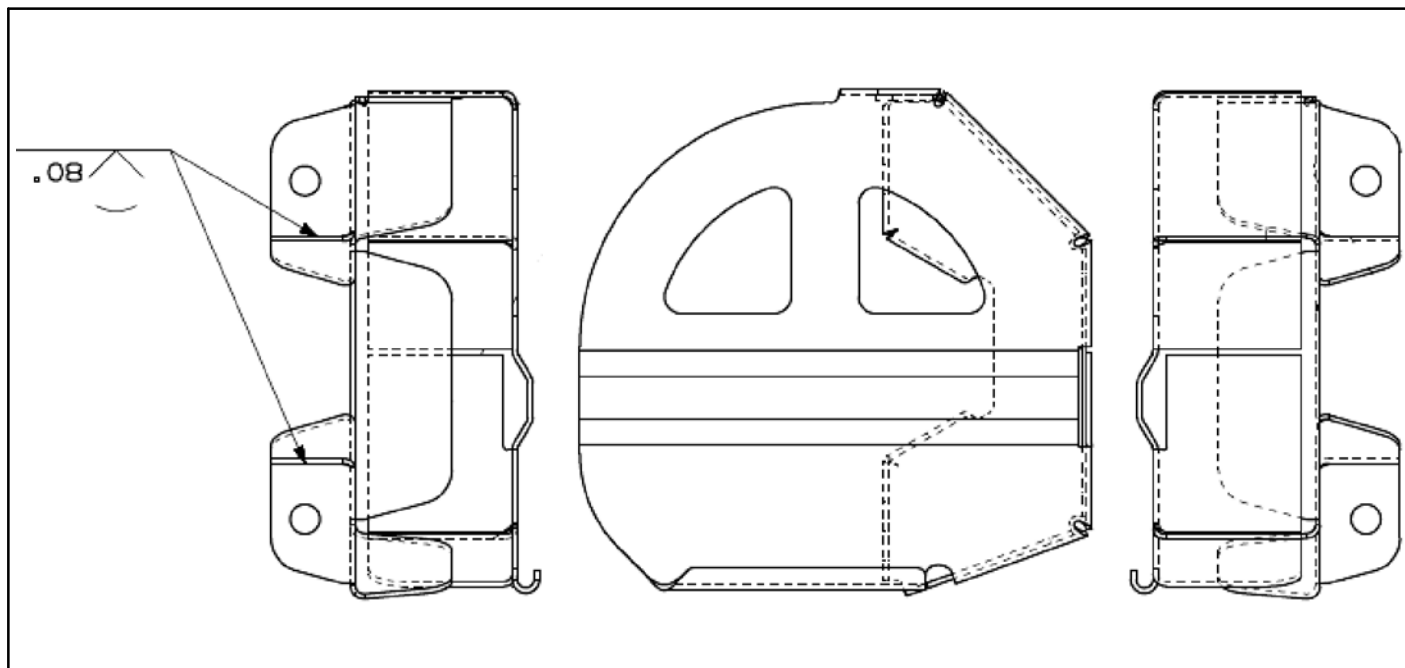

Figure 2.

NOTICE

If the two (2) welds shown in Figure 2 are on the fan belt idler pulley cover, no further action is required. Close the engine door. Fill out the attached verification form and submit to MCI's warranty department.

If the two (2) welds shown in Figure 2 are not on the fan belt idler pulley cover, proceed to Step 5.

5. Remove and retain the idler pulley cover mounting hardware (refer to Figure 3). Discard the existing idler pulley cover.
6. Using the existing mounting hardware, install the new idler pulley cover, p/n 06-06-1629.
7. Torque to 43–47 ft.-lbs. Apply torque seal from the face of the capscrew to the face of the cover.

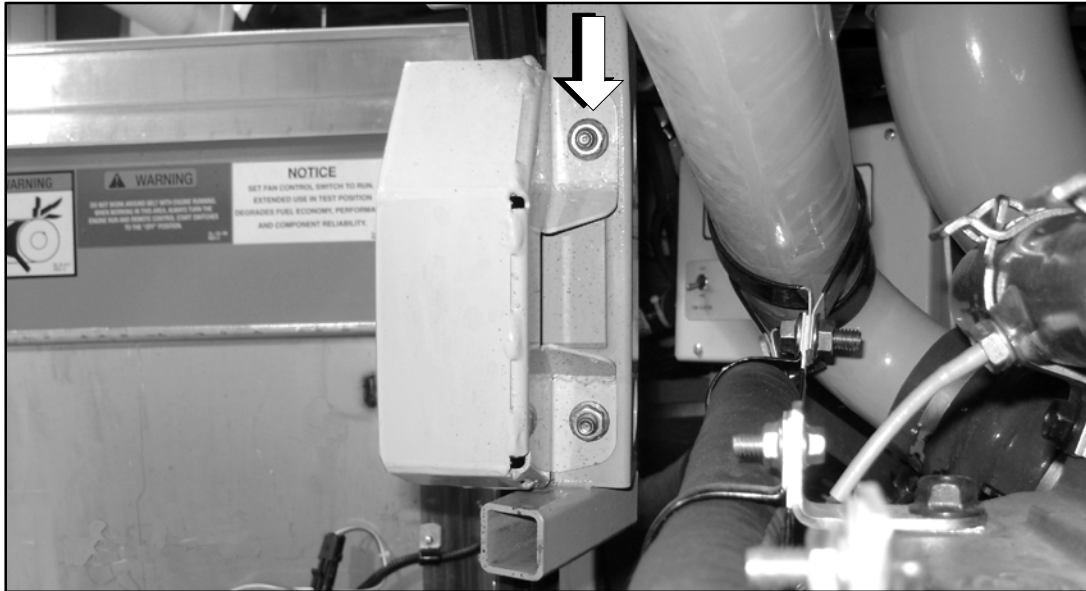

Figure 3.

Procedure complete.

Mail or fax the completed limited warranty claim form and verification form to MCI's warranty department, or photocopy and mail to:

MCI Fleet Support
Attn: Warranty Department
7001 Universal Coach Drive
Louisville, KY 40258
Fax Number 1-800-360-8886

to receive credit for the hours used to complete this task. Contact the MCI Fleet Support Technical Center at 1-800-241-2947 for any further information.

Field Change Program Conditions:

The parts required for this change will be supplied without charge.

A labor allowance of 0.3 hours will be granted, for the procedure of installing the specified part(s) in this bulletin on D Series coaches.

This labor allowance will be credited to your MCI Fleet Support Parts Account on receipt of the attached "MCI Field Change Program Verification Form" and a "Warranty Claim Form" as detailed in your Owner Warranty manual to MCI's Warranty department. A "MCI Field Change Program Verification Form" needs to be submitted for each VIN affected. Photocopy the attached "MCI Field Change Program Verification Form" as required for the number of affected coaches in your fleet.

Motor Coach apologizes for any inconvenience resulting from this campaign, but urges you to implement this change as soon as possible.

Sincerely,

Motor Coach Industries
U.S. and Canadian Service Departments.



MOTOR COACH
INDUSTRIES

MCI FIELD CHANGE PROGRAM (FCP) VERIFICATION

CONTACT INFORMATION	
CUSTOMER NAME: _____	
(PLEASE PRINT)	
FCP INFORMATION – ONE FORM PER UNIT	
FCP#: _____ Coach Model _____ Model Year _____	
COACH SERIAL #: (At least the last 5 digits)	DATE COMPLETED __ / __ / __
MILEAGE:	
<u>IMPORTANT:</u> TO RECEIVE CREDIT FOR ANY ALLOWABLE LABOR CHARGES, THIS VERIFICATION FORM MUST BE RETURNED TO MCI UPON COMPLETION OF THE FCP.	
SUBMITTED BY: (Please Print) _____ DATE __ / __ / __	
TITLE: (Please Print) _____	
SIGNATURE: _____	
COMMENTS: _____	

FAX TO: 1-502-318-8183

MAILING ADDRESS:

**MOTOR COACH INDUSTRIES
ATTN: WARRANTY DEPT.
7001 UNIVERSAL COACH DRIVE
LOUISVILLE, KY 40258**

MCI PART #03-15-7738