

DAIMLER

Daimler Trucks North America

Nasser Zamani
Senior Manager
Compliance and Regulatory Affairs

January 3, 2012

Nancy Lewis
Associate Administrator of Vehicle Safety
National Highway Traffic Safety Administration
1200 New Jersey Avenue S.E.
Washington, D.C. 20590

**RE: Defect Information Report – Supplemental Report No. 1
11V-558, FL-618, Meritor Axle Tower Bracket Welds
Dealer Notice**

Ms. Lewis,

In accordance with Part 573 of Title 49 of the Code of Federal Regulations, Daimler Trucks North America LLC herewith submits supplemental defect information and copies of documents distributed to dealers.

- (c)(3) Total number of vehicles potentially affected: 3
- (c)(8)(ii) Dealer and distributor notification: Began and ended: December 30, 2011
- (c)(10) A copy of communications sent to dealers is attached.

Please contact me if you have any questions, or concerns.

Sincerely yours,



Nasser Zamani

Cc: Amy Martin, CAL-OSHA
Attachment

Daimler Trucks North America LLC
4747 N. Channel Ave.
Portland, OR 97217-7699
(503) 745-6910 Phone
(503) 745-5544 Fax
Nasser.Zamani@Daimler.com

Subject: Meritor Axle Tower Bracket Welds

Models Affected: Specific Western Star 4900 vehicles manufactured December 14, 2010, through January 26, 2011, with Meritor drive axles.

General Information

Daimler Trucks North America LLC, on behalf of its wholly owned subsidiary, Western Star Truck Sales, Inc., has decided that a defect that relates to motor vehicle safety exists on the vehicles mentioned above.

There are six vehicles involved in this campaign.

In certain drive axle assemblies, the weld that attaches a tower bracket to the housing may crack as a result of improper welding procedures. If a weld cracks, the bracket could detach, leading to a loss of vehicle control and possible vehicle crash.

The welds will be inspected and repaired as necessary.

Additional Repairs

Dealers must complete all outstanding recall and field service campaigns prior to the sale or delivery of a vehicle. A Dealer will be liable for any progressive damage that results from its failure to complete campaigns before sale or delivery of a vehicle.

Owners may be liable for any progressive damage that results from failure to complete campaigns within a reasonable time after receiving notification.

Work Instructions

Please refer to the attached work instructions. Prior to performing the campaign, check the vehicle for a completion sticker (Form WAR260).

Replacement Parts

Replacement parts are not needed for this Recall.

Removed Parts

Please follow Warranty Failed Parts Tracking shipping instructions for the disposition of all removed parts.

Labor Allowance

Table 1 - Labor Allowance

Campaign Number	Procedure	Time Allowed (hours)	SRT Code	Damage Code
FL618A	Inspect tower bracket welds	0.3	996-0864A	000-Inspected
	Inspect and repair tower bracket welds One differential housing (Includes taking a photo and emailing information to the axle manufacturer)	3.8	996-0864B	000-Modifiedx
	Inspect and repair tower bracket welds Both differential housings (Includes taking a photo and emailing information to the axle manufacturer)	6.0	996-0864C	000-Modifiedx

Table 1

Recall Campaign

Daimler Trucks
North America LLC

December 2011
FL618A
NHTSA #11V-558
Transport Canada #11-407

IMPORTANT: When the recall has been completed, locate the base completion label in the appropriate location on the vehicle, and attach the red completion sticker provided in the recall kit (Form WAR260). If the vehicle does not have a base completion label, clean a spot on the appropriate location of the vehicle and first attach the base completion label (Form WAR259). If a recall kit is not required or there is no completion sticker in the kit, write the recall number on a blank sticker and attach it to the base completion label.

Claims for Credit

You will be reimbursed for your parts, labor, and handling by submitting your claim through the Warranty system within 30 days of completing this campaign. Please reference the following information in QuickClaim:

- Refer to Table 2 - Involved Axles when completing claims.
- Claim type is **Recall**.
- In the FTL Authorization field, enter the campaign number and appropriate condition code (**FL618A**).
- In the Primary Failed Part Number field, enter **25-FL618-000**.
- In the Parts field, enter the appropriate kit number(s) as shown in the Replacement Parts Table.
- In the Labor field, first enter the appropriate SRT from the Labor Allowance Table. For administrative time, enter SRT 939-0010A for 0.3 hours.
- For OWL, the VMRS Component Code is 022-001-001.
- **Reimbursement for Prior Repairs.** When a customer asks about reimbursement, please do the following.
 - Accept the documentation of the previous repair.
 - Make a brief check of the customer's paperwork to see if the repair may be eligible for reimbursement. (See the "Copy of Owner Letter" section of this bulletin for reimbursement guidelines for this recall.)
 - Submit a Campaign Pre-Approval inquiry to the Warranty Campaigns Department for a decision and authorization number.
 - Include the approved amount on your claim in sublet/outside purchases.
 - In the claim story, first note the authorization number and that the claim includes a reimbursement request.
 - Retain the documentation and provide it to Warranty Campaigns or Claims Processing if requested.
 - When your claim is paid, reimburse the customer the appropriate amount.

IMPORTANT: ServicePro must be viewed prior to performing the recall to ensure the vehicle is involved and the campaign has not been previously completed. Also, check for a completion sticker prior to beginning work.

Contact the Warranty Campaigns Department from 7:00 a.m. to 4:00 p.m. Pacific Time, Monday through Friday, via Web inquiry at AccessFreightliner.com / Support / My Tickets and Submit an Inquiry, or the Customer Assistance Center at (800) 385-4357, after normal business hours, if you have any questions or need additional information.

To return excess kit inventory related to this campaign, U.S. dealers must submit a Parts Authorization Return (PAR) to the Memphis PDC. Canadian dealers must submit a PAR to their facing PDC. All kits must be in resalable condition. PAR requests must include the original purchase invoice number.

The letter notifying vehicle owners is included for your reference.

**December 2011
FL618A
NHTSA #11V-558
Transport Canada #11-407**

Please note that the National Traffic and Motor Vehicle Safety Act, as amended (Title 49, United States Code, Chapter 301), requires the owner's vehicle(s) be corrected within a reasonable time after parts are available to you. The Act states that failure to repair a vehicle within 60 days after tender for repair shall be prima facie evidence of an unreasonable time. However, circumstances of a particular situation may reduce the 60 day period. Failure to repair a vehicle within a reasonable time can result in either the obligation to (a) replace the vehicle with an identical or reasonably equivalent vehicle, without charge, or (b) refund the purchase price in full, less a reasonable allowance for depreciation. The Act further prohibits dealers from selling a vehicle unless all outstanding recalls are performed. Any lessor is required to send a copy of the recall notification to the lessee within 10 days. Any subsequent stage manufacturer is required to forward this notice to its distributors and retail outlets within five working days.

Recall Campaign

Daimler Trucks
North America LLC

December 2011
FL618A
NHTSA #11V-558
Transport Canada #11-407

Copy of Notice to Owners Subject: Meritor Axle Tower Bracket Welds

For the Notice to U.S. Customers: This notice is sent to you in accordance with the requirements of the National Traffic and Motor Vehicle Safety Act.

For the Notice to Canadian Customers: This notice is sent to you in accordance with the Canadian Motor Vehicles Safety Act.

Daimler Trucks North America LLC, on behalf of its wholly owned subsidiary, Western Star Truck Sales, Inc., has decided that a defect which relates to motor vehicle safety exists on specific Western Star 4900 vehicles manufactured December 14, 2010, through January 26, 2011, with Meritor drive axles.

In certain drive axle assemblies, the weld that attaches a tower bracket to the housing may crack as a result of improper welding procedures. If a weld cracks, the bracket could detach, leading to a loss of vehicle control and possible vehicle crash.

The welds will be inspected and repaired as necessary.

Please contact an authorized Daimler Trucks North America dealer to arrange to have the recall performed and to ensure that parts are available at the dealership. To locate an authorized dealer, search online at www.Daimler-TrucksNorthAmerica.com. The Recall inspection will take up to approximately an hour and a weld repair, if needed, will take between four and six hours and will be performed at no charge to you.

You may be liable for any progressive damage that results from your failure to complete the Recall within a reasonable time after receiving notification

If you do not own the vehicle that corresponds to the identification number(s) which appears on the Recall Notification, please return the notification to the Warranty Campaigns Department with any information you can furnish that will assist us in locating the present owner. If you have leased this vehicle, Federal law requires that you forward this notice to the lessee within 10 days. If you are a subsequent stage manufacturer, Federal law requires that you forward this notice to your distributors and retail outlets within five working days. If you have paid to have this recall condition corrected prior to this notice, you may be eligible to receive reimbursement. Please see the reverse side of this notice for details.

For the Notice to U.S. Customers: If you have questions about this Recall, please contact the Warranty Campaigns Department at (800) 547-0712, 7:00 a.m. to 4:00 p.m. Pacific Time Monday through Friday, e-mail address DTNA.Warranty.Campaigns@Daimler.com, or the Customer Assistance Center at (800) 385-4357 after normal business hours. If you are not able to have the defect remedied without charge and within a reasonable time, you may wish to submit a complaint to the Administrator, National Highway Traffic Safety Administration, 1200 New Jersey Avenue, SE., Washington, DC 20590; or call the Vehicle Safety Hotline at (888) 327-4236 (TTY: 800-424-9153); or to <http://www.safercar.gov>.

For the Notice to Canadian Customers: If you have questions about this Recall, please contact the Warranty Campaigns Department at (800) 547-0712, 7:00 a.m. to 4:00 p.m. Pacific Time Monday through Friday, e-mail address DTNA.Warranty.Campaigns@Daimler.com, or the Customer Assistance Center at (800) 385-4357 after normal business hours.

We regret any inconvenience this action may cause but feel certain you understand our interest in motor vehicle safety.

WARRANTY CAMPAIGNS DEPARTMENT

Enclosure

Reimbursement to Customers for Repairs Performed Prior to Recall

If you have already **paid** to have this recall condition corrected you may be eligible to receive reimbursement.

Requests for reimbursement may include parts and labor. Reimbursement may be limited to the amount the repair would have cost if completed by an authorized Daimler Trucks North America LLC dealer. The following documentation must be presented to your dealer for consideration for reimbursement.

Please provide original or clear copies of all receipts, invoices, and repair orders that show:

- The name and address of the person who paid for the repair.
- The Vehicle Identification Number (VIN) of the vehicle that was repaired.
- What problem occurred, what repair was done, when the repair was done.
- Who repaired the vehicle.
- The total cost of the repair expense that is being claimed.
- Proof of payment for the repair (such as the front and back of a cancelled check or a credit card receipt).

Reimbursement will be made by check from your Daimler Trucks North America LLC dealer.

Please speak with your Daimler Trucks North America LLC authorized dealer concerning this matter.

Recall Campaign

Daimler Trucks
North America LLC

December 2011
FL618A
NHTSA #11V-558
Transport Canada #11-407

Work Instructions

Subject: Meritor Axle Tower Bracket Welds

Models Affected: Specific Western Star 4900 vehicles manufactured December 14, 2010, through January 26, 2011, with Meritor drive axles.

General Information

Table 2 - Involved Axles

For each vehicle, inspect the axle(s) called out below.

Vehicle	Axle(s) to Inspect
5KKHALCG2BP-BB6379	Forward Rear Axle
5KKHALCG9BP-BB6380	Rear Rear Axle
5KKXAC002BP-BB8006	Both Rear Axles
5KKXAC004BP-BB8007	Both Rear Axles
5KKMABDR2BP-BC1901	Both Rear Axles
5KKMAEDV1BP-BC5517	Both Rear Axles

Table 2

Weld Inspection

1. Check the base label (Form WAR259) for a completion sticker for FL618 (Form WAR260) indicating this work has been done. The base label is usually located on the passenger-side door, about 12 inches (30 cm) below the door latch. If a sticker is present, no work is needed. If no sticker is present, continue with the next step.
2. Park the vehicle on a level surface, shut down the engine, and set the parking brake. Chock the tires.

WARNING

To prevent serious eye injury, wear safe eye protection when performing vehicle maintenance or service.

CAUTION

Solvent cleaners can be flammable, poisonous, and cause burns. Examples of solvent cleaners are carbon tetrachloride and emulsion-type and petroleum-base cleaners. Read the manufacturer's instructions before using a solvent cleaner, then carefully follow the instructions and observe the following precautions:

- Wear skin-protecting clothing.
- Work in a well-ventilated area.
- Do not use gasoline or solvents that contain gasoline.
- Before using hot solution tanks or alkaline solutions, read the manufacturer's instructions and follow them carefully.

NOTE: For additional Meritor service information, refer to their "Literature on Demand" tool at www.meritor.com.

3. Clean the affected region around the tower bracket, front and back. Use a cleaning solvent and wire brush to remove dirt and grease. Visually inspect for cracks around the Chalmers tower bracket weld. See Fig. 1.
4. Using a die penetrant, check the tower bracket weld for cracking. Refer to the product manufacturer's instructions for correct procedures.
5. Inspect the weld for a crack.
 - If no crack is found, clean a spot on the base label (Form WAR259), write the recall number, FL618, on a blank red completion sticker (Form WAR260), and attach it to the base label. No more work is required.
 - If a crack is found, take a clear, detailed photo of the crack on the bracket, and email it along with the axle housing serial number, VIN, vehicle mileage, in-service date, to the OnTrac Customer Service Center at OnTrac@Meritor.com. In the email subject line, enter "DTNA Recall FL618 - Axle Welds." Then complete the "Weld Repair Procedure" in these work instructions.

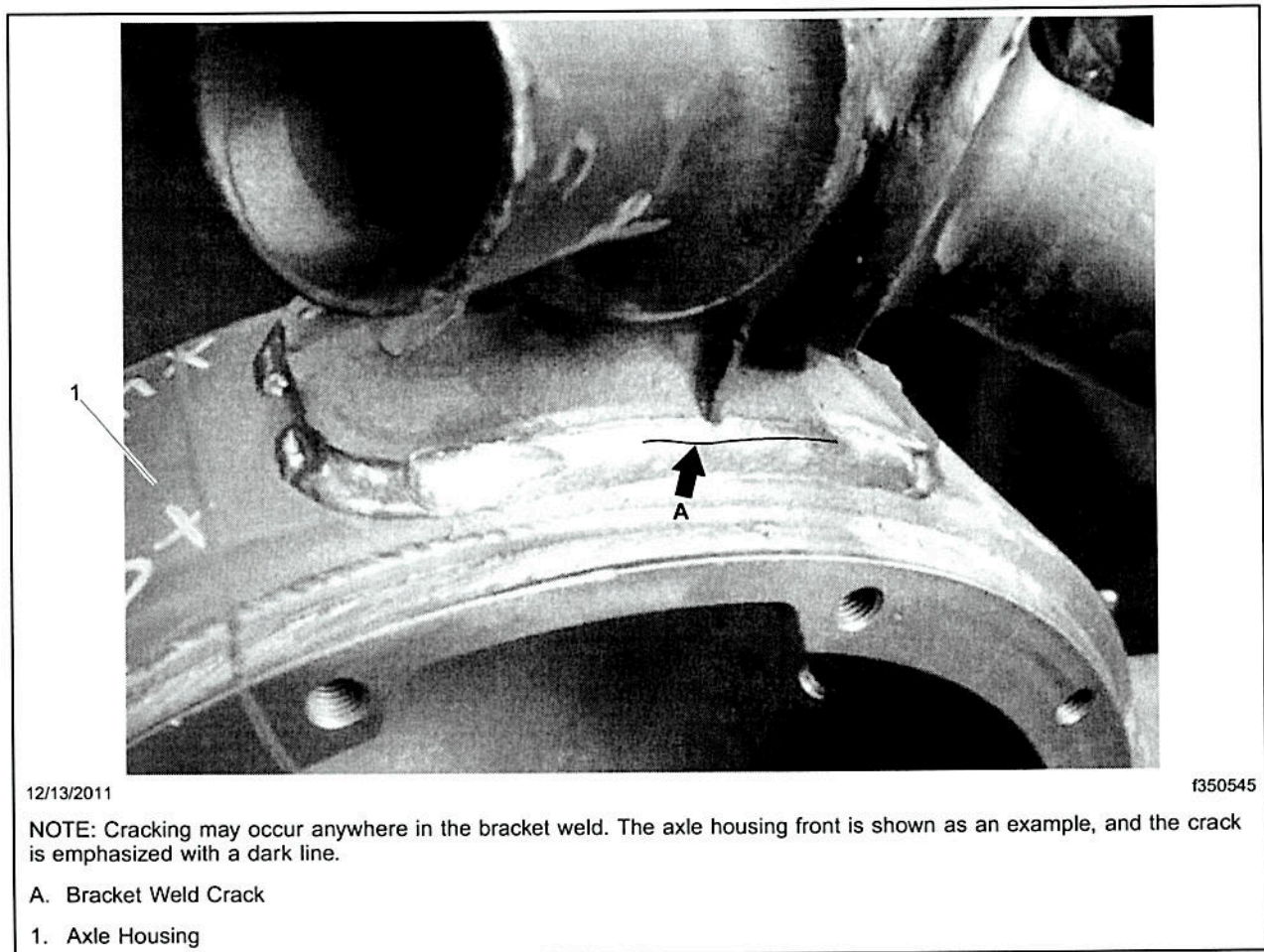

Fig. 1, Bracket Weld, Cracked

Recall Campaign

Daimler Trucks
North America LLC

December 2011
FL618A
NHTSA #11V-558
Transport Canada #11-407

Weld Repair

Remove the Suspension Arms, Axle Shafts, and Differential Carrier from the Housing

CAUTION

Support the vehicle with safety stands. Do not work under a vehicle supported only by jacks. Jacks can slip and fall over. Serious personal injury and damage to components can result.

1. Raise the rear of the vehicle until the tires clear the ground. Then place safety stands under the axle.
2. Back off the slack adjuster to release the rear axle brake shoes.
3. Remove both wheel and tire assemblies.
4. Remove the suspension arms from the tower bracket. For instructions, see **Section 32.10, Subject 150** of the *Western Star Workshop Manual*.
5. Disconnect the driveline universal joint from the pinion input yoke or flange on the carrier. For instructions, see **Section 41.00** of the *Western Star Workshop Manual*.
6. Remove the oil drain plug from bottom of the axle housing and drain the oil into a suitable, clean container. Save the oil for reuse. Reinstall the drain plug.
7. Remove the capscrews and washers or stud nuts and washers, if equipped, from the flanges of both axle shafts.

NOTE: To loosen the axle shaft, it may be necessary to tap the flange.

8. Remove the axle shaft and gasket. Discard the gasket.
9. Cover the open end of each hub where an axle shaft was removed.

NOTICE

Remove the differential carrier from the axle housing before welding onto an axle. Do not weld onto an axle with a differential carrier installed. Electrical arcing and damage to components can result.

10. Place a hydraulic roller jack under the differential carrier to support the assembly.
11. Remove all but the top two carrier-to-housing capscrews or stud nuts and washers.
12. Loosen the top two carrier-to-housing fasteners but leave them attached to the assembly. The fasteners will hold the carrier in the housing.
13. Loosen the differential carrier in the axle housing. Use a leather mallet to hit the mounting flange of the carrier at several points.
14. Remove the top two fasteners.

NOTICE

When using a pry bar, be careful not to damage the carrier or housing flange. Damage to these surfaces will cause oil leaks.

15. Use the hydraulic roller jack to remove the carrier from the axle housing. As needed, use a pry bar that has a round end to help free the carrier from the housing.
16. Use a lifting tool to lift the differential carrier by the input yoke or flange and place the assembly in a repair stand. Do not lift it by hand.

Weld the Bracket on the Housing

WARNING

Wear safe clothing and eye protection when using welding equipment. Welding equipment can burn and cause serious personal injury. Follow the operating instructions and safety procedures recommended by the welding equipment manufacturer.

Axle weld locations and welding procedures must adhere to the Meritor standards provided in their *Maintenance Manual 8*. Welding at locations or using procedures other than those authorized by Meritor will void the warranty and can reduce axle beam fatigue life. Serious personal injury and damage to components can result.

NOTICE

Do not gouge or grind below the surface of the housing wall. Gouges in the wall can weaken the housing. Damage to components can result.

1. Use a grinder to remove the cracked weld. The weld must be removed to the base housing and bracket materials. See Fig. 2.

WARNING

The axle housing must be 70°F (21°C) or warmer before welded work begins. Do not weld onto a cold axle or weld cold parts onto an axle. Cracks in the weld area, damage to components, and serious personal injury can result.

2. Ensure that the axle housing temperature is 70°F (21°C) or warmer. If the axle housing temperature measures less than 70°F (21°C), store the axle in a heated room until the housing reaches the correct temperature.

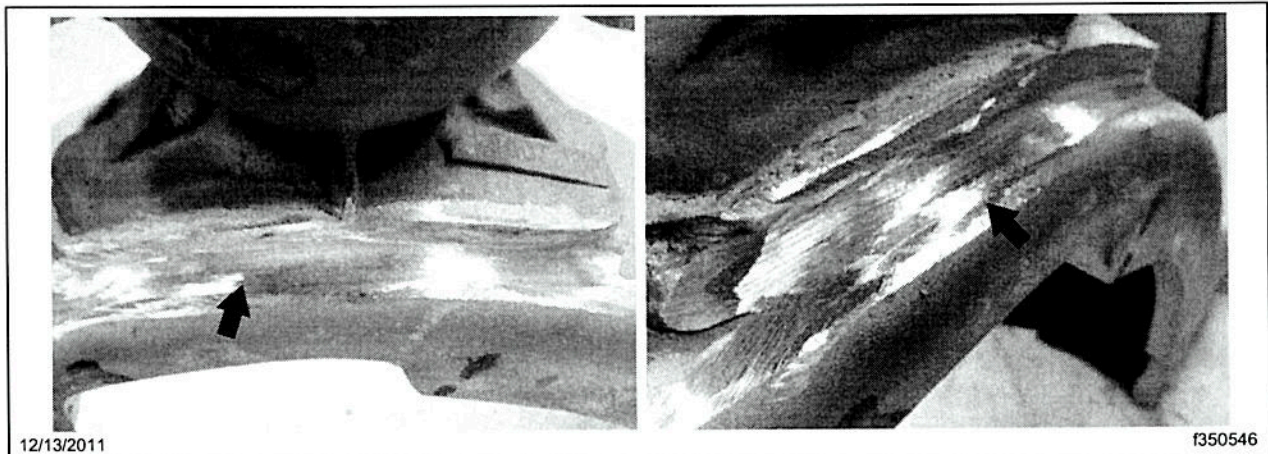

Fig. 2, Bracket Weld, Ground to Housing and Bracket Materials

Recall Campaign

Daimler Trucks
North America LLC

December 2011
FL618A
NHTSA #11V-558
Transport Canada #11-407

NOTICE

Avoid applying excessive heat to the axle housing when performing welding procedures. Extreme temperatures can damage or deform the housing, resulting in a leak at the carrier to housing interface.

- Using a suitable source of heat, heat the damaged area to approximately 300°F (149°C) before beginning welding.
- Attach the ground cable as near as possible to the cracked weld area and only to components welded on the axle, such as a housing spring pad. Do not attach the ground cable at a suspension spring, U-bolt, or at a point that places a wheel bearing between the ground connection and the weld area.
- Ensure the weld region is clean and free of paint.

IMPORTANT: Use suitable weld wire electrodes when welding. Suitable weld wire electrodes include either BS EN 499 - E 42 2 B 32 H5 or BS EN 440 - G 42 2 M GSi (American Welding Society equivalents E7018 and ER70S3, respectively). Refer to Meritor's *Maintenance Manual 8* for additional information.

- Tack weld all four corners of the bracket to the housing as shown in Fig. 3.
- Repair weld the affected region following the dimensions in Fig. 3. It is important to smoothly tie in the weld with the ends. Make sure the weld covers the upper edge of tower bracket. See Fig. 4.

NOTICE

Let the axle housing air cool to room temperature. **DO NOT** use any other method of cooling. Other methods of cooling can cause the housing to crack or become weakened.

- Let the axle housing air cool to room temperature.
- Prime and paint the affected area, if required. Cover the carrier mounting flange, as necessary, to ensure it remains free of paint.

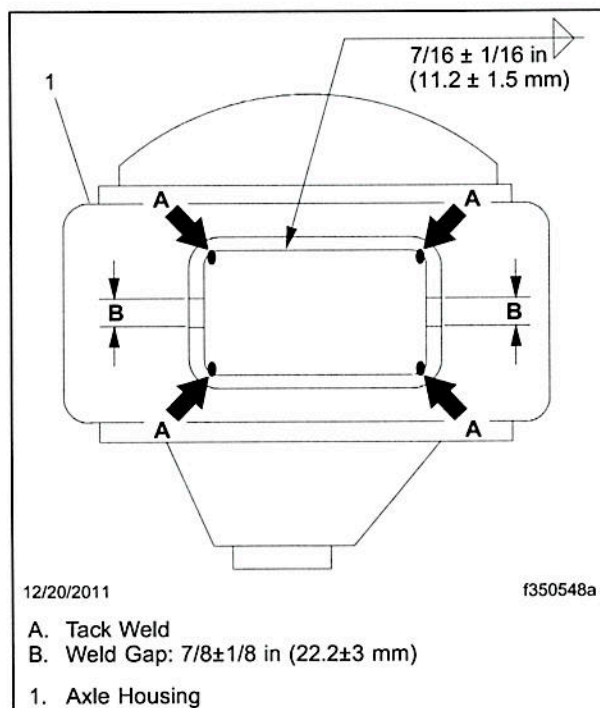

Fig. 3, New Bracket Weld, Locations and Dimensions

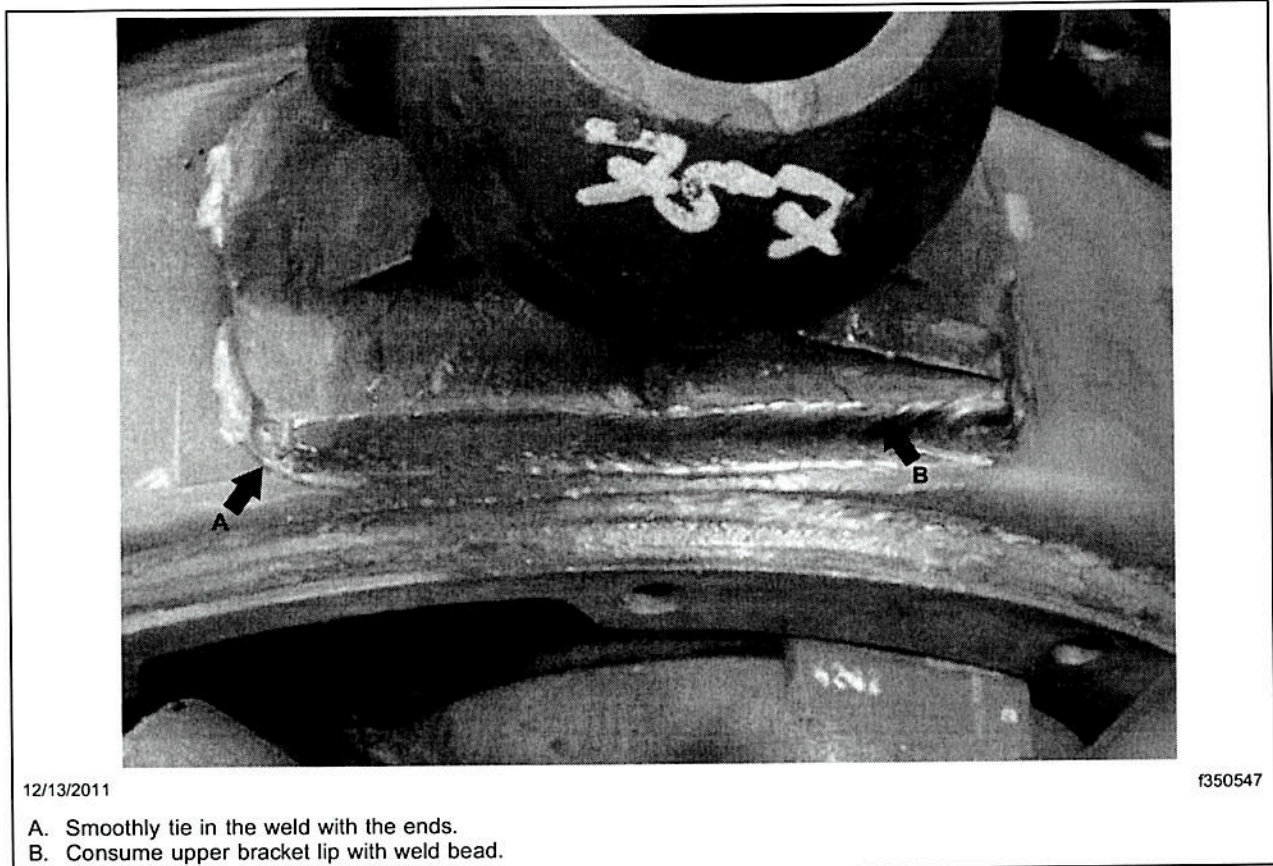

Fig. 4, New Bracket Weld, Completed

Install the Differential Carrier, Axle Shafts, and Suspension Arms

WARNING

When applying some silicone gasket materials, a small amount of acid vapor is present. To prevent serious personal injury, ensure that the work area is well-ventilated. Read the manufacturer's instructions before using a silicone gasket material, then carefully follow the instructions. If a silicone gasket material gets into your eyes, follow the manufacturer's emergency procedures, and have your eyes checked by a physician as soon as possible.

To avoid serious personal injury, be careful when using Loctite® adhesive. Read the manufacturer's instructions before using this product. Follow the instructions carefully to prevent irritation to the eyes and skin. If Loctite adhesive material gets into your eyes, follow the manufacturer's emergency procedures, and have your eyes checked by a physician as soon as possible.

NOTICE

When cleaning the silicone from the mounting surfaces, use a non-abrasive disk on the rotary tool and keep it perpendicular to the housing and carrier face. Take care to ensure not to remove the base housing flange material. Use care especially at the 6 o'clock position where most leaks occur and where there is the least amount of housing and carrier surface area. A leak can result in damage to components.

Recall Campaign

Daimler Trucks
North America LLC

December 2011
FL618A
NHTSA #11V-558
Transport Canada #11-407

1. Use a rotary tool with a scour pad to clean all silicone residue from the housing and carrier faces. See Fig. 5. Surfaces must be clean, dry, and free of foreign matter. The surfaces must not be oily to the touch.
2. Remove all debris from inside the housing. Remove metal filings from the magnets inside the housing.
3. Use a cleaning solvent, Loctite ODC-Free cleaner or brake cleaner, and rags to clean the inside of the axle housing and the carrier mounting surface.
4. Dry the housing and carrier faces.
5. For the capscrews, use a rotary wire brush to remove any thread locker material and clean the threads. Use a clean cloth to wipe the threads.
6. Use a tap to clean the internal threads in the housing.

NOTICE

Apply silicone gasket material in a continuous 0.25-inch (6 mm) bead. If using more than this amount, gasket material can break off and plug lubrication passages. Damage to components can result.

7. Apply a 1/4-inch (6 mm) bead of Loctite 5699 silicone gasket material to the housing face. Do not use ThreeBond 1216E silicone products. See Fig. 6.
8. Install two long studs in the carrier to guide the carrier into the housing.

NOTICE

Do not use a hammer or mallet to install the carriers. A hammer or mallet will damage the mounting flange of the carrier and cause oil leaks.

9. Use a hydraulic roller jack or a lifting tool to install the carrier into the axle housing. The carrier must be installed into the housing immediately once the silicone gasket material is applied to ensure the gasket material compresses evenly between the mounting faces.

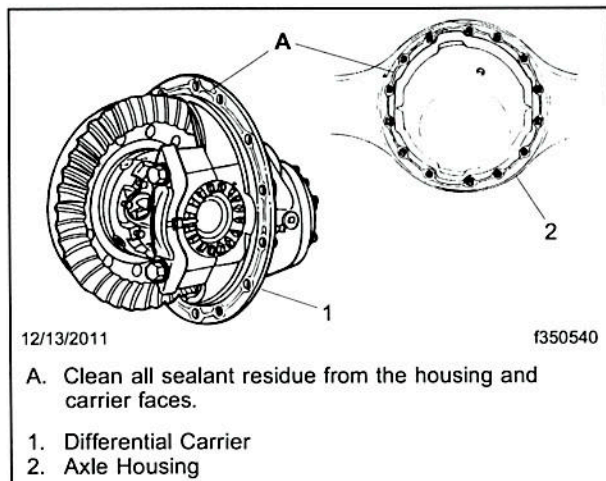

Fig. 5, Residual Sealant on Housing and Carrier

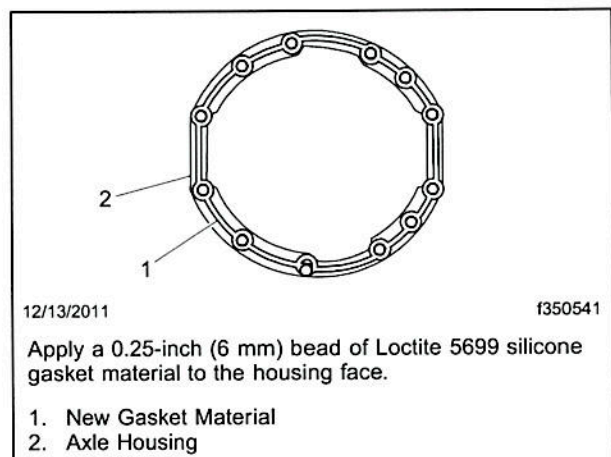

Fig. 6, New Sealant on Housing

10. Install nuts and washers or capscrews and washers, if equipped, into the locations shown in Fig. 7, and hand-tighten the fasteners.
11. Carefully push the carrier into position. Tighten the four fasteners two or three turns each in a pattern opposite each other.
12. Continue tightening the four fasteners using the same method until all are tightened to the correct torque value, as follows:
 - Tighten 1/2-inch capscrews 140 lbf-ft (190 N-m)
 - Tighten 5/8-inch capscrews 225 lbf-ft (306 N-m)
13. Install the other fasteners and washers that hold the carrier in the axle housing, and tighten them to the correct torque value.
14. Clean the mating surfaces of the axle shaft and the wheel hub.
15. If silicone gasket material is used, apply a 1/8-inch (3 mm) diameter bead of the gasket material around the mating surface of the hub and around the edge of each fastener hole.
16. Install the gasket, if used, and the axle shaft into the housing. The gasket and the flange of the axle shaft must fit flat against the wheel hub. See Fig. 8

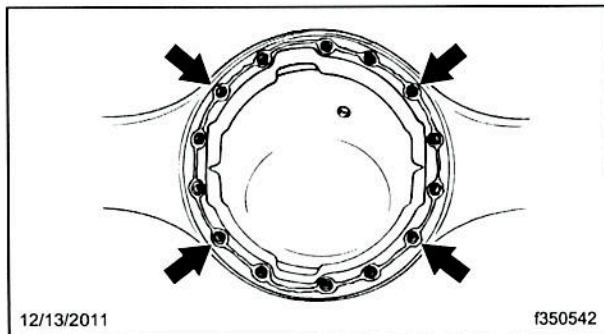

Fig. 7, Fastener Locations

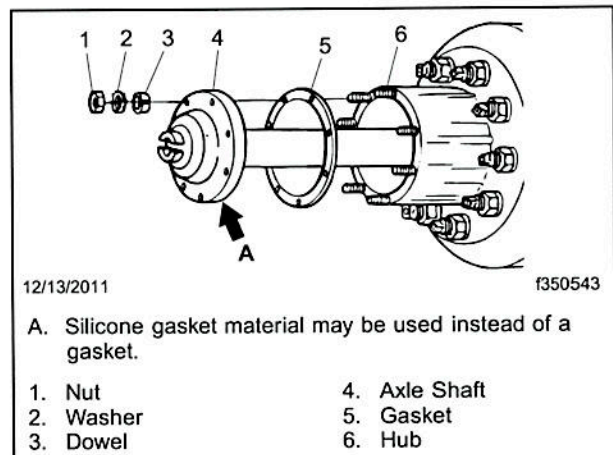

Fig. 8, Axle Shaft Installation

17. Install solid tapered dowels over each stud and into the flange of the axle shaft. Use a punch or a drift and hammer, if necessary.
18. Install the Grade 8 nuts and hardened washers onto the stud. Lock washers are an acceptable alternative. Tighten the stud nuts in the sequence shown in Fig. 9 to the torque specified in Table 3.

Torque Values, Axle Shaft Stud Nuts (Grade 8)		
Size	Plain Nut Torque: lbf-ft (N-m)	Locknut Torque: lbf-ft (N-m)
7/16-20	50-75 (81-102)	40-65 (67-88)
1/2-20	75-115 (115-156)	65-100 (102-136)
9/16-18	110-165 (176-224)	100-145 (149-197)
5/8-18	150-230 (244-312)	130-190 (203-258)

Table 3, Torque Values, Axle Shaft Stud Nuts
(Grade 8)

Recall Campaign

Daimler Trucks
North America LLC

December 2011
FL618A
NHTSA #11V-558
Transport Canada #11-407

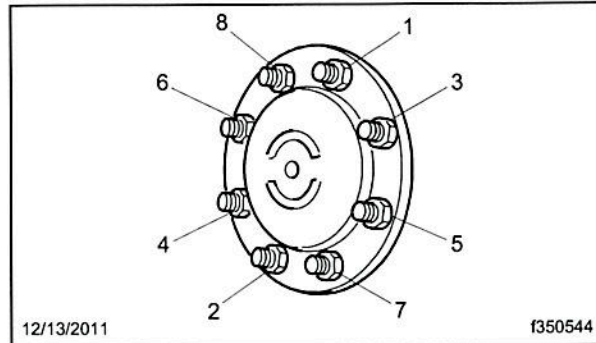

Fig. 9, Tightening Sequence, Axle Shaft Fasteners

19. Fill the axle housing with the oil removed during disassembly.
20. Install the suspension arms to the tower bracket. For instructions, see **Section 32.10, Subject 150** of the *Western Star Workshop Manual*.
21. Connect the driveline universal joint to the pinion input yoke or flange on the carrier. For instructions, see **Section 41.00** of the *Western Star Workshop Manual*.
22. Clean a spot on the base label (Form WAR259), write the recall number, FL618, on a blank red completion sticker (Form WAR260), and attach it to the base label.

**Daimler Trucks
North America LLC**

Daimler Trucks North America LLC
P.O. Box 4090
Portland, OR 97208-4090
800.547.0712 Phone
503.745.9009 Fax

**December 2011
FL618A
NHTSA #11V-558**

Subject: Meritor Axle Tower Bracket Welds

This notice is sent to you in accordance with the requirements of the National Traffic and Motor Vehicle Safety Act.

Daimler Trucks North America LLC, on behalf of its wholly owned subsidiary, Western Star Truck Sales, Inc., has decided that a defect which relates to motor vehicle safety exists on specific Western Star 4900 vehicles manufactured December 14, 2010, through January 26, 2011, with Meritor drive axles.

In certain drive axle assemblies, the weld that attaches a tower bracket to the housing may crack as a result of improper welding procedures. If a weld cracks, the bracket could detach, leading to a loss of vehicle control and possible vehicle crash.

The welds will be inspected and repaired as necessary.

Please contact an authorized Daimler Trucks North America dealer to arrange to have the recall performed and to ensure that parts are available at the dealership. To locate an authorized dealer, search online at www.Daimler-TrucksNorthAmerica.com. The Recall inspection will take up to approximately an hour and a weld repair, if needed, will take between four and six hours and will be performed at no charge to you.

You may be liable for any progressive damage that results from your failure to complete the Recall within a reasonable time after receiving notification

If you do not own the vehicle that corresponds to the identification number(s) which appears on the Recall Notification, please return the notification to the Warranty Campaigns Department with any information you can furnish that will assist us in locating the present owner. If you have leased this vehicle, Federal law requires that you forward this notice to the lessee within 10 days. If you are a subsequent stage manufacturer, Federal law requires that you forward this notice to your distributors and retail outlets within five working days. If you have paid to have this recall condition corrected prior to this notice, you may be eligible to receive reimbursement. Please see the reverse side of this notice for details.

If you have questions about this Recall, please contact the Warranty Campaigns Department at (800) 547-0712, 7:00 a.m. to 4:00 p.m. Pacific Time Monday through Friday, e-mail address DTNA.Warranty.Campaigns@Daimler.com, or the Customer Assistance Center at (800) FTL-HELP after normal business hours. If you are not able to have the defect remedied without charge and within a reasonable time, you may wish to submit a complaint to the Administrator, National Highway Traffic Safety Administration, 1200 New Jersey Avenue, SE., Washington, DC 20590; or call the Vehicle Safety Hotline at (888) 327-4236 (TTY: 800-424-9153); or to <http://www.safercar.gov>.

We regret any inconvenience this action may cause but feel certain you understand our interest in motor vehicle safety.

WARRANTY CAMPAIGNS DEPARTMENT

Enclosure

Reimbursement to Customers for Repairs Performed Prior to Recall

If you have already **paid** to have this recall condition corrected you may be eligible to receive reimbursement.

Requests for reimbursement may include parts and labor. Reimbursement may be limited to the amount the repair would have cost if completed by an authorized Daimler Trucks North America LLC dealer. The following documentation must be presented to your dealer for consideration for reimbursement.

Please provide original or clear copies of all receipts, invoices, and repair orders that show:

- The name and address of the person who paid for the repair.
- The Vehicle Identification Number (VIN) of the vehicle that was repaired.
- What problem occurred, what repair was done, when the repair was done.
- Who repaired the vehicle.
- The total cost of the repair expense that is being claimed.
- Proof of payment for the repair (such as the front and back of a cancelled check or a credit card receipt).

Reimbursement will be made by check from your Daimler Trucks North America LLC dealer.

Please speak with your Daimler Trucks North America LLC authorized dealer concerning this matter.

**Daimler Trucks
North America LLC**

Daimler Trucks North America LLC
P.O. Box 4090
Portland, OR 97208-4090
800.547.0712 Phone
503.745.9009 Fax

December 2011
FL618A
Transport Canada #11-407

Subject: Meritor Axle Tower Bracket Welds

This notice is sent to you in accordance with the Canadian Motor Vehicles Safety Act.

Daimler Trucks North America LLC, on behalf of its wholly owned subsidiary, Western Star Truck Sales, Inc., has decided that a defect which relates to motor vehicle safety exists on specific Western Star 4900 vehicles manufactured December 14, 2010, through January 26, 2011, with Meritor drive axles.

In certain drive axle assemblies, the weld that attaches a tower bracket to the housing may crack as a result of improper welding procedures. If a weld cracks, the bracket could detach, leading to a loss of vehicle control and possible vehicle crash.

The welds will be inspected and repaired as necessary.

Please contact an authorized Daimler Trucks North America dealer to arrange to have the recall performed and to ensure that parts are available at the dealership. To locate an authorized dealer, search online at www.Daimler-TrucksNorthAmerica.com. The Recall inspection will take up to approximately an hour and a weld repair, if needed, will take between four and six hours and will be performed at no charge to you.

You may be liable for any progressive damage that results from your failure to complete the Recall within a reasonable time after receiving notification

If you do not own the vehicle that corresponds to the identification number(s) which appears on the Recall Notification, please return the notification to the Warranty Campaigns Department with any information you can furnish that will assist us in locating the present owner. If you have leased this vehicle, Federal law requires that you forward this notice to the lessee within 10 days. If you are a subsequent stage manufacturer, Federal law requires that you forward this notice to your distributors and retail outlets within five working days. If you have paid to have this recall condition corrected prior to this notice, you may be eligible to receive reimbursement. Please see the reverse side of this notice for details.

If you have questions about this Recall, please contact the Warranty Campaigns Department at (800) 547-0712, 7:00 a.m. to 4:00 p.m. Pacific Time Monday through Friday, e-mail address DTNA.Warranty.Campaigns@Daimler.com, or the Customer Assistance Center at (800) FTL-HELP after normal business hours.

We regret any inconvenience this action may cause but feel certain you understand our interest in motor vehicle safety.

WARRANTY CAMPAIGNS DEPARTMENT

Enclosure

Reimbursement to Customers for Repairs Performed Prior to Recall

If you have already **paid** to have this recall condition corrected you may be eligible to receive reimbursement.

Requests for reimbursement may include parts and labor. Reimbursement may be limited to the amount the repair would have cost if completed by an authorized Daimler Trucks North America LLC dealer. The following documentation must be presented to your dealer for consideration for reimbursement.

Please provide original or clear copies of all receipts, invoices, and repair orders that show:

- The name and address of the person who paid for the repair.
- The Vehicle Identification Number (VIN) of the vehicle that was repaired.
- What problem occurred, what repair was done, when the repair was done.
- Who repaired the vehicle.
- The total cost of the repair expense that is being claimed.
- Proof of payment for the repair (such as the front and back of a cancelled check or a credit card receipt).

Reimbursement will be made by check from your Daimler Trucks North America LLC dealer.

Please speak with your Daimler Trucks North America LLC authorized dealer concerning this matter.