



## AUTOCAR INDUSTRIES SAFETY RECALL T-1101 NHTSA RECALL 11V-405

September, 2011

### Attention:

Service Managers / Parts Managers

### Subject:

ACTT Frame Reinforcement

### Safety Recall Information:

Autocar Industries has identified a defect in 13 terminal tractors built between 23 February 2011 and 24 June 2011. The defect has occurred in vehicles with severe duty applications. The affected vehicles may develop cracks mainly in the top flange of the right-hand frame rail at the clearance cut-out for the engine air inlet system. Under severe-duty applications, the frame can be subjected to high stress in this area which may eventually result in cracking of the frame rail (see Figure 1).

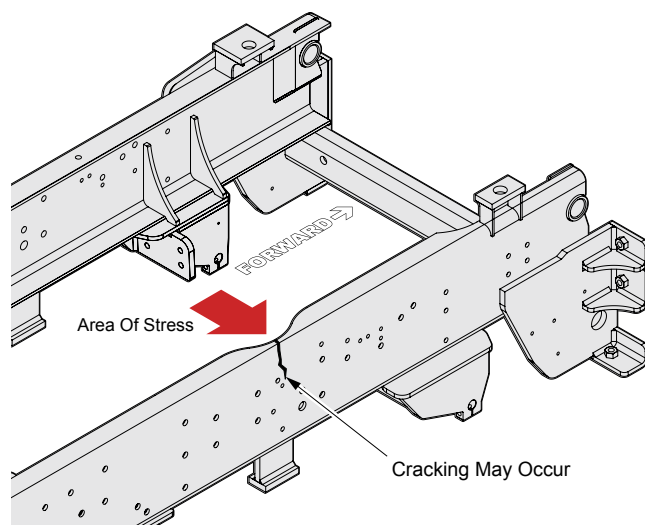

Figure 1

Questions regarding this Safety Recall should be directed to Autocar Technical Support at 888-218-3611.

### Vehicles Affected:

This Safety Recall covers 13 vehicles with serial numbers ranging from 212301 through 213169. Refer to the VIN list on page 16.

### Service Responsibility:

Service centers must perform this recall on affected vehicles at no charge to the owner regardless of vehicle mileage, age or ownership. If a vehicle affected by this recall is taken into or is currently in your vehicle inventory at your center for service, you must perform this recall before the vehicle is sold or released to the owner.

### To Obtain Parts:

Please contact Autocar at 877-973-3486, 765-489-1960 or 765-489-6016.

### Claims for Reimbursement:

Submit a claim for reimbursement in accordance with Autocar's Warranty Administration Manual.

### Claim Coding Information:

Repair Number (Op Code)	Time Allowance (SRT)	Description
1.4.1	4.50 HR	ACTT Frame Reinforcement

Autocar Industries  
551 South Washington Street  
Hagerstown, IN 47346  
877-973-3486



Questions? Visit the Autocar website at [www.autocartruck.com](http://www.autocartruck.com) and click the **Web-Link Direct** icon to request emergency service assistance.



## AUTOCAR INDUSTRIES SAFETY RECALL T-1101 NHTSA RECALL 11V-405

September, 2011

### Required Parts:

- S4030001K001 Service kit
  - (1) A4030327-001 Reinforcement plate
  - (1) A4030328-001 Template
  - (1) S4030001K002 Frame reinforcement hardware kit
    - (1) 3082808 90° Street elbow
    - (1) 3082856 T-fitting
    - (14) GE286250BI01 Locknut
    - (4) GE286262BI01 Locknut
    - (12) GE410150AI16 Bolt
    - (4) GE410162AI20 Bolt
    - (2) GZ030020-006 Bolt
    - (1) GZ200056-003 Fitting
    - (1) 3083117 Bulkhead fitting

### Tools Required:

- 1/2" Drive ratchet
- 1/2" Drive 3/4" socket
- 1/2" Drive 15/16" socket
- 15/16" Combination wrench
- 9/16" Combination wrench
- 7/16" Combination wrench
- 13/16" Combination wrench
- 3/4" Combination wrench
- 7/8" Combination wrench
- 1/2" Drive torque wrench up to 215 ft-lbs
- 9/16" Drill bit
- 3/8" Drill bit
- Drill
- Center punch
- Hammer
- Huck cutter
- Grinder

### SAFETY NOTICES

#### **CAUTION**

#### LOCKOUT/TAGOUT PROCEDURES

Before entering the vehicle or vehicle body, read and follow OSHA regulations concerning entry and working in "CONFINED SPACE" OSHA 1910.146 and "LOCKOUT/TAGOUT" OSHA 1910.147. Follow OSHA regulations while performing any work on the vehicle. The vehicle must be disabled by the following steps before performing any work on the vehicle:

1. Place the transmission in NEUTRAL.
2. Set the parking brake.
3. Shut the engine OFF.
4. Lock cab doors, keep the key in your pocket. Block the wheels before entering the body or performing any work on the vehicle.
5. Turn the battery disconnect switch OFF if equipped.
6. Completely drain the air from the primary/A system and secondary/B system by opening the drain valves on the air tanks themselves or by using the drain manifold if supplied. When draining the air tanks, do not look into the area where air is draining. Dirt or sludge particles may be expelled in the air stream and can cause eye injury.
7. Place magnetic "DANGER" signs on both cab doors before entering the body or performing any work on the vehicle.
8. Take proper precautions before working under the vehicle. Use ramps approved for the weight of your vehicle, or use floor jacks and stands. Never work under a vehicle supported by jacks alone. Always use jack stands to support the vehicle.





## AUTOCAR INDUSTRIES SAFETY RECALL T-1101 NHTSA RECALL 11V-405

September, 2011

### **WARNING**

*Allow the vehicle's engine and cooling system to cool to ambient temperature before performing the repair procedure. A hot engine or cooling assembly may cause burns or other personal injury.*

### **DANGER**

*To prevent eye injury, always wear eye protection when performing vehicle maintenance, service or inspection.*

### **DANGER**

*Before working on a vehicle, set the parking brake, place the transmission in neutral and block the wheels. Failure to do so can result in unexpected vehicle movement and can cause serious personal injury or death.*

### **CAUTION**

*Critical fasteners should be properly tightened to torque values and maintained during the service period. Refer to Autocar's preventive maintenance manual (AC-SM-177-0606-P112) for schedule.*

### **WARNING**

As you know, Autocar has emerged as the industry leader in the production and sale of natural gas engine refuse trucks in North America. This exciting green technology requires specific compliance in the service, storage and refueling of our customers' natural gas engine trucks.

If you store or dispense Compressed Natural Gas (CNG) or Liquid Natural Gas (LNG), or if you work on CNG or LNG trucks, your location must be fully compliant with applicable codes, regulations and standards, including National Fire Protection Association (NFPA) codes, Society of Automotive Engineers (SAE) standards, American National Standards Institute (ANSI), Natural Gas Vehicle (NGV) standards, the United States Code of Federal Regulations (CFR), and your state and local fire and other applicable codes (including the California Code of Regulations and the Texas Administrative Code, as applicable).

Contact your local fire department for guidance and additional compliance information. Technicians working on Autocar trucks with CNG or LNG engines must be trained in the proper repair of CNG and LNG engines and the safe storage and dispensing of CNG and LNG.





## AUTOCAR INDUSTRIES SAFETY RECALL T-1101 NHTSA RECALL 11V-405

September, 2011

### Installation of Frame Reinforcement

1. Raise the cab.

#### **DANGER**

*Due to the danger of sustaining personal injury and/or damage to the vehicle, never attempt to raise the cab outdoors under extremely windy conditions. Strong wind conditions could force the cab beyond the normal limits of its travel. Never rely on the hydraulic pressure to hold the cab in an open position. Always use the safety pin in the cab tilt lock tube to prevent serious personal injury or death.*

#### **CAUTION**

### Raising the Cab

Remove or secure all loose articles and close all doors before raising the cab. The area above and ahead of the cab must be clear from obstructions. Place front wheels in a straight ahead position.

### Raising the Cab with the Electric Pump (If equipped)

- To raise the cab with the electric pump pull up on the flow control knob (located on top of the tilt pump) until the locating pin can spin freely.
- Rotate the knob 90 degrees clockwise and release, at which point the locating pin will re-seat in the open, or up position.
- To raise the cab, push and maintain pressure on the tilt switch, located on the side of the tilt pump. The cab latch hooks securing the cab to the frame are at this point automatically released. This will be

evident when the pins at the rear of the hydraulic latch extend from the latch body.

- The hydraulic cylinders then lift the cab until the mid-point (top) is reached.

### Raising the Cab with the Manual Pump (If equipped)

- Remove the pump handle from its storage on the inside wall of the driver or passenger side door.
- Place the selector lever on the hydraulic pump in the RAISE position. Insert the pump handle into the pump and operate the handle in an up and down motion. The hydraulic cab latches will open, then the hydraulic cylinders will lift the cab until the midpoint (top) is reached.

Once the cab has reached its midpoint, the cab will move forward to the fully open position. The safety pin in the cab tilt lock device must be installed when the holes line up in the sliding bar, *some vehicles are equipped with a ladder lock mechanism that will engaged automatically.*

For vehicles equipped with manual pumps, remove the pump handle when not in use. It may stick out and could cause injury to passersby.





# SAFETY RECALL BULLETIN

**AUTOCAR INDUSTRIES SAFETY RECALL T-1101**  
NHTSA RECALL 11V-405

September, 2011

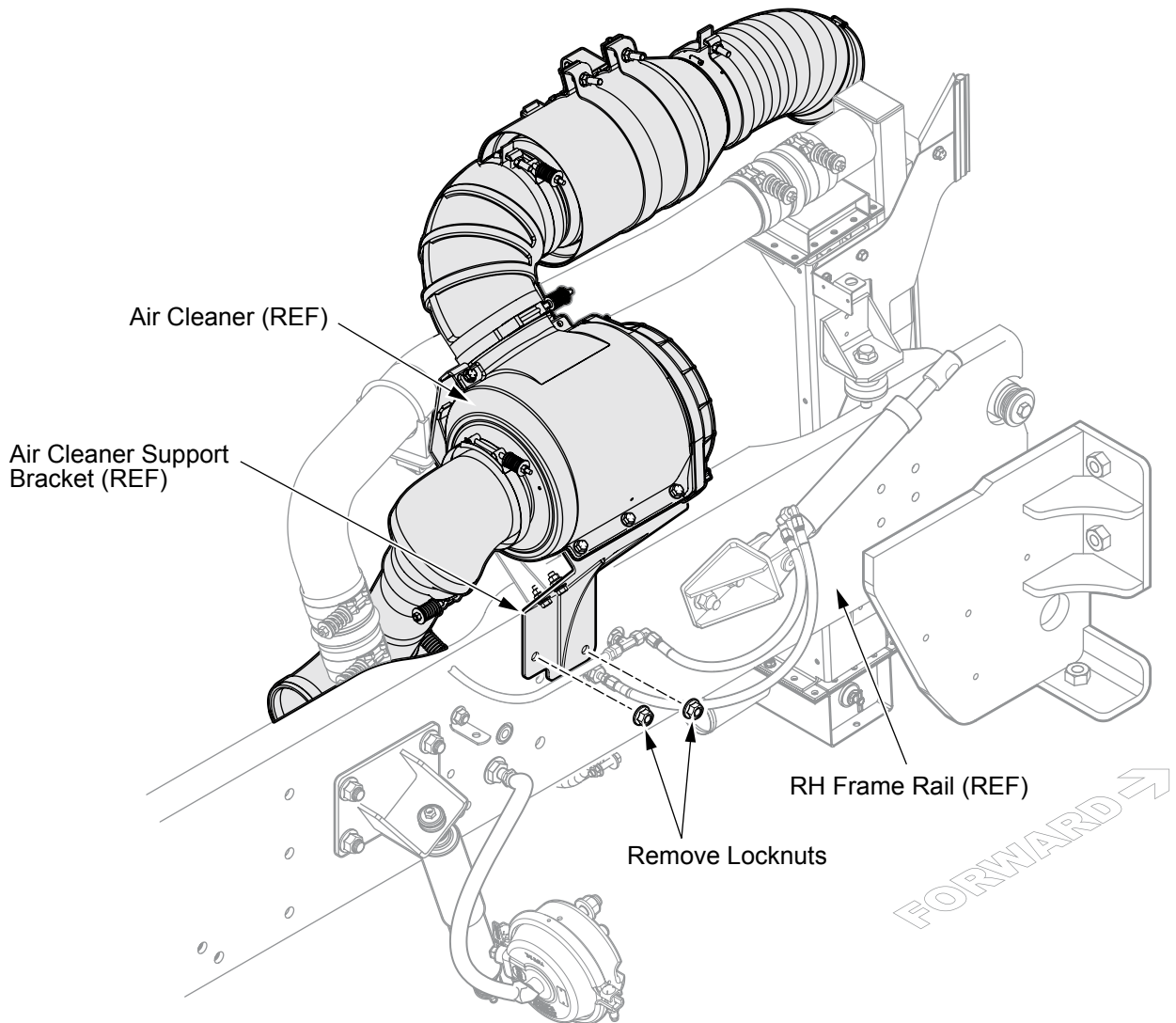

**Figure 2**

2. Locate the right side frame rail (see Figure 2).
3. Using a 1/2" drive 3/4" socket and a 3/4" combination wrench, remove and discard the two locknuts and the two bolts (not shown) securing the air cleaner support bracket to the frame rail (see Figure 2).

**Autocar Industries**  
551 South Washington Street  
Hagerstown, IN 47346  
877-973-3486



**Questions?** Visit the Autocar website at [www.autocartruck.com](http://www.autocartruck.com) and click the **Web-Link Direct** icon to request emergency service assistance.



## SAFETY RECALL BULLETIN

**AUTOCAR INDUSTRIES SAFETY RECALL T-1101**  
NHTSA RECALL 11V-405

September, 2011

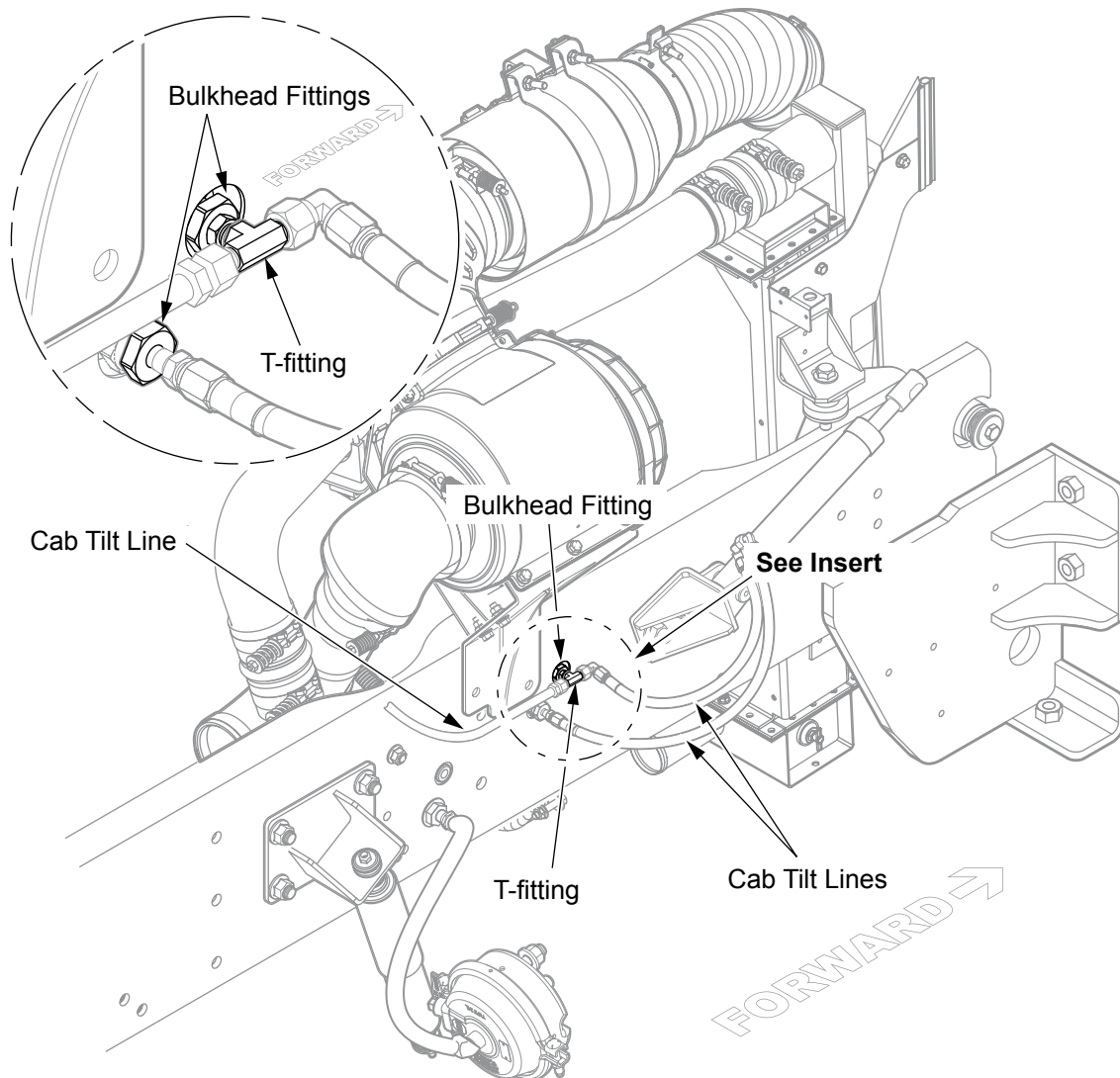

**Figure 3**

4. Locate the T-fitting on the right frame rail (see Figure 3).
5. Using a 9/16" combination wrench, disconnect the cab tilt lines from the T-fitting and the bulkhead fittings (see Figure 3).
6. Using a 7/16" combination wrench, remove the T-fitting from the bulkhead and discard (see Figure 3).
7. Using a 7/8" and a 3/4" combination wrench, remove and discard the bulkhead fitting (see Figure 3)

**Autocar Industries**  
551 South Washington Street  
Hagerstown, IN 47346  
877-973-3486



**Questions?** Visit the Autocar website at [www.autocartruck.com](http://www.autocartruck.com) and click the **Web-Link Direct** icon to request emergency service assistance.



## SAFETY RECALL BULLETIN

**AUTOCAR INDUSTRIES SAFETY RECALL T-1101**  
**NHTSA RECALL 11V-405**

September, 2011

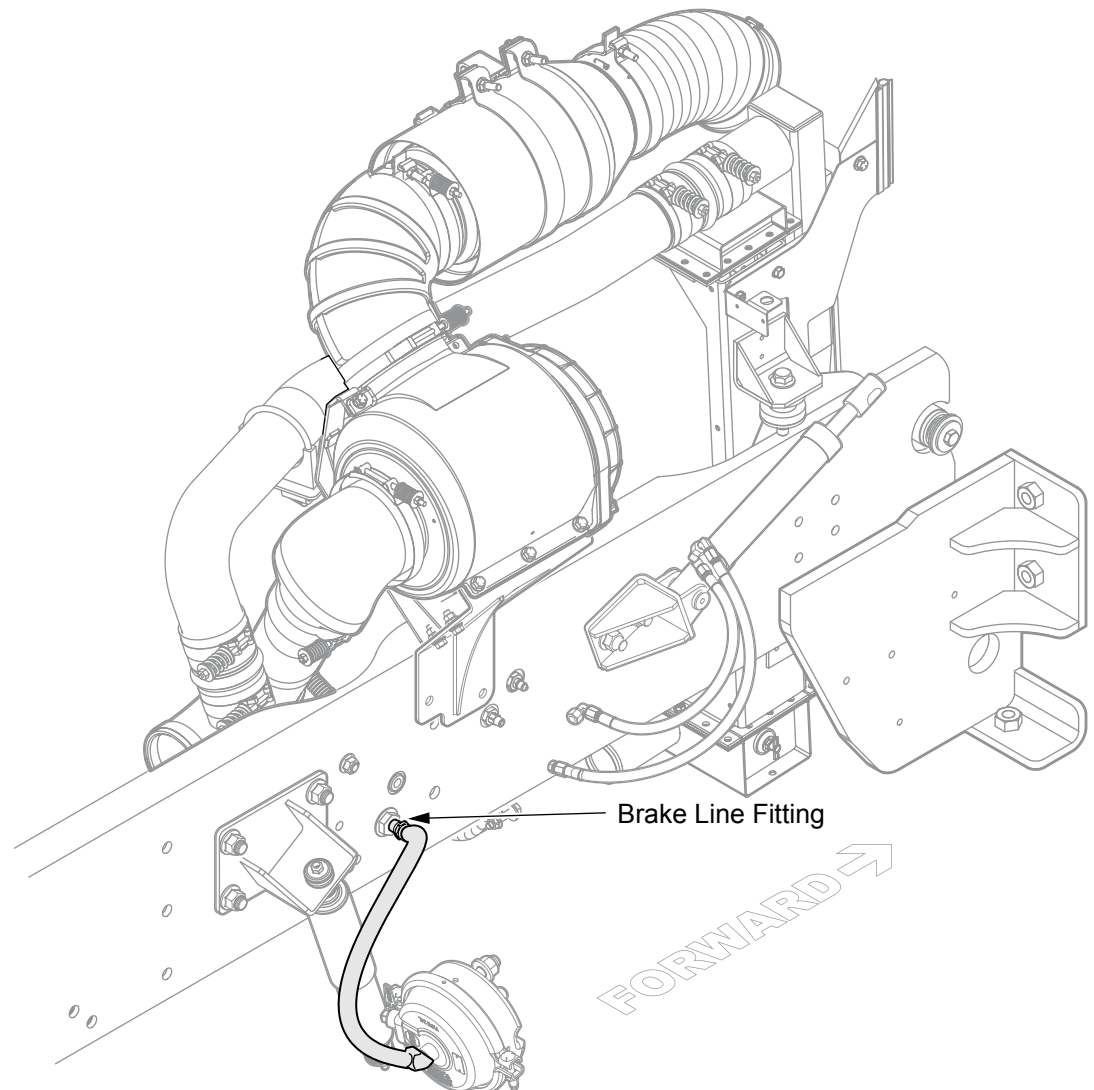

**Figure 4**

8. Using a 13/16" combination wrench, locate and disconnect the brake line (see Figure 4).
9. Using a 3/4" combination wrench, remove and discard the fitting to which the brake line was attached. Lay brake line to one side until ready for reinstallation (see Figure 4).

**Autocar Industries**  
551 South Washington Street  
Hagerstown, IN 47346  
877-973-3486



**Questions?** Visit the Autocar website at [www.autocartruck.com](http://www.autocartruck.com) and click the **Web-Link Direct** icon to request emergency service assistance.



## AUTOCAR INDUSTRIES SAFETY RECALL T-1101 NHTSA RECALL 11V-405

September, 2011

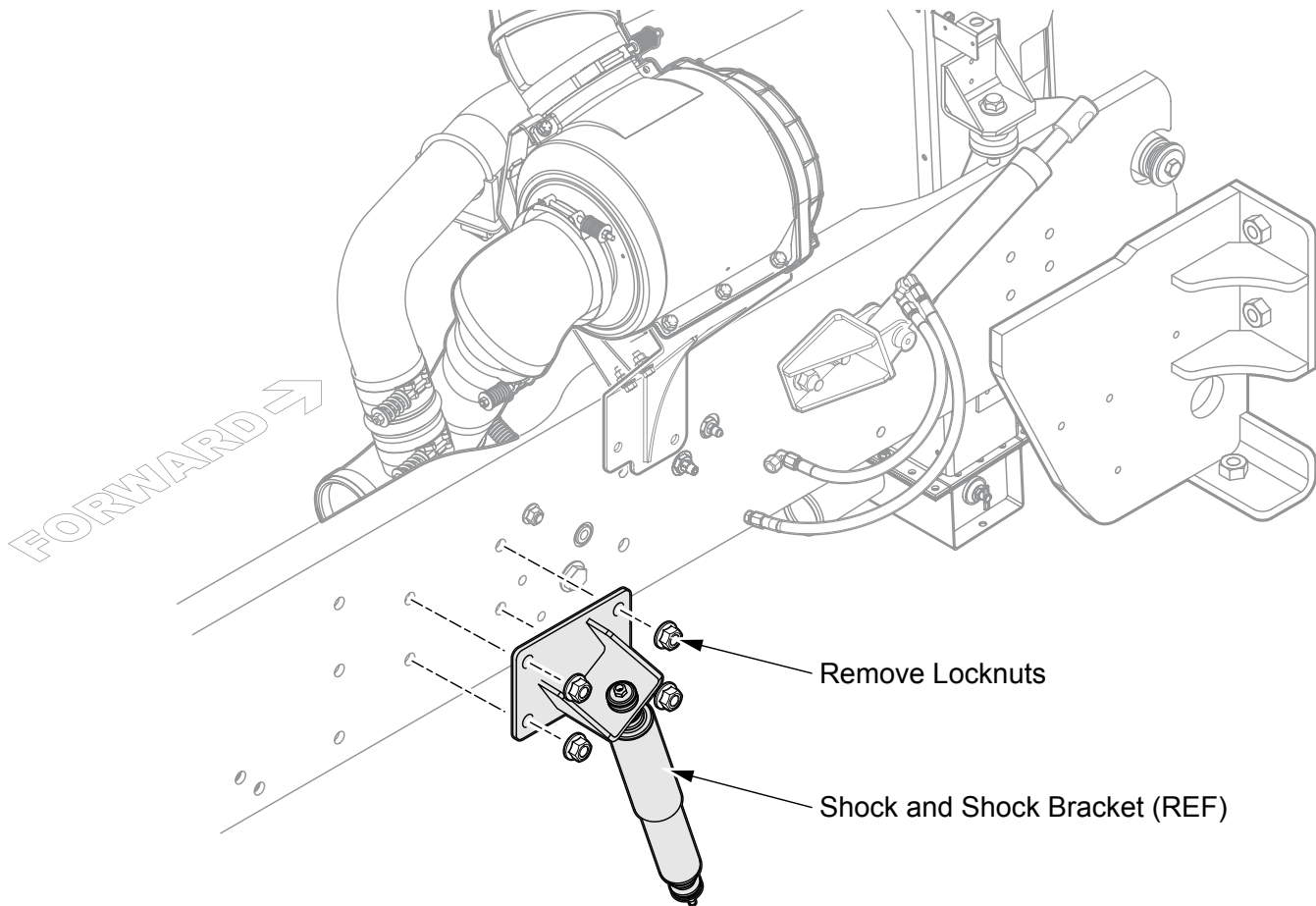

### Outboard Frame Rail View

**Figure 5**

10. Locate the right side shock bracket (see Figure 5).
11. Using a 1/2" drive 15/16" socket and a 15/16" combination wrench, remove and discard the four locknuts and the four bolts (not shown) (see Figure 5).

**Note:** *If the shock bracket was installed using huck bolts, huck cutters will be necessary for removal, then discard.*





## AUTOCAR INDUSTRIES SAFETY RECALL T-1101 NHTSA RECALL 11V-405

September, 2011

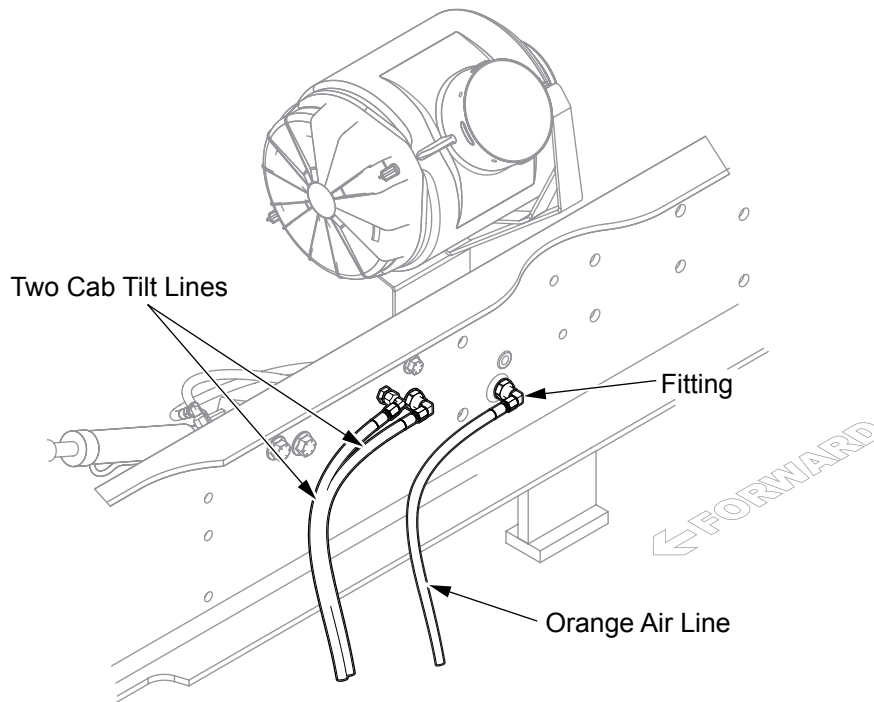

**Inboard Frame Rail View**

**Figure 6**

12. On the right side inner frame rail locate and disconnect the 1/2" orange air line. Reposition and lay to one side until ready for reinstallation (see Figure 6).
13. Using a 3/4" combination wrench, remove the fitting to which the orange air line was connected and set aside for reuse (see Figure 6).
14. Locate the two cab tilt lines on the left side inner frame rail (see Figure 6).
15. Using a 9/16" combination wrench, disconnect the two cab tilt lines (see Figure 6).





**AUTOCAR INDUSTRIES SAFETY RECALL T-1101**  
NHTSA RECALL 11V-405

September, 2011

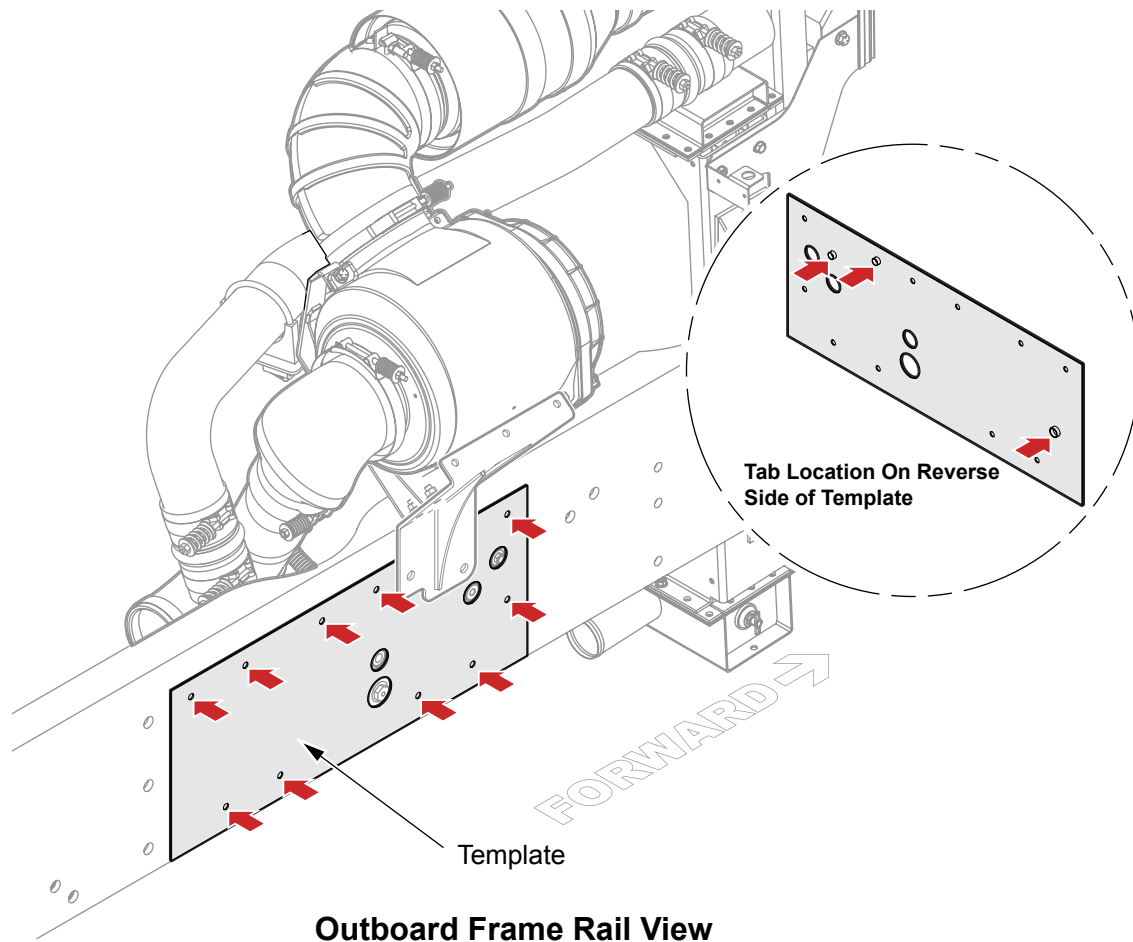

**Figure 7**

**16.** Using the template A4030328-001 that was supplied with the service kit S4030001K001, position the template on the outer right side frame rail as indicated (see Figure 7).

**Note:** The template has three tabs on the reverse side that will align with three existing bolt holes on the frame rail (see insert Figure 7).

**17.** Using a hammer and center punch, center punch the 10 holes on the template.

**Note:** Remove template before drilling holes and discard.

**18.** Using a 9/16" drill bit, drill all the holes that were marked in step 17.





## AUTOCAR INDUSTRIES SAFETY RECALL T-1101 NHTSA RECALL 11V-405

September, 2011

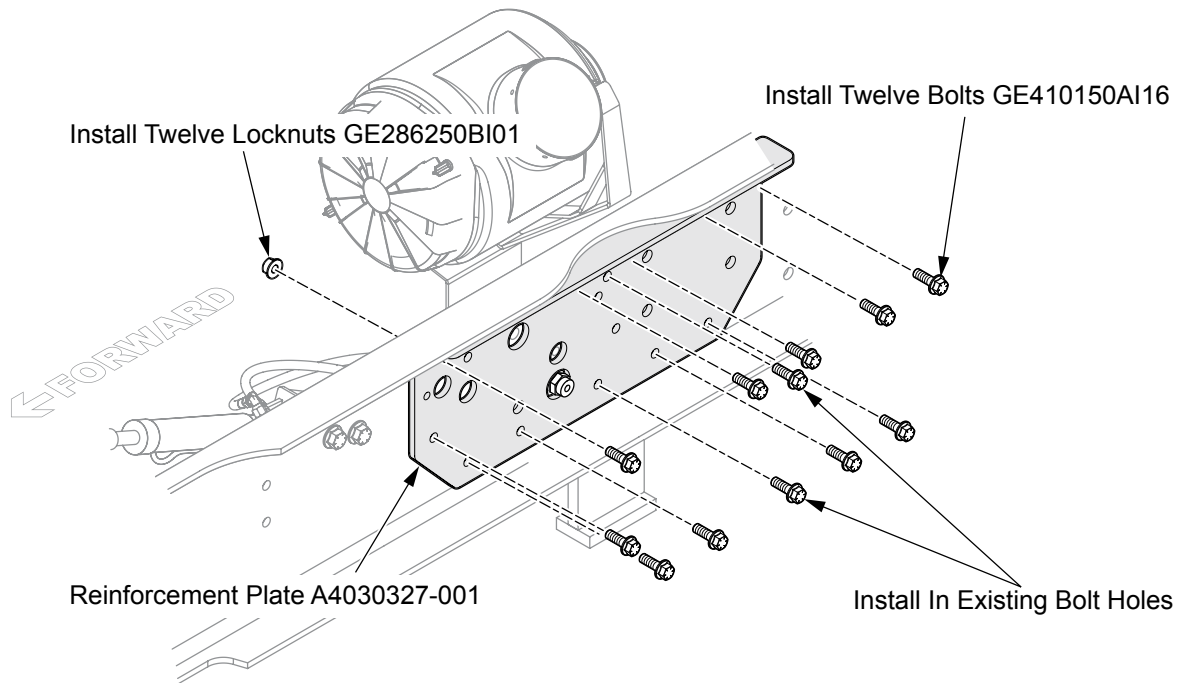

**Inboard Frame Rail View**

**Figure 8**

**Note:** Inspect the frame rail carefully. If one or more a cracks are found on the frame rail, they must be repaired by welding before continuing. For procedures on welding cracks on the frame rail, refer to "Repairing Cracks" beginning on page 14. If no cracks are present continue to the step 19.

**19.** Using a grinder, remove any debris and/or burrs from the inside of the frame rail in the area of installation and if applicable the finished weld must be ground completely smooth before installing the reinforcement plate A4030327-001.

**Note:** After the grinding is complete wipe down area and touch-up with paint as necessary.

**20.** Install the reinforcement plate to the inner frame rail and secure with the bolts GE410150AI16 and the locknuts GE286250BI01 that were supplied with the frame reinforcement hardware kit S4030001K002. Using a 1/2" drive 3/4" socket and a 1/2" drive torque wrench, tighten the bolts to 110 ft-lbs (150 N·m) of torque (see Figure 8).





## AUTOCAR INDUSTRIES SAFETY RECALL T-1101 NHTSA RECALL 11V-405

September, 2011

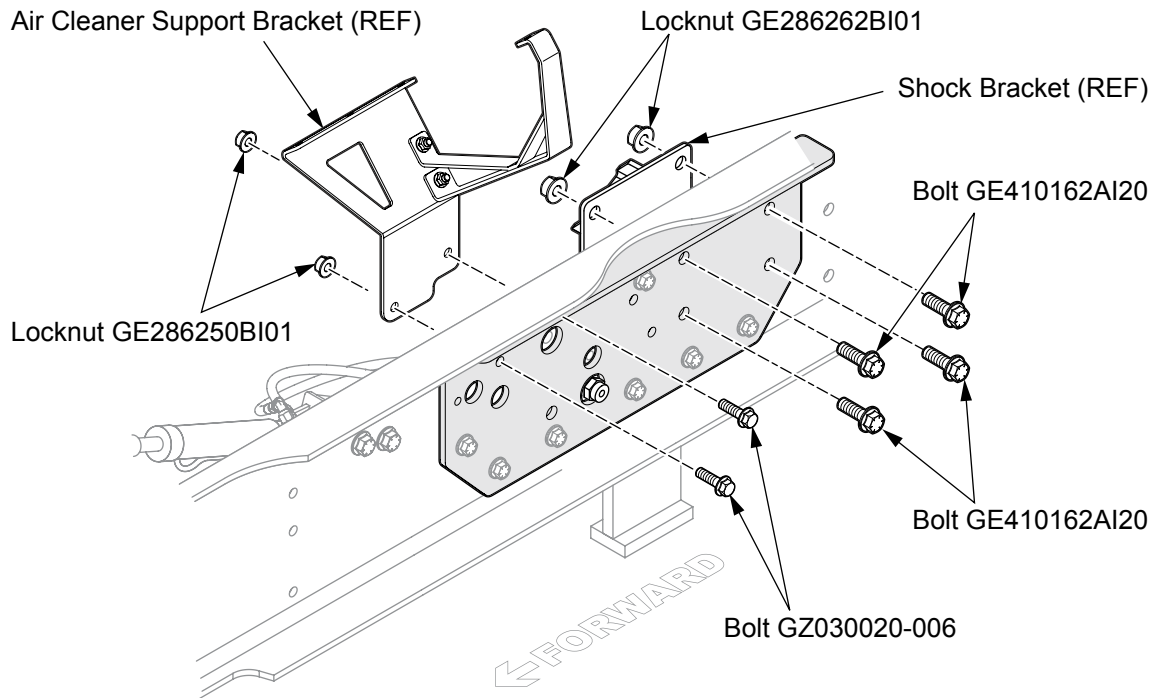

**Figure 9**

**21.** Using a 1/2" drive 3/4" socket and a 3/4" combination wrench, install the two locknuts GE286250BI01 and the two bolts GZ030020-006 supplied with the frame reinforcement hardware kit to secure the air cleaner support bracket to the frame rail. Tighten the bolts to 120 ft-lbs (160 N·m) of torque (see Figure 9).

**Note:** When reconnecting the air cleaner support bracket to the frame rail, check that the clearance between the newly installed reinforcement plate and the piping to the air cleaner is at least one inch.

**22.** Using a 1/2" drive 15/16" socket and a 1/2" drive torque wrench, install the four bolts GE410162AI20 and the four locknuts GE286262BI01 supplied with the frame reinforcement hardware kit to secure the shock bracket to the frame rail. Tighten the bolts to 215 ft-lbs (290 N·m) of torque (see Figure 9).

**23.** Using a 7/8" and a 3/4" combination wrench, install the new bulkhead fitting 3083117 that was supplied with the frame reinforcement hardware kit and tighten to 26 ft-lbs (35 N·m) of torque (see Figure 10).





## AUTOCAR INDUSTRIES SAFETY RECALL T-1101 NHTSA RECALL 11V-405

September, 2011

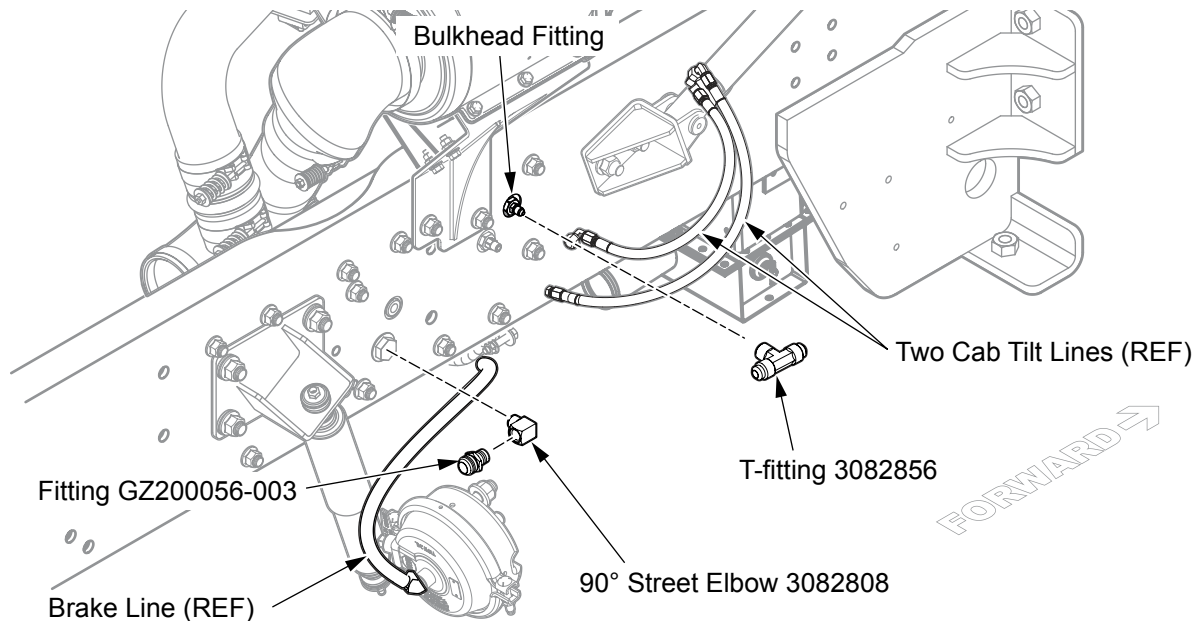

**Figure 10**

24. Using a 7/16" combination wrench, install the new T-fitting 3082856 that was supplied with the frame reinforcement hardware kit (see Figure 10).
25. Using a 9/16" combination wrench, reinstall the cab tilt lines to the new T-fitting (see Figure 10).
26. Using a 3/4" combination wrench, install the new 90° Street elbow 3082808 replacing the fitting previously removed in step 8 (see Figure 10).
27. Using a 3/4" combination wrench, install the new fitting GZ200056-003 replacing the fitting previously removed in step 9 (see Figure 10).
28. Using a 13/16" combination wrench, reattach the brake line that was disconnected in step 8 (see Figure 10).
29. Using a 9/16" combination wrench, reinstall the two cab tilt lines that were previously disconnected in step 15.
30. Lower the cab.
31. Operate the vehicle and check for hydraulic leaks and audible air leaks. Check the routing of the cab tilt air lines to ensure there is no abrasion. Check the cab tilt pump oil level. The oil level should be at the top of the reservoir. The pump reservoir should be filled with Dexron automatic transmission fluid (ATF) at all times.
32. The installation is now complete.





## AUTOCAR INDUSTRIES SAFETY RECALL T-1101 NHTSA RECALL 11V-405

September, 2011

### Repairing Cracks

#### **CAUTION**

*Welding on trucks can damage the vehicle electrical system/components due to the voltage and current spikes that normally occur when welding. It is preferable to avoid welding on an assembled truck, but if any structure on or in contact with the vehicle must be welded, follow the recommendations in this section. Never weld on the engine or engine components. Welding on the engine or components mounted on the engine can cause serious damage to the engine ECU.*

- Disconnect all cables from the alternator.
- Disconnect power to the component being welded.
- Disconnect both the positive (+) and negative (-) battery cables. Disconnect the negative cable first. Reconnect the positive cable first. Vehicles equipped with battery “quick disconnect” must still have the cables removed directly at the battery.
- Disconnect engine/starter ground from the chassis. This connection is located outside the left-hand frame rail in the engine compartment. Disconnect the power harness and vehicle interface harness at the engine (ECU).
- All vehicle electronic control modules must be disconnected. Modules include, but are not limited to, engine Electronic Control Unit (ECU), transmission ECU, anti-lock brake system ECU, vehicle electronic control module ECU, and any other component that uses the trucks electrical system to power the ECU.

- The negative or ground cable of the welding machine must be connected properly to the section of the vehicle for the modification and should be as close to the weld as possible (no more than 2 ft. (61 cm) from the part being welded).
- Do not connect the welder ground cable to the engine ECU or the ECU cooling plate.
- Welding cables should not be allowed to lay on/near or cross over any electrical wiring or electronic component during the welding procedure.
- To prevent damage during the welding process, take necessary precautions, including covering all electrical and air lines.

Using a grinder, bevel the edges to a 30 degree angle with a 1/16 in. (1.588 mm) land (see *Illustration 1*).

Grind away from the crack leaving a gap of approximately 1/16 in. (1.588 mm) (see *Illustration 1*).

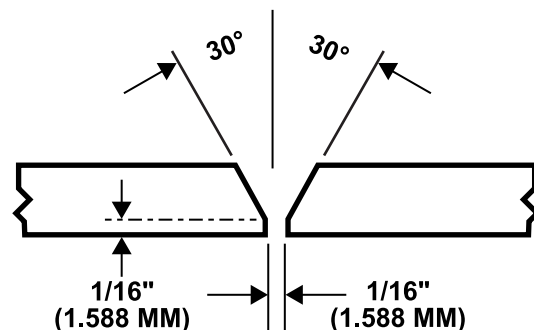

**Illustration 1**





## AUTOCAR INDUSTRIES SAFETY RECALL T-1101 NHTSA RECALL 11V-405

September, 2011

Using a 3/8" drill bit, drill a hole completely through the frame rail at the base of the crack (see *Illustration 2*).

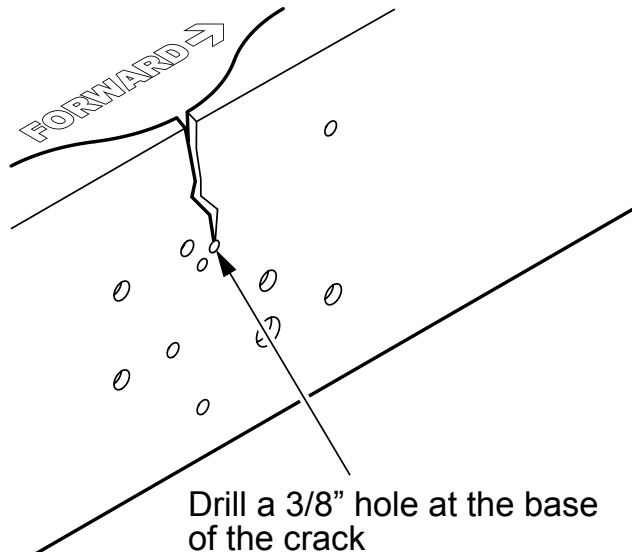

**Illustration 2**

Weld using a 3/32 in. (2.38 mm), E11018M welding rod with either direct or alternating current, reverse polarity and a positive electrode. Use the following voltage and current for either method:

**Volts — 21–24**

**Amperes — 70–120**

If the gap between parts is greater than 1/16 in. (1.588 mm), build up the edges by welding and grinding. Do not use fillers (see *Illustration 3*).

Place the last bead so as not to join plates but rather to join beads

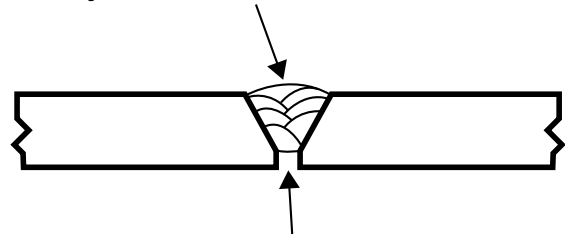

Check for undercut

**Illustration 3**

When assembling or joining parts by welding, the procedure must be completed so as to minimize distortion and shrinkage. For multiple pass welds, slag must be completely removed before proceeding with subsequent weld passes. Slag must be completely removed from finished welds, and the finished weld must be ground completely smooth on both sides of the joint. Cracks, porosity, overlaps and deep undercuts greater than 1/16 in. (1.588 mm), must be ground out and re-welded.

After the welding process has been completed and the welded parts have cooled, inspect wiring and components for possible shorts or damage which would allow the possibility of drawing excessive currents or cause short circuits when the batteries are reconnected.

After the welding process is complete continue the Frame Reinforcement at step 19, page 11.





## SAFETY RECALL BULLETIN

### AUTOCAR INDUSTRIES SAFETY RECALL T-1101 NHTSA RECALL 11V-405

September, 2011

516H4G9B5BH212301

516H4G9B5BH212749

516H4G9B0BH212772

516H4G9B6BH212923

516H4G9B8BH212924

516H4G9BXBH212925

516H4G9B3BH212944

516H4G9B5BH212945

516H4G9B5BH212993

516H4G9B7BH212994

516H4G9B1CH213074

516H4G9B3CH213075

516H4G9B1CH213169

**Autocar Industries**  
551 South Washington Street  
Hagerstown, IN 47346  
877-973-3486



**Questions?** Visit the Autocar website at [www.autocartruck.com](http://www.autocartruck.com) and click the **Web-Link Direct** icon to request emergency service assistance.