



Diavel License Plate Holder Fixing System  
Models: Diavel MY2011 (all versions)  
Recall Bulletin RCL-11-002

Date: Tuesday, July 12th, 2011  
To: Dealer Principal, Service Manager, North American Dealer Network  
From: Austin Gray, Technical Director; Jonathan LaForte, Technical Manager

---

**Important:** All Dealer Principals, Service Managers, and Parts Managers should read and initial this notice.

Dear Service Manager,

This notice is sent to you in accordance with the requirements of the National Traffic and Motor Vehicle Safety Act.

NHTSA Campaign I.D. Number: 11V-336  
Transport Canada Safety Recall I.D. Number: 2011-238

**Description of the technical problem:**

- On the motorcycles indicated above, the chain guard was produced with brass inserts that could deform over time resulting in the possible loosening of number plate holder retaining screws on the rear swing-arm.

**Description of the technical problem solution:**

- On affected bikes, install the new chain guard with steel insert, Part No 44610242A, and tighten the number plate holder retaining screws to the new torque of 40Nm $\pm$ 10%.





Diavel License Plate Holder Fixing System  
 Models: Diavel MY2011 (all versions)  
 Recall Bulletin RCL-11-002

**Criteria for application of the technical solution on circulating motorcycles:**

- This solution has been implemented in the production line starting from the frame numbers shown below:

MODEL	FRAME NO.
Diavel MY2011	ZDM13BLW0BB005296

**Affected VIN range requiring application of the technical solution:**

INVOLVED BIKES – Diavel		
COUNTRY VERSION	From frame no.	To frame no.
CAL	ZDM13BLW5AB000027	ZDM13BLW6BB005262
CDN	ZDM13BLW2BB000696	ZDM13BLW6BB005155

**Criteria for application of the technical solution on circulating motorcycles:**

- For the designated frame numbers in the attached VIN list the motorcycles must be updated.

**Customer notification:**

- Ducati North America, Inc. will notify all known owners of affected vehicles directly by First Class mail. A sample copy of the owner notification letter is enclosed for your information.

**Vehicle allocation:**

- Prior to owner notification, we will furnish you a list of affected vehicles (See attached Affected VIN List)

**Limitation on sale or lease of certain vehicles:**

- Section 154(d) of National traffic and Motor Vehicle Safety Act of 1996 mandates that dealers correct, prior to sale or lease, any vehicle which contains a defect relating to motor vehicle safety. It is therefore mandatory that any vehicle in your inventory affected by this recall be corrected prior to sale or lease.

**Auto-ship replacement part:**

- No auto-shipment is required.



Diavel License Plate Holder Fixing System  
Models: Diavel MY2011 (all versions)  
Recall Bulletin RCL-11-002

**Repair instructions:**

Please proceed as follows on all affected motorcycles:

1. Remove the number plate light cable (2) retaining tie (3) from the chain guard (1);

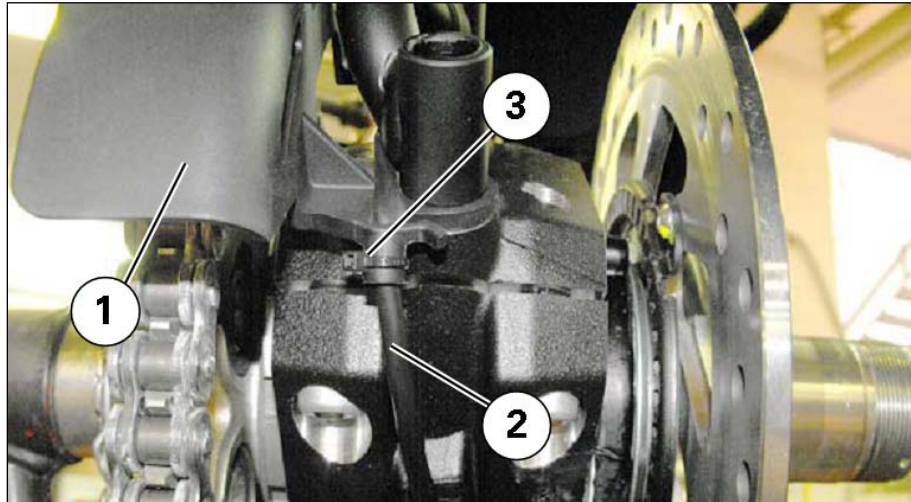

2. Remove the number plate holder (5) retaining screws (4).

Then, remove the chain guard (1) from the swing-arm.

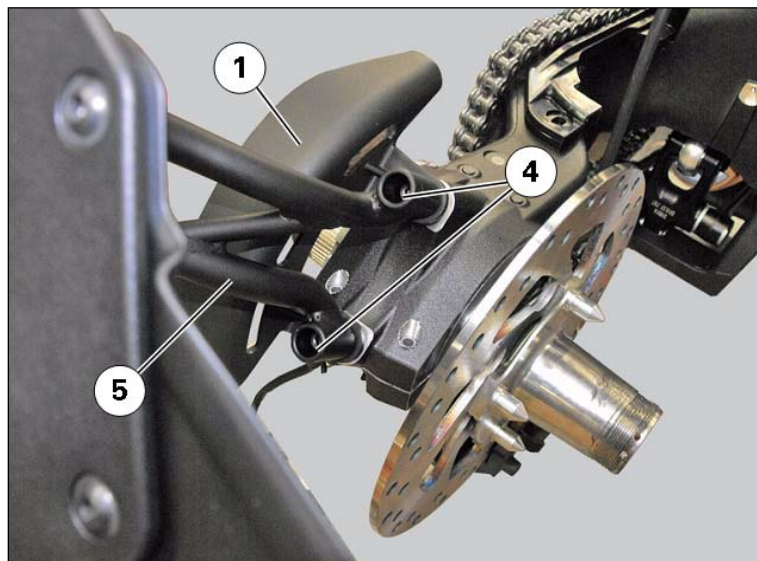



Diavel License Plate Holder Fixing System  
Models: Diavel MY2011 (all versions)  
Recall Bulletin RCL-11-002

**NOTE**

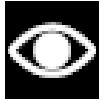

To loosen the retaining screws (4) from the rear swing-arm number plate holder we recommend using a 6 mm Allen socket with maximum stem diameter of 10 mm and stem length of approximately 30 mm (available at any tool supplier). Utilizing such a tool, it is not necessary to remove the rear wheel.

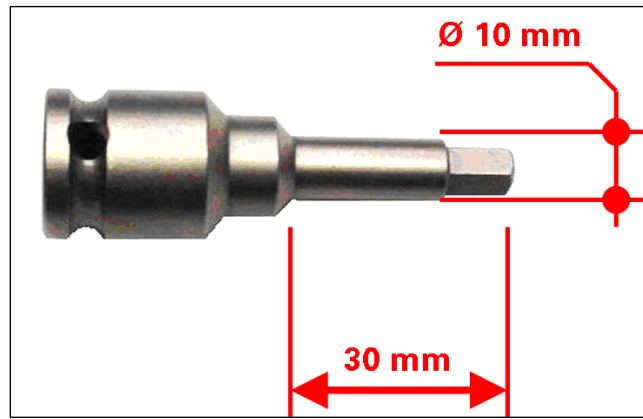

3. Place the new chain guard Part No. 44610242A on the number plate holder paying attention not to press the number plate light cable (2) between the number plate holder (5) and the chain guard (1).

Place the number plate light cable (2) in its seat (6) on the chain guard.

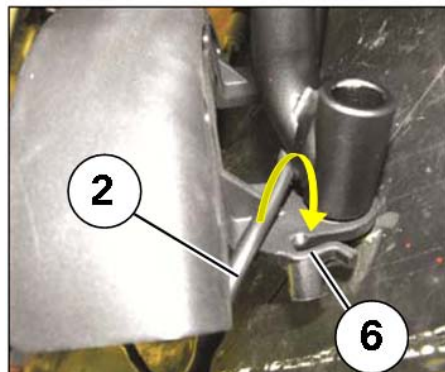



Diavel License Plate Holder Fixing System  
Models: Diavel MY2011 (all versions)  
Recall Bulletin RCL-11-002

- Place the number plate holder (5) on the rear swing-arm and start the number plate holder (5) retaining screws (4) with pre-applied thread locker.

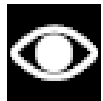

**NOTE**

Reuse the previously removed screws (4) after clearing the old thread locker from their threads. Then, apply **LOCTITE 243**.

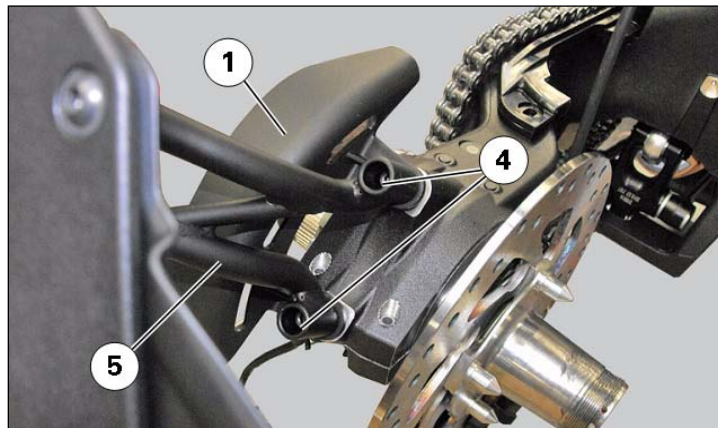

- Tighten the screws (4) to a torque of 40 Nm  $\pm$  10% in a 1-2-1-2 sequence.

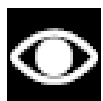

**NOTE**

For proper tightening of the screws, set them to an initial torque of 25 Nm and only then tighten the screws to a final torque of **40 Nm  $\pm$  10%** using a 1-2-1-2 sequence.

- Fit a new number plate light cable (2) retaining tie (3) on the chain guard (1).

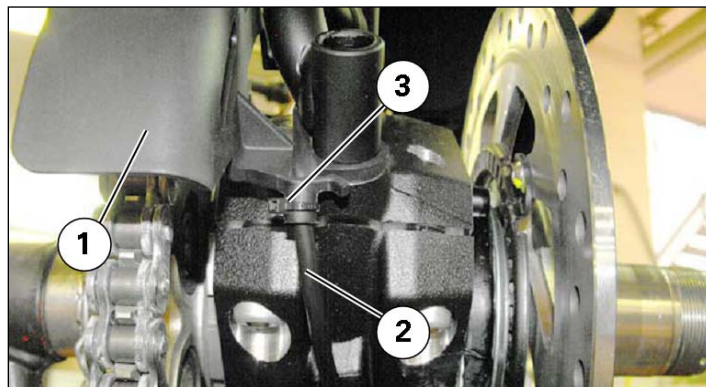



Diavel License Plate Holder Fixing System  
Models: Diavel MY2011 (all versions)  
Recall Bulletin RCL-11-002

**Spare parts:**

- Spare parts part numbers are:

Description	Part No.
CHAIN GUARD	44610242A

**Special tools:**

No special tools are required.

**Time allowance and reimbursement procedure:**

A warranty claim must be submitted in ARCO using the following codes:

Sub-group	2
Fault no.	080
Safety	A
Campaign	<i>TBD</i>
Product line	23
Subject	2
Labor Operation (24 mins)	009

Mark the chain guard (Part No. 44610242A) as the part that generated the fault.

**Please note that it is necessary to enter each repair under warranty as an individual warranty claim, using the specified fault and labor codes. This process ensures that this recall campaign has been actually completed and will be correctly reported to government agencies.**

**Campaign authorization:**

Ducati North America, Inc. will mail a notification letter to all known owners. If a customer does not present this notification letter, it is important that you confirm the eligibility for recall status on the ORACLE portal (Dealer Bikes -> Recall Campaign), before you commence work. Reimbursement requests for duplicate recall campaign repairs will not be accepted.

**Dealer obligation:**

This program is designed to complete the necessary repairs and to achieve owner satisfaction. Therefore, we ask you to take prompt and courteous action in accordance with these directives. Please provide a copy of this communication to every person in your dealership who has recall-related responsibilities.

Thank you for your cooperation.  
Ducati North America, Inc.  
Service Department



Diavel License Plate Holder Fixing System  
Models: Diavel MY2011 (all versions)  
Recall Bulletin RCL-11-002

*Sample of Customer Letter*

## IMPORTANT SAFETY RECALL

Date

Name

Address

City, St, Zip

VIN#

**Subject:       Ducati Motorcycles:  
                  M.Y. 2011 Diavel (all versions)**

NHTSA Safety Recall Number: 11V-336

Transport Canada Safety Recall I.D. Number: 2011-238

Dealer Bulletin: RCL-11-002

Dear Ducati Owner,

This notice is sent to you in accordance with the requirements of the National Traffic and Motor Vehicle Safety Act & Canada Motor Vehicle Safety Act.

Ducati Motor Holding S.P.A. has decided that a defect that relates to motor vehicle safety exists in certain model year 2011 Diavel (all versions) motorcycles. Our records indicate that you are the owner of a Ducati motorcycle affected by this safety recall campaign. Please take the time to read this letter and help us take the appropriate steps to ensure that your vehicle is operating properly.

### **Summary of Procedure:**

Ducati Motor Holding S.P.A. has determined that during production, the chain guard installed was manufactured with brass inserts that could deform over time. This could result in the possible loosening of license plate holder retaining screws on the rear swing-arm. This situation could cause the license plate holder to possibly become loose during normal operation of the motorcycle resulting in damage to the motorcycle and a potential hazard to the rider. Significant loosening of the license plate holder could interfere with the motorcycle's rear wheel rotation and thereby increase the risk of a crash.

To correct this condition, your authorized Ducati dealer will replace the chain guard with an updated version, manufactured with steel inserts. The Dealer will perform this replacement at no cost to you for parts and labor.



Diavel License Plate Holder Fixing System  
Models: Diavel MY2011 (all versions)  
Recall Bulletin RCL-11-002

We request that you contact your authorized Ducati dealer and schedule an appointment, so that the required service can be performed without delay. To locate your nearest authorized Ducati dealer, please go to [www.ducati.com](http://www.ducati.com) and select the "dealer locator" or you may call toll free from the U.S. 800-231-6696. Your dealer can complete the required service in under an hour, if you have an appointment. If your dealer has a number of vehicles awaiting service, additional time may be required.

Federal regulations require that any lessor receiving this recall notice must forward a copy of this notice to the lessee within ten days.

**Service Problem Help:**

If you believe that your dealer has failed or is unable to perform the service within a reasonable period of time, please write to:

Ducati North America, Inc.  
Attn: Customer Service  
10443 Bandley Drive  
Cupertino, CA 95014

If you still cannot obtain satisfaction, you may file a complaint with:

**USA Customers:**

Administrator  
National Highway Traffic Safety Administration  
1200 New Jersey Avenue, SE  
Washington, D.C. 20590  
Or call toll-free hotline at 1-888-327-4236  
(TTY 1- 800-424-9153), or go to [HTTP://WWW.SAFERCAR.GOV](http://WWW.SAFERCAR.GOV).



Diavel License Plate Holder Fixing System  
Models: Diavel MY2011 (all versions)  
Recall Bulletin RCL-11-002

**TREADACT CUSTOMER REIMBURSEMENT PLAN**

If you have paid for the repair described in the attached letter, and you would like to be considered for reimbursement, please contact your authorized Ducati dealer. Expenses from repair facilities outside of the authorized Ducati dealer network will be considered; however, the procedure must meet Ducati North America's standards and use Ducati original replacement parts.

Your authorized Ducati retailer will request a copy of your owner notification letter, as well as, a copy of your previously paid invoice. They inspect the vehicle, if still in your possession, prior to submitting a claim on your behalf to Ducati North America, Inc. for reimbursement.

Please note the following:

Only a repair subject of this safety recall campaign is reimbursable. Ducati North America, Inc will not reimburse consequential expenses such as towing, rental, accommodations, and damage repairs.

Ducati North America, Inc. will not reimburse for prior repairs that did not utilize original Ducati parts.

We recommend that your authorized Ducati dealer be your primary contact on this issue. We anticipate that your authorized Ducati dealer will be able to answer any questions that you may have regarding your qualifications for reimbursement of a previous repair; however, our Customer Relations Dept. may be contacted at 408-253-0499 for any special assistance required.

We regret any inconvenience to you from this action; however, your safety and satisfaction are important to us. We request that you bring your Ducati motorcycle to your nearest authorized Ducati dealer at your earliest convenience.

Thank you for riding Ducati.

Sincerely,

Ducati North America  
Service Department