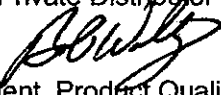

TOYOTA CUSTOMER SERVICES

Volume: XVIII
Number: TC11-016
Date: 4/27/2011
 Action
 Retain
 Information

INTEROFFICE MEMORANDUM

To: All Region/Private Distributor General Managers/Vice Presidents

From: Bob Waltz, 
Vice President, Product Quality and Service Support

Subject: Safety Recall B0A – *Remedy Parts Available*
Certain 2004 – 2006 model year Highlander/Highlander HV
Driver's Side Floor Carpet Cover and Retention Clips

As previously announced, on Thursday February 24, 2011, Toyota filed a Defect Information Report (DIR) with the National Highway Traffic Safety Administration (NHTSA) informing the agency of our intent to conduct a voluntary Safety Recall on certain 2004 – 2006 model year Highlander/Highlander HV vehicles to replace the driver's side Floor Carpet Cover and Retention Clips.

Toyota has completed parts preparation and will now begin mailing the remedy owner letter.

Background

In certain 2004 through 2006 model year Highlander and Highlander HV vehicles, if the forward retention clip used to secure the driver's side Floor Carpet Cover, which is located in front of the center console, is not installed properly, the cover may lean toward the accelerator pedal and interfere with the accelerator pedal arm. If this occurs, the accelerator pedal may temporarily become stuck in a partially depressed position rather than return to the idle position. An accelerator pedal temporarily stuck in a partially depressed position may increase the risk of a crash.

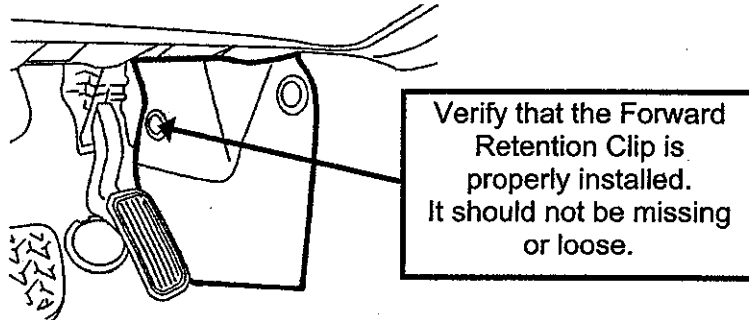

Remedy

Toyota will replace the Driver's side Floor Carpet Cover and Retention clips with newly designed parts. The new Floor Carpet Cover has an additional tab which extends beyond the travel of the accelerator pedal arm, so as not to interrupt the movement of accelerator pedal arm even if the cover is leaning.

The following vital information is provided to inform you and your dealers of the remedy owner notification phase of this campaign and your degree of involvement.

1. Dealer Letter Mailing Date

The attached dealer letter will be sent to all Toyota dealers in late April, 2011.

2. Owner Letter Mailing Date

Toyota has completed parts preparation and will begin to notify owners of the Remedy Phase in early May, 2011 approximately 1 week after the dealer communication. The owner notification will be mailed in quantities consistent with parts availability and repair capacity.

3. Dealer/District Summary Reports

We have enclosed the following Safety Recall B0A Summary Reports in the Region/Private Distributor (PD) Service Manager/Customer Service Operations Manager/Director of Service package:

- Region/PD Summary Report that provides an overview of the entire Region/PD for this Safety Recall.
- A District Summary Report that indicates the number of covered vehicles per dealership in each district for this Safety Recall.

4. Number and Identification of Involved Vehicles

There are approximately 397,000 Toyota Highlander and Highlander HV (Certain 2004 – 2006 Model Year) Vehicles involved in this Safety Recall.

Please note that only owners of the covered vehicles will be notified. If a dealer is contacted by an owner who has not yet received the notification, please instruct the dealer to **verify coverage by confirming through Dealer Daily/TIS**. Dealers should perform the procedure as outlined in the Technical Instructions located on TIS.

5. Manual Allocation Control (MAC) Parts Ordering Process.

Orders can be placed through your dealership's facing PDC. The kits have been placed on Dealer Ordering Solutions and will be systematically released daily based on dealer ordering criteria. Each dealer has receive specific dealer ordering criteria in an email from their facing PDC Manager based on Repair Order Volume * PDC Affected UIO. Therefore, it is vital that each dealership work with both Parts and Service to immediately file Safety Recall claims and coordinate appropriate kit orders.

Additional Part Ordering information can be found in the dealer communication and Special Activity Weekly MAC Report.

6. Media Contacts

It is imperative that all media contacts (local and national) receive a consistent message. In this regard, all media contacts must be directed to Brian Lyons (310) 468-2552 in Toyota Corporate Communications. (Please do not provide this number to customers. Please provide this contact to only media associates.)

7. Customer Contacts

A Q&A has been attached for your use in the event you receive a customer contact. If a customer has further questions, please direct the inquiry to the Toyota Customer Experience Center at 1-800-331-4331.

The attached Dealer Notification Letter contains additional details.

Please review this interim notification with your staff to assure that all relevant personnel have been briefed regarding this subject.

Thank you for your cooperation.

cc: Region/Private Distributor Assistant General Managers
 Region/Private Distributor Customer Service Operations Managers
 Region/Private Distributor Service Managers/Directors/VPs
 Region/Private Distributor Parts Managers/Directors/VPs
 Region/Private Distributor Customer Services Field Managers
 Region/Private Distributor Technical Services and Training Managers
 Region/Private Distributor District Service and/or Parts Managers
 Region/Private Distributor Customer Relations Managers
 Region/Private Distributor PDC Managers
 Region/Private Distributor Field Technical Specialists
 Region/Private Distributor Service Training Specialists
 Region/Private Distributor Vehicle Operations Managers
 All NAPC General Managers
 All TMS Sales Administration Managers
 All TMS Product Quality & Service Support Managers
 All Field Product Engineers

G. Borst	N. Fein	J. Lentz	S. Sugawara
R. Broughman	F. Fontanella	E. Matsuda	M. Templin
G. Bryan	H. Fukui	M. Michels	J. Tetherow
W. Burns	S. Haag	T. Morrison	P. Turner
D. Camden	J. Hanson	T. Nakagami	K. Ura
B. Carter	K. Higgins	D. Pettitt	P. Uribe
G. Christoff	C. Hostetter	R. Pflughaupt	A. Vaish
J. Colon	M. Hosoe	C. Reynolds	R. Waltz
B. Cooper	Y. Inaba	C. Roberts	S. Watanabe
R. Daly	K. Ito	R. Sakai	S. Yamaguchi
F. Davidson	M. King	M. Setta	M. Yamanami
T. Doi	K. Kusakawa	A. Smith	H. Yoshihashi
D. Esmond	M. Kosugi	R. Specht	D. Zellers
W. Fay	J. Lang	J. Stempkowski	

To: All Toyota Dealer Principals, Service Managers, Parts Managers

Subject: Safety Recall B0A – *Remedy Parts Available*
Certain 2004 – 2006 model year Highlander/Highlander HV
Driver's Side Floor Carpet Cover and Retention Clips

As previously announced, on Thursday February 24, 2011, Toyota filed a Defect Information Report (DIR) with the National Highway Traffic Safety Administration (NHTSA) informing the agency of our intent to conduct a voluntary Safety Recall on certain 2004 – 2006 model year Highlander/Highlander HV vehicles to replace the driver's side Floor Carpet Cover and Retention Clips.

Toyota has completed parts preparation and will now begin mailing the remedy owner letter.

Background

In certain 2004 through 2006 model year Highlander and Highlander HV vehicles, if the forward retention clip used to secure the driver's side Floor Carpet Cover, which is located in front of the center console, is not installed properly, the cover may lean toward the accelerator pedal and interfere with the accelerator pedal arm. If this occurs, the accelerator pedal may temporarily become stuck in a partially depressed position rather than return to the idle position. An accelerator pedal temporarily stuck in a partially depressed position may increase the risk of a crash.

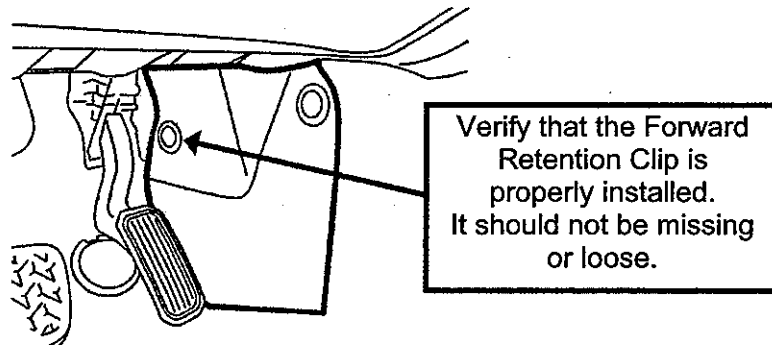

Remedy

Toyota will replace the Driver's side Floor Carpet Cover and Retention clips with newly designed parts. The new Floor Carpet Cover has an additional tab which extends beyond the travel of the accelerator pedal arm, so as not to interrupt the movement of accelerator pedal arm even if the cover is leaning.

The following vital information is provided to inform you and your staff of the *Remedy* owner notification phase of the campaign and your degree of involvement.

1. Owner Notification Mailing Date

Toyota has completed parts preparation and will begin to notify owners of the Remedy Phase in early May, 2011 approximately 1 week after the dealer communication. The owner notification will be mailed in quantities consistent with parts availability and repair capacity.

2. Dealer/Owner Lists

Summary Reports, containing the number of covered vehicles in your dealership's primary marketing area, have been enclosed in the dealer package. (Please verify eligibility by confirming through Dealer Daily or TIS prior to performing repairs.)

3. Vehicles in Dealer Stock

As required by Federal law, dealers are not to deliver any new vehicles in their inventory that are involved in a Safety Recall unless the defect has been remedied. Vehicle Safety Recall completion can be verified through TIS.

4. Number and Identification of Covered Vehicles

There are approximately 397,000 Toyota Highlander/Highlander HV (Certain 2004 – 2006 Model Year) vehicles covered by this Safety Recall.

MODEL	WMI	MY	VDS	START	FINISH
HIGHLANDER	JTE	2004	DD21A	0073058	0105659
			DP21A	0001005	0043214
			ED21A	0025894	0031832
			EP21A	0001045	0067233
			GD21A	0073656	0105684
			GP21A	0001006	0043210
		2005	HD21A	0025363	0033057
			DD21A	0105687	0132243
			DP21A	0043215	0091384
			ED21A	0033309	0039278
			EP21A	0067234	0136405
			GD21A	0105182	0132242
		2006	GP21A	0042673	0091386
			HD21A	0033060	0040125
			HP21A	0118918	0118918
			DD21A	0132256	0155324
			DP21A	0091388	0126213
			ED21A	0040139	0044652
HIGHLANDER HV	JTE	2005	EP21A	0136406	0186757
			GD21A	0132244	0155327
		2006	GP21A	0090882	0126215
			HD21A	0040128	0045716
			HP21A	0165464	0186758
			EW21A	0001002	0001004
DW21A	0001003	0016407			
2006	EW21A	0001009	0033818		
	GW21A	0001541	0013007		
			HW21A	0001275	0020710

Please note that only owners of the covered vehicles will be notified. If a dealer is contacted by an owner who has not yet received the notification, please **verify coverage by confirming through Dealer Daily/TIS**. Dealers should perform the procedure as outlined in the Technical Instructions located on TIS.

A UIO matrix by state is provided to inform your dealership of the number of affected vehicles in your state.

STATE	UIO
AK	644
AL	4,479
AR	2,210
AZ	7,114
CA	62,677
CO	7,799
CT	6,350
DC	615
DE	1,288
FL	26,018
GA	12,149

STATE	UIO
HI	2,873
IA	2,852
ID	1,322
IL	16,037
IN	4,645
KS	2,812
KY	4,943
LA	4,455
MA	18,087
MD	13,049
ME	1,992

STATE	UIO
MI	5,059
MN	6,663
MO	5,055
MS	1,820
MT	982
NC	14,096
ND	444
NE	1,510
NH	3,255
NJ	14,564
NM	2,011

STATE	UIO
NV	3,479
NY	21,687
OH	10,069
OK	2,445
OR	5,021
PA	16,282
RI	1,914
SC	6,332
SD	571
TN	6,086
TX	21,484

STATE	UIO
UT	2,350
VA	15,747
VT	1,191
WA	8,892
WI	6,507
WV	1,464
WY	538

5. Remedy Procedures

For additional repair information please refer to TIS.

Conduct all applicable, non-completed Safety Recall and Service Campaigns on the vehicle during the time of appointment.

6. Parts Ordering

Orders can be placed through your dealership's facing PDC. The kits have been placed on Dealer Ordering Solutions and will be systematically released daily based on dealer ordering criteria.

Part Number	Part Description	Quantity
04001-1340E	Cover Kit, Floor Carpet, CTR LH* (Ivory)	1
04001-11348	Cover Kit, Floor Carpet, CTR LH* (Gray)	1
*The kit above includes the following parts: 58534-xxxxx-xx – Floor Carpet Cover – Qty 1 90467-06020-C0 – Retention Clips – Qty 2		

IMPORTANT PARTS ORDERING REMINDER

Effective March 1, 2009, Safety Recall, Service Campaign (SSC/LSC) and Customer Support Program (CSP) parts do not earn Parts Return Credit Accrual and are not returnable under the Monthly Return Program. It is recommended that you order these parts based on appointments or immediate customer needs using a "Sell One-Buy One" ordering pattern. Please refer to PANT Bulletin 09-12 for additional details.

Each dealer will receive specific dealer ordering criteria in an email from their facing PDC Manager based on Repair Order Volume * PDC Affected UIO. Therefore, it is vital that each dealership work with both Parts and Service to immediately file Safety Recall claims and coordinate appropriate kit orders. A sample of the Parts Allocation Report has been attached below for your reference.

TOYOTA

Parts Allocation Report

99999
SAMPLE TOYOTA of NOWHERE

The below matrix provides information for parts managed by NAPO Dealer Ordering Solution (DOS) and illustrates updates to your current daily allocation quantities. Parts shipments, arrivals and inventory quantities at your local PDC will change daily as parts are received and shipped from NAPO Suppliers. Therefore, your daily allocation quantity is subject to change based on the parts in-stock availability as well as in-transit inventory to your facing PDC. This report is provided as needed when daily allocation changes for DOS parts.

Parts with recent changes will be illustrated from top to bottom with the most recent effective date.

If you have any questions or concerns, please contact your facing PDC Customer Support Leader, John Q Sample at (999) 999-9999.

Part Number	Total Allocation Quantity	Allocation Quantity	Allocation Frequency	Total Allocation Shipped	Total Allocation Remaining	Effective Date

7. Warranty Processor Instructions

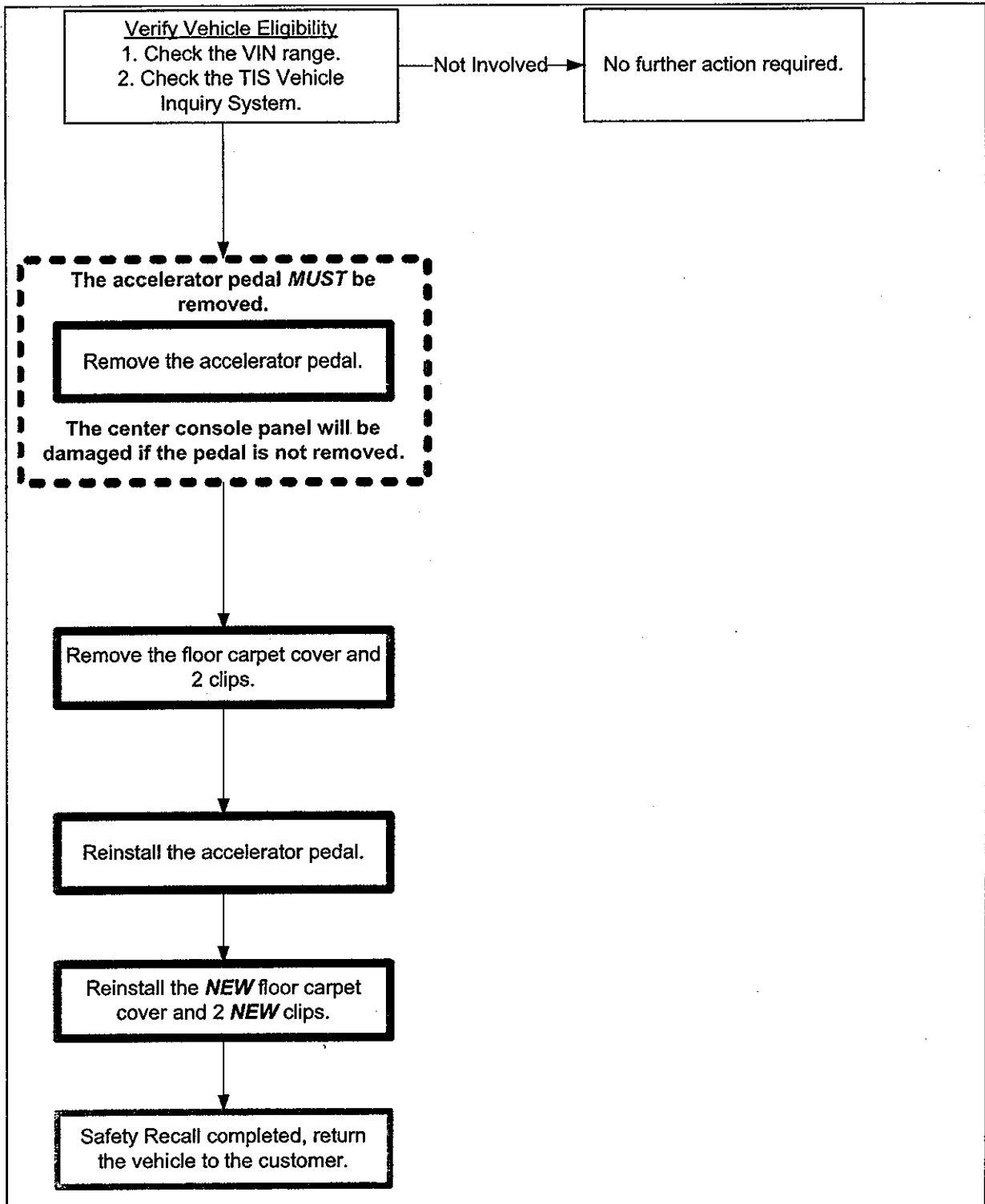

Operation Codes:

Safety Recall	Op. Code	Description	Flat Rate Hour
B0A	1526B1	Replace the Floor Carpet Cover and Retention Clips	0.3 hr/vehicle

- The flat rate times include 0.1 hours for administrative cost per unit for the dealership.

The interim inspection procedure, B1A, is now superseded by Safety Recall B0A. All B1A procedures must be completed by April 30, 2011. All claims for B1A must be submitted no later than May 31, 2011.

8. **Media Contacts**

- If you are a dealership associate and have any questions, please contact your District Service/Parts Manager.
- ***In the event you are contacted by the News media***, it is imperative that all media contacts (local and national) receive a consistent message. Please direct all media contacts to Brian Lyons (310) 468-2552, in Toyota Corporate Communications. (Please do not provide these numbers to customers or call if you are a dealer associate. Please provide these contacts to only media representatives.)

9. **Customer Contacts**

- A Q&A has been attached for your use in the event you receive a customer contact. If a customer has further questions, please direct the inquiry to the Toyota Customer Experience Center at 1-800-331-4331.

Please review this entire package with your Service and Parts staff to familiarize them with the proper step-by-step procedures required to implement this Safety Recall.

Thank you for your cooperation.
TOYOTA MOTOR SALES, U.S.A., INC.



Safety Recall Campaign B0A – Remedy Notice
Certain 2004 – 2006 model year Highlander/Highlander HV
Driver's Side Floor Carpet Cover and Retention Clips – Q&A

Q1: What is the condition?

A1: In certain 2004 through 2006 model year Highlander and Highlander HV vehicles, if the forward retention clip used to secure the driver's side Floor Carpet Cover, which is located in front of the center console, is not installed properly, the cover may lean toward the accelerator pedal and interfere with the accelerator pedal arm. If this occurs, the accelerator pedal may temporarily become stuck in a partially depressed position rather than return to the idle position. An accelerator pedal temporarily stuck in a partially depressed position may increase the risk of a crash.

Q1a: How many retention clips secure the Floor Carpet Cover?

A1a: There are two retention clips, a forward one and a rearward one.

Q2: What is Toyota going to do?

A2: Toyota has completed parts preparations and will now begin mailing remedy owner letters.

Toyota will replace the Driver's side Floor Carpet Cover and Retention clips with newly designed parts. The new Floor Carpet Cover has an additional tab which extends beyond the travel of the accelerator pedal arm, so as not to interrupt the movement of accelerator pedal arm even if the cover is leaning. This will be performed at no charge to the vehicle owner.

Q3: Are there any other Toyota or Lexus models covered by this Safety Recall?

A3: In addition to the Highlander/Highlander HV vehicles, there are approximately 372,000 Lexus RX 330/350/400h (certain 2004 – early 2007 model year) vehicles covered by this Safety Recall.

Model Name	Model Year	Production Period	Number of Vehicles
Highlander	Certain 2004 – 2006	Mid-August 2003 to Late July 2006	Approximately 397,000 units
RX 330/350/400h	Certain 2004 – early 2007	Mid-February 2003 Late August 2006	Approximately 372,000 units

Q4: Are there any warnings for this condition?

A4: If the driver's side Floor Carpet Cover is leaning, the driver may notice it is contacting his/her foot.

Q5: How long will it take to conduct the remedy?

A5: The replacement of the Floor Carpet Cover and retention clips will take approximately 15 minutes. However, it may be necessary for the owner to make the vehicle available for a longer period of time depending upon the dealer's work schedule.

Q6: How is the shape of the new Floor Carpet Cover different from the original one?

A6: The new Floor Carpet Cover has an additional tab which extends beyond the travel of the accelerator pedal arm, so as not to interrupt the movement of accelerator pedal arm even if the cover is leaning.

Q7: What if an owner has additional questions or concerns?

A7: Owners with questions or concerns are asked to please contact the Toyota Customer Experience Center at 1-888-270-9371 Monday through Friday, 5:00 am to 6:00 pm, or Saturday 7:00 am through 4:00 pm Pacific Standard Time. They may also consult the information posted at <http://www.toyota.com/floormats>.

Q8: What if an owner has previously paid for repair to address the condition described above?

A8: Reimbursement consideration instructions will be provided in the Remedy owner letter.

**2004 – 2006 Model Year Highlander/Highlander HV
Floor Carpet Cover and Retention Clips
Safety Recall Notice (Replacement Parts Now Available)**

[VIN]

Dear Toyota Customer:

This notice is being sent to you in accordance with the requirements of the National Traffic and Motor Vehicle Safety Act. Toyota has decided that a defect, which relates to motor vehicle safety, exists in certain 2004 – 2006 Model Year Highlander/Highlander HV vehicles.

What is the condition?

As previously communicated to you, in certain 2004 through 2006 model year Highlander/Highlander HV vehicles, if the forward retention clip used to secure the driver's side Floor Carpet Cover, which is located in front of the center console, is not installed properly, the cover may lean toward the accelerator pedal and interfere with the accelerator pedal arm. If this occurs, the accelerator pedal may temporarily become stuck in a partially depressed position rather than returning to the idle position. An accelerator pedal temporarily stuck in a partially depressed position may increase the risk of a crash.

What is Toyota going to do?

The replacement parts for your vehicle are now available. Toyota will replace the Floor Carpet Cover with one of a different shape as well as both forward and rear retention clips.

What should you do?

- Please contact any Toyota dealer and make an appointment as soon as possible to have the Floor Carpet Cover and both forward and rear retention clips of your vehicle replaced at **no charge** to you.
- The replacement of the cover and clips will take approximately 20 minutes. However, depending upon the dealer's work schedule, it may be necessary to make your vehicle available for a longer period of time.

You do not need an owner letter to have this recall completed; however, to assist the dealer in confirming vehicle eligibility, we request that you present this notice at the time of your service appointment.

If you would like to update your vehicle ownership or contact information, you may do so by registering at www.toyota.com/ownersupdate. You will need your full 17-digit Vehicle Identification Number (VIN) to input the new information.

What if you have other questions?

Your local Toyota dealer will be more than happy to answer any of your questions. If you require further assistance, you may contact Toyota Customer Experience Center at 1-888-270-9371, Monday through Friday, 5:00 am to 6:00 pm, Saturday 7:00 am through 4:00 pm Pacific Time.

If you believe that the dealer or Toyota has failed or is unable to remedy the defect within a reasonable time, you may submit a complaint to the Administrator, National Highway Traffic Safety Administration, 1200 New Jersey Avenue S.E., Washington, D.C. 20590, or call the toll free Vehicle Safety Hot Line at 1-888-327-4236 (TTY: 1-800-424-9153), or go to <http://www.safercar.gov>.

What if you have previously paid for repairs to your vehicle for this specific condition?

If you have previously paid for repair to your vehicle for this specific condition prior to receiving this letter, please mail a copy of your repair order, proof-of-payment and proof-of-ownership to the following address for reimbursement consideration:

Toyota Motor Sales, U.S.A., Inc
Toyota Customer Experience, WC 10
19001 South Western Avenue
Torrance, CA 90509

Include your name, address, and telephone number(s) in your request. Please allow us 6-8 weeks to process your request.

If you are a vehicle lessor, Federal law requires that any vehicle lessor receiving this recall notice must forward a copy of this notice to the lessee within ten days.

We have sent this notice in the interest of your continued satisfaction with our products, and we sincerely regret any inconvenience this condition may have caused you.

Thank you for driving a Toyota.

Sincerely,

TOYOTA MOTOR SALES, U.S.A., INC.

SAMPLE

TECHNICAL INSTRUCTIONS

FOR

SAFETY RECALL B0A

FLOOR CARPET COVER

2004 – CERTAIN EARLY 2006 MODEL YEAR HIGHLANDER / HV

I. OPERATION FLOW CHART

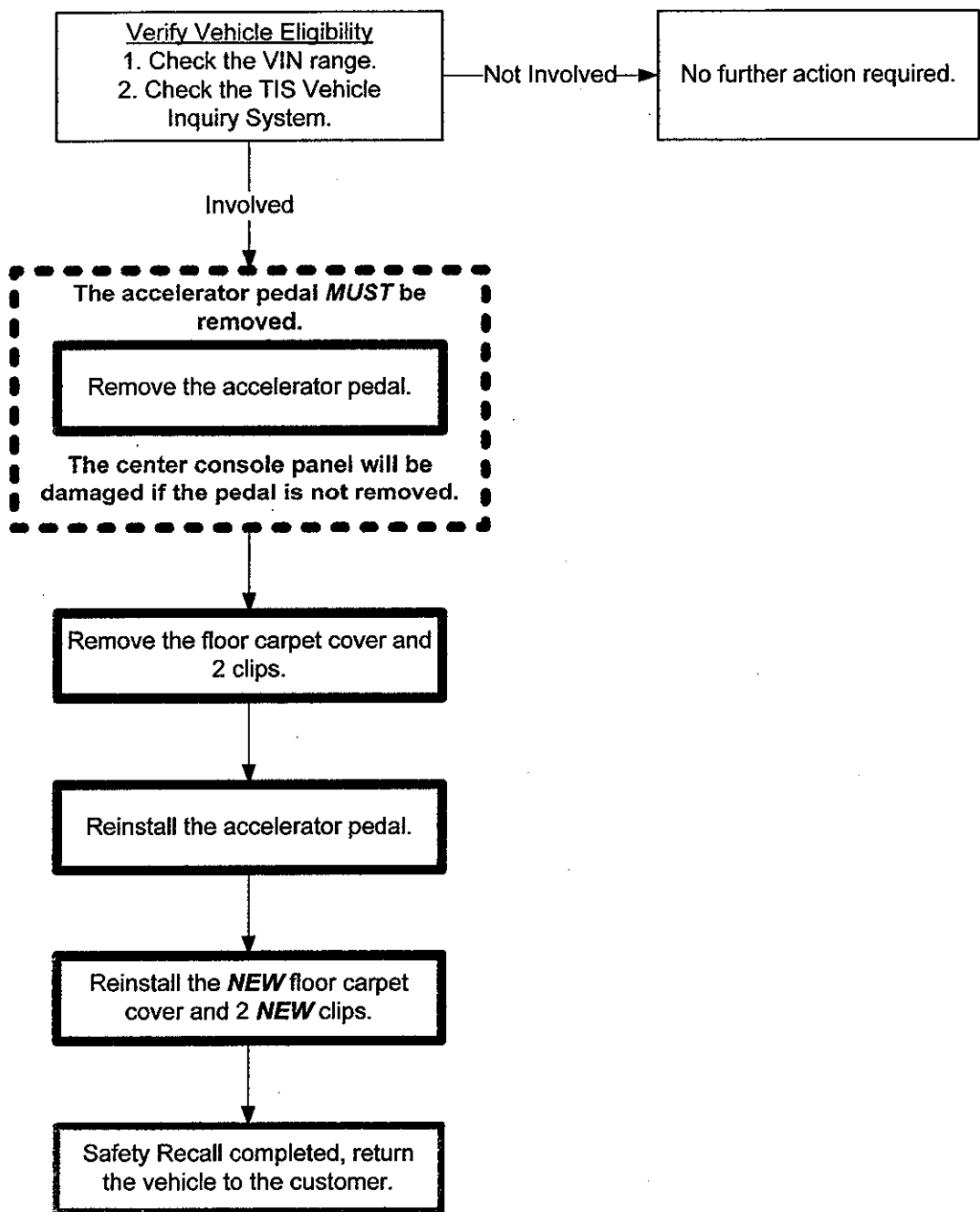

II. IDENTIFICATION OF AFFECTED VEHICLES

A. AFFECTED VIN RANGE

Model	WMI	Year	VIN Range	
			VDS	Range
HIGHLANDER	JTE	2004	DD21A	0073058 - 0105659
			DP21A	0001005 - 0043214
			ED21A	0025894 - 0031832
			EP21A	0001045 - 0067233
			GD21A	0073656 - 0105684
			GP21A	0001006 - 0043210
			HD21A	0025363 - 0033057
		2005	DD21A	0105687 - 0132243
			DP21A	0043215 - 0091384
			ED21A	0033309 - 0039278
			EP21A	0067234 - 0136405
			GD21A	0105182 - 0132242
			GP21A	0042673 - 0091386
			HD21A	0033060 - 0040125
		2006	HP21A	0118918 - 0118918
			DD21A	0132256 - 0155324
			DP21A	0091388 - 0126213
			ED21A	0040139 - 0044652
			EP21A	0136406 - 0186757
			GD21A	0132244 - 0155327
			GP21A	0090882 - 0126215
HIGHLANDER HV	JTE	2005	EW21A	0001002 - 0001004
		2006	DW21A	0001003 - 0016407
			EW21A	0001009 - 0033818
			GW21A	0001541 - 0013007
			HW21A	0001275 - 0020710

NOTE:

- Check the TIS Vehicle Inquiry System to confirm the VIN is involved in this Safety Recall, and that the campaign has not already been completed prior to dealer shipment or by another dealer.
- TMS warranty will not reimburse dealers for repairs conducted on vehicles that are not affected or were completed by another dealer.

III. PREPARATION

A. PARTS

Part Number	Part Description	Quantity
04001-1340E (Ivory)	Cover Kit, Floor Carpet, CTR LH*	1
04001-11348 (Gray)	Cover Kit, Floor Carpet, CTR LH*	1

*The kit above includes the following parts:

58534-xxxxx-xx	Floor Carpet Cover	1
90467-06020-C0	Retention Clip	2

NOTE:

The following website can be used to confirm the appropriate part kit to order based on the VIN.
<http://toyota-b0a.imagesprm.info/>

B. TOOLS & EQUIPMENT

- Standard hand tools
- Torque wrench

IV. BACKGROUND

In certain 2004 through 2006 model year Highlander and Highlander HV vehicles, if the forward retention clip used to secure the driver's side Floor Carpet Cover, which is located in front of the center console, is not installed properly, the cover may lean toward the accelerator pedal and interfere with the accelerator pedal arm. If this occurs, the accelerator pedal may temporarily become stuck in a partially depressed position rather than return to the idle position. An accelerator pedal temporarily stuck in a partially depressed position may increase the risk of a crash.

V. WORK PROCEDURE

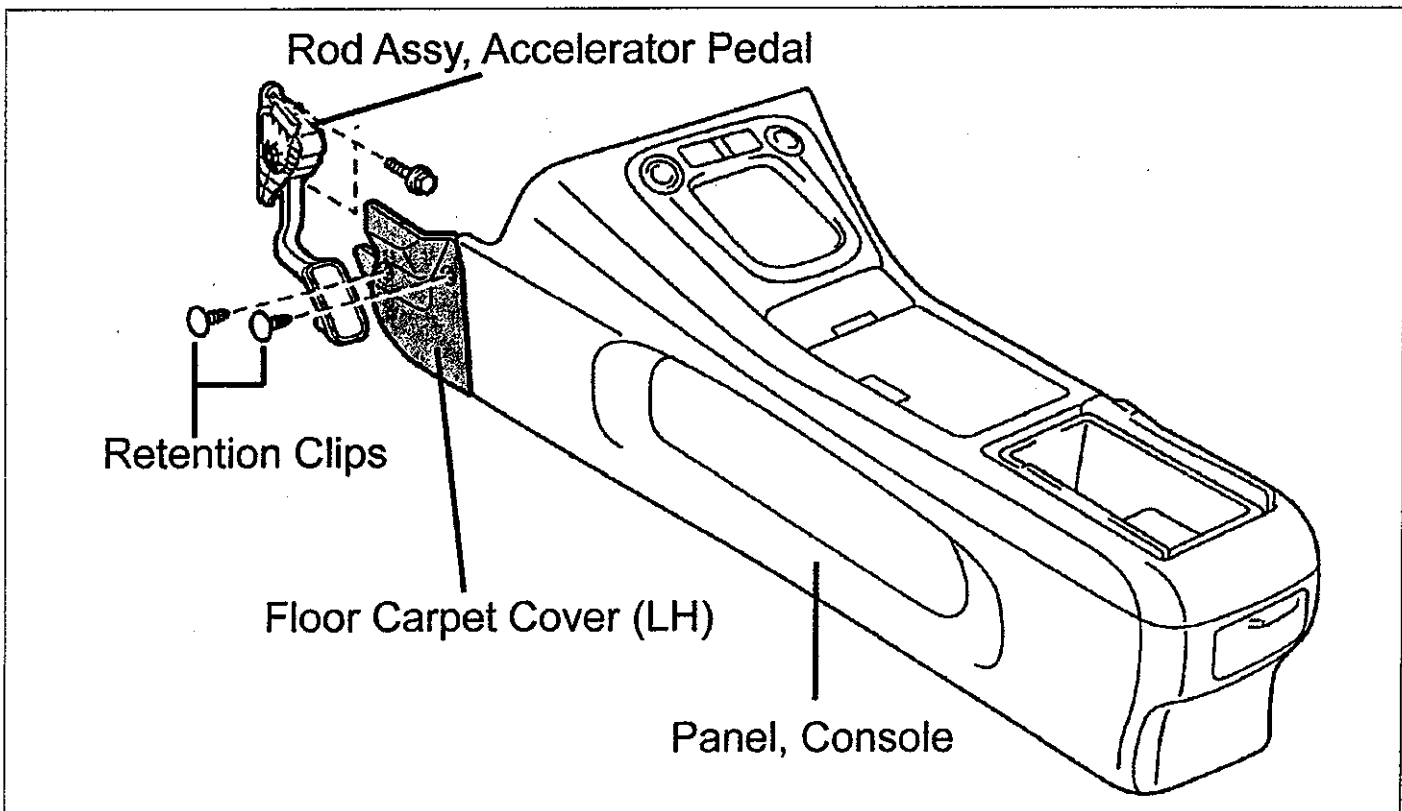

A. REPLACE THE CARPET COVER AND CLIPS

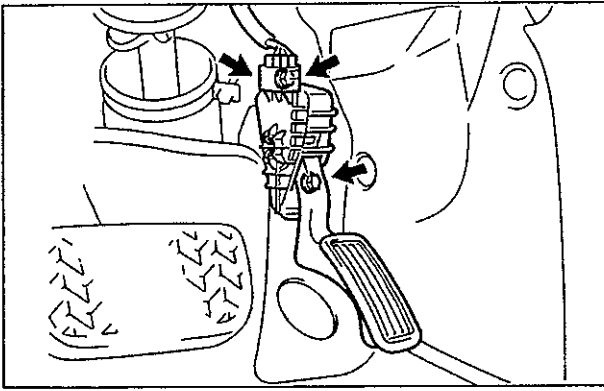

1. REMOVE THE ACCELERATOR PEDAL ASSEMBLY

- a) Record the radio station presets.
- b) Disconnect the negative battery cable and wait 90 seconds.
- c) Disconnect the accelerator pedal connector.
- d) Remove the 2 nuts and accelerator pedal assembly.

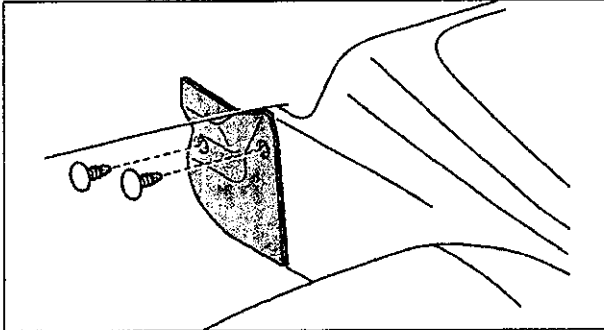

2. REMOVE THE CARPET COVER CLIPS

- a) Remove the two retention clips.

3. REMOVE THE CARPET COVER



The accelerator pedal **MUST** be removed. The center console panel will be damaged if the pedal is not removed.

- a) Tilt the front of the carpet cover toward the brake pedal.
- b) Move the carpet cover toward the front of the vehicle to remove it.

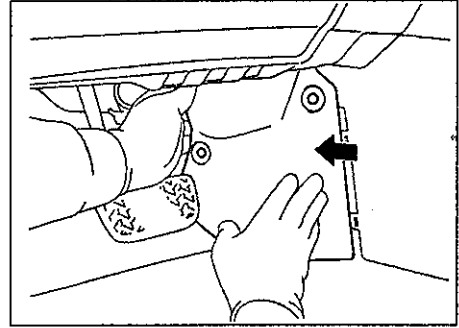
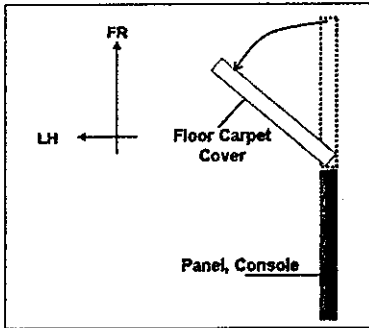
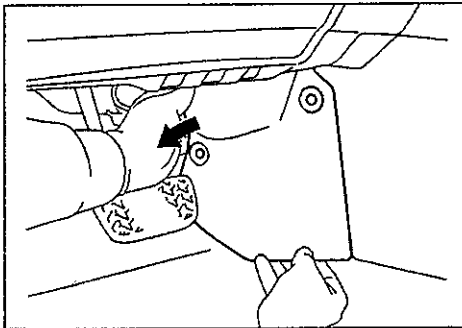

4. REINSTALL THE ACCELERATOR PEDAL ASSEMBLY

Torque: 4.9 Nm (50 kgf cm, 43 in. lbf)

5. REINSTALL THE NEW CARPET COVER AND TWO NEW CLIPS

6. RECONNECT THE NEGATIVE BATTERY CABLE

7. CONFIRM THE PEDAL OPERATES PROPERLY AND NOTHING INTERFERES WITH THE PEDAL

◀ VERIFY REPAIR QUALITY ▶

- Confirm the pedal is reinstalled correctly
- Confirm the carpet cover is reinstalled correctly
- Confirm the correct retention clips are used and secure
- Confirm nothing interferes with accelerator pedal operation
- If you have any questions regarding this recall, please contact your regional representative

VI. APPENDIX

As required by Federal Regulations, please make sure all recalled parts (original parts) removed from the vehicle are disposed of in a manner in which they will not be reused, ***unless requested for parts recovery return.***