

Safety Defect and Noncompliance Report Guide for Vehicles
PART 573 Defect and Noncompliance Responsibility and Reports¹

On _____, 2010, Tiffin Motorhomes, Inc. [MFR] decided that a defect which relates to motor vehicle safety exists in the motor vehicles listed below, and is furnishing notification to the National Highway Traffic Safety Administration in accordance with 49 CFR Part 573 Defect and Noncompliance Responsibility and Reports.

Date this report was prepared: 8-24-2011

Furnish the manufacturer's identification code for this recall (if applicable): _____

1. Identify the full corporate name of the fabricating manufacturer of the vehicle being recalled. If the recalled vehicle is imported, provide the name and mailing address of the designated agent as prescribed by 49 U.S.C. §30164.

Tiffin Motorhomes, Inc.
105 2nd St. NW
Red Bay, AL 35582

Identify the corporate official, by name and title, whom the agency should contact with respect to this recall.

Bob Tiffin, President

Telephone Number: 256-356-8661 Fax No.: 256-356-6863

Name and Title of Person who prepared this report.

Elizabeth Jones
Office Secretary

Signed:

¹ Each manufacturer must furnish a report, to the Associate Administrator for Enforcement, for each defect or noncompliance condition which relates to motor vehicle safety.

I. Identify the Vehicle Models Involved in the Recall

2. Identify the Vehicles Involved in the Recall, for each make and model or applicable vehicle line (provide illustrations or photographs as necessary to describe the vehicle), provide:

Make(s): _____ Model Years Involved: _____ Model(s): _____

Production Dates: Beginning: _____ Ending: _____

VIN Range: Beginning: _____ Ending: _____

Vehicle Type: _____ Bodystyle: _____

Descriptive information which characterizes/distinguishes the recalled vehicles from those model vehicles not included in the recall:

Make(s): _____ Model Years Involved: _____ Model(s): _____

Production Dates: Beginning: _____ Ending: _____

VIN Range: Beginning: _____ Ending: _____

Vehicle Type: _____ Bodystyle: _____

Descriptive information which characterizes/distinguishes the recalled vehicles from those model vehicles not included in the recall:

Make(s): _____ Model Years Involved: _____ Model(s): _____

Production Dates: Beginning: _____ Ending: _____

VIN Range: Beginning: _____ Ending: _____

Vehicle Type: _____ Bodystyle: _____

Descriptive information which characterizes/distinguishes the recalled vehicles from those model vehicles not included in the recall:

Identify the approximate percentage of the production of all the recalled models manufactured by your company between the inclusive dates of manufacture provided above, that the recalled model population represents. For example, if the recall involved Vehicles equipped with certain items of equipment from January 1, 1996 through April 1, 1997, then what was the percentage of the recalled Vehicles of all Vehicles manufactured during that time period.

II. Identify the Recall Population

3. Furnish the total number of vehicles recalled potentially containing the defect or noncompliance.

<u>Model</u>	<u>Year</u>	<u>Number of Vehicles Potentially Involved</u>
Phacton	2007	27
Phacton	2008	853
Phacton	2009	450
Phacton	2010	317
Phacton	2011	1
Bus	2008	147
Bus	2009	38
Bus	2010	8
Allegro	2010	1
Total Number Potentially Affected by the Recall:		<u>1960</u>

4. Furnish the approximate percentage of the total number of vehicles estimated to actually contain the defect or noncompliance: unknown

Identify and describe how the recall population was determined--in particular how the recalled models were selected and the basis for the beginning and final dates of manufacture of the recalled vehicles:

^(Daimler)
 Freightliner has notified Tiffin Motorhomes that there is a problem in certain Adjustable Pedal, Pneumatic & Hydraulic Braking Systems supplied to Freightliner from Kongsberg. Freightliner supplied Tiffin's with these chassis.

* Reference Kongsberg's NHTSA # 09E-064
 + Freightliner's NHTSA # 09V-461.

III. Describe the Defect or Noncompliance

5. Describe the defect or noncompliance. The description should address the nature and physical location of the defect or noncompliance. Illustrations should be provided as appropriate.

The issue is that the drive pin which secures the brake pedal arm to the remainder of the assembly may become disengaged.

Describe the cause(s) of the defect or noncompliance condition.

stated above

Describe the consequence(s) of the defect or noncompliance condition.

Could result in a loss of vehicle braking function and/or cause the brake pedal to move out of position & interfere with the throttle pedal function.

Identify any warning which can (a) precede or (b) occur.

Could happen without warning.

If the defect or noncompliance is in a component or assembly purchased from a supplier, identify the supplier by corporate name and address.

Chassis supplier: Freightliner (Daimler)

P.O. Box 4090

Portland OR 97208-4090

Brake supplier to Freightliner:

Kongsberg Power Product System

300 S. Cochran / P.O. Box 588

Willis TX 77378-0588

Identify the name and title of the chief executive officer or knowledgeable representative of the supplier:

IV. Provide the Chronology in Determining the Defect/Noncompliance

If the recall is for a defect, complete item 6, otherwise item 7.

6. With respect to a defect, furnish a chronological summary (including dates) of all the principle events that were the basis for the determination of the defect. The summary should include, but not be limited to, the number of reports, accidents, injuries, fatalities, and warranty claims.

7. With respect to a noncompliance, identify and provide the test results or other data (in chronological order and including dates) on which the noncompliance was determined.

N/A

V. Identify the Remedy

8. A description of the manufacturer's program for remedying the defect or noncompliance. This program shall include a plan for reimbursing an owner or purchaser who incurred costs to obtain a remedy for the problem addressed by the recall within a reasonable time in advance of the manufacturer's notification of owners, purchasers and dealers, in accordance with §573.13 of this part. A manufacturer's plan may incorporate by reference a general reimbursement plan it previously submitted to NHTSA, together with information specific to the individual recall. Information required by §573.13 that is not in a general reimbursement plan shall be submitted in the manufacturer's report to NHTSA under this section. If a manufacturer submits one or more general reimbursement plans, the manufacturer shall update each plan every two years, in accordance with §573.13. The manufacturer's remedy program and reimbursement plans will be available for inspection by the public at NHTSA headquarters.

KPPS & Freightliner HAVE provided
Kits to remedy situation.

9. Furnish a description of the manufacturer's remedy for the defect or noncompliance. Clearly describe the differences between the recall condition and the remedy.

SEE ATTACHED paper work from
Freightliner (Diamler)

Clearly describe the distinguishing characteristics of the remedy component/assembly versus the recalled component/assembly.

Identify and describe how and when the recall condition was corrected in production. If the production remedy was identical to the recall remedy in the field, so state. If the product was discontinued, so state.

VI. Identify the Recall Schedule

10. Furnish a schedule or agenda (with specific dates) for notification to other manufacturers, dealers/retailers, and purchasers. Please, identify any foreseeable problems with implementing the recall.

Tiffin supplied Freightliner (Diamler) with names + address of all customers they did NOT already HAVE in their data base. Freightliner has already contacted owners of units involved.

VII. Furnish Recall Communications

11. Furnish a final copy of all notices, bulletins, and other communications that relate directly to the defect or noncompliance and which are sent to more than one manufacturer, distributor, or purchaser. This includes all communications (including both original and follow-up) concerning this recall from the time your company determines the defect or noncompliance condition on, not just the initial notification. A DRAFT copy of the notification documents should be submitted to this office by Fax (202-366-7882) or by E-Mail to RMD.ODI@dot.gov for review prior to mailing.

Note that these documents are to be submitted separately from those provided in accordance with Part 579.5 requirements.

Subject: KPPS Adjustable Brake Pedals

Models Affected: Specific Freightliner Custom Chassis B2 school bus chassis (Thomas Built Buses Saf-T-Liner C2 school buses) manufactured October 6, 2004, through November 12, 2009, and XC motorhome chassis manufactured March 6, 2007, through December 11, 2009, with certain Kongsberg Power Products Systems (KPPS) adjustable brake pedals. (Please note, there are also three XB shuttle bus chassis included in this recall.)

General Information

Daimler Trucks North America LLC, on behalf of its wholly owned subsidiary, Freightliner Custom Chassis Corporation, has decided that a defect that relates to motor vehicle safety exists on the vehicles mentioned above.

There are approximately 9,000 vehicles involved in this campaign.

The adjustable brake pedal may loosen. The drive pin which secures the brake pedal arm to the balance of the assembly may become disengaged, this may cause a reduction in vehicle braking and/or cause the brake pedal to move out of position and interfere with throttle pedal function. A reduction in braking or interference with the throttle pedal could result in a vehicle crash.

A clamp assembly will be installed on the adjustable brake pedal arm, preventing it from loosening. It is expected that all vehicles need the clamp assembly installed. An inspection is included to catch any vehicles that were repaired at the factory before delivery.

REVISIONS: Motorhome chassis have been added as FL569B and a new kit for this group has been added. The Work Instructions have been updated to show that the C-clamp assembly comes with the top bolt pre-torqued. The procedure is the same for all vehicles.

Additional Repairs

Dealers must complete all outstanding recall and field service campaigns prior to the sale or delivery of a vehicle. A Dealer will be liable for any progressive damage that results from its failure to complete campaigns before sale or delivery of a vehicle.

Owners may be liable for any progressive damage that results from its failure to complete campaigns within a reasonable time after receiving notification.

Work Instructions

Please refer to the attached work instructions. Prior to performing the campaign, check the vehicle for a completion sticker (Form WAR260).

Replacement Parts

Replacement kits are now available and can be obtained by ordering the kit number(s) listed below from your facing Parts Distribution Center.

If our records show your dealership has ordered any vehicles involved in campaign number FL569A, a list of the customers and vehicle identification numbers will be available on AccessFreightliner.com. Please refer to this list when ordering parts for this recall.

NOTE: Completion stickers are not included in the kits. Please use blank completion stickers and write in the recall number, FL569.

Recall Campaign

January 2010
 FL569AB
 NHTSA #09V-461
 REVISED NOTICE

Table 1 - Replacement Parts for FL569A

Campaign Number	Kit Number	Part Description	Part Number	Qty.	Suggested Wholesale*
FL569A	25-FL569-000	C-Clamp Assembly Kit - School Buses	KPPS Kit #318282	1 kit	\$.96 U.S. \$1.01 CAN
FL569B	25-FL569-001	C-Clamp Assembly Kit - Motorhomes	KPPS Kit #318297	1 kit	\$.96 U.S. \$1.01 CAN

* Please charge all Direct Warranty Customers the above-listed price for the kit, as they are authorized to perform their own Recalls.

Table 1

Removed Parts

Please follow Warranty Failed Parts Tracking shipping instructions for the disposition of all removed parts.

Labor Allowance

NOTE: It is expected that all vehicles need the clamp assembly installed. An inspection is included to catch any vehicles that were repaired at the factory before delivery.

Table 2 - Labor Allowance

Campaign Number	Procedure	Time Allowed (hours)	SRT Code	Damage Code
FL569AB	Inspect and install a C-clamp on the adjustable brake pedal	0.2	996-0798A	000-Modifiedx
	Inspect for and find C-clamp or roll pin on the adjustable brake pedal,	0.2	996-0798B	000-Inspected

Table 2

IMPORTANT: When the recall has been completed, locate the base completion label in the appropriate location on the vehicle, and attach the red completion sticker provided in the recall kit (Form WAR260). If the vehicle does not have a base completion label, clean a spot on the appropriate location of the vehicle and first attach the base completion label (Form WAR259). If a recall kit is not required or there is no completion sticker in the kit, write the recall number on a blank sticker and attach it to the base completion label.

Claims for Credit

You will be reimbursed for your parts, labor, and handling by submitting your claim through the Warranty system within 30 days of completing this campaign. Please reference the following information in QuickClaim®:

- Claim type is **Recall**.
- In the FTL Authorization field, enter the campaign number and appropriate condition code (**FL569A**).
- In the Primary Failed Part Number field, enter **25-FL569-000**.
- In the Parts field, enter the appropriate kit number(s) as shown in the Replacement Parts Table.
- In the Labor field, first enter the appropriate SRT from the Labor Allowance Table. For administrative time, enter SRT 939-0010A for 0.4 hours for RVs or 0.3 hours for all other vehicles.
- **Reimbursement for Prior Repairs.** When a customer asks about reimbursement, please do the following.
 - Accept the documentation of the previous repair.

- Make a brief check of the customer's paperwork to see if the repair may be eligible for reimbursement. (See the "Copy of Owner Letter" section of this bulletin for reimbursement guidelines for this recall.)
- Contact the Warranty Campaigns Department for a decision and authorization number.
- Include the approved amount on your claim in sublet/outside purchases.
- In the claim story, first note the authorization number and that the claim includes a reimbursement request.
- Retain the documentation and provide it to Warranty Campaigns or Claims Processing if requested.
- When your claim is paid, reimburse the customer the appropriate amount.

IMPORTANT: ServicePro® must be viewed prior to performing the recall to ensure the vehicle is involved and the campaign has not been previously completed. Also, check for a completion sticker prior to beginning work.

Contact the Warranty Campaigns Department at (800) 547-0712, from 7:00 a.m. to 4:00 p.m. Pacific Time, Monday through Friday, Web inquiry at AccessFreightliner.com / Support / Submit an Inquiry, or the Customer Assistance Center at (800) 385-4357, after normal business hours, if you have any questions or need additional information.

To return excess kit inventory related to this campaign, U.S. dealers must submit a Parts Authorization Return (PAR) to the Memphis PDC. Canadian dealers must submit a PAR to their facing PDC. All kits must be in resalable condition. PAR requests must include the original purchase invoice number.

The letter notifying vehicle owners is included for your reference.

Please note that the National Traffic and Motor Vehicle Safety Act, as amended (Title 49, United States Code, Chapter 301), requires the owner's vehicle(s) be corrected within a reasonable time after parts are available to you. The Act states that failure to repair a vehicle within 60 days after tender for repair shall be prima facie evidence of an unreasonable time. However, circumstances of a particular situation may reduce the 60 day period. Failure to repair a vehicle within a reasonable time can result in either the obligation to (a) replace the vehicle with an identical or reasonably equivalent vehicle, without charge, or (b) refund the purchase price in full, less a reasonable allowance for depreciation. The Act further prohibits dealers from selling a vehicle unless all outstanding recalls are performed. Any lessor is required to send a copy of the recall notification to the lessee within 10 days. Any subsequent stage manufacturer is required to forward this notice to its distributors and retail outlets within five working days.

Recall Campaign

January 2010
FL569AB
NHTSA #09V-461
REVISED NOTICE

Copy of Letter to Owner Subject: KPPS Adjustable Brake Pedals

This notice is sent to you in accordance with the requirements of the National Traffic and Motor Vehicle Safety Act. This notice is also sent in accordance with the Canadian Motor Vehicles Safety Act.

Daimler Trucks North America LLC, on behalf of its wholly owned subsidiary, Freightliner Custom Chassis Corporation, has decided that a defect which relates to motor vehicle safety exists on specific Freightliner Custom Chassis B2 school bus chassis (Thomas Built Buses Saf-T-Liner C2 school buses) manufactured October 6, 2004, through November 12, 2009, and XC motorhome chassis manufactured March 6, 2007, through December 11, 2009, with certain Kongsberg Power Products Systems (KPPS) adjustable brake pedals. (Please note, there are also three XB shuttle bus chassis involved in this recall.)

The adjustable brake pedal may loosen. The drive pin which secures the brake pedal arm to the balance of the assembly may become disengaged, this may cause a reduction in vehicle braking and/or cause the brake pedal to move out of position and interfere with throttle pedal function. A reduction in braking or interference with the throttle pedal could result in a vehicle crash.

A clamp assembly will be installed on the adjustable brake pedal arm, preventing it from loosening.

Parts are now available for authorized dealers to order. Contact your authorized dealer to arrange to have the recall performed and to ensure that parts are available at the dealership. To locate a dealer, search online at www.FreightlinerTrucks.com or contact the Warranty Campaigns Department for assistance.

When you contact your dealer, refer to campaign number **FL569A**. Once kit(s) are received at the dealership, the Recall will take approximately half an hour and will be performed at no charge to you.

IMPORTANT: When the Recall has been completed, please ensure that a label has been affixed to your vehicle referencing **FL569A**.

If you do not own the vehicle that corresponds to the identification number(s) which appears on the Recall Notification, please return the notification to the Warranty Campaigns Department with any information you can furnish that will assist us in locating the present owner. If you have leased this vehicle, Federal law requires that you forward this notice to the lessee within 10 days. If you are a subsequent stage manufacturer, Federal law requires that you forward this notice to your distributors and retail outlets within five working days. If you have paid to have this recall condition corrected prior to this notice, you may be eligible to receive reimbursement. Please see the reverse side of this notice for details.

If you are not able to have the defect remedied without charge and within a reasonable time, which is not longer than 60 days after you tender the vehicle for repair, please contact the Warranty Campaigns Department at (800) 547-0712, 7:00 a.m. to 4:00 p.m. Pacific Time, Monday through Friday, e-mail address DTNA.Warranty.Campaigns@Daimler.com, or the Customer Assistance Center at (800) FTL-HELP or (800) STL-HELP, after normal business hours. You may also wish to submit a complaint to the Administrator, National Highway Traffic Safety Administration, 1200 New Jersey Avenue, SE., Washington, DC 20590; or call the Vehicle Safety Hotline at (888) 327-4236 (TTY: 800-424-9153); or to <http://www.safercar.gov>. If your vehicle is involved in the Canadian portion, you may wish to notify Transport Canada, ASFAD, Place de Ville Tower C, 330 Sparks Street, Ottawa, ON K1A 0N5, or phone (800) 333-0510.

We regret any inconvenience this action may cause but feel certain you understand our interest in motor vehicle safety.

WARRANTY CAMPAIGNS DEPARTMENT

Enclosure

Reimbursement to Customers for Repairs Performed Prior to Recall

If you have already paid to have this recall condition corrected you may be eligible to receive reimbursement.

Requests for reimbursement may include parts and labor. Reimbursement may be limited to the amount the repair would have cost if completed by an authorized Daimler Trucks North America LLC dealer. The following documentation must be presented to your dealer for consideration for reimbursement.

Please provide original or clear copies of all receipts, invoices, and repair orders that show:

- The name and address of the person who paid for the repair.
- The Vehicle Identification Number (VIN) of the vehicle that was repaired.
- What problem occurred, what repair was done, when the repair was done.
- Who repaired the vehicle.
- The total cost of the repair expense that is being claimed.
- Proof of payment for the repair (such as the front and back of a cancelled check or a credit card receipt).

Reimbursement will be made by check from your Daimler Trucks North America LLC dealer.

Please speak with your Daimler Trucks North America LLC authorized dealer concerning this matter.

Recall Campaign

Daimler Trucks
North America LLC

January 2010
FL569AB
NHTSA #09V-461
REVISED NOTICE

Work Instructions

Subject: KPPS Adjustable Brake Pedals

Models Affected: Specific Freightliner Custom Chassis B2 school bus chassis (Thomas Built Buses Saf-T-Liner C2 school buses) manufactured October 6, 2004, through November 12, 2009, and XC motorhome chassis manufactured March 6, 2007, through December 11, 2009, with certain Kongsberg Power Products Systems (KPPS) adjustable brake pedals. (Please note, there are also three XB shuttle bus chassis included in this recall.)

REVISIONS: Motorhome chassis have been added as FL569B and a new kit for this group has been added. The Work Instructions have been updated to show that the C-clamp assembly comes with the top bolt pre-torqued. The procedure is the same for all vehicles.

NOTE: It is expected that all vehicles need the clamp assembly installed. An inspection is included to catch any vehicles that were repaired at the factory before delivery.

Inspection

1. Check the base label (Form WAR259) for a completion sticker for campaign FL569 (Form WAR260) indicating this work has been done. The base label is usually located above the driver's window on school buses or on the front wall under the dash on motorhomes. If a completion sticker for this campaign is present, no further work is needed. If a completion sticker is not present, proceed with the next step.
2. Park the vehicle on a level surface, shut down the engine, apply the parking brake, and chock the tires.
3. Check to see if a C-clamp or roll pin is installed on the adjustable brake pedal. See **Fig. 1**.
4. If either a C-clamp or a roll pin is found, no further work is needed. Clean a spot on the base label (Form WAR259), write the recall number, FL569, on a blank completion sticker (Form WAR260), and attach it to the base label. Remove the chocks from the tires.

If a C-clamp or a roll pin is not found, go to "C-clamp Installation" below.

C-clamp Installation

NOTE: The bolt threads come equipped with an application of Loctite®. The top bolt of the C-clamp assembly comes pre-torqued.

1. With the C-clamp in your hand, install the C-clamp assembly in the guide hole at the top of the brake arm casting. Make certain the C-clamp is against the casting. The bolt with the lockwasher should be installed at the top, as shown in **Fig. 1**, Items 4 and 5. Then tighten the bottom bolt 40±5 lbf-in (452±5 N-cm).
2. Clean a spot on the base label (Form WAR259), write the recall number, FL569, on a blank completion sticker (Form WAR260), and attach it to the base label.
3. Remove the chocks from the tires.

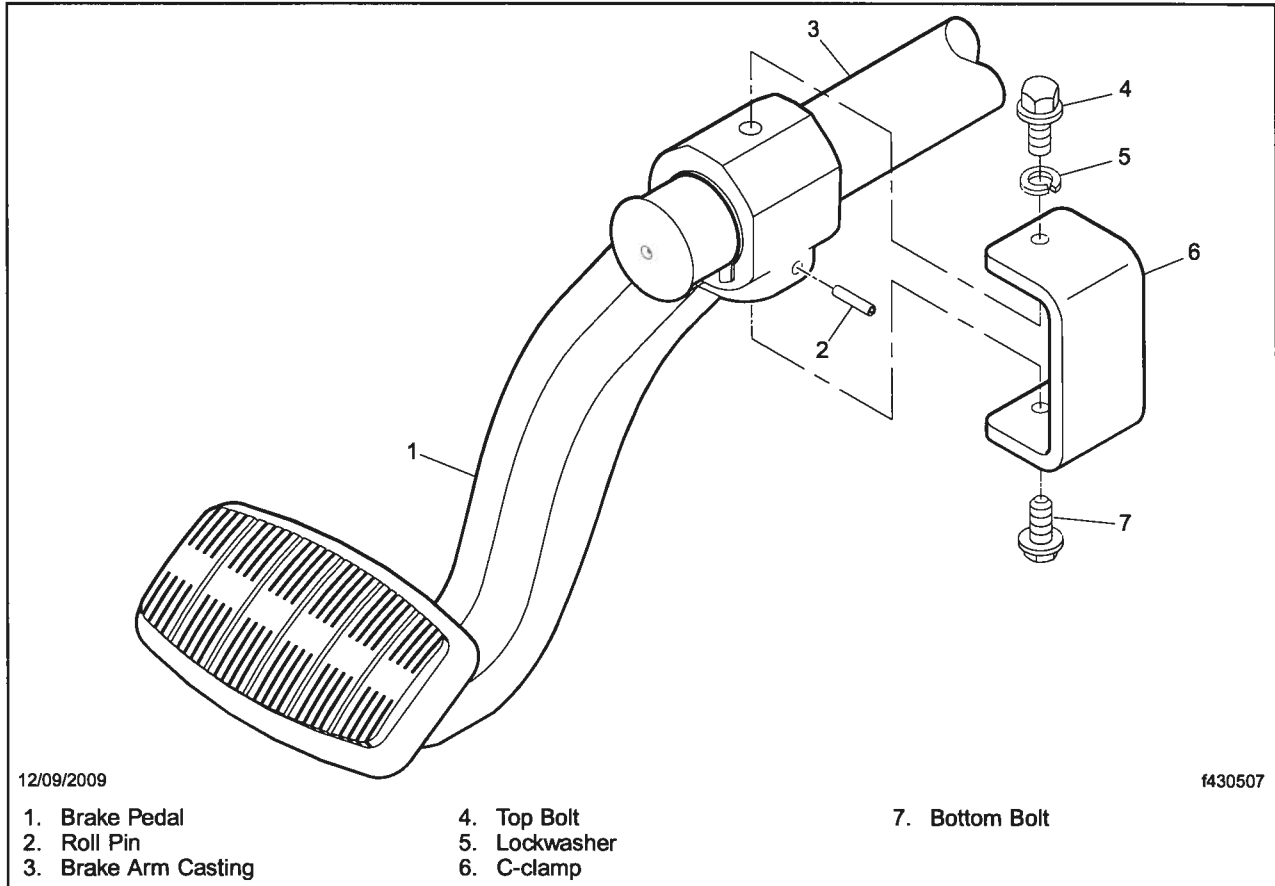

Fig. 1, Adjustable Brake Pedal Assembly

**Daimler Trucks
North America LLC**

Daimler Trucks North America LLC
P.O. Box 4090
Portland, OR 97208-4090
800.547.0712 Phone
503.745.9009 Fax

**January 2010
FL569
NHTSA #09V-461
TC #09-338**

**Recall Notification
Subject: KPPS Adjustable Brake Pedals**

Daimler Trucks North America has begun notifying its dealers and customers of a safety related defect that exists in certain chassis manufactured by Freightliner Custom Chassis Corporation and delivered to your company. A remedy without charge is now available, and owners may take their vehicle to a Daimler Trucks North America-authorized service facility to have the recall performed. The Recall Bulletin, which includes a representative copy of the owner notification and dealer work instructions, and a list of potentially affected vehicles delivered to you are attached for your information.

Your company may have an obligation to notify its dealers, distributors, and customers of this recall under Title 49 Code of Federal Regulations Part 577.13 and/or Motor Vehicle Safety Act Section 10(1).

If you have questions or need further information, please contact the Warranty Campaigns Department at (800) 547-0712, 7:00 a.m. to 4:00 p.m. Pacific Time.

WARRANTY CAMPAIGNS DEPARTMENT
Enclosure