



## Recall Action Notice

**Service Bulletin 416  
December 2010**

---

**Affected Models** .....**Sprint ST and Sprint GT**

**VIN Range**.....**466932 to 473209**

**Markets** .....**All**

**Subject**.....**Engine Oil Filler Plug/Dipstick**

### **Background Information**

We have identified that the engine oil filler plug/dipstick needs to be replaced to avoid a low oil condition after filling or topping up the engine oil. Dealers are requested to remove and replace the engine oil filler plug/dipstick.

### **Customer Contact Instructions**

Triumph subsidiaries and distributors must instigate a recall action in their country in accordance with the national recall code of practice. For vehicles in dealer stock, the recall **MUST** be actioned before delivery to the customer.

### **Identification of Affected Motorcycles**

Sprint ST and Sprint GT motorcycles listed in the VIN range above.

### **Warranty Claim Instructions**

Fault code .....01264091

Repair code .....99416

Repair time allowance .....0.08 hrs (includes admin allowance)

### **Parts Information**

Parts .....1 x T1261417 Filler Plug/Dipstick

**Parts ordering instructions** ..... **For Triumph Subsidiary and Overseas Distributor dealers using Triumph Warranty On-Line with Parts Auto Ordering Flag switched on:** Order all repair parts by submitting a New Prior through the Warranty On-Line system. Entering the above repair code in a New Prior will automatically add the parts required and labour times for this Service Bulletin.

**For Overseas Distributor dealers NOT using Triumph Warranty On-Line or for Overseas Distributor dealers using Triumph Warranty On-Line with Parts Auto Ordering Flag switched off:** Orders should be placed using the normal parts ordering procedure.

**Parts return instructions** ..... Dealer to retain parts for 90 days. All parts must be stored in a secure, non-public accessed area and correctly identified with a completed warranty label. Thereafter the parts must be rendered unusable prior to scrapping.

## Other Instructions

Once completed, please mark the service record book that the requirements of this bulletin have been complied with.

## Replacement Procedure

Replace the engine oil filler plug/dipstick following the procedure listed below:

### **Warning**

Throughout the following procedure, ensure that the motorcycle is stabilised and adequately supported to prevent the risk of injury from the motorcycle falling.

## Note:

- **Some affected motorcycles listed in the VIN range on page 1 will have been modified and repaired by Triumph prior to their release from the factory.**
- **The modified motorcycles can be identified by checking the 'Outstanding Service Bulletins' on Warranty On-Line.**
- **For this service bulletin, the new engine oil filler plug/dipstick can be identified by the hole in the head of the filler plug/dipstick.**

## Removal

1. Remove and retain the original engine oil filler plug/dipstick as described in the parts return instructions on page 2.
2. Fit the new engine oil filler plug/dipstick, identified by the hole in it. Note the position of the upper and lower markings.

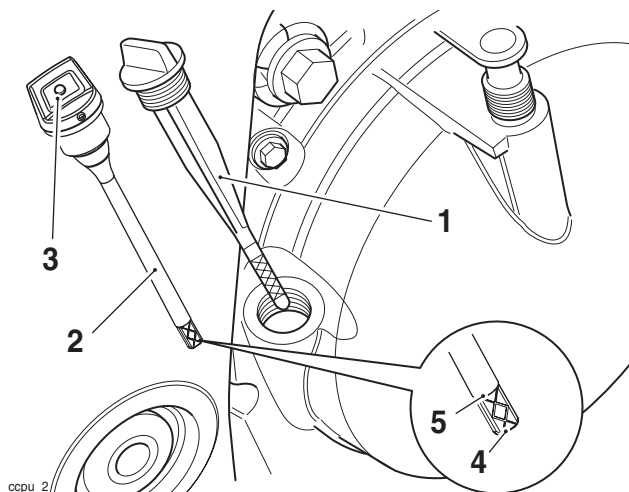

1. Old condition filler plug/dipstick
2. New condition filler plug/dipstick
3. Hole
4. Lower marking
5. Upper marking

### Note:

- **An accurate indication of the level of oil in the engine is only shown when the engine oil is at normal operating temperature, the motorcycle is upright (not on the side or centre stand) and the filler plug/dipstick has been fully screwed home.**
3. Fitting the new engine oil plug/dipstick may require the oil level to be increased. Check and, if necessary, adjust the oil level as described in the owner's handbook.

## Circulation

(Initial and date when read and return to central file holder)

Service Manager	Parts Manager	Sales Manager	Workshop Supervisor	Technician 1	Technician 2