

SERVICE PROCEDURE

**G-10520
DECEMBER 2010**

**SUBJECT: SAFETY RECALL
DRIVELINE CENTER BEARING on certain ProStar
models built 9/22/10 thru 12/3/10 with driveline
feature code 06WAK.**

DEFECT DESCRIPTION

The rubber isolator material that holds the driveline center bearing in the mounting bracket may deteriorate due to an incorrect mounting location possibly resulting in driveline separation without warning.

MODELS INVOLVED

This safety recall involves certain ProStar models built 9/22/10 thru 12/3/10 with driveline feature code 06WAK.

PARTS INFORMATION

1. Follow the instructions below to expedite the receiving of repair parts. If this expedited process on ISIS is no longer functioning, go to steps 2 and 3.
 - a. Enter the VIN into ISIS Write –Up.
 - b. Go to the Managed Repair Tab in ISIS
 - c. Select ProStar Driveline Center Bearing Ordering Process. Click on the Launch Process Button.
 - d. Fill out the online form.
 - e. Submit the form.
 - f. A managed Repair Case file will be created for parts tracking.
 - g. The parts will be shipped and the Managed Repair case file will be updated with ship date and shipping information.

Extranet Home Sites



ISIS
Vehicle Information

Open Menu Home On Command Repair Management Parts Catalog Feedback View Selection Logoff

Chassis: 9J219221
View Reset

Select Tab(s) to Print

Summary **Managed Repairs** Details Components Serial Numbers Service Contracts Warranty History iKnow Search Case History iApprove iRequest

VIN : 3HSDJSJR0BN376383

Reserve/Release	Type	Number	Description	Status	RO Number	Dealer Location	Active
<input type="button" value="Reserve"/>	MIN	10116	MAXXFORCE 11/13 2010 ENGINES				
<input type="button" value="Reserve"/>	MIN	10112	SART MODULE PARASITIC BATTERY				
<input type="button" value="Reserve"/>	RECALL	10520	ProStar Driveline Center Bearing				

Managed Repair Items on this VIN:

Name	Description	Instructions	Expiration Date	Complete Date	Case #	Select
10520 ProStar Driveline Center Bearing	Parts Ordering Process for Recall 10520					<input type="button" value="Launch Process"/>

2. All vehicles will need the center bearing repair kit.

Part Number	Part Description	Quantity
8900218R91	Kit, SR10520 ProStar Center Bearing Repair	1

Part Number **8900218R91** contains the following parts:

Part Number	Part Description	Quantity
3907176C1	Support	1
3620410C1	Block, Center Bearing Mtg Bracket	2
414087C1	Nut, Lock Flange, 1/2-20	4
414059C1	Bolt, Hex Flange Head, 1/2-20x3.25	2
414052C1	Bolt, Hex Flange Head, 1/2-20x1.50	2
5003323	Center Bearing Kit	1

3. Inspect the vehicle's lineset ticket and order a "U" joint strap kit accordingly.

Feature Code	Part Number	Part Description	Qty
06DAW	2500675C91	KIT, SPL250 "U" Joint Straps	1
06DAV	2500674C91	KIT, SPL170 "U" Joint Straps	
06DAG	1658835C91	KIT, 1810 "U" Joint Straps	

SERVICE PROCEDURE

WARNING! PARK VEHICLE ON HARD FLAT SURFACE, TURN THE ENGINE OFF, SET THE PARKING BRAKE AND BLOCK THE WHEELS TO PREVENT THE VEHICLE FROM MOVING IN BOTH DIRECTIONS. FAILURE TO DO SO MAY RESULT IN PROPERTY DAMAGE, PERSONAL INJURY AND/OR DEATH.

WARNING! IF THE VEHICLE MUST BE RAISED, DO NOT WORK UNDER THE VEHICLE SUPPORTED ONLY BY JACKS. JACKS CAN SLIP OR FALL OVER, POTENTIALLY RESULTING IN PROPERTY DAMAGE, PERSONAL INJURY AND/OR DEATH.

WARNING! ALWAYS WEAR SAFE EYE PROTECTION WHEN PERFORMING VEHICLE MAINTENANCE. FAILURE TO DO SO MAY RESULT IN SERIOUS EYE INJURY.

1. Determine if the repair is needed by inspecting the center bearing installation.
 - a. The repair **is not required** if the opening of the “U” shape of the crossmember attached to the center bearing is facing downward.

Or,

 - b. The repair **is not required** if the center bearing hanger bracket is spaced away from the crossmember and the bottom leg of the hanger bracket is pointed toward the rear of the vehicle.
 - c. If the repair is not required, file an inspection only, no repair required claim.

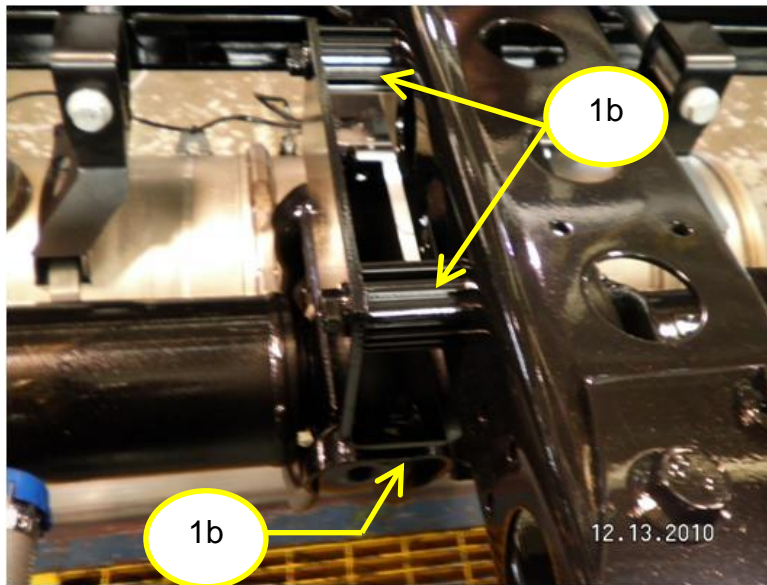

2. Disconnect the rear driveshaft from the front driveshaft.
3. Remove the yoke nut from the front driveshaft.
4. Mark the yoke to the driveshaft before removing the yoke to ensure the proper phasing of the driveshaft upon installation of the yoke.



5. Remove the yoke.
6. Support the front driveshaft with a strap or jack stand.
7. Remove the two bolts holding the center bearing to the hanger bracket.
8. Replace the center bearing.
 - a. The center bearing should slide off from the shaft
 - b. If the center bearing does not slide off use the appropriate puller.
9. Remove the hanger bracket.
10. Install two new bolts through the crossmember, through the spacer, and through the new hanger bracket.
 - a. The bottom of the bracket must face toward the rear of the vehicle

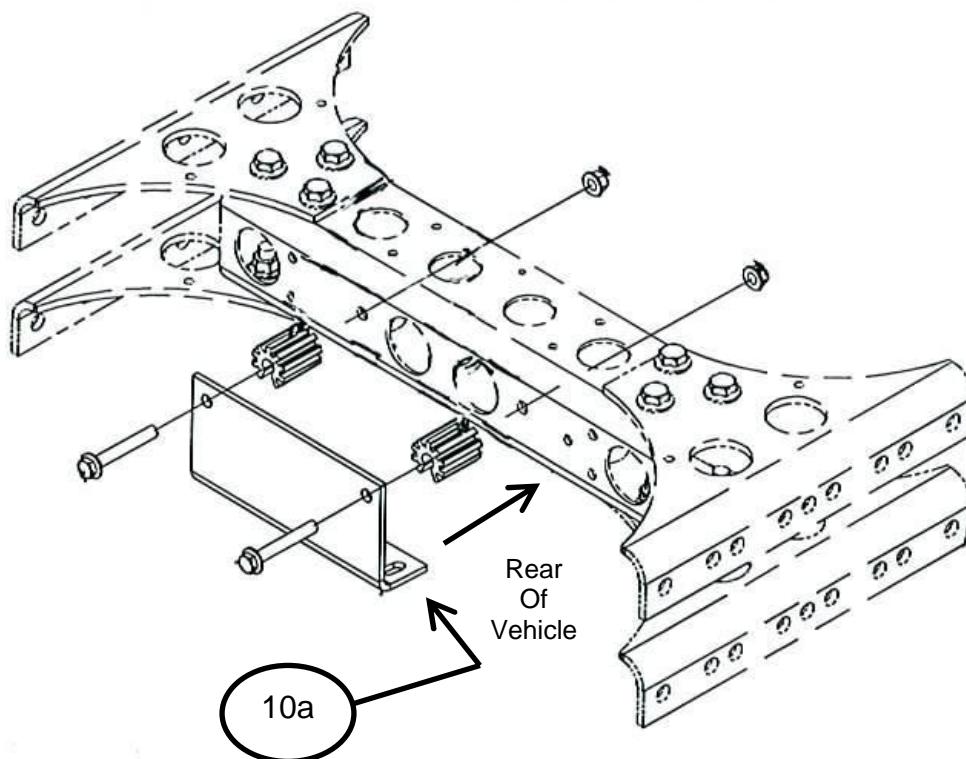

11. Tighten the new hanger bracket bolts to 100 – 120 lbs-ft.

12. Raise the drive shaft and install the two bolts through the center bearing and the hanger. Tighten bolts to 100 – 120 lbs-ft.
13. Make sure that the rubber tabs are centered in the slots on the sides and bottom of the hanger bracket.

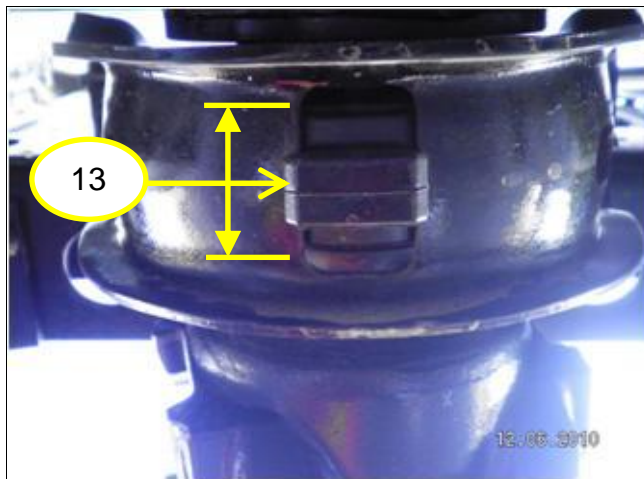
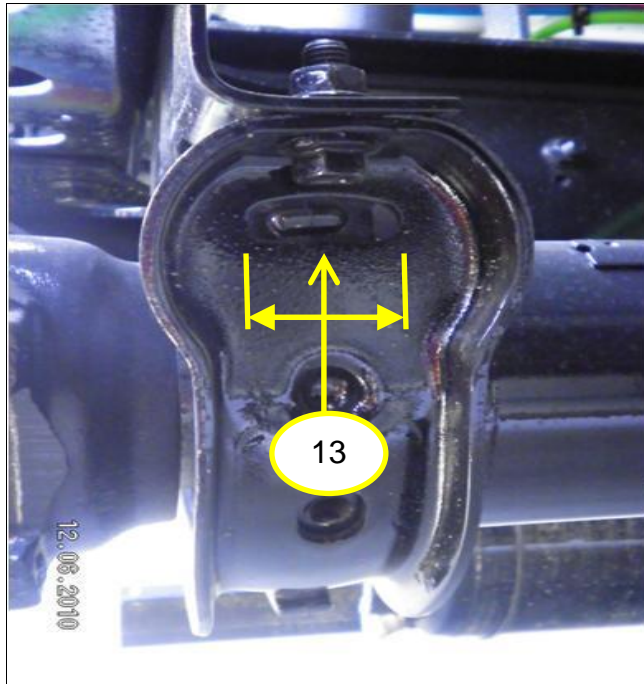

14. Install the yoke using the marking made from step 4. to ensure the driveline is in phase.
15. Install and tighten the yoke nut to 500 lbs-ft.

16. Tighten the center bearing bolts to 100 – 120 lbs-ft.
17. Remove the support that was used to hold the driveshaft.
18. Install the rear driveshaft using new hardware for the u-joint. Tighten the driveline strap bolts to 115 – 135 lbs-ft.
19. Paint the parts installed using a spray can.

END OF SERVICE PROCEDURE

LABOR INFORMATION

Operation Number	Description	Time
A40-10520-1	Inspection Only – No Repair Required	0.2
A40-10520-2	Inspection and R&R Center Bearing and Hanger Bracket	1.3
	AFC Handling Allowance	\$50.00

CAMPAIGN IDENTIFICATION LABEL

Each vehicle corrected in accordance with this campaign must be marked with a CTS-1075 Campaign Identification Label.

Complete the label and attach on a clean surface next to the vehicle identification number (VIN) plate.

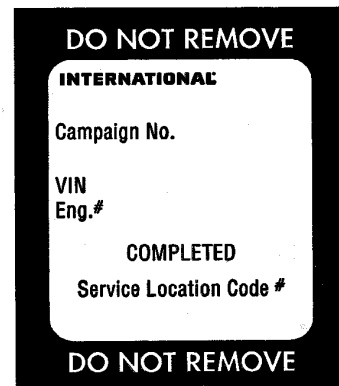

ADMINISTRATIVE/DEALER RESPONSIBILITIES

WARRANTY CLAIMS

Refer to Dealer Warranty Manual for procedures to conduct Recall Campaigns.

Include the AFC Handling Allowance in the “Other” section of the warranty claim.

It is important that the Recall Coding be completed properly to assist in processing the warranty claim. Complete instructions will be found in the Warranty Manual, Section 7-1. Special attention should be given to Items 39 through 44:

	GROUP	NOUN	C	WARR.	TP	PAD
GROUP Enter number G—						
NOUN Leave blank						
C (CAUSE) Enter either 1, 2, 3. (see below)						
1. Inspected (No repair required).						
2. Inspected and repaired.						
3. Defective part from parts stock.						
WARRANTY (Warranty Code) Enter 40.						
TYPE PART Enter P for type part causing failure.						
PAD Enter 100						

UNITED STATES AND POSSESSIONS

The National Traffic and Motor Vehicle Safety Act, as amended, provides that each vehicle that is subject to a vehicle recall campaign must be adequately repaired within a reasonable time after the owner has tendered it for repair. A failure to adequately repair within 60 days after a tender of a vehicle is prima facie evidence of failure to repair within a reasonable time. If the condition is not adequately repaired within 60 days, the owner may be entitled to replacement with an identical or reasonable equivalent vehicle at no charge, or to a refund of the purchase price less a reasonable allowance for depreciation.

Dealers must correct all vehicles subject to this campaign at no charge to the owner, regardless of mileage, age of vehicle, or ownership, from this time forward.

Dealers should proceed immediately to make necessary correction to units in inventory. All inventory vehicles subject to this recall campaign must be corrected prior to sale, transfer or delivery. If vehicles have been sold or transferred and you are in receipt of Customer Notification Letters and Authorization for Recall Service cards for those vehicles, the transfer location or customer must be notified immediately from your dealer location.

Dealers must make every effort to promptly schedule an appointment with each owner to repair his or her vehicle as soon as possible. However, consistent with the customer notification, dealers are expected to complete the repairs on the mutually agreed upon service date.

Dealers involved in the recall process will be furnished a listing of owner names and addresses to enable them to follow up with owners and have the vehicles corrected. Use of this listing must be limited to this campaign because the list

may contain information obtained from state motor vehicle registration records and the use of such motor vehicle registration data for purposes other than this campaign is a violation of law in several states.

CANADA

Dealers must correct all vehicles subject to this campaign at no charge to the owner, regardless of mileage, age of vehicle, or ownership, from this time forward.

Dealers should proceed immediately to make necessary correction to units in inventory. All inventory vehicles subject to this recall campaign must be corrected prior to sale, transfer or delivery. If vehicles have been sold or transferred and you are in receipt of Customer Notification Letters and Authorization for Recall Service cards for those vehicles, the transfer location or customer must be notified immediately from your dealer location.

Dealers must make every effort to promptly schedule an appointment with each owner to repair his or her vehicle as soon as possible. However, consistent with the customer notification, dealers are expected to complete the repairs on the mutually agreed upon service date.

Dealers involved in the recall process will be furnished a listing of owner names and addresses to enable them to follow up with owners and have the vehicles corrected. Use of this listing must be limited to this campaign because the list may contain information obtained from state motor vehicle registration records and the use of such motor vehicle registration data for purposes other than this campaign is a violation of law in several states.

EXPORT

Export Distributors should proceed immediately to make necessary correction to units in inventory. All inventory vehicles subject to this recall campaign must be corrected prior to sale, transfer or delivery. If vehicles have been sold or transferred and you are in receipt of Customer Notification Letters and Authorization for Recall Service cards for those vehicles, the transfer location or customer must be notified immediately from your distributor location.

Export Distributors are to submit warranty claims in the usual manner making reference to this recall number.

Export Distributors are expected to provide full cooperation and follow-up with respect to this important subject matter. If you have any questions or need further assistance, please contact the Regional Service Manager at your regional office.

NAVISTAR, INC