

# SERVICE BULLETIN

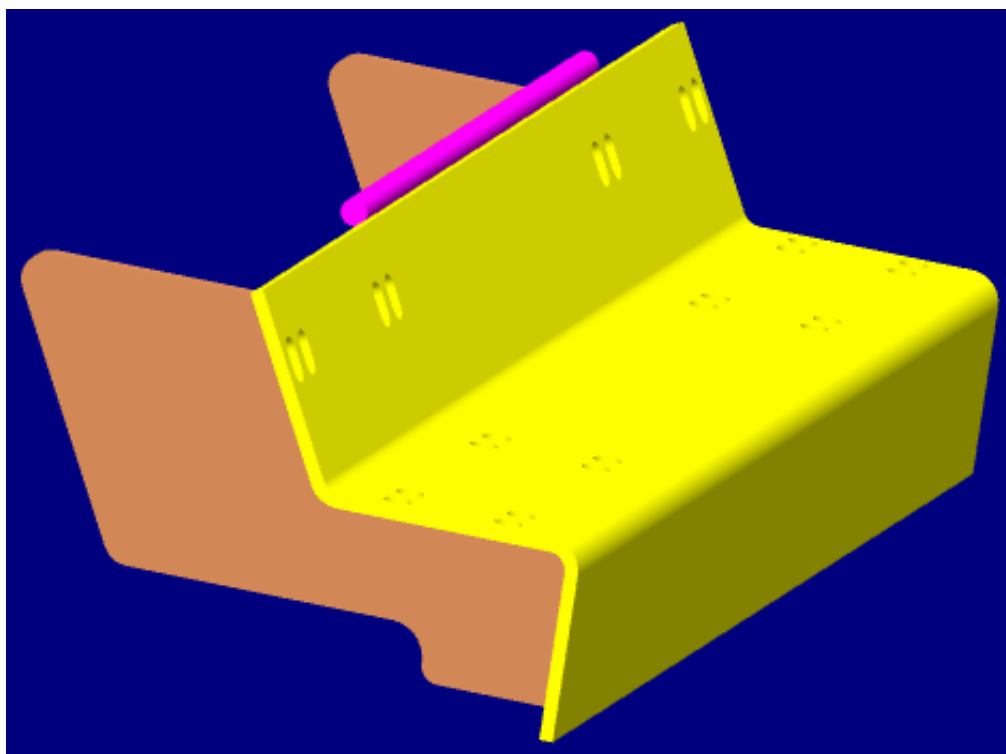

## Service Bulletin #227 December 23, 2009

### Rapid Rail/CP Python Bolt-On Hinge Assembly Inspection & Reinforcement Procedures



Heil Environmental bulletins are intended for use by professional technicians, NOT a "do-it-yourselfer." They are written to inform experienced technicians of conditions that may occur on some units, or to provide information that could assist in the proper servicing of a unit. Properly trained technicians have access to and are familiar with the applicable Heil Parts & Maintenance Manual and have the equipment, tools, safety training, and know-how to do a job properly and safely. If a condition is described, DO NOT assume that the bulletin applies to your unit, or that your unit will have that condition. See your Heil Dealer for information on whether your unit may benefit from the information.

**NOTE: READ THIS BULLETIN IN ITS ENTIRETY BEFORE BEGINNING ANY REPAIR WORK**

### **General Information**

The purpose of this document is to provide inspection and reinforcement procedures for the bolt-on hinge assembly used on certain Rapid Rail and CP Python units. The inspection and reinforcement will only affect units as identified below.

Heil has recognized the potential for cracking in the welds of the RH (curb-side) flange of the rear body hinge assembly that is bolted to the chassis. There is also a possibility for cracks to develop in the right or left hand flange plate (reference **Fig. A**). As a result, it is necessary to inspect the 005-4841, bolt-on Hinge Base Weldment where applicable.

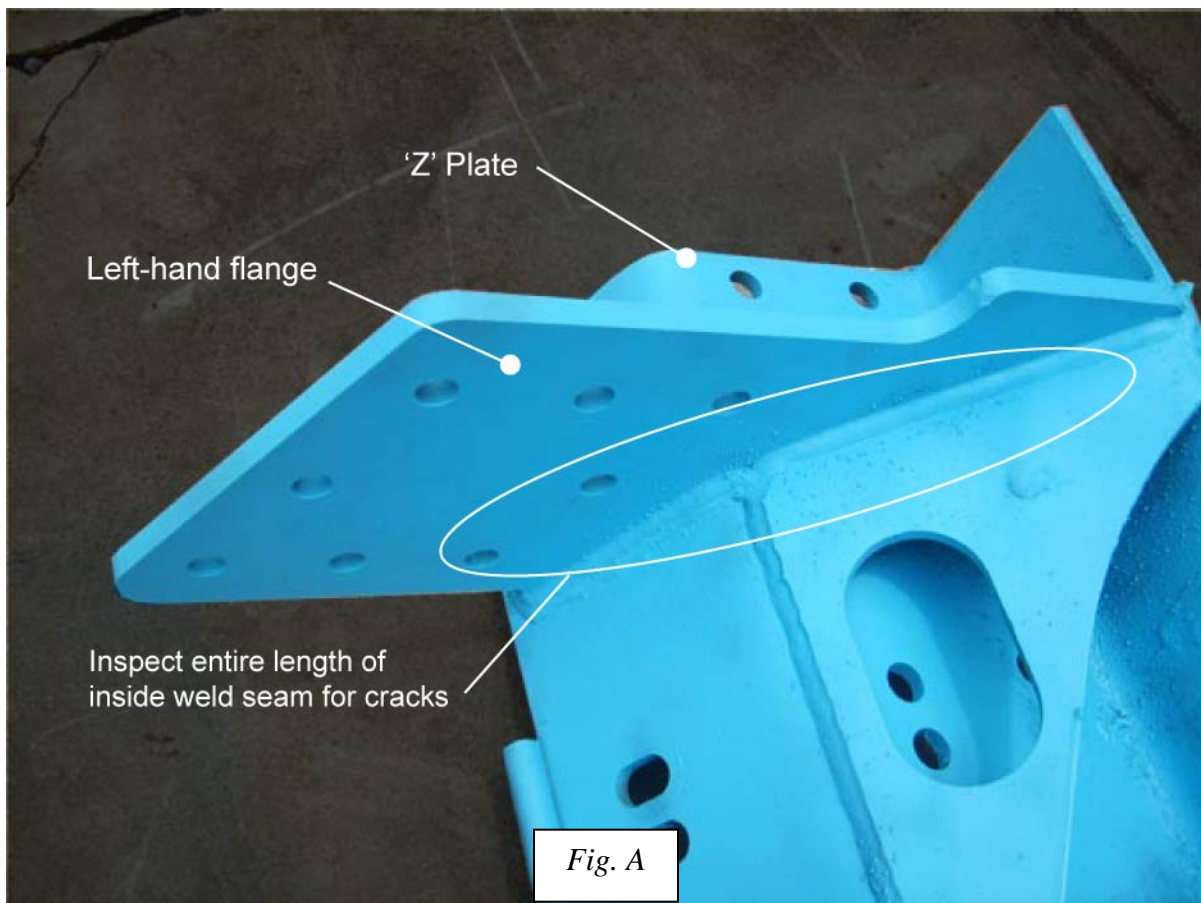

This limited potential for cracking has thus far only been isolated to applications where the closest chassis cross-member is more than 30” beyond the forward edge of the “Z” plate used in the Hinge Base Weldment. (See **Fig. B**) The frequent movement of the chassis rail during normal operation results in flexing of the side flanges of the Hinge Base Weldment which can lead to fatigue in the “Z” plate welds and/or right and left hand flanges.

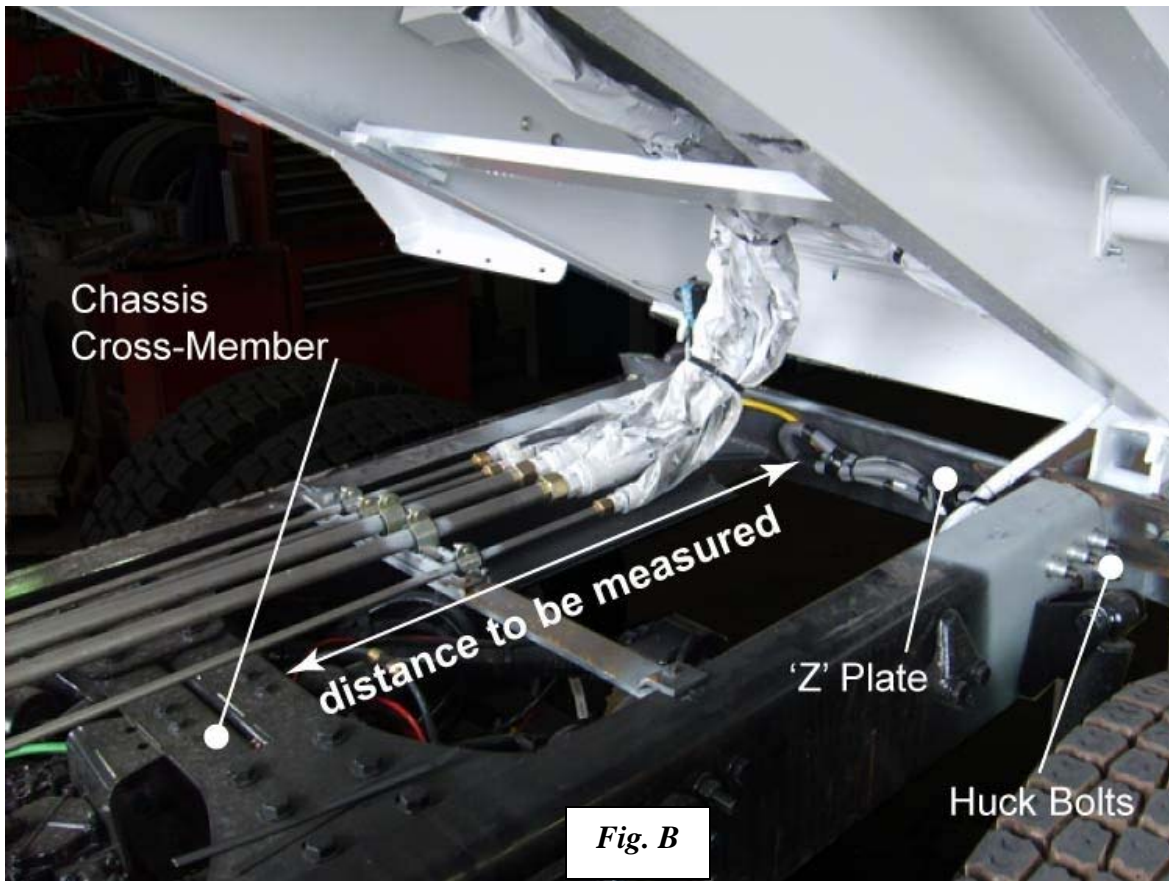

The need for inspection and reinforcement does not affect all Rapid Rails and CP Pythons currently operating in the field. Affected units shipped between January 1, 2006 and July 31, 2009 with 26, 30 or 32 cubic yard bodies. The potentially affected body serial numbers have been provided to each dealer in a separate document. None of the 16, 20, 22 or 24 cubic yard bodies are affected as all of these body sizes were mounted using the full welded hinge design. The bolt-on hinge assembly has been the standard for the 26, 30 and 32 cubic yard bodies since January 1, 2006. However, some of the 26, 30 and 32 cubic yard bodies may have been mounted with full welded hinges, because some of these applications did not allow adequate chassis rail length and clearance for the installation of the bolt-on hinge assembly.

## **Inspection Procedures**

### **Exclusions**

Not all units require a detailed inspection of the rear hinge assembly. Units excluded from the inspection requirement are as follows:

- All 16, 20, 22 and 24 cubic yard bodies are excluded.
- All 26, 30 and 32 yard bodies with fully welded hinges are excluded.
- All 26, 30 and 32 yard bodies with bolt-on hinge assemblies that already have gussets installed are excluded. It is important to note that existing field units may only have had one gusset per side installed at the factory. This is acceptable.

### **Required**

Use the following steps to determine whether or not the rear hinge assembly may require a detailed inspection.

- Refer to the serial number list in the reference section of this document (supplemental dealer-specific list).
- If the unit serial number is found to be within the ranges identified on the serial number list provided, use the comparison of the bolt-on and full welded hinge assemblies provided on page 5 to determine which hinge assembly is installed. Reference figures 1 thru 4 on page 5 for the bolt-on and full welded assemblies.
- A detailed inspection of the hinge welds is required, if the hinge assembly is of the bolt-on style as shown in figures 1 and 2. Refer to the section titled "Detailed Inspection" for information on the comprehensive inspection process to be used for the bolt-on hinge assembly.

## Bolt-On Hinge Assembly (Must be Inspected)

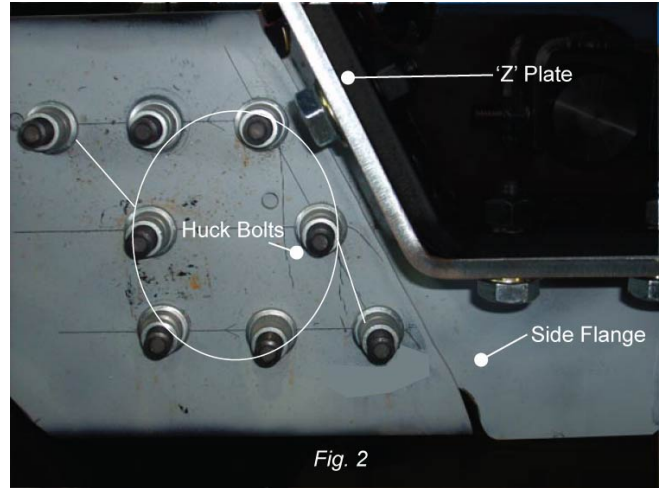
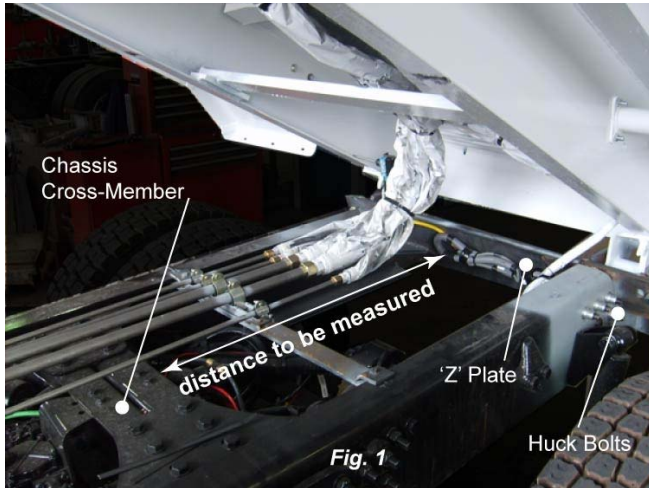

## Weld-On Hinge Assembly (Excluded from Inspection)

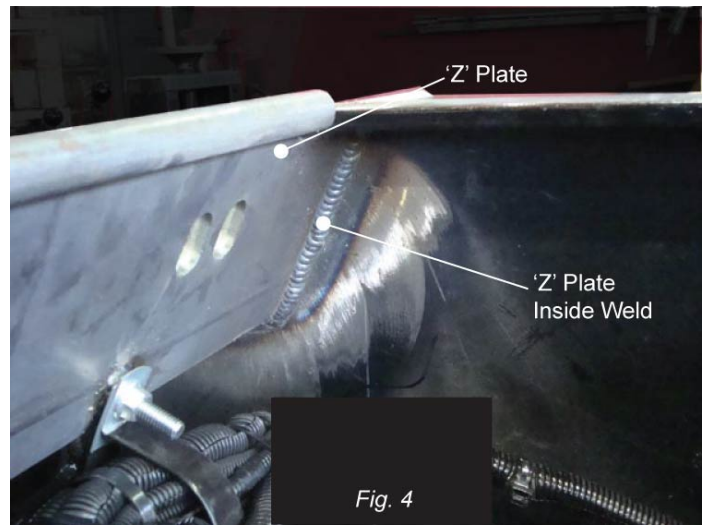
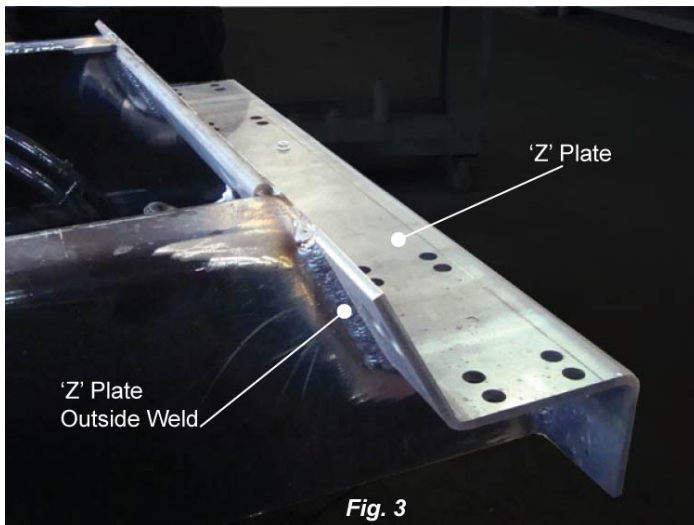

## Detailed Inspection Process: Bolt-On Hinge Assembly

**WARNING: FAILURE TO STRICTLY FOLLOW THESE INSTRUCTIONS COULD RESULT IN INJURY OR DEATH.**

- **REMOVE THE KEYS FROM THE VEHICLE AND USE LOCK-OUT/TAG-OUT PROCEDURES BEFORE PERFORMING ANY INSPECTIONS OR REPAIRS.**
- With the body in the lowered position, inspect the rear hinge area for visible cracks, loose components or any other notable damage. If any of these conditions are identified, red tag the unit and take it out of service immediately. Do not place the unit back into active service until the problems identified are corrected, in accordance with the procedure outlined below.
- Place the unit on level and stable ground before proceeding any further, and ensure the hopper and body are free of trash.
- Once it has been determined that it is safe, raise the body and lower it onto the body props.
- Clean the rear body hinge area at the rear of the vehicle. Pressure wash the hinge assembly, if necessary, to remove any caked on debris. If needed, use a wire brush to remove loose paint and excess debris.
- Inspect all of the welded surfaces of the right and left hand side flanges as shown on Page 7. (See **Fig. 5 & Fig. 6**). It may be necessary to use some form of auxiliary lighting to properly illuminate areas to be inspected. **Cracks may not be open and, thus, could be difficult to see.** It is important to note that cracks can develop at the edges of the welds as well as in the un-welded parent material of the left or right hand flange. Perform the inspection looking directly into the joint, moving forward and rearward at various angles to the weld and chassis frame.
- Inspect the exposed surfaces of the right and left hand side flanges for cracking. (See **Figs. 7, 8, 9, & 10** for areas that may experience cracking.)

**Hinge Mount - Outside**

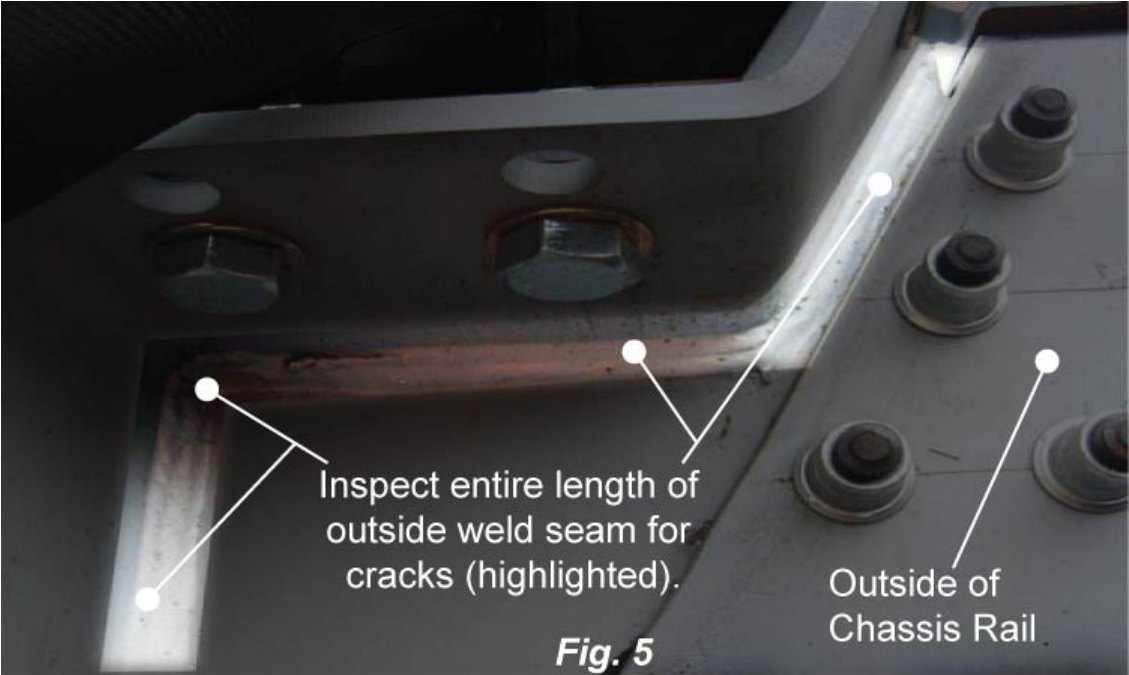

**Hinge**

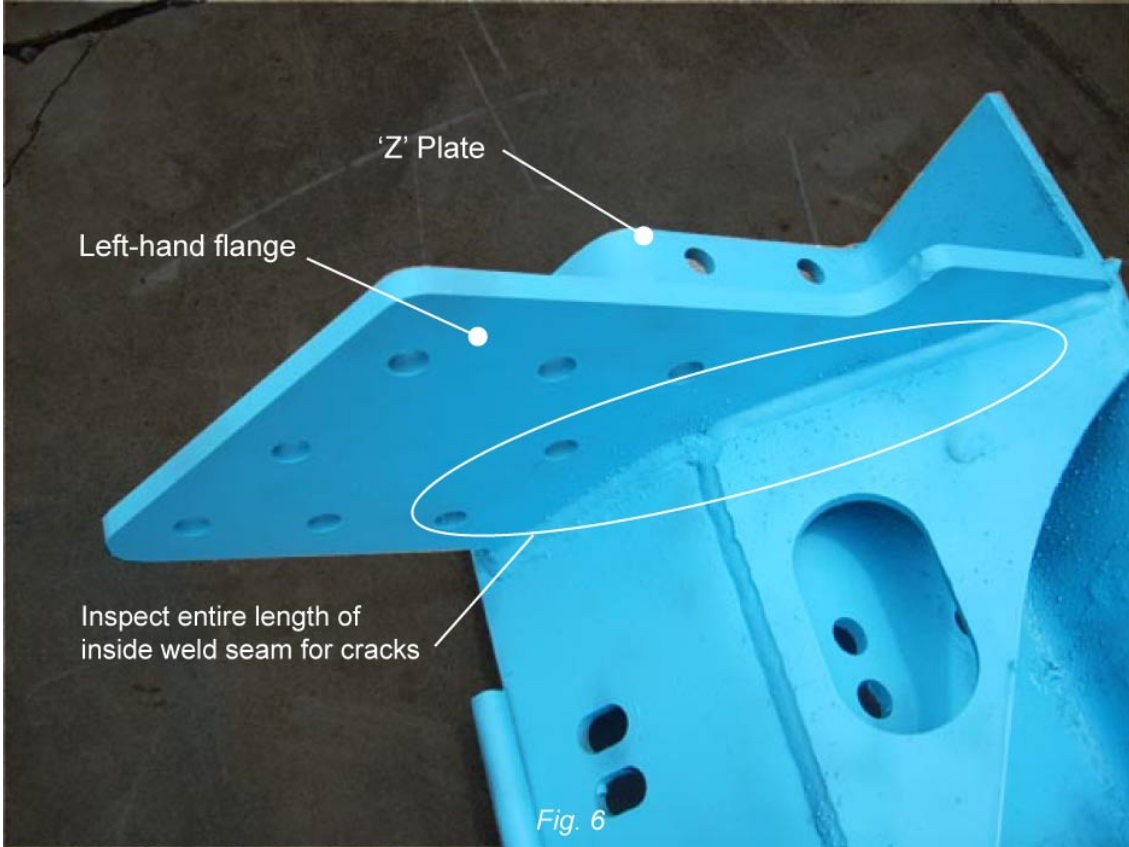

Mount - Inside

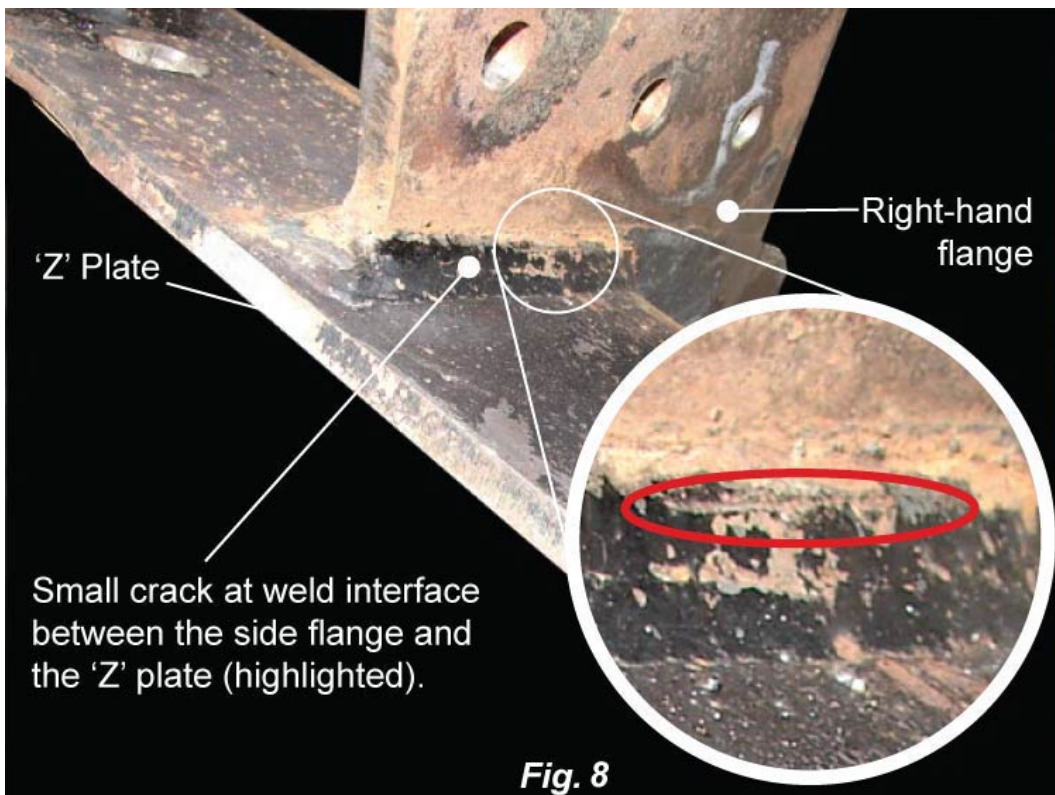
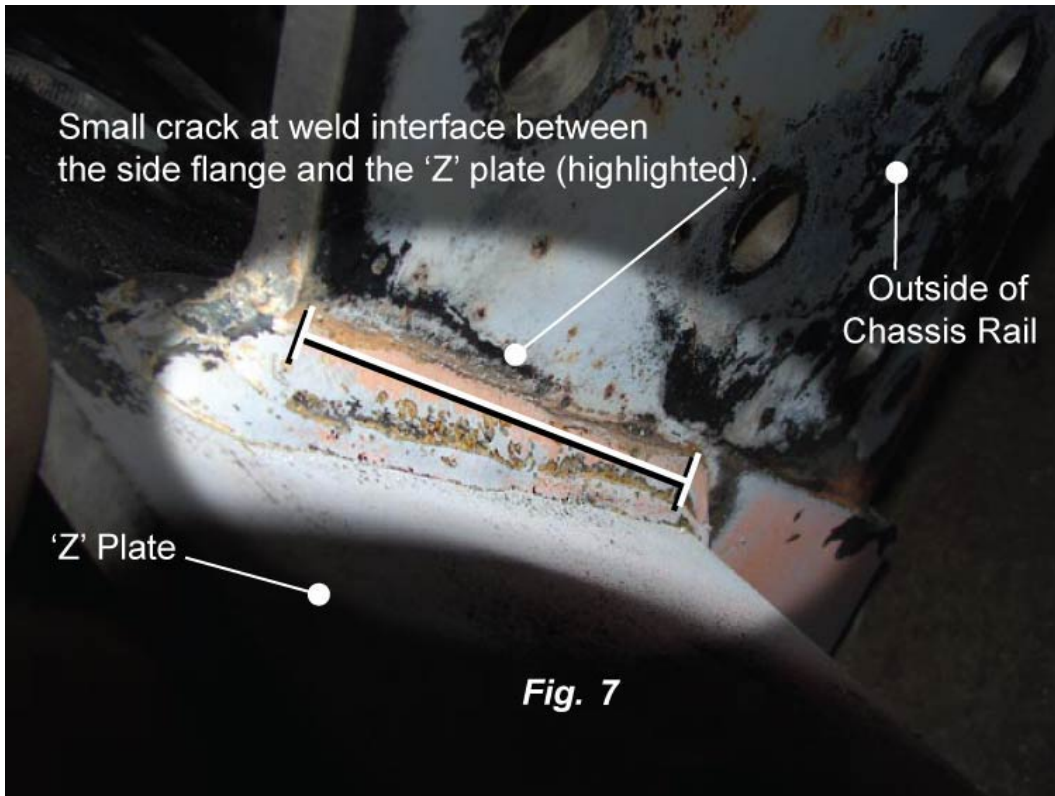

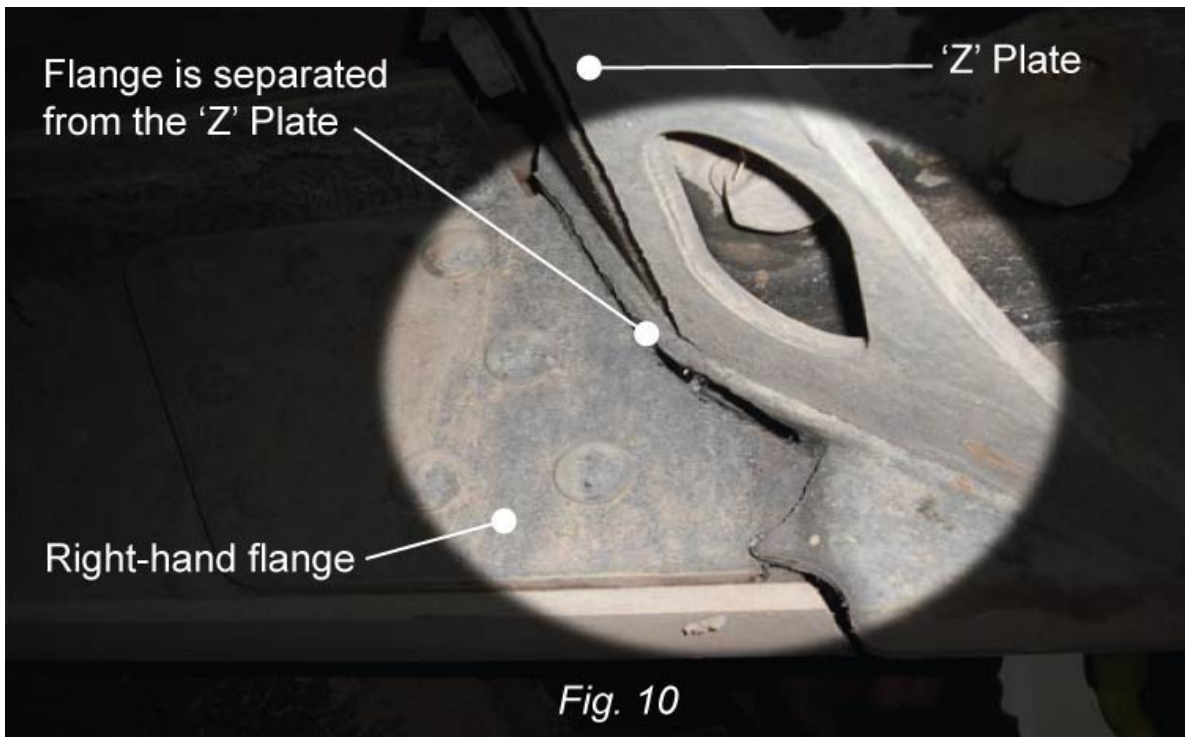
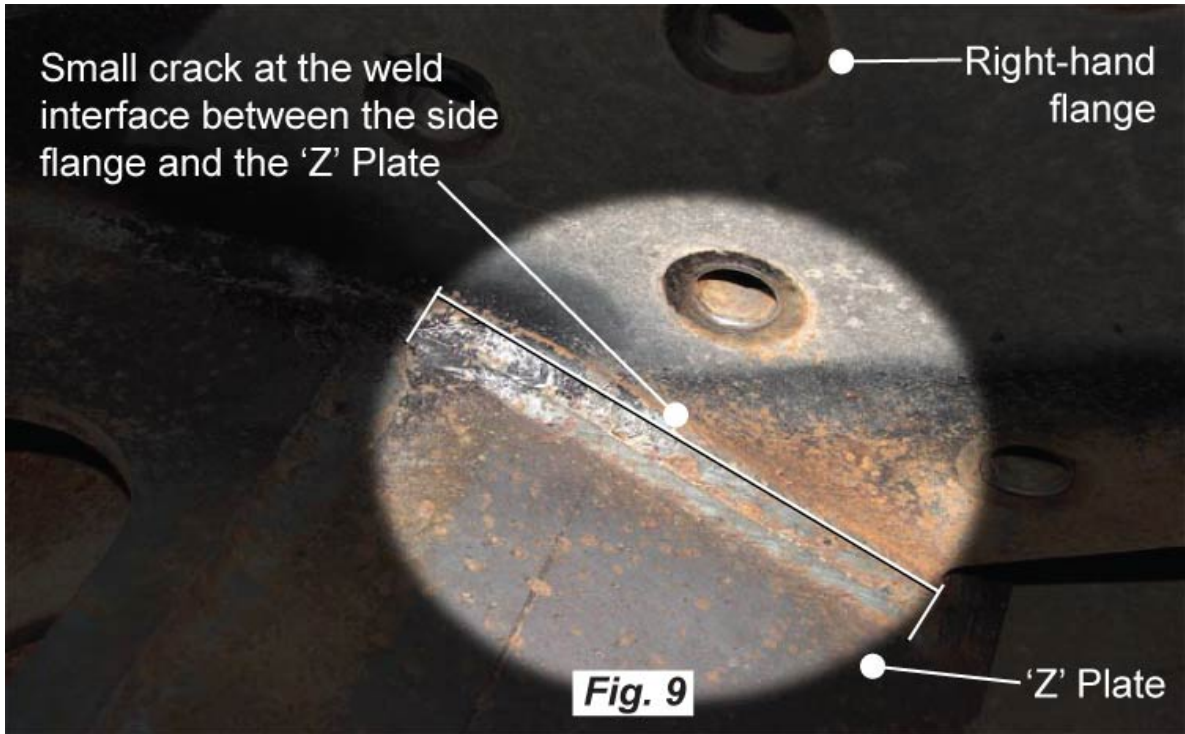

## Identified Cracks

If any units are found to have cracking in welds at the interface of the “Z” plate and the right or left hand flanges and/or the material of either flange, contact your assigned **Heil Customer Support Team at 866.ASK.HEIL (866.275.4345)**.

## Adding Reinforcement

If there is not any cracking found in the welds or flanges of the hinge assembly, it will still be necessary to install gussets to reinforce the hinge assembly to prevent flexing of the left and right hand flanges. (See **Fig. 11** & **Fig. 12**, below.)

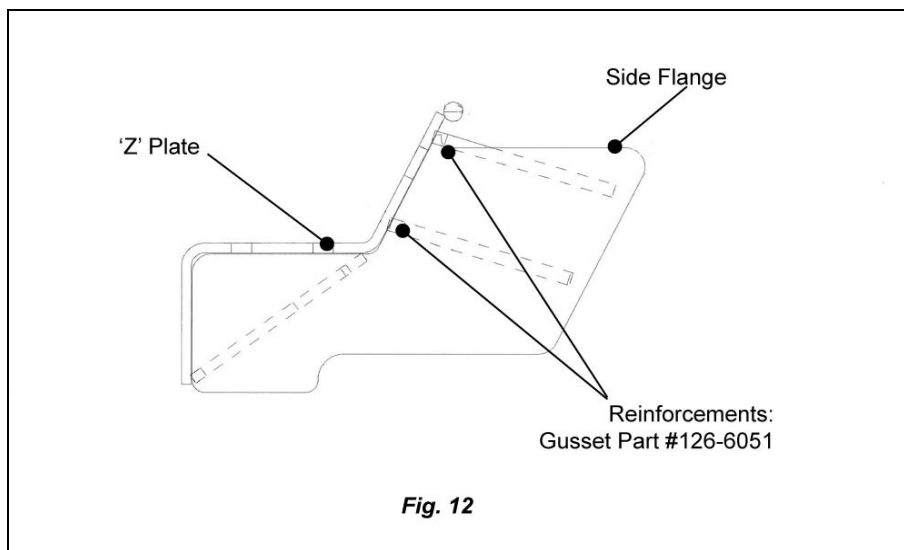
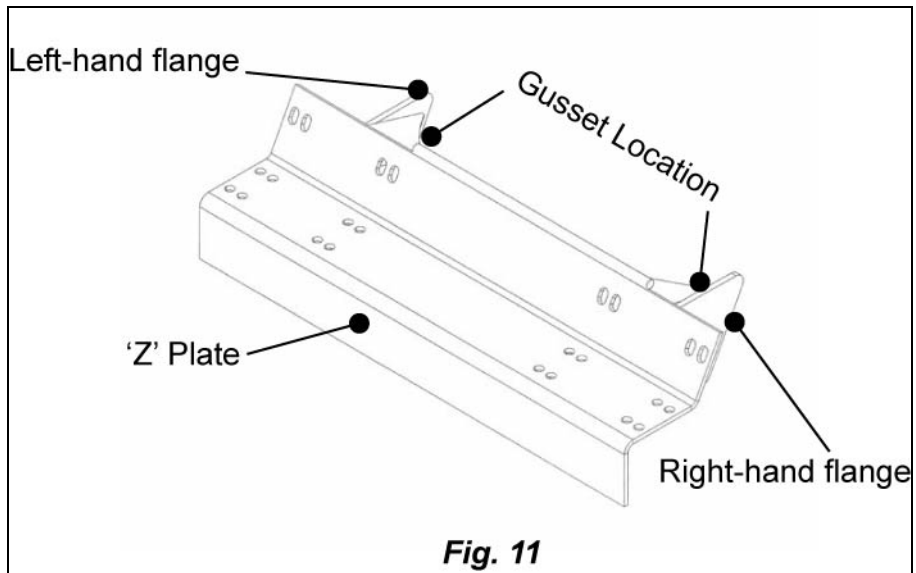

Follow the procedures below and on the following pages for installation of the 126-6051 gussets. Removal of the Hinge Base Weldment is not required for the installation of the gussets.

**IMPORTANT:** Failure to follow these procedures may cause damage to electronic devices. The damage comes from the inability of the devices to withstand the amperage, open circuit voltage and magnetic flux a welder can produce.

- **REMOVE THE KEYS FROM THE VEHICLE AND USE LOCK-OUT/TAG-OUT PROCEDURES BEFORE PERFORMING ANY INSPECTIONS OR REPAIRS.**
- Prep the applicable areas of the flanges and the “Z” plate to ensure the surfaces to be welded are free of any paint, oil, grease or dirt. (Shown in **Fig. 13** and **Fig.14**)

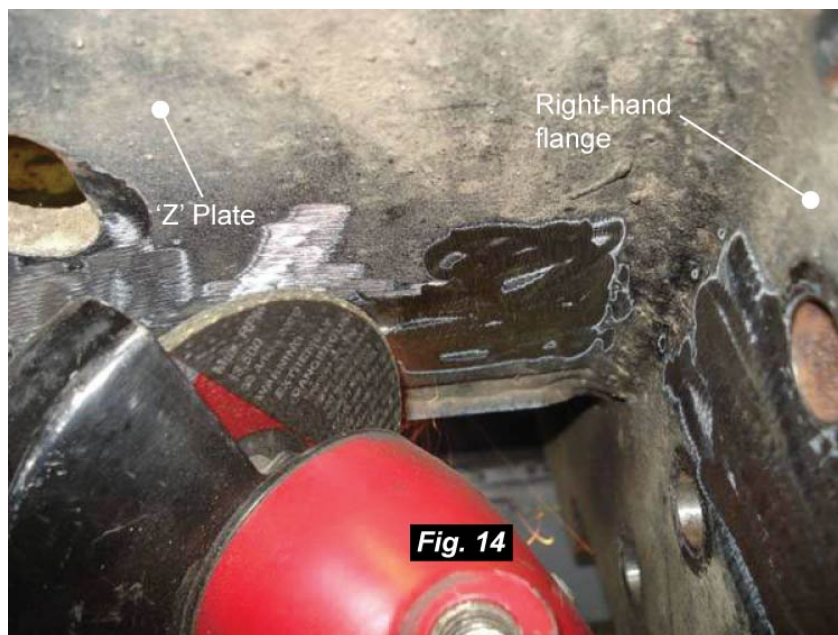
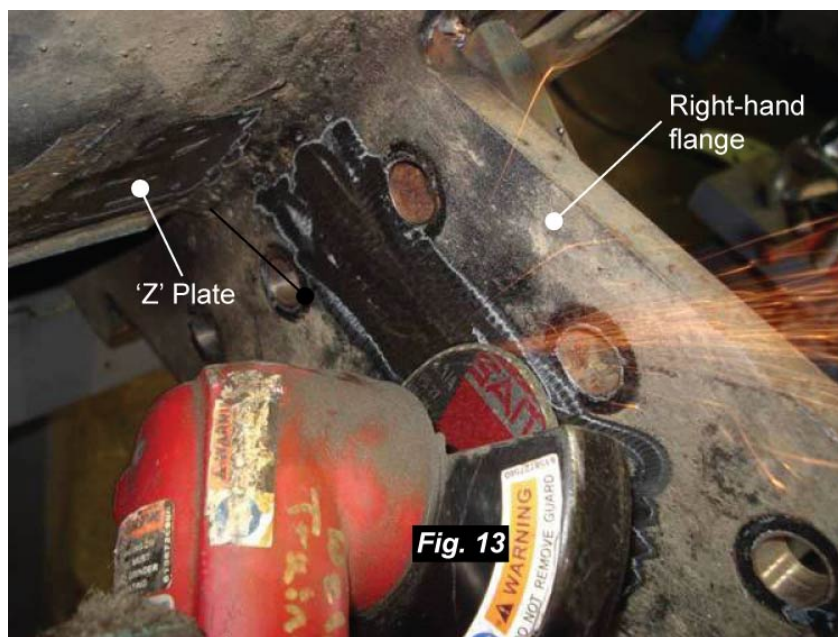

- To optimize the location of the gusset, it will be necessary to secure any loose electrical or hydraulic routings for increased clearance and access.
- Before welding on any unit with electronic devices like PLC's, proximity switches and electronic control units (ECU's), complete the following instructions\*.
  - Disconnect all battery connections.
  - Place the welding ground as close as possible to the area that is being repaired.
  - Disconnect all PLC's and ECU's\*.
  - If welding within 24 inches of a proximity switch, remove the switch from the unit.

\*Proper installation and use of an approved automotive surge protector, such as the Antizap Service Minder (model ET20AZ), will prevent the need to disconnect PLC's and ECU's.
- Two gussets are to be welded to each side of the Hinge Base Weldment for a total of four gussets per unit.
- See attachment **R1**, on page 15, of the reference section for details on welding equipment types and required settings.
- Once the applicable areas have been prepared for welding, locate the top gusset as close as possible to the top edge of the Z" Plate and flange. (See page 13, **Fig. 15**) Bolt hole locations will dictate placement of the upper gusset.
- Referencing **Fig. 15**, be sure that both sides of the 126-6051 gusset that adjoin to the "Z" Plate and the flange are completely welded along each edge. A single pass weld is required. If there is enough room to access the top of the gusset, place two 1" – 2" skip welds along each edge of the plate.
- Locate the lower gusset as close to the bottom edge of the Z" Plate and flange as possible. Bolt hole locations will dictate placement of the lower gusset. (See **Fig. 16** on next page.). Be sure that both sides of the 126-6051 gusset that adjoin to the "Z" Plate and the flange are completely welded along each edge. A single pass weld is required. If there is enough room to access the top of the gusset, place two 1" – 2" skip welds along each edge of the plate.

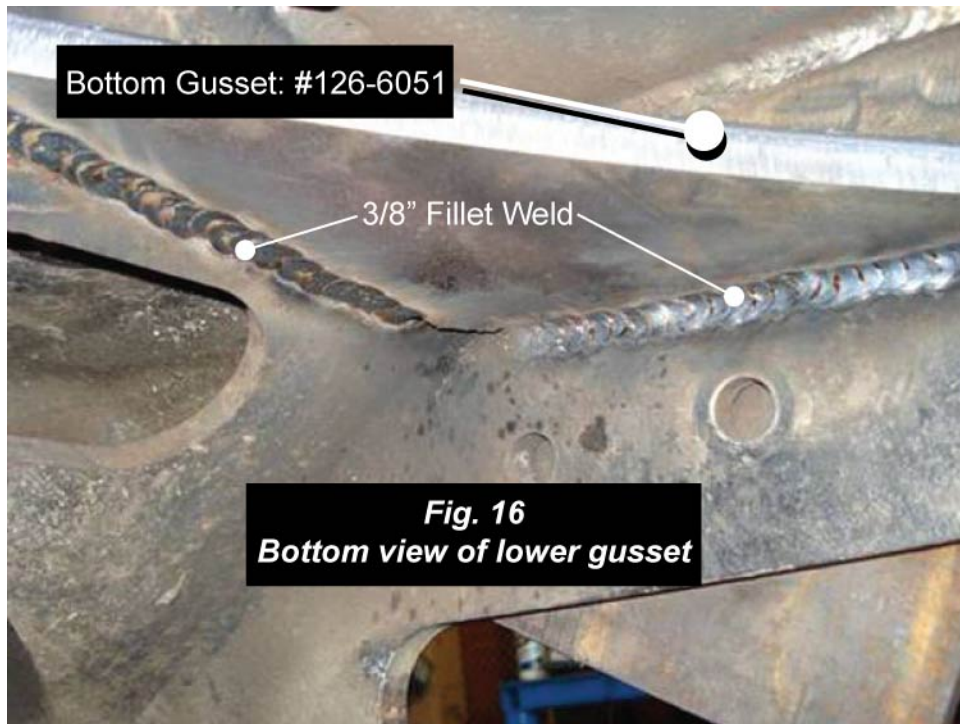
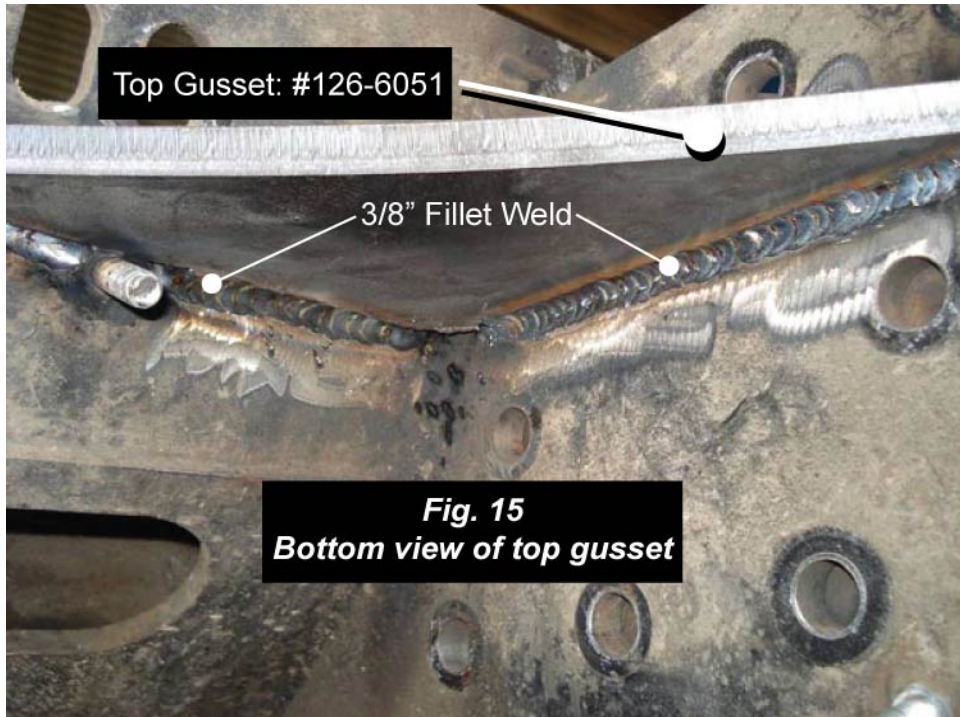

### **Ordering Replacement Parts & Reimbursement:**

The four 126-6051 gussets required to reinforce the Hinge Base Weldment must be ordered through Heil Parts Central. In order to obtain reimbursement from Heil for the parts, submit one completed Request For Credit (RFC) form for each unit reworked to Heil's Customer Support Team. Labor for the inspection and installation of the reinforcements will be reimbursed at three hours per unit. Claims must be filed electronically using Heil's on-line warranty system. It is important to reference campaign code 903 in the WRO block of the claim form. In order to receive warranty coverage for the repairs described in this bulletin, all repairs must be completed by March 31, 2010.

If you have any questions regarding the information detailed in this bulletin, please contact your assigned **Heil Customer Support Team at 866.ASK.HEIL or (866.275.4345).**

# Attachment R1

									
Weld Procedure									
SMAW (Stick Electrode)									
ER6010					ER7018				
Electrode Diameter		Amps	Polarity		Electrode Diameter		Amps	Polarity	
5/32		170	DC+		1/8		130	DC+	
3/16		170	DC+		5/32		160	DC+	
GMAW (MIG)									
ER70S-X .045					ER70S-X .035				
Volts	Wire Feed Speed		Polarity		Volts	Wire Feed Speed		Polarity	
27-32	450 - 525		DCEP		27-32	450 - 525		DCEP	
<b>Welding Notes:</b>									
1. All material shall be free from paint, oil, grease, dirt, and any other non-metal contamination.									

## Attachment R2

Each dealer has received a spreadsheet containing a list of all units that require inspection. The current end user names and locations as identified by Heil are provided for each unit. The supplied list does not include any units that have already been repaired or reworked.

There are several columns in the spreadsheet that are to be completed upon inspection of each unit as detailed below.

Customer ID #	Inspection Date	Bolt-On or Welded Hinges	Factory Gussets (Y/N)	Cracks Identified (Y/N)	Hinge to Chassis XM	Inspector	Gussets Installed (Y/N)	Rework Complete (Y/N)
---------------	-----------------	--------------------------	-----------------------	-------------------------	---------------------	-----------	-------------------------	-----------------------

- Customer ID # - This is the identification number that the end user has assigned to the equipment.
- Inspection Date -The actual date of the hinge inspection.
- Bolt-On or Welded Hinges – Identify which type hinge each is installed on each unit. Enter “Bolt-On” for the bolt on type and “Welded” for the full welded hinges. Reference figures 1 thru 4 on page five.
- Factory Gussets (Y/N) – Indicate whether or not the bolt-on hinge assemblies have factory installed gussets. Reference figures 11 and 12 on page 10, and figures 15 and 16 on page 13.
- Cracks Identified (Y/N) – Indicate whether or not visible cracks are found in the bolt-on hinge assemblies that are inspected.
- Hinge to Chassis XM – This is the distance between the top edge of the “Z” plate and the closest chassis cross-member. See figures R2-1 thru R2-4 on pages 17 and 18 of the reference section.
- Inspector – List the name of the person performing the inspection
- Gussets Installed (Y/N) – This column is used to confirm the field installation of gussets to the bolt on Hinge Base Weldment.
- Rework Complete (Y/N) – indicate whether or not any repair or rework is complete. Be sure to update this column as any repairs or rework is completed.

Note: Some of the columns referenced above may have information in the cells. This information was collected during Heil’s initial field inspections. This data is a result of population sampling inspections performed by Heil Field Technicians

The information requested must be supplied with each update submitted to Heil. Submit inspection updates at the beginning of each month to the regional Customer Support team, via e-mail. The individual team e-mail addresses are listed below. Please change any end user addresses, chassis make, chassis Vin numbers, etc that are found to be incorrect.

Regional Team

North Atlantic & New England  
 South Central & Southeastern  
 West/Midwest

E-mail Address

[nanecustomersupport@heil.com](mailto:nanecustomersupport@heil.com)  
[scsecustomersupport@heil.com](mailto:scsecustomersupport@heil.com)  
[wmcustomersupport@heil.com](mailto:wmcustomersupport@heil.com)

### Chassis XM Measurement & Additional Information

- Measure the distance from the rear hinge and the closest chassis cross-member as shown in figures R2-1 through R2-4.
- Identify Chassis Make and Model
- Identify Suspension Make and Model (Front & Rear)

