

MERITOR[®]
an *ArvinMeritor* brand

Technical Bulletin

Lower Axle Seat Weld Inspection and Repair for Meritor RideSentry™ MPA Series Sliding Tandem Trailer Air Suspension Systems

Hazard Alert Messages

Read and observe all Warning and Caution hazard alert messages in this publication. They provide information that can help prevent serious personal injury, damage to components, or both.

⚠ WARNING

To prevent serious eye injury, always wear safe eye protection when you perform vehicle maintenance or service.

Park the vehicle on a level surface. Block the wheels to prevent the vehicle from moving. Support the vehicle with safety stands. Do not work under a vehicle supported only by jacks. Jacks can slip and fall over. Serious personal injury and damage to components can result.

How to Obtain Additional Maintenance and Service Information

Refer to Maintenance Manual 14R, RideSentry™ MPA Series Sliding Tandem Trailer Air Suspension System; and Technical Bulletin TP-0777, Installing RideSentry™ Suspension Axle Seats onto RideStar™ RHP Series Single-Axle and Sliding Tandem Trailer Air Suspension Systems. To obtain these publications, visit Literature on Demand at arvinmeritor.com.

Inspection Procedure

1. Wear safe eye protection. Park the vehicle on a level surface. Block the wheels to prevent the vehicle from moving.
2. From underneath the trailer, inspect the lower axle seat welds as follows.
 - A. Check that there are a total of four welds per axle seat side (two lower axle seats welded on each side). Figure 1.
 - B. Verify the welds are nominally 1.5-inches (38 mm) long and 0.25-inch (6.35 mm) wide on each side of the lower axle seat onto the axle. The welds should not be more than 1.5-inches (38 mm) long. Figure 2.

- **If any welds are missing or incomplete:** Call ArvinMeritor's OnTrac Customer Service Center at 866-OnTrac1 (668-7221) for repair authorization. Refer to Contact the ArvinMeritor OnTrac Customer Service Center at the end of this bulletin. Once you receive authorization, perform the Weld Repair Procedure in this bulletin.

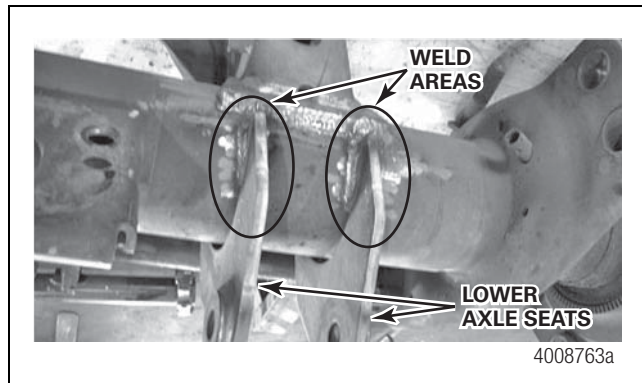

Figure 1

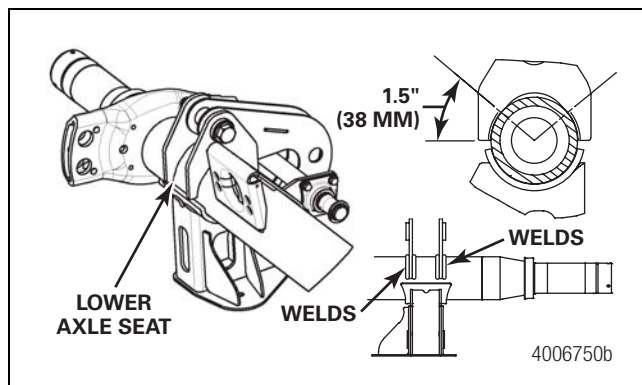

Figure 2

3. Inspect the lower axle seat welds on the other end of the axle using the same procedure.

Weld Repair Procedure

⚠ WARNING

You must follow correct welding procedures and weld at locations authorized by Meritor when you weld to suspension components. Welding at locations other than those authorized by Meritor will void the warranty and can reduce trailer axle fatigue life. Serious personal injury and damage to components can result.

Wear safe clothing and eye protection when you use welding equipment. Follow instructions provided by welding equipment manufacturers to prevent serious personal injury and damage to components.

Do not weld over the end of the lower seats. Weld repairs to the axle seat must not extend more than 1.5-inches (38 mm). Welds longer than this specification may result in premature fatigue fractures to the axle tube. Serious personal injury and damage to components can result.

1. Wear appropriate clothing and eye protection when using welding equipment. Refer to Maintenance Manual 8 for complete welding instructions.
2. Use 0.035 E70 wire and 75/25 gas to weld the missing or incomplete areas. Make each weld 1.5-inches (38 mm) long and 0.25-inch (6.35 mm) wide. Welds should not be longer than 1.5-inches (38 mm). Do not weld over the end of the lower seats. Figure 2.
3. When you have finished, verify there is a total of eight complete welds, (two lower axle seats welded on each side). Continue repairs on the other end of the axle, if necessary.

Contact the ArvinMeritor OnTrac Customer Service Center

Call ArvinMeritor's OnTrac Customer Service Center at 866-OnTrac1 (668-7221) (United States and Canada) between 8:00 AM and 8:00 PM ET Monday through Friday, and between 9:00 AM and 6:00 PM ET on Saturday. After selecting "preferred language," select "Option 7." The OnTrac representative will need the following information to give the repair facility the permission to proceed with the work. The OnTrac representative will also provide you with complete parts return information.

- Complete 17-digit vehicle identification number (VIN)
- ArvinMeritor axle model and serial number. Figure 3.
- Vehicle owner's name, address and telephone number
- Vehicle in-service date
- Repair facility's name, address and telephone number
- Repair facility's hourly rate

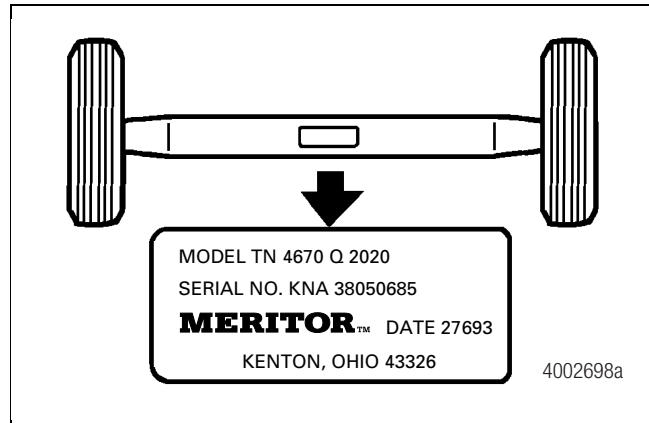

Figure 3

ArvinMeritor™

Meritor Heavy Vehicle Systems, LLC
2135 West Maple Road
Troy, MI 48084 USA
866-OnTrac1 (668-7221)
arvinmeritor.com

Information contained in this publication was in effect at the time the publication was approved for printing and is subject to change without notice or liability. Meritor Heavy Vehicle Systems, LLC, reserves the right to revise the information presented or to discontinue the production of parts described at any time.

Copyright 2010
ArvinMeritor, Inc.
All Rights Reserved

Printed in USA

TP-10172
Issued 09-10
(16579)

10/01/2010

Ken Huff
Vanguard National Trailer Corp
289 East Water Tower Drive
Monon, IN 47959

NOTICE: Defect Information Notice – Certain ArvinMeritor MPA trailer suspension systems manufactured and shipped by ArvinMeritor Inc.

ArvinMeritor File: C10AB

NHTSA File: 10E-047

Dear ArvinMeritor Customer:

This notice is sent to you in accordance with the requirements of the National Traffic and Motor Vehicle Safety Act.

ArvinMeritor has decided that a defect which relates to motor vehicle safety exists in certain ArvinMeritor MPA trailer suspension systems (“Systems”). The Systems were manufactured by ArvinMeritor from April 10, 21010 through June 30, 2010, and include models MPA 20, MPA38 and MPA40.

Description of Defect

The suspect Systems may have missing welds at the interface of lower seat bracket and axle beam, which could allow the axle to roll out of position and thereby potentially impact the handling of the trailer.

NHTSA Notification & Safety Recall Obligations

According to our records, affected units were shipped to your company. If those units were installed as original equipment on vehicles manufactured at your facility, and you agree that they contain a safety defect, your company must notify the National Highway Traffic Safety Administration (NHTSA) within 5 business days and conduct a safety recall of those vehicles. It is critical that the NHTSA guidelines are followed in a timely manner and that your customers are notified to conduct the remedy described below.

IMPORTANT: Some of the affected vehicles may still be in your inventory. Federal law requires you to complete the recall service on these vehicles before delivery. ArvinMeritor will provide replacement or repair for these units prior to delivery to your customers.

You must also submit your draft version of your dealer and customer notices to NHTSA for approval at least 5 days prior to mailing such notification to dealers and owners of potentially affected studs. You may contact NHTSA with questions by sending an email to rmd.odi@dot.gov.

IMPORTANT: Dealer notification by Certified Mail is required by Federal law for all safety recalls. Responsible dealership personnel should be instructed to sign for this Certified Mail without hesitation as it contains urgent safety recall information. Notifications to owners of potentially affected vehicles are by first class mail. Please be advised that the outside of each envelope containing an owner notification letter must be marked “SAFETY RECALL NOTICE” all in uppercase



letters, either in boldface or underlined, and in type that is larger than that used in the address section. A sample of the envelope must be submitted to NHTSA for approval at least 5 business days before mailing to owners.

Recommended Action

ArvinMeritor recommends that owners of trailers originally equipped with suspect Systems be contacted immediately and asked to visually inspect the Systems for any missing welds in accordance with the enclosed service instructions (TP-10172). If it is determined that any weld is missing, the System should be repaired in accordance with those service instructions.

NOTE: Not all lower axle seats require repair. Only repair axle seat welds that are missing by following the identification procedure within the TP-10172.

Affected trailers should be repaired as soon as possible by an authorized repair facility. This replacement program will be managed by ArvinMeritor, and will be at no expense to vehicle owners.

Identification of Affected Parts

The suspect population information containing the suspension serial numbers are attached with this notification. ArvinMeritor is continuing to research shipment records. You may receive a separate notice for additional axle serial numbers from ArvinMeritor.

Vehicle manufacturers are requested to provide VIN information and In-Service Dates for the corresponding suspension serial numbers for tracking field actions. The requested information is to be forwarded to:

Jeremy Tertzakian
Jeremy.Tertzakian@ArvinMeritor.com
OnTrac Technical Manager – Troy, MI
Ph 248.273.4641 Fax 248-435-5580



Availability of Replacement Parts and Service Instructions

Replacement parts are currently available and if needed will be provided by ArvinMeritor at no cost. Vehicle manufacturers' (OEM) or repair facilities should obtain replacement parts by contacting ArvinMeritor's OnTrac Performance Plus Call Center using any of the below methods.

Contact: OnTrac Performance Plus Call Center, follow the menu system for the appropriate language and select option number 5

Phone: 1-866-668-7221

Fax: 248-435-5580

Email: ontrac@ArvinMeritor.com

Parts, Labor and Handling Allowance

The following are the details of allowances relating to parts, labor and handling available to vehicle manufacturers' (OEM):

- ArvinMeritor will reimburse at the standard repair time (SRT) of 1 hour for vehicle inspection and will reimburse up to 1 hour per axle seat requiring weld repair.

Claims for Credit

ArvinMeritor will accept warranty claims for inspecting and replacing the suspect studs associated with this notice directly from the vehicle manufacturers (OEM). In order to receive proper credit, such warranty claims must contain the following information at the time of submission:

- Reference to ArvinMeritor Campaign ID Number C10AB
- Reference to NHTSA Campaign ID Number : 10E-047
- Reference to the vehicle manufacturer's campaign number (optional)
- 17-digit vehicle identification number (VIN)
- Axle model and serial number
- Vehicle owner's name, address, and telephone number
- Vehicle in-service date
- Vehicle repair date
- Vehicle mileage at the time of repair (if available)
- Repair facility work order number
- Repairing facility name, address, and telephone number
- Total labor hours required performing the work, not to exceed agreed amount
- Repair facilities hourly rate
- If weld is missing, include axle seat location (e.g. Left Front, Right Rear)

Failure to provide complete information will delay processing of the claim.



Questions relating to warranty claims, replacement parts delivery and parts disposition can be addressed to the ArvinMeritor OnTrac Performance Plus Call Center using any of the below methods.

Contact: OnTrac Performance Plus Call Center, follow the menu system for the appropriate language and select option number 5

Phone: 1-866-668-7221

Fax: 248-435-5580

Email: ontrac@ArvinMeritor.com

Communication

If you conclude that ArvinMeritor has not enabled you to remedy this condition in a reasonable time, you may submit a complaint to the:

Administrator
National Highway Traffic Safety Administration
1200 New Jersey, S.E.
Washington, D.C. 20590

- or -

Call the toll free Vehicle Safety Hotline: 1-888-327-4236; (TTY: 800-424-9153
or go to <http://www.safercar.gov>

We regret any inconvenience that this situation may cause. ArvinMeritor wants to assure you that we are concerned for customer safety and your continued satisfaction with our products.

Sincerely,

ArvinMeritor

Jeremy Tertzakian
OnTrac Technical Manager

Attachments:

CUSTOMER	Order#	Ship Date	ARM Item	Serial Number
VANGUARD NATIONAL TRAILER CORPORATIO	193404	2010/06/15	MPA40S65TP1323	FRK00818589
VANGUARD NATIONAL TRAILER CORPORATIO	193404	2010/06/15	MPA40S65TP1323	FRK00818590
VANGUARD NATIONAL TRAILER CORPORATIO	193404	2010/06/15	MPA40S65TP1323	FRK00818591
VANGUARD NATIONAL TRAILER CORPORATIO	193404	2010/06/15	MPA40S65TP1323	FRK00818592
VANGUARD NATIONAL TRAILER CORPORATIO	193404	2010/06/15	MPA40S65TP1323	FRK00818593
VANGUARD NATIONAL TRAILER CORPORATIO	193404	2010/06/15	MPA40S65TP1323	FRK00818594
VANGUARD NATIONAL TRAILER CORPORATIO	193404	2010/06/15	MPA40S65TP1323	FRK00818595
VANGUARD NATIONAL TRAILER CORPORATIO	193404	2010/06/15	MPA40S65TP1323	FRK00818596
VANGUARD NATIONAL TRAILER CORPORATIO	193404	2010/06/15	MPA40S65TP1323	FRK00818597
VANGUARD NATIONAL TRAILER CORPORATIO	193404	2010/06/15	MPA40S65TP1323	FRK00818598
VANGUARD NATIONAL TRAILER CORPORATIO	193404	2010/06/15	MPA40S65TP1323	FRK00818599
VANGUARD NATIONAL TRAILER CORPORATIO	193404	2010/06/15	MPA40S65TP1323	FRK00818600
VANGUARD NATIONAL TRAILER CORPORATIO	193404	2010/06/15	MPA40S65TP1323	FRK00818601
VANGUARD NATIONAL TRAILER CORPORATIO	193404	2010/06/15	MPA40S65TP1323	FRK00818602
VANGUARD NATIONAL TRAILER CORPORATIO	193404	2010/06/15	MPA40S65TP1323	FRK00818603
VANGUARD NATIONAL TRAILER CORPORATIO	193404	2010/06/22	MPA40S65TP1323	FRK00823739
VANGUARD NATIONAL TRAILER CORPORATIO	193404	2010/06/22	MPA40S65TP1323	FRK00823740
VANGUARD NATIONAL TRAILER CORPORATIO	193404	2010/06/22	MPA40S65TP1323	FRK00823741
VANGUARD NATIONAL TRAILER CORPORATIO	193404	2010/06/22	MPA40S65TP1323	FRK00823742
VANGUARD NATIONAL TRAILER CORPORATIO	193404	2010/06/22	MPA40S65TP1323	FRK00823743
VANGUARD NATIONAL TRAILER CORPORATIO	193404	2010/06/22	MPA40S65TP1323	FRK00823744
VANGUARD NATIONAL TRAILER CORPORATIO	193404	2010/06/22	MPA40S65TP1323	FRK00823745
VANGUARD NATIONAL TRAILER CORPORATIO	193404	2010/06/22	MPA40S65TP1323	FRK00823746
VANGUARD NATIONAL TRAILER CORPORATIO	193404	2010/06/22	MPA40S65TP1323	FRK00823747
VANGUARD NATIONAL TRAILER CORPORATIO	193404	2010/06/22	MPA40S65TP1323	FRK00823748
VANGUARD NATIONAL TRAILER CORPORATIO	193404	2010/06/22	MPA40S65TP1323	FRK00823749
VANGUARD NATIONAL TRAILER CORPORATIO	193404	2010/06/22	MPA40S65TP1323	FRK00823750
VANGUARD NATIONAL TRAILER CORPORATIO	193404	2010/06/22	MPA40S65TP1323	FRK00823751
VANGUARD NATIONAL TRAILER CORPORATIO	193404	2010/06/22	MPA40S65TP1323	FRK00823752
VANGUARD NATIONAL TRAILER CORPORATIO	193404	2010/06/22	MPA40S65TP1323	FRK00823753