

RECALL BULLETIN:
101105FRV

YEAR(S) AFFECTED:
2011

PRODUCT(S) AFFECTED:

Terra, built 6/24/2010 through 10/4/2010

MODEL(S) AFFECTED:
31TS, 34DS

SUBJECT:
Inspection/Correction of high-beam and low-beam headlights

KEYWORDS:
Headlights, lights, bulbs, high beam, low beam

ISSUE DATE:
December 2010

The purpose of this Bulletin is to inform all Fleetwood dealers about the need to inspect, and if necessary, replace headlights on certain 2011 Terra motor homes. A list of affected motor home serial numbers appears on the last page of this Bulletin.

CONDITION:

The 2011 Terra motor homes affected by this recall were built with the high-beam and low-beam headlights in the incorrect locations, as specified by the standards of FMVSS108.

According to the pertinent language of FMVSS108, the lower beam should be provided by the “outboard light source (or the uppermost if arranged vertically)”, and the upper beam should be provided by “the inboard light source (or the lower one if arranged vertically)”. An example of incorrect headlights is shown in Figure 1 and an example of correct headlights is shown in Figure 2.

INSPECTION:

Follow the steps below to inspect, and if necessary, replace the headlights, as well as the wire harnesses connected between the headlights and the chassis harness.

1. Park the motor home and examine the headlights. The low-beam headlight should be located in the higher, outboard position (as shown in Figure 2). The high-beam headlight should be located in the lower position, nearer the center of the cap. An example of a low-beam headlight is shown in Figure 3, and an example of a high-beam headlight is shown in Figure 4.



Figure 1 - INCORRECT Headlights



Figure 2 - Correct Headlights



Figure 3 - Low-Beam Headlight



Figure 4 - High-Beam Headlight

If the headlights are not located in the positions described above, proceed to the CORRECTION, Step 2.

© 2010 Fleetwood RV, Inc.

This bulletin is supplied for technical information only and is not an authorization for repairs.

Federal law (section 154 of the national traffic and motor vehicle safety act of 1966) requires that: If you have received a notice of recall or failure to comply from Fleetwood or any component Manufacturer, you must repair or otherwise correct the defects on vehicles remaining in your inventory, according to the notification, before selling or leasing the vehicles. Any vehicle lessor receiving this recall notice must forward a copy of the notice to the lessee within ten days.

"It is impossible to know, evaluate and advise the service trade of all conceivable ways in which service might be done or of the possible hazardous consequences of each way. Accordingly, anyone who uses a service procedure or tool must first assure that neither personal safety nor vehicle safety will be jeopardized by the selected service methods."

- Turn off the ignition and remove the ignition key. Maintain control of the keys until all work is completed.



WARNING

- REMOVE ALL JEWELRY BEFORE WORKING ON OR NEAR BATTERIES.**
- BATTERIES CONTAIN ACID AND EXPLOSIVE GASES; USE EXTREME CARE WHEN WORKING NEAR BATTERIES. DO NOT SMOKE OR HAVE OPEN FLAMES. AVOID CREATING SPARKS AROUND WET CELL BATTERIES.**

- Label and then remove the battery cables from the Main chassis battery, located on the front of the bulkhead, and the Auxiliary batteries, located under the entry step. Remove the battery negative cable first, and then remove the positive cable.
- Open the engine compartment door to access the headlights. **VERIFY** there is no power to the headlights. Cut the wires for each headlight where the chassis wire harness connects to the headlight wire harness. Label the chassis wire harness connections (e.g., "HI" and "LO") if no labels are present.
- Locate the two brackets securing the headlights to the studs inside of the lower front cap. (See Figures 5 and 6.) Use an inspection mirror if necessary to locate and remove the fastening hardware for the brackets, then remove the brackets using a driver with socket bit, or a ratchet. Retain brackets and fastening hardware for reassembly.

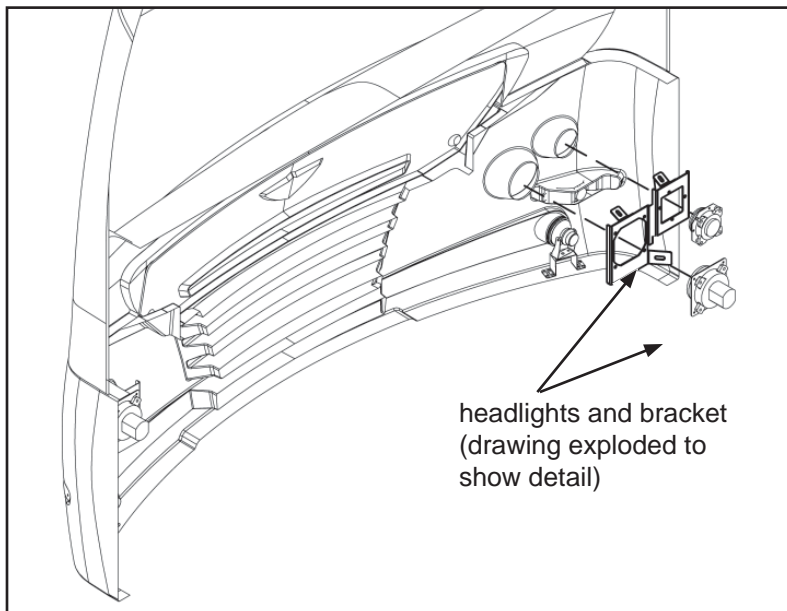

Figure 5 - View shown from inside of lower front cap

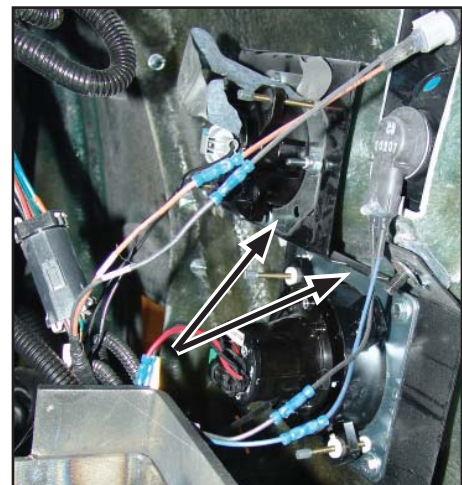

Figure 6 - Headlights and bracket assembled inside of front cap

This bulletin is supplied for technical information only and is not an authorization for repairs.

Federal law (section 154 of the national traffic and motor vehicle safety act of 1966) requires that: If you have received a notice of recall or failure to comply from Fleetwood or any component Manufacturer, you must repair or otherwise correct the defects on vehicles remaining in your inventory, according to the notification, before selling or leasing the vehicles. Any vehicle lessor receiving this recall notice must forward a copy of the notice to the lessee within ten days.

"It is impossible to know, evaluate and advise the service trade of all conceivable ways in which service might be done or of the possible hazardous consequences of each way. Accordingly, anyone who uses a service procedure or tool must first assure that neither personal safety nor vehicle safety will be jeopardized by the selected service methods."

STEPS 6-8 MAY BE PERFORMED AT A WORKBENCH

6. Remove the fasteners for the headlights from one of the brackets, noting stacking order of the hardware. Retain the original fasteners and mounting bracket for assembly of the new headlights. Discard the original high-beam and low-beam headlights.
7. Fasten a new high-beam and low-beam headlight, included with the Recall Kit, into the original mounting bracket, using the hardware retained in Step 6. Torque nuts to 50-55 inch-lbs.
8. Plug the headlight wire harnesses (included with each new headlight) into the back of the new lights.
9. Position the headlight assembly inside the lower front cap and reinstall the bracket onto the studs in the cap using original fastening hardware. Torque nuts to 40-45 inch-lbs.
10. Strip approx. 3/16" of the jacket insulation from the ends of the new headlight harness wires and from ends of the headlight wires on the chassis wire harness. Slide a piece of heat-shrink tubing over each of the headlight harness wires. Use insulated butt connectors to connect the new headlight wire harness to the chassis wire harness. Center the heat shrink tubing over each new connection. Use a heat gun to seal the tubing into place. Wrap each new connection at least four times with electrical tape. Verify all connections are secure and water-proof. Cover the connections with wire loom.



	<u>Headlight Harness</u>	to	<u>CHASSIS HARNESS</u>
Low-beam connection:	Black	to	BLACK
	Black	to	TAN
High-beam connection:	Red	to	GREEN
	Black	to	BLACK

11. Repeat Steps 6-10 for the remaining set of headlights.
12. Reconnect the battery wires after completing all electrical work.
13. Test headlight operation; correct if necessary.
14. Verify headlights are properly aimed and adjusted to ensure alignment and compliance with possible local, state, federal and provincial codes.
15. Close the engine compartment after completing repairs.

This bulletin is supplied for technical information only and is not an authorization for repairs.

Federal law (section 154 of the national traffic and motor vehicle safety act of 1966) requires that: If you have received a notice of recall or failure to comply from Fleetwood or any component Manufacturer, you must repair or otherwise correct the defects on vehicles remaining in your inventory, according to the notification, before selling or leasing the vehicles. Any vehicle lessor receiving this recall notice must forward a copy of the notice to the lessee within ten days.

"It is impossible to know, evaluate and advise the service trade of all conceivable ways in which service might be done or of the possible hazardous consequences of each way. Accordingly, anyone who uses a service procedure or tool must first assure that neither personal safety nor vehicle safety will be jeopardized by the selected service methods."

PARTS:

<u>Part Number</u>	<u>Description</u>	<u>Qty.</u>
#586691	Kit, Recall 101105FRV, Terra Headlights	1
	Kit Contains:	
	Headlight, High-Beam (qty. 2)	
	Headlight, Low-Beam (qty. 2)	
Obtain Locally	Insulated Butt Connectors	8
Obtain Locally	Electrical Tape	As Required
Obtain Locally	Heat Shrink Tubing	As Required
Obtain Locally	Wire loom (approx. 6" per connection)	As Required

TOOLS:

Inspection mirror
Power driver with 1/2" and 7/16" socket bits
Socket with ratchet
7/16" open end wrench
Wire cutters
Wire strippers
Wire crimpers
Utility knife

WARRANTY LABOR ALLOWANCE:

Recall 101105FRV, 2011 Terra Headlights

Flat Rate Code:

6005-12 1.50 Hrs. Inspected/Defective/Repaired

*If you have any questions concerning this Bulletin, contact
Fleetwood RV Dealer Technical Support at:
1-800-816-9825*

*Fleetwood Service Literature is available at:
www.fleetwoodrvdealers.com*

This bulletin is supplied for technical information only and is not an authorization for repairs.

Federal law (section 154 of the national traffic and motor vehicle safety act of 1966) requires that: If you have received a notice of recall or failure to comply from Fleetwood or any component Manufacturer, you must repair or otherwise correct the defects on vehicles remaining in your inventory, according to the notification, before selling or leasing the vehicles. Any vehicle lessor receiving this recall notice must forward a copy of the notice to the lessee within ten days.

"It is impossible to know, evaluate and advise the service trade of all conceivable ways in which service might be done or of the possible hazardous consequences of each way. Accordingly, anyone who uses a service procedure or tool must first assure that neither personal safety nor vehicle safety will be jeopardized by the selected service methods."

Recall 101105FRV Affected Unit Serial Numbers

2011 Terra

783TB4407086
783TB4407077
783TB4406928
783TB4406927
783TB4406918
783TB4406917
783TB4406916
783TB4406905
783TB4406904
783TB4406834
783TB4406749
783TB4406731
783TB4406671
783TB4406670
783TB4406669
783TB4406655
783TB4406654
783TB4406653
783TB4406615
783TB4406614
783TB4406609
783TB4406608
783TB4406521
783TB4406520
783TB4406519
783TB4406513
783TB4406512
783TB4406442

783TB4406441
783TB4406325
783TB4406324
783TB4406323
783TB4406322
783TB4406321
783TB4406013
783TB4405908
783DB4407065
783DB4406924
783DB4406923
783DB4406911
783DB4406910
783DB4406909
783DB4406899
783DB4406898
783DB4406897
783DB4406844
783DB4406843
783DB4406842
783DB4406748
783DB4406747
783DB4406739
783DB4406738
783DB4406648
783DB4406647
783DB4406602
783DB4406601

783DB4406420
783DB4406419
783DB4406314
783DB4406313
783DB4406312
783DB4406311
783DB4406175
783DB4406174
783DB4406173
783DB4406168
783DB4406167
783DB4406166
783DB4406165
783DB4406160
783DB4406159
783DB4406158
783DB4406157
783DB4406152
783DB4406151
783DB4406150
783DB4406149
783DB4406102
783DB4406101
783DB4406100
783DB4406099
783DB4406098
783DB4405984
783DB4405800

This bulletin is supplied for technical information only and is not an authorization for repairs.

Federal law (section 154 of the national traffic and motor vehicle safety act of 1966) requires that: If you have received a notice of recall or failure to comply from Fleetwood or any component Manufacturer, you must repair or otherwise correct the defects on vehicles remaining in your inventory, according to the notification, before selling or leasing the vehicles. Any vehicle lessor receiving this recall notice must forward a copy of the notice to the lessee within ten days.

"It is impossible to know, evaluate and advise the service trade of all conceivable ways in which service might be done or of the possible hazardous consequences of each way. Accordingly, anyone who uses a service procedure or tool must first assure that neither personal safety nor vehicle safety will be jeopardized by the selected service methods."