



CHRYSLER

December 2010

Dealer Service Instructions for:

Safety Recall K27

Certification and Tire Pressure Labels

Models

- 2011 (DS) Ram 1500 Series Pick Up Truck
- 2011 (DJ) Ram 2500 Series Pick Up Truck
- 2011 (D2) Ram 3500 Series Pick Up Truck

NOTE: This recall applies only to the above vehicles built at:

- *Warren Truck Assembly Plant ("S" in the 11th VIN Position) built through August 10, 2010 (MDH 081016).*
- *Saltillo Truck Assembly Plant ("G" in the 11th VIN Position) built through August 05, 2010 (MDH 080513).*

IMPORTANT: Many of the vehicles within the above build period have already been inspected or repaired and, therefore, have been excluded from this recall.

IMPORTANT: Some of the involved vehicles may be in dealer new vehicle inventory. Federal law requires you to complete this recall service on these vehicles before retail delivery. Dealers should also consider this requirement to apply to used vehicle inventory and should perform this recall on vehicles in for service. Involved vehicles can be determined by using the VIP inquiry process.

Subject

The Certification label and Supplemental Tire Pressure Information label on about 770 of the above vehicles fail to conform to the requirements of Federal Motor Vehicle Safety Standard (FMVSS) No. 120, "Tire Selection and Rims for Motor Vehicles Other than Passenger Cars". The labels contain incorrect vehicle weight rating and seat capacity information. This can cause improper loading of the vehicle and result in a crash without warning.

Repair

Dealers are required to apply a new Certification label and Supplemental Tire Pressure Information label onto all involved vehicles in new vehicle inventory.

A Certification label and Supplemental Tire Pressure Information label will be mailed to owners known to Chrysler for the owners to install (or for installation by their dealer if preferred).

Parts Information

New Certification labels and Supplemental Tire Pressure Information labels are being mailed to all owners known to Chrysler. Since all labels are VIN specific, no part numbers are available to order replacement labels.

If an owner's label is lost or damaged, dealers may request replacement label(s) by contacting the Chrysler Group LLC Customer Call Center (1-800-726-4636).

New Certification labels and Supplemental Tire Pressure Information labels are also being mailed to the Service Manager for vehicles in dealer inventory. Dealers are to install labels onto all involved vehicles in new vehicle inventory.

If the vehicle is no longer in the ship to dealer inventory, the label(s) **must be sent back** to Chrysler at the following address:

Chrysler Group LLC
800 Chrysler Drive
Auburn Hills, MI
CIMS 482-00-91
48326-2757

Service Procedure

1. Open the driver's door and locate the Certification label on the driver's door as shown in Figure 1.
2. Clean the existing Certification label with alcohol / glass cleaner or equivalent and a soft cloth to remove any dirt, oil residue or grease.
3. Remove the Certification label from its paper backing and carefully install it over the existing Certification label (Figure 1). Firmly press and smooth the label to the surface of the existing Certification label to ensure good adhesion.

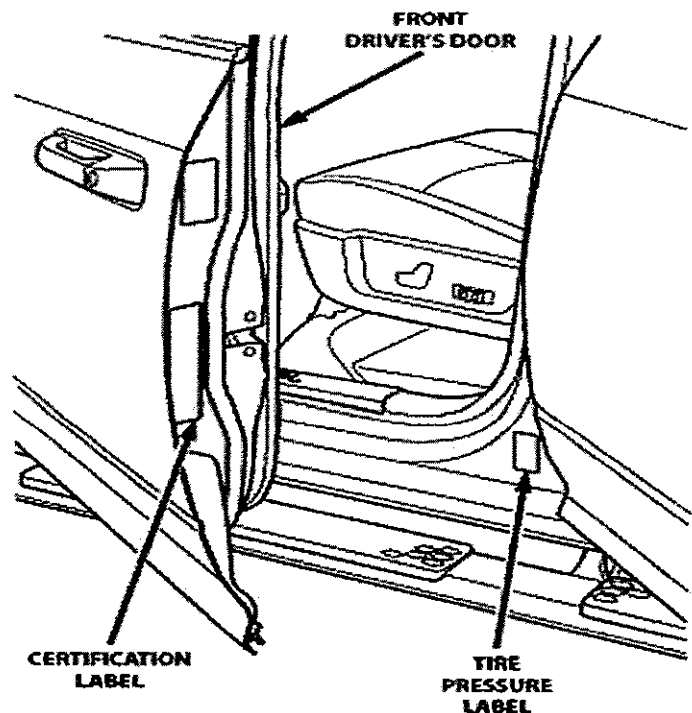
**Figure 1 – Four Door Model Shown**

4. Locate the Supplemental Tire Pressure Information label on the driver side lower B-post as shown in Figure 1.
5. Clean the existing Supplemental Tire Pressure Information label with alcohol / glass cleaner or equivalent and a soft cloth to remove any dirt, oil residue or grease.
6. Remove the Supplemental Tire Pressure Information label from its paper backing and carefully install it over the existing label (Figure 1). Firmly press and smooth the label to the surface of the existing Supplemental Tire Pressure Information label to ensure good adhesion.

Completion Reporting and Reimbursement

Claims for vehicles that have been serviced must be submitted on the DealerCONNECT Claim Entry Screen located on the Service tab. Claims submitted will be used by Chrysler to record recall service completions and provide dealer payments.

Use the following labor operation number and time allowance:

	Labor Operation Number	Time Allowance
Install Certification label and Supplemental Tire Pressure Information label	23-K2-71-82	0.2 hours

NOTE: See the Warranty Administration Manual, Recall Claim Processing Section, for complete recall claim processing instructions.

Dealer Notification

To view this notification on DealerCONNECT, select “Global Recall System” on the Service tab, then click on the description of this notification.

Owner Notification and Service Scheduling

All involved vehicle owners known to Chrysler are being notified of the service requirement by first class mail. They are requested to install the supplied labels over the original labels on their vehicle. Any owner who prefers not to install the label is asked to schedule an appointment for the service with their dealer. A generic copy of the owner letter is attached.

Enclosed with each owner letter is an Owner Notification postcard to allow owners to update our records if applicable.

Vehicle Lists, Global Recall System, VIP and Dealer Follow Up

All involved vehicles have been entered into the DealerCONNECT Global Recall System (GRS) and Vehicle Information Plus (VIP) for dealer inquiry as needed.

GRS provides involved dealers with an updated VIN list of their incomplete vehicles. The owner's name, address and phone number are listed if known. Completed vehicles are removed from GRS within several days of repair claim submission.

To use this system, click on the “**Service**” tab and then click on “**Global Recall System.**” Your dealer's VIN list for each recall displayed can be sorted by: those vehicles that were unsold at recall launch, those with a phone number, city, zip code, or VIN sequence.

Dealers must perform this repair on all unsold vehicles before retail delivery. Dealers should also use the VIN list to follow up with all owners to schedule appointments for this repair.

Recall VIN lists may contain confidential, restricted owner name and address information that was obtained from the Department of Motor Vehicles of various states. Use of this information is permitted for this recall only and is strictly prohibited from all other use.

Additional Information

If you have any questions or need assistance in completing this action, please contact your Service and Parts District Manager.

Customer Services Field Operations
Chrysler Group LLC