

CERTAIN 1998-2003 MODEL YEAR WINDSTAR VEHICLES OPERATED IN CORROSION STATES – REAR AXLE INSPECTION AND REPAIR

OVERVIEW

In some of the affected vehicles, the rear axle could potentially fracture when operated in high corrosion areas (where salt is used on the roadways during winter months) for an extended period of time. If the rear axle should fracture, vehicle handling may be affected which could increase the risk of a crash.

Dealers are to clean and inspect the rear axle for cracks. If the rear axle passes the inspection, return the vehicle to the owner along with the “Passed Rear Axle Inspection – No Crack” Customer Information Sheet attached. If the rear axle did not pass the inspection, contact the Special Service Support Center (SSSC) at 1-800-325-5621 for further instructions.

IMPORTANT NOTES:

- Parts are not currently available for this recall.
- Vehicles that pass inspection will be returned to the owners until parts are available to reinforce the axle. Ford will advise owners via U.S. mail when parts are available.
- For vehicles that do not pass the inspection, the SSSC will authorize either the replacement of the axle or a rental vehicle based on axle availability and customer rental needs.
- Rental vehicles will be claimed under a separate program (79M01) using an approval code provided by the SSSC.
- This bulletin will be supplemented with parts ordering information and service procedures when parts become available.
- Performing (and claiming) the inspection will **NOT** “close-out” Safety Recall 10S13.

Rear Axle Cleaning and Inspection Page 2

Rear Axle Replacement Page 4

Removal Page 4

Installation Page 9



REAR AXLE CLEANING AND INSPECTION

1. With the gear selector in NEUTRAL, position the vehicle on a hoist and lift the vehicle. For additional information, refer to the WSM, Section 100-02.
2. Measure and mark the inspection areas located 127 mm (5 in) to 229 mm (9 in) inboard of the axle welds. See Figure 1.

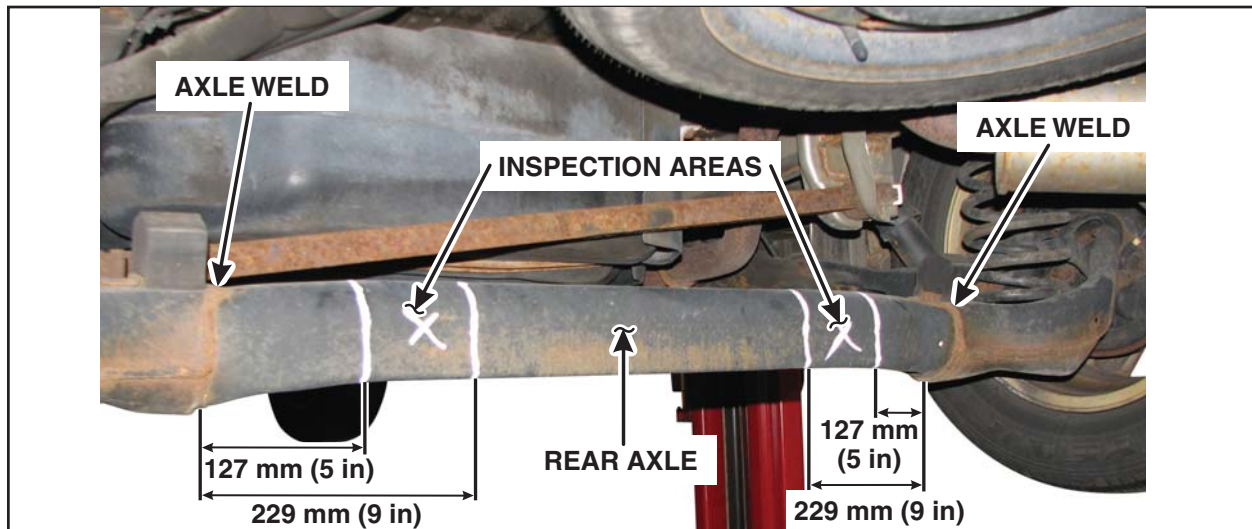

FIGURE 1

3. **NOTE:** It is very important to clean the front, rear and inside surfaces of the rear axle inspection areas to expose bare metal without reducing metal thickness.

Using a knot wire cup brush approximately 25 mm (1 in) in diameter, clean the rear axle. See Figure 2.

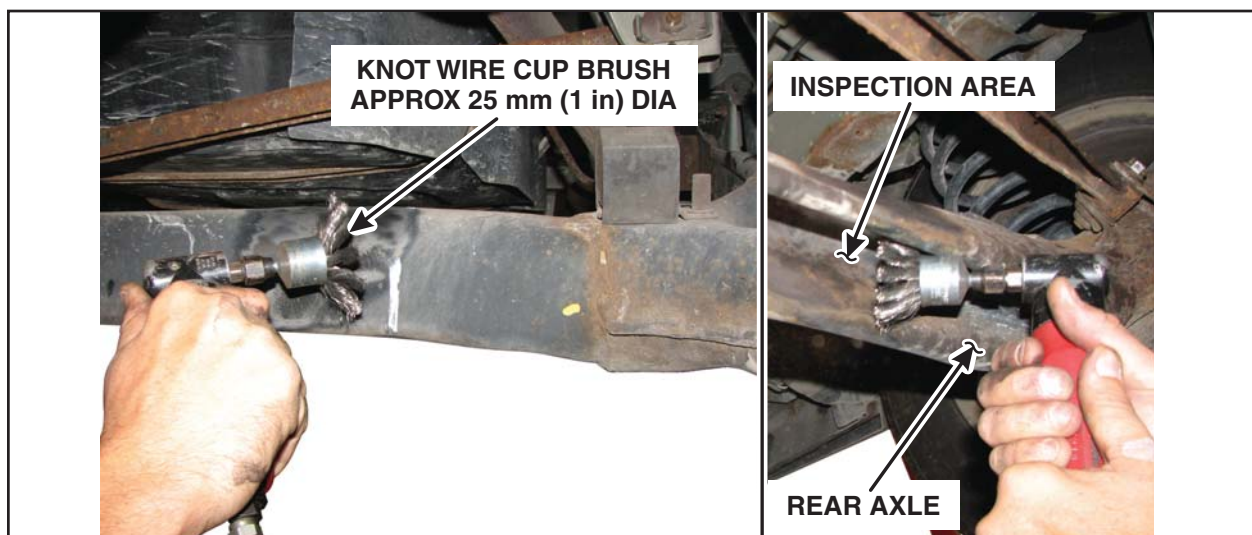

FIGURE 2



4. Visually inspect the cleaned front, rear and inside areas of the axle for cracks. See Figure 3.

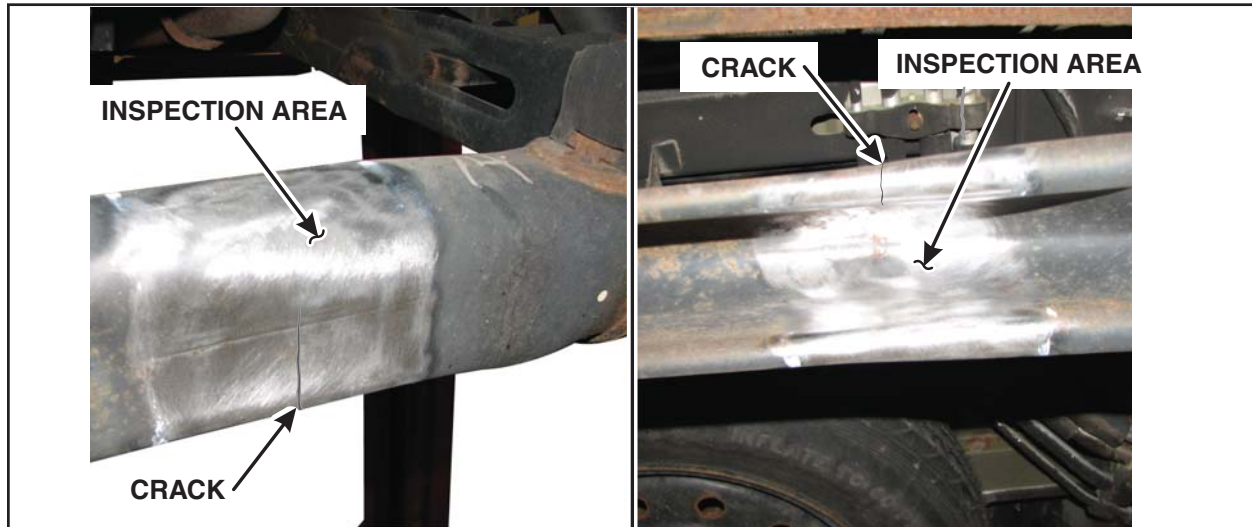

FIGURE 3

5. Rear axle inspection results:

- a. If the rear axle is not cracked, apply PM-13-A Anti-Corrosion Coating to the inspection areas. See Figure 4. Proceed to step 6.
- b. If the rear axle has a crack, have the service manager contact the Special Service Support Center at 1-800-325-5621 for further instructions.

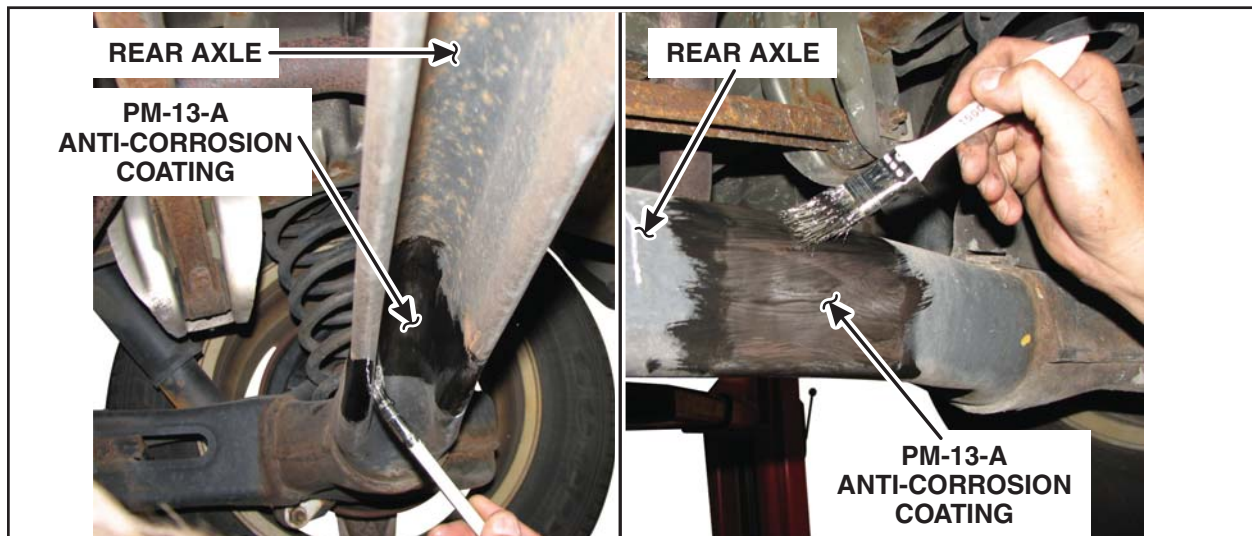

FIGURE 4

6. Lower the vehicle.



REAR AXLE REPLACEMENT

Removal

NOTICE: Suspension fasteners affect performance of vital components and systems. The failure of suspension fasteners can result in major service expense. If replacement is necessary, they must be replaced with the same part number, or an equivalent part. Do not use a replacement part of lesser quality or substitute design. Torque values must be used as specified during reassembly to ensure proper retention of these parts.

NOTE: The following rear axle replacement procedure is different than the procedure described in the Workshop Manual. The procedure was revised because the emergency brake cable and service brakes do not need to be disconnected in order to remove and replace the rear axle.

1. **NOTE:** To prevent the brake drum from sliding off the hub, reinstall one wheel nut on each hub.

Remove both rear wheel and tire assemblies. For additional information, refer to the WSM, Section 204-04.

2. Remove the parking brake cable bracket nuts and position the parking brake cable brackets aside. See Figure 5.

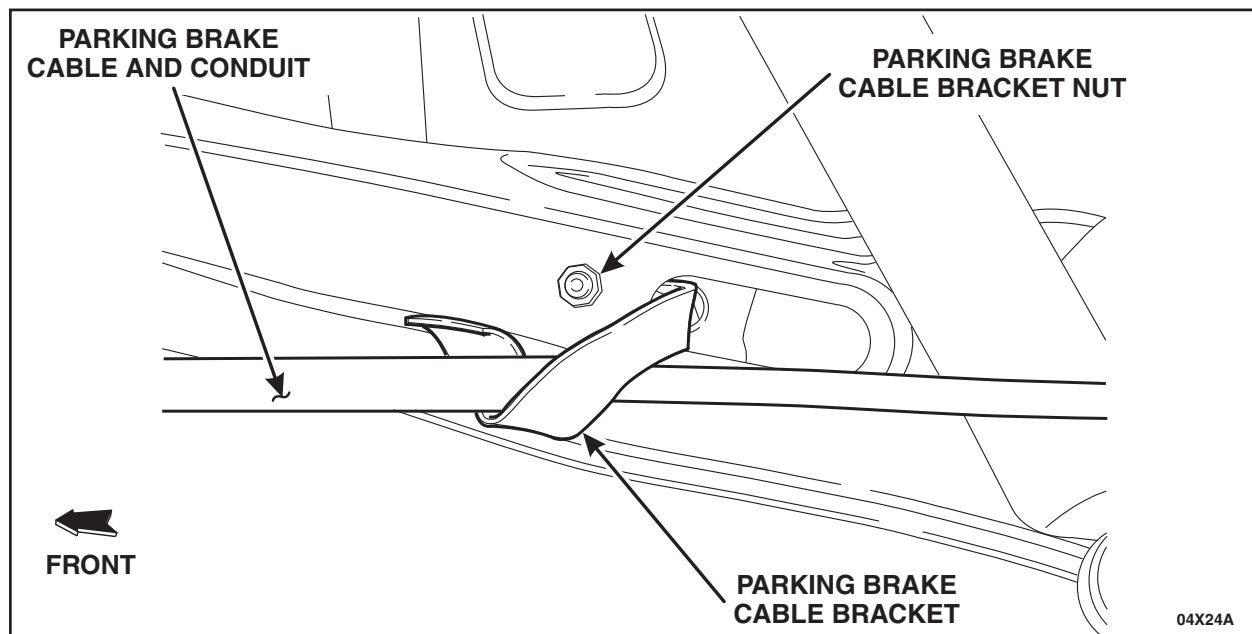

FIGURE 5



3. Secure the rear axle to High Lift Transmission Jack 014-00942 or equivalent.
4. Disconnect the track bar from the rear axle. See Figure 6.
 - Remove the track bar bolt.
 - Remove the track bar from the rear axle track bar mounting bracket.
 - Remove the J-nut from the rear axle track bar mounting bracket. The bolt and J-nut will be reused on the **new** rear axle. If the bolt or J-nut has been damaged, replace as necessary.

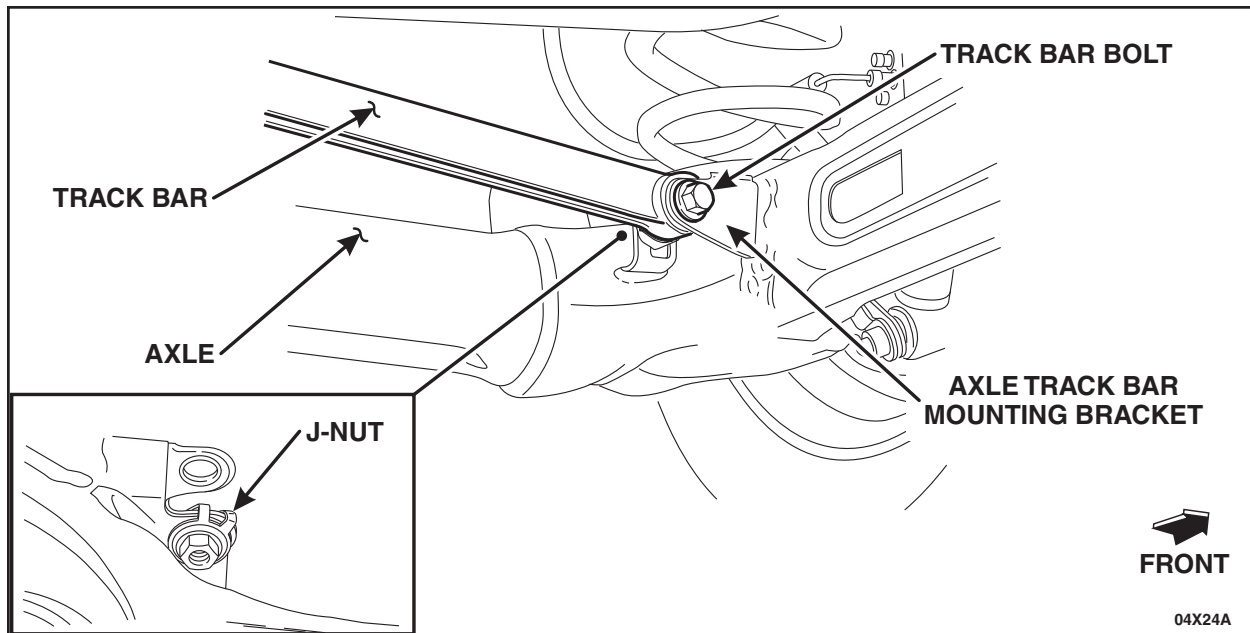

FIGURE 6

5. Remove the shock absorber lower bolts.



6. **NOTE:** The spring insulators may come out with the spring when the spring is removed.

Carefully lower the rear axle assembly enough to remove the rear springs. See Figure 7.

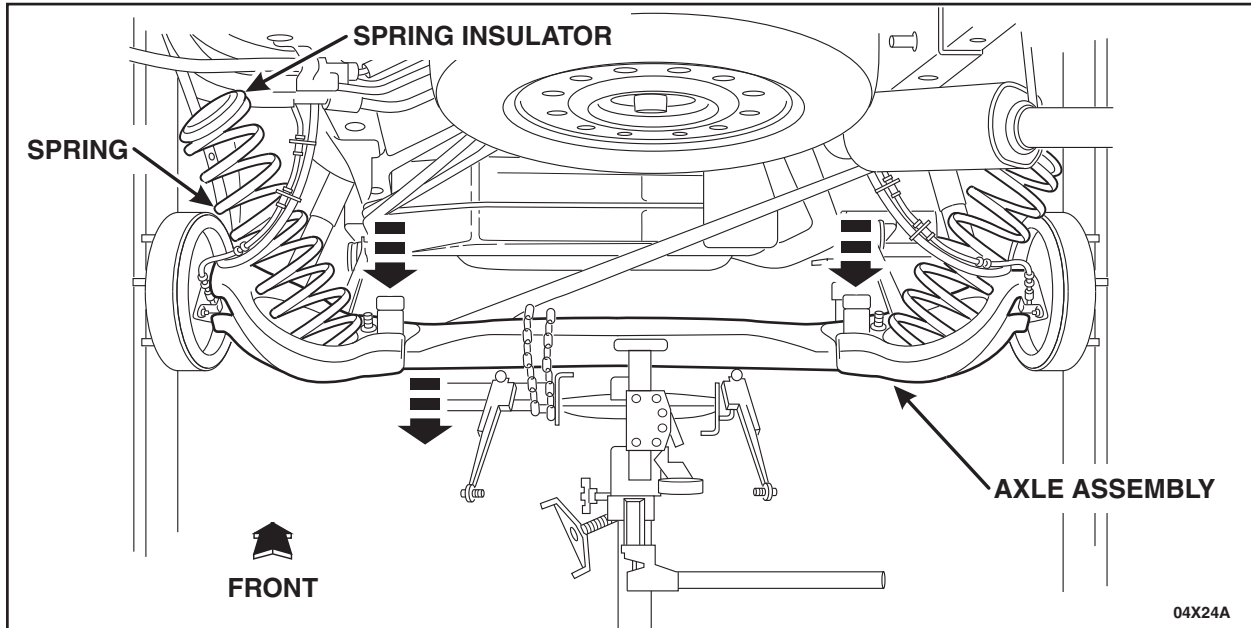

FIGURE 7

7. Remove the four spindle retaining nuts. See Figure 8.

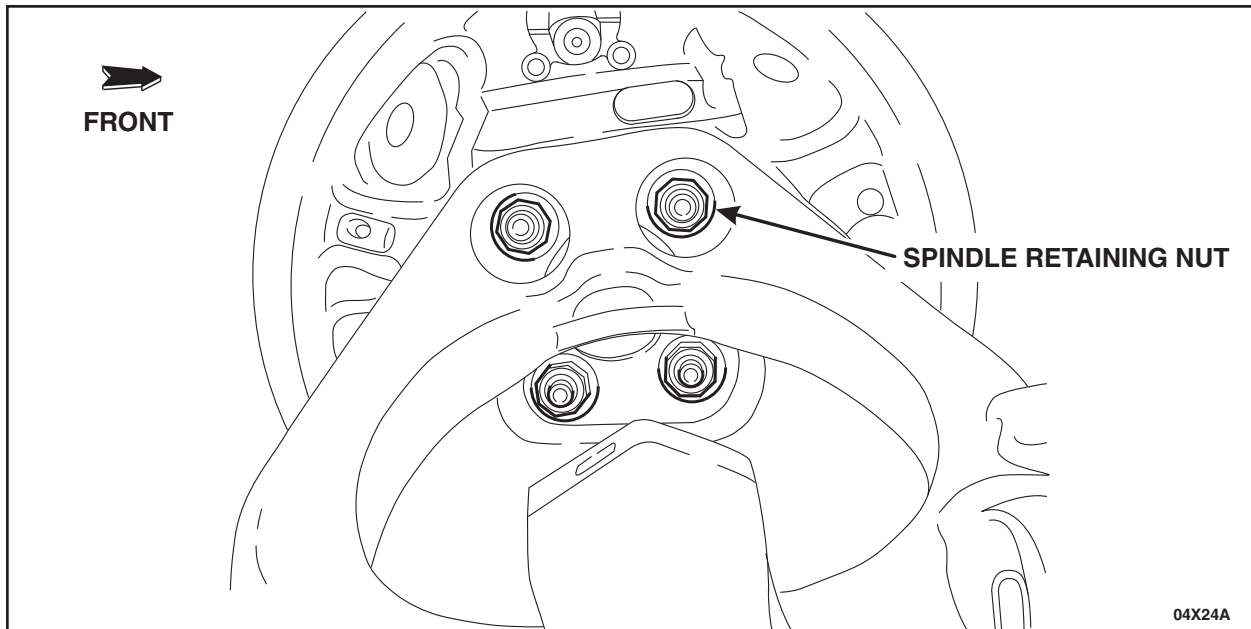

FIGURE 8



8. **NOTICE:** When removing the spindle, hub and brake assembly, never allow it to hang from the brake caliper flexible hose. To prevent damage to the flexible hose, provide suitable support.

Position the spindle, hub and brake assemblies aside. See Figure 9.

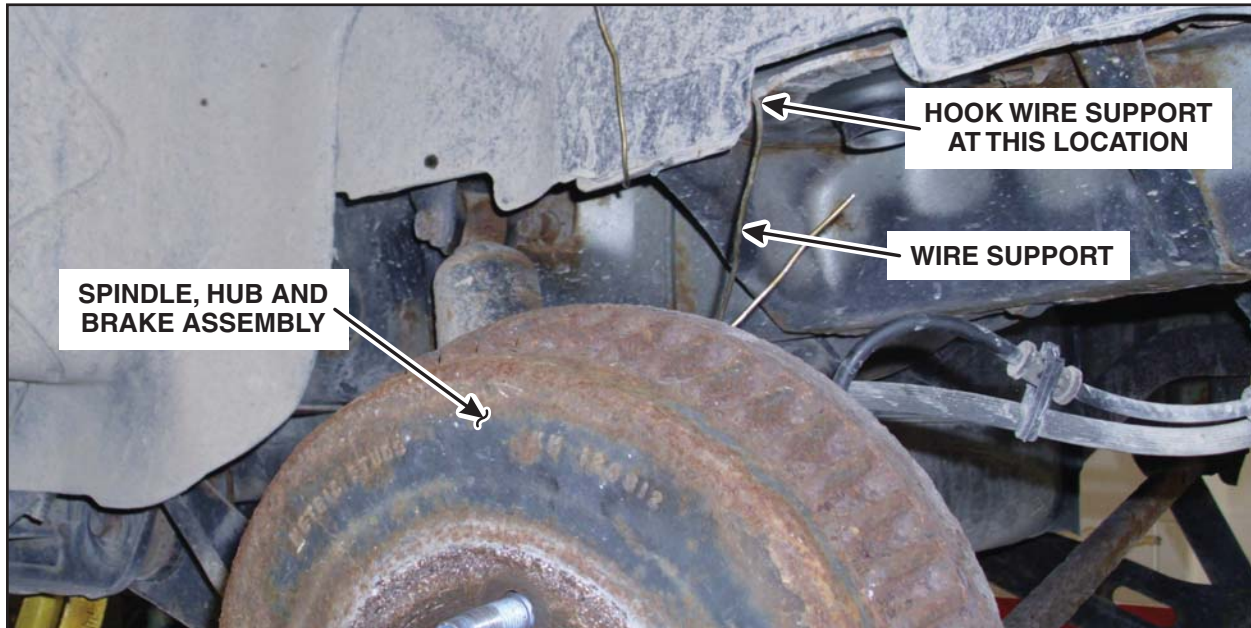

FIGURE 9

9. Remove the trailing arm-to-subframe bolts. See Figure 10.

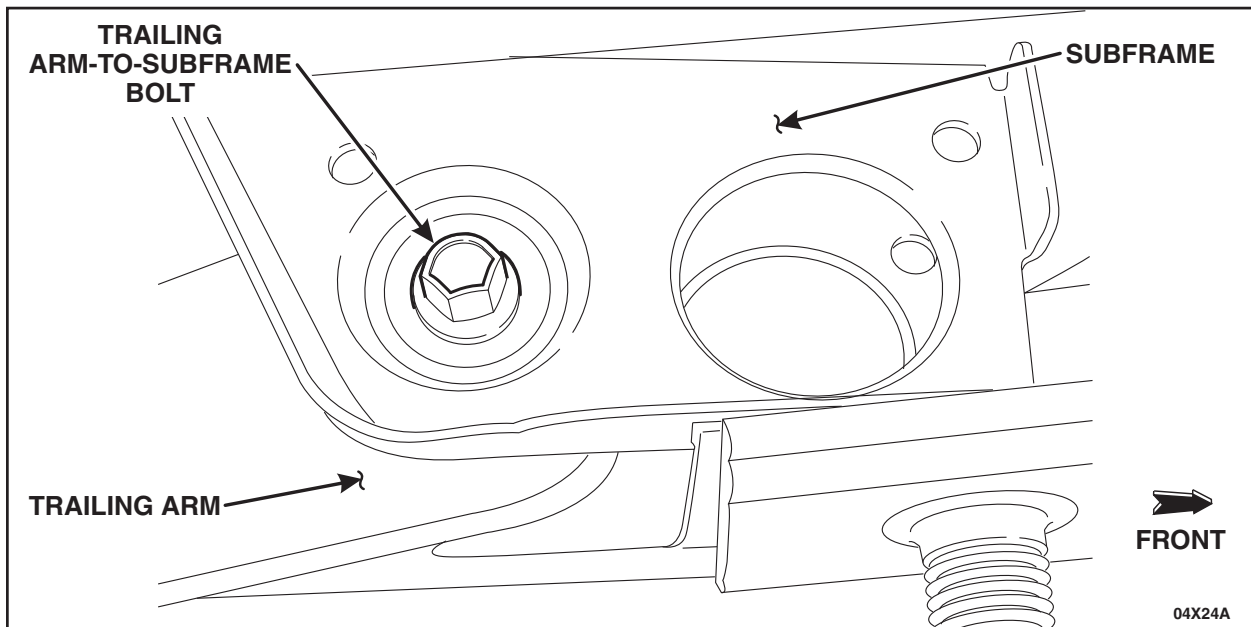

FIGURE 10



10. Carefully lower the rear axle and remove it from the vehicle.

11. **NOTE:** If the spring lower insulators did not come out with the springs, remove the insulators from the rear axle assembly.

Remove the jounce bumper bolts and bumpers, and if necessary, the spring lower insulators. The jounce bumpers and the spring lower insulators will be reused with the **new** rear axle.



Installation

NOTICE: Do not tighten the rear suspension fasteners until the rear axle has been raised and the rear suspension has been loaded. By lifting the rear axle and loading the rear suspension, it will simulate the vehicle's ride height. Failure to follow these instructions may result in incorrect clamp load and bushing damage may occur.

12. Install the jounce bumpers, and if necessary, the spring lower insulators on the **new** rear axle.
 - Tighten to 25 Nm (18 lb-ft).
13. Using a High Lift Transmission Jack 014-00942 or equivalent, raise the rear axle assembly in position and install the trailing arm-to-subframe bolts. See Figure 10.
14. Position the spindle, hub and brake assemblies in place.
15. Install the four spindle retaining nuts. See Figure 8.
 - Tighten to 70 Nm (52 lb-ft).
16. **NOTE:** Make sure the spring upper insulators are positioned correctly on the springs.
Install the springs on the rear axle assembly. Make sure the springs are correctly seated.
17. Raise the rear axle assembly and position the shock absorbers on the rear axle. Install the shock absorber lower bolts.
18. Install the J-nut on the rear axle track bar mounting bracket. Position the track bar on the rear axle track bar mounting bracket and install the track bar bolt. See Figure 6.
19. Load the rear suspension by raising the axle assembly. Once the rear suspension has been loaded, tighten the following components:
 - Tighten the trailing arm-to-subframe bolts to 133 Nm (98 lb-ft).
 - Tighten the shock absorber lower bolts to 80 Nm (59 lb-ft).
 - Tighten the track bar bolt to 80 Nm (59 lb-ft).
20. Remove High Lift Transmission Jack 014-00942 or equivalent.
21. Position the parking brake cable brackets in place and install the parking brake cable bracket nuts. See Figure 5.
 - Tighten to 25 Nm (18 lb-ft).
22. Install both rear wheel and tire assemblies. For additional information, refer to the WSM, Section 204-04.
23. Lower the vehicle.

