



MERCEDES-BENZ USA, LLC  
One Mercedes Drive, P.O. Box 350, Montvale, NJ 07645-0350  
Phone (201) 573-0600  
Fax (201) 573-0117  
MBUSA.com

## newschannel UPDATE

TO: Mercedes-Benz Dealer Principals, General Managers, Sales Managers, Service Managers, Parts Managers

FROM: Thomas Brunner; Department Manager; Vehicle Compliance and Analysis; Engineering Services

DATE: August 4, 2010

RE: **Recall Campaign**– Head Lamp and Front Turn Signal Grills, Model 463, Model Years 2002 - 2010

On August 2, 2010 the National Highway Traffic Safety Administration (NHTSA) was notified that Mercedes-Benz USA, LLC (MBUSA) will conduct a voluntary Recall Campaign on certain Model Year 2002 - 2010 G-Class (463) vehicles with regard to the Headlamp Grills. This notification will be posted on the NHTSA web site and may generate some customer questions.

Daimler AG (DAG) has determined that the headlamps of the affected vehicles are equipped with a protective grill for protection of the headlamps during off-highway operation. Federal Motor Vehicle Safety Standard (FMVSS) 108 S7.8.5 specifies that a grill shall not be installed in front of the lamp. The affected vehicles meet all luminosity requirements of FMVSS 108 with the protective grill installed so there is no consequence to highway safety from the presence of the grill. The affected vehicles are also equipped with an allowable grill cover for front turn signal protection which affects compliance with FMVSS 108.

MBUSA therefore has initiated a recall of all potentially affected vehicles described above. The repair will involve removal of the headlamp grills and replacement of the turn signal reflectors. (The rear tail lamp grills are compliant and do not need to be removed.)

**Given this notice, it is illegal to retail any affected MY new or pre-owned G-Class (463) vehicles in your inventory until the headlamp grills and the front turn signal grills have been removed.**

Dealers with affected new and pre-owned Model 463 vehicles in their inventory can follow the attached work instructions for removal of the headlamp grills and front turn signal grills. Arriving today, affected Dealers will receive parts to plug the screw anchor holes in the fenders. Additional parts may be ordered from your facing PDC. Removed headlamp grills are to be removed and returned to the QEC. Removed front turn signal grills and brackets, etc. are to be put into a plastic bag and placed in the storage compartment under the right rear seat of the vehicle. The front turn signal grills will be reinstalled once the replacement turn signal reflectors are available with the Recall launch.

**Please print out the Notice, on the following page, and place in the affected vehicles glove box.**

**This Recall Campaign will be launched in approximately November, 2010, due to parts availability, and affects approximately 4,020 vehicles in the U.S.**

Owner notification will to be sent approximately one week after recall launch.

While we regret any inconvenience this causes, MBUSA is determined to maintain a high level of vehicle quality and customer satisfaction.

Please refer all customer inquiries to the Customer Assistance Center at 1-800-FOR-MERCEdes (1-800-367-6372).





Mercedes-Benz

Mercedes-Benz USA, LLC  
A Daimler Company

**NOTICE:**

**Dear Customer,**

**The factory installed front fender turn signal grills on this vehicle do not meet our specifications and have been removed. The turn signal grills as installed emitted a light from the turn signals that may not meet Federal Motor Vehicle Safety Standard performance specifications.**

**You will receive a Safety Recall letter from MBUSA when optimized turn signal reflectors, providing additional light output, are available for installation free of charge on your vehicle. When these optimized turn signal reflectors are installed on your vehicle, the turn signal grills will be re-installed.**

**We apologize for any inconvenience this situation may cause.**

**Sincerely,**

**Mercedes-Benz USA**

**(Dealer: Please place this notice in Glove box.)**



## Remove Directional Grill and Headlamp Grill

### Procedure

#### A. Remove Directional Grill and Intall Body Plugs



**Figure 1**

1. Open directional grill (A, Figure 1).
2. Remove torx screw (B, Figure 1) from clip (C) and remove clip.
3. Close direction grill (A, Figure 1) then remove two torx screw (arrows).
4. Remove clips (D, Figure 1) and remove grill (A).

**Note:**

Do not discard removed parts.



**Figure 2**

5. Install previously removed torx screw (arrow, Figure 2) 2 turns into body anchor (A) using torx screw driver.
- Note:**  
**DO NOT** install torx screw more than 2 turns into body anchor.
6. Pull body anchor (A, Figure 2) out from fender using locking pliers. Repeat steps 5 and 6 for remaining two body anchors.
  7. Install body plugs (arrows, Figure 3) into 3 anchor holes using even pressure.
  8. Repeat procedure on opposite side.



**Figure 3**

9. Place all parts removed in steps 1-6 in a plastic bag (arrow, Figure 2) then store parts in storage compartment under right rear seat (A). Secure parts with strap (B) then lower seat into locked position.

**Note:**

The removed turn signal grills will be re-installed once the recall is launched later this year.



Figure 4

**B. Remove Headlamp Grills**

1. Remove bolt (A, Figure 5) and two screws (arrows) then remove headlamp grill (B) from front brush guard (C). Repeat this step on opposite side.

**Note:**

Return headlamp grills to the QEC.

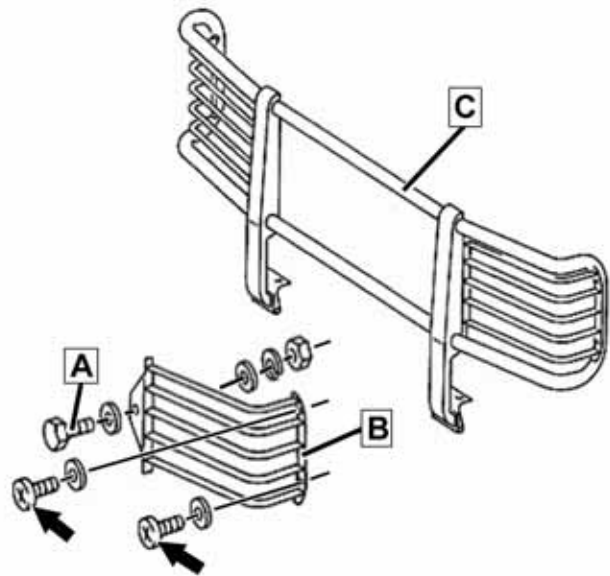

Figure 5

**Note:**

Please print out the "Notice", included with these work instructions, and place in vehicle glove box.

### Primary Parts Information

Qty.	Part Name	Part Number
6	Body Plugs	A000 997 7286

#### Note:

- Please be aware that only the part number(s) referenced in this procedure is/are approved for use to repair the vehicle. Repairs performed using any other part(s) will not have been performed in accordance with the repair. Accordingly, warranty claims submitted with reference to an improper part number(s) will be denied.
- The following allowable labor operation should be used when submitting a warranty claim for this repair:

#### Warranty Information

**Operation:** Remove directional grills and headlamp grills.

Damage Code	Operation Number	Labor Time (hrs.)	Model Indicator(s)
88331 38	88-0000*	0.2	L1, L2, L3, L7

\* Max. time allowed with a separate punch. Ensure that punches are labeled as NON time.