

ATTENTION:
 GENERAL MANAGER
 PARTS MANAGER
 CLAIMS PERSONNEL
 SERVICE MANAGER

IMPORTANT - All
 Service Personnel
 Should Read and
 Initial in the boxes
 provided, right.

QUALITY DRIVEN® SERVICE



SUBARU

PRODUCT CAMPAIGN BULLETIN

APPLICABILITY: 2010MY Subaru Legacy & Outback
SUBJECT: Steering Column Electrical
 Roll Connector

NUMBER: WVR-28
DATE: June 2010

INTRODUCTION

Subaru of America, Inc. has determined that certain 2010 Legacy and Outback models may have been produced with wiring in the steering column electrical roll connector (located behind the vehicle's steering wheel) that may develop stress cracks and eventually break. If breakage occurs, the vehicle could experience any or all of the following conditions:

- The driver's frontal airbag may become inoperative and not deploy as intended during a vehicle crash. Such an event could result in personal injury. Should the driver's side airbag become inoperative, the Supplemental Restraint System (SRS) airbag warning light, located on the instrument panel combination meter, will illuminate indicating a malfunction of the airbag system.
- The horn may not function when the horn pad is pushed. This condition would prevent the driver from sounding the horn in an attempt to avoid a dangerous situation such as a vehicle crash.
- Radio and cruise control switches located on the steering wheel (if equipped) may not function.
- Transmission paddle shifters located behind the steering wheel (if equipped) may not function.

This recall will involve checking the "lot number" found on the steering roll connector. If the "lot number" is within a certain range, the connector must be replaced with a new one. If the "lot number" is not within the range, the connector was manufactured to specifications and replacement is not necessary

AFFECTED VEHICLES

• **2010 Subaru Legacy and Outback**

Potentially affected vehicles are identified in the VIN range chart below. Note: Not all vehicles in the VIN range are affected. Prior to performing repairs, confirm coverage for potentially affected vehicles by using the Vehicle Coverage Inquiry function at Subarunet.com.

Model		From	To
2010MY	Legacy	A*210001	A*244529
	Outback	A*310001	A*377827

*Various Characters may occupy this position

Continued...

CAUTION: VEHICLE SERVICING PERFORMED BY UNTRAINED PERSONS COULD RESULT IN SERIOUS INJURY TO THOSE PERSONS OR TO OTHERS.
 Subaru Service Bulletins are intended for use by professional technicians ONLY. They are written to inform those technicians of conditions that may occur in some vehicles, or to provide information that could assist in the proper servicing of the vehicle. Properly trained technicians have the equipment, tools, safety instructions, and know-how to do the job correctly and safely. If a condition is described, DO NOT assume that this Service Bulletin applies to your vehicle, or that your vehicle will have that condition.

SUBARU OF AMERICA, INC. IS "ISO 14001 COMPLIANT"
 The international standard for excellence in Environmental Management Systems. Please recycle or dispose of automotive products in a manner that is friendly to our environment and in accordance with all local, state and federal laws and regulations.

OWNER NOTIFICATION

SOA will prepare and mail an Owner Notification Letter to owners of the affected vehicles on or around July 7, 2010.

A copy of the Owner Notification Letter is included at the end of this bulletin.

DEALER PROGRAM RESPONSIBILITY

Dealers are to promptly perform the applicable service procedures defined in this bulletin to correct all affected vehicles in their inventory (new, used, demo). Additionally, whenever a vehicle subject to this recall is taken into dealer new or used inventory, or is in the dealership for service, necessary steps should be taken to ensure the recall correction has been made before selling or releasing the vehicle.

New or used vehicles listed in a recall/campaign that are in dealer stock must be:

- Immediately identified.
- Tagged or otherwise marked to prevent their delivery or use prior to inspection and/or repair.
- Repaired in accordance with the repair procedures outlined in this Product Campaign Bulletin.

Please be advised that it is a violation of Federal law for a dealer to deliver a new motor vehicle covered by a recall under a sale or lease until the defect is remedied. Therefore, any Authorized Subaru Dealer failing to perform the applicable service procedures as defined in this bulletin to correct all affected vehicles in their inventory (new, used, demo) prior to the vehicle being placed in service may be subject to civil penalties of up to \$6,000 per violation (i.e., for each vehicle), as provided in 49 CFR §578.6 and will also be in breach of the Subaru Dealer Agreement.

PARTS INFORMATION

Repair parts are available. Each dealer has automatically been sent replacement steering roll connectors equivalent to 20% of their dealer affected VIN list, and one 100 gram tube of steering roll connector grease.

Typically, replacement steering roll connectors are packaged with a small (2 gram) tube of special grease. For the purpose of this recall, the steering roll connectors will be packaged without grease. Instead, a 100 gram tube is available which contains enough special grease to service between 40-50 vehicles.

Dealers will need to order any additional supply through normal parts ordering procedures.

DESCRIPTION	PART NUMBER
Steering Roll Connector	83116AJ02B
Steering Roll Connector Grease	SOA635083 – for claim purposes only, represents 2 grams per repair. (99019AJ00A - 100 gram tube)

Continued...

SERVICE PROCEDURE

This recall will involve checking the "lot number" found on the steering roll connector. If the "lot number" is within a certain range, the connector must be replaced with a new one. If the "lot number" is not within the range, the connector was manufactured to specifications and replacement is not necessary.

Please proceed as follows:

Steering Roll Connector Lot Number Verification

- 1) Start the engine and rotate the steering wheel 90 degrees from a straight-ahead position (either left or right rotation). Turn the ignition switch to the OFF position

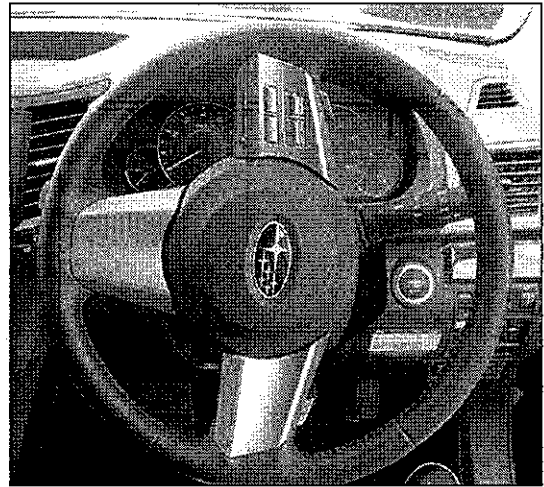
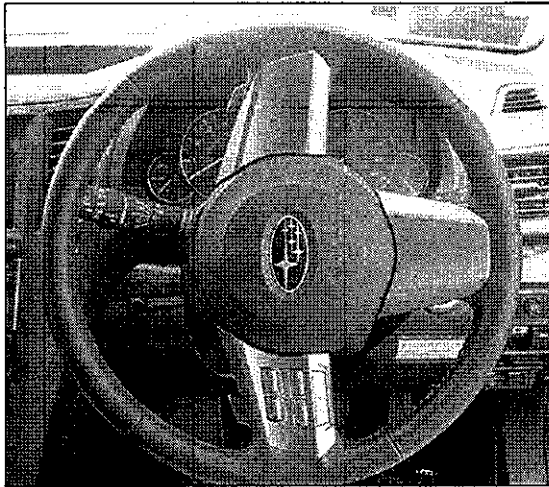

- 2) Adjust the tilt position to the lowest position and lock the tilt lever. Remove the upper steering column cover screw on one side, rotate the steering wheel 90 degrees and remove the screw on the other side.

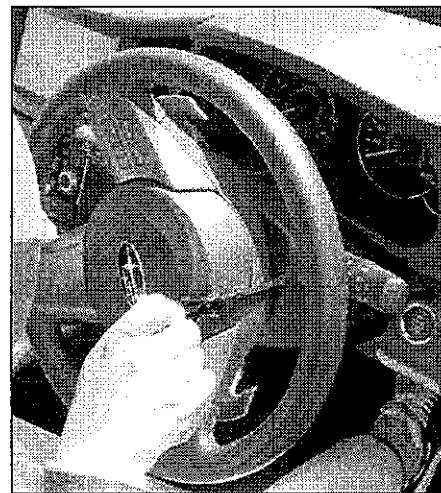
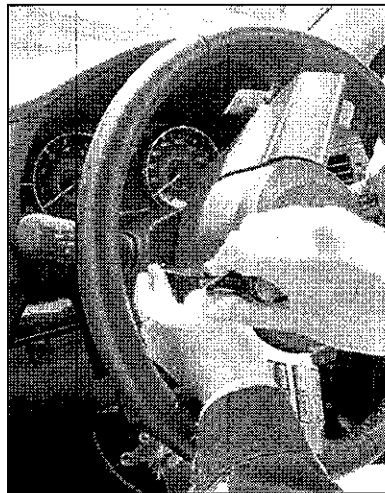

Continued...

3) Release the claws and detach the steering column lower cover.



4) Confirm the steering roll connector lot number located on the left side of the connector.

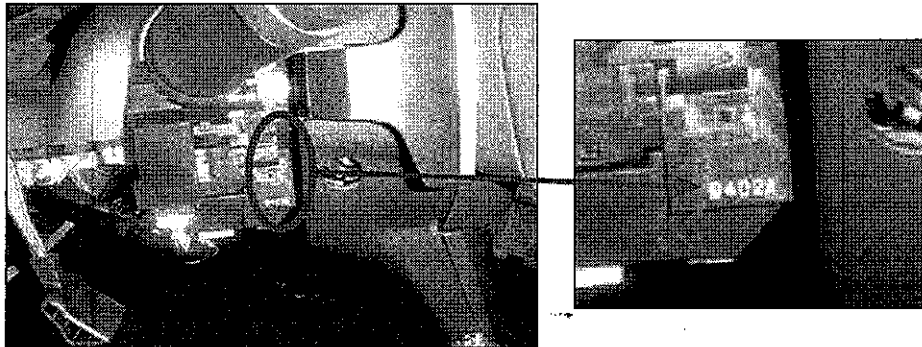

Affected Lot Numbers

Steering Roll Connectors requiring replacement were produced on or before October 13, 2009.

Target Lot Numbers: **9X13A or before.**

How to read the Steering Roll Connector Lot Number:

Lot #: Five Characters

00000

— Production Location - "A" only affected
— Day: 01, 02, 03,30, 31
— Month: 1=Jan, 2=Feb, 3=March...9=Sept, X=Oct, Y=Nov, Z=Dec
— Year: 9=2009, 0=2010

Example: 9402A = April 2, 2009

If the lot number indicates a production date of October 14, 2009 (9X14A) or after, replacement is **not** required. Install the steering column lower cover in reverse order of removal. No further action is required.

If the lot number indicates a production date of October 13, 2009 (9X13A) or before, replacement of the steering roll connector is required. Proceed as follows.

Continued...

Steering Roll Connector Replacement

- 1) Position the front wheels straight ahead. (After moving vehicle 5 m (16 ft) or more with front wheels positioned straight ahead, make sure that the vehicle moves straight ahead).
- 2) Record preset radio stations
- 3) Turn the ignition switch to OFF.
- 4) Disconnect the ground cable from the battery and wait at least 60 seconds before proceeding.
- 5) Remove the driver's airbag module assembly. A TORX® T40 is required. Loosen the two TORX® bolts on the sides of the steering wheel.

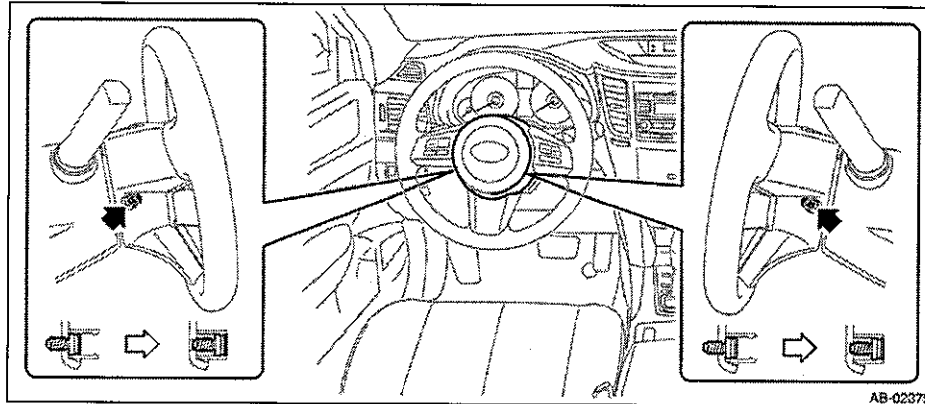

- 6) Disconnect the airbag connector and remove the airbag module assembly as follows:
 - a) Using a flat tip screwdriver, pry the push lock upward to unlock. Pull the connector to disconnect it from the driver's airbag module assembly.
 - b) Disconnect the Horn Harness.

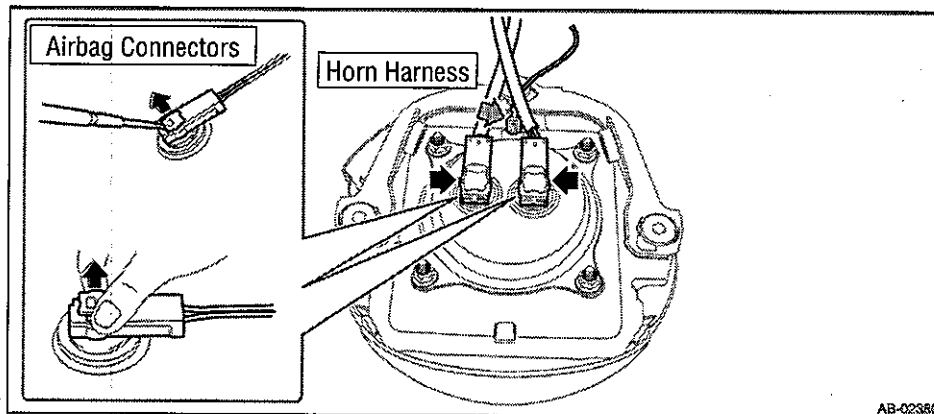

Continued...

7) Remove the steering wheel.

CAUTION:

- Always use the steering wheel puller for removal to avoid deforming the steering wheel.
- Once the steering wheel has been removed, make sure that the roll connector is not rotated from it's original position.

- a) Disconnect the wire harness connector and remove the steering wheel nut.
- b) Make alignment marks on steering shaft and steering wheel and remove the steering wheel.

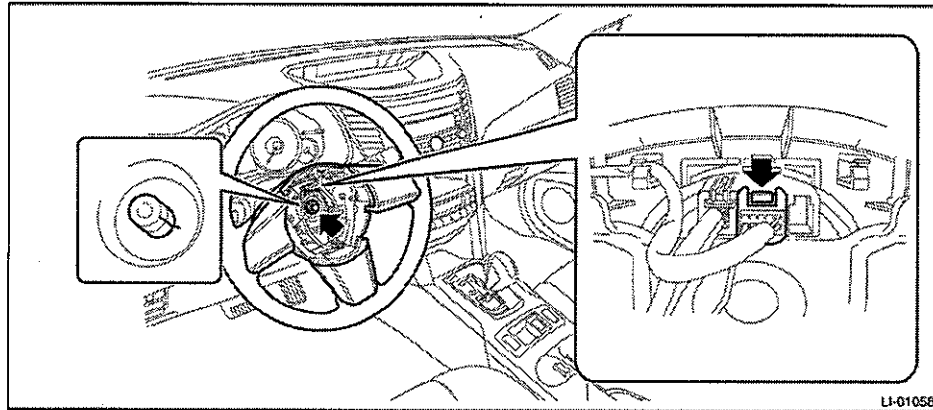

8) Remove the steering column cover.

- a) Lower the lever of the steering column. Remove the steering column upper cover retaining screws, as shown.

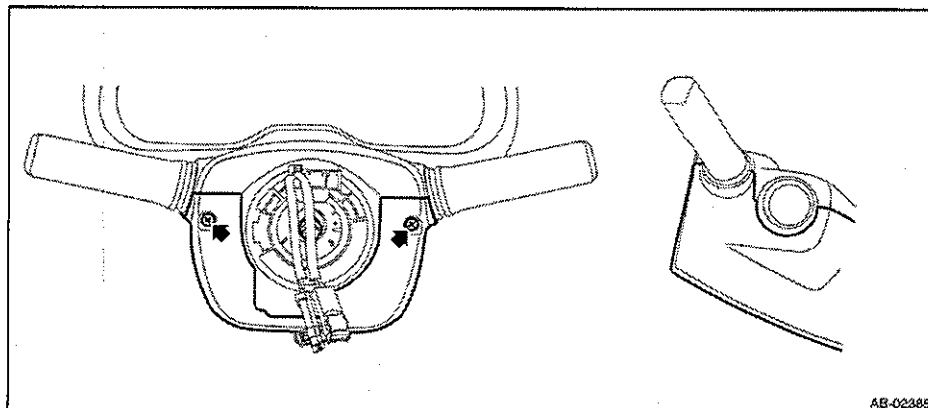

Continued...

- b) Separate the steering column upper cover from the steering column top cover and remove.

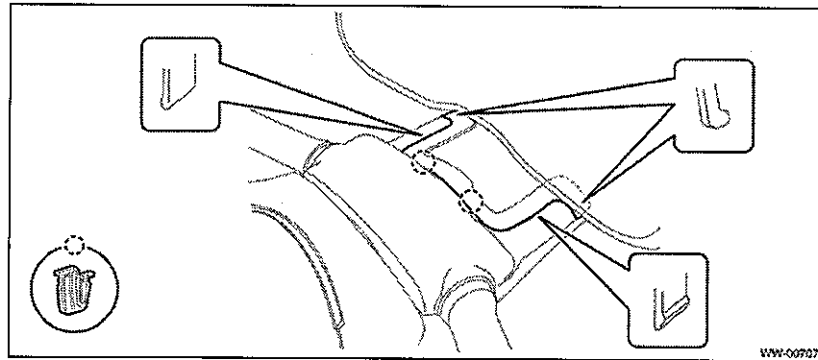

- 9) Remove the roll connector.

CAUTION: Make sure that the roll connector is not turned from the original position.

- (a) Disconnect the connectors under the roll connector.
(b) Release the claws and remove the roll connector.

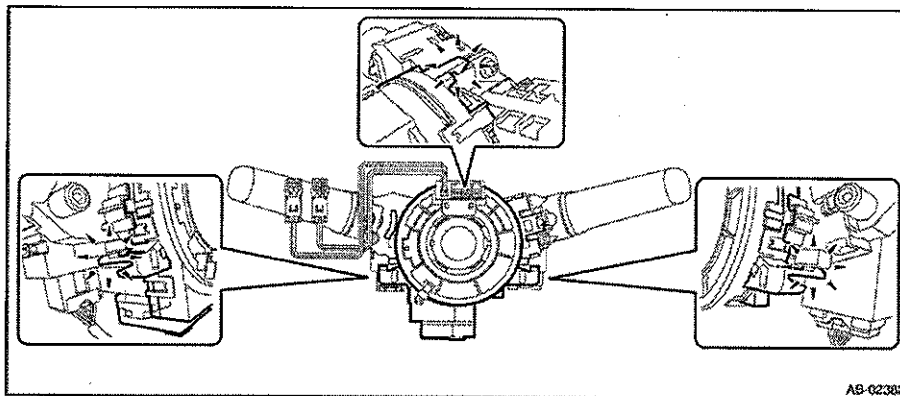

- 10) Remove the steering angle sensor from the roll connector as follows:

Release the claws and remove the steering angle sensor (b) from roll connector (a).

IMPORTANT: Do not rotate the inner ring after removing the steering angle sensor. If you rotate the steering angle sensor 360 degrees, the VDC system will not work properly.

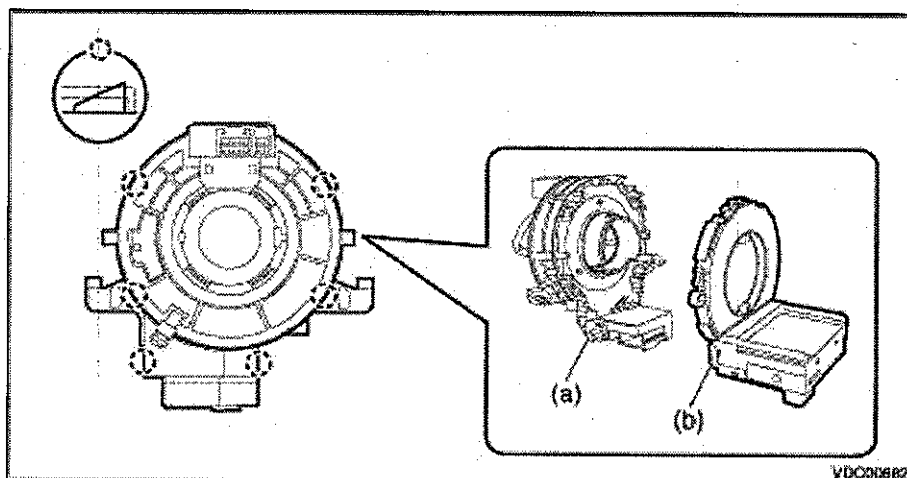

Continued...

CAUTION: Do not rotate the steering angle sensor protrusions (call out "1", as shown).

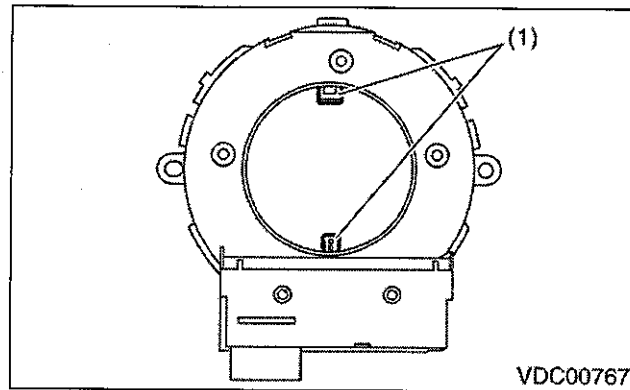

- 11) Install the new steering roll connector as follows:
 - a) Wipe the old grease from the steering angle sensor.
 - b) Apply grease to 4 places on the new steering roll connector as shown in the photo below.
 - c) Align the position of the steering angle sensor protrusion and attach the steering angle sensor to the new steering roll connector. Do not rotate the steering angle sensor protrusion during assembly
- 12) Install the steering roll connector in the vehicle.
- 13) After the new steering roll connector is installed, pull out the roll connector neutral pin.

CAUTION: Do not rotate the steering angle sensor protrusion during installation.

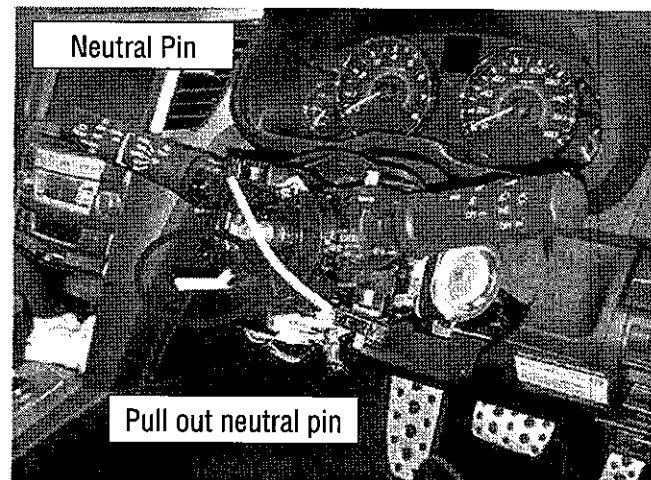
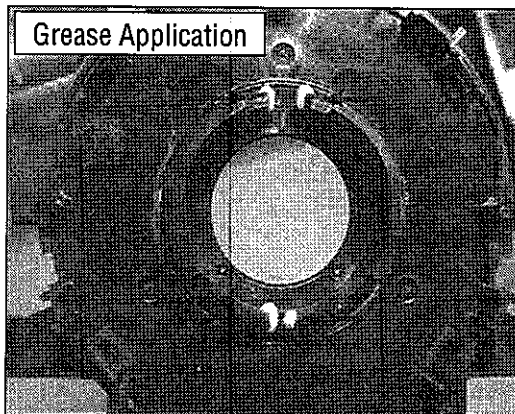

- 14) Reassemble each part in reverse order of removal.

Tightening torque

Airbag module: 10N.m (10kg-f, 7.4ft-lb)

Steering wheel: 39N.m (40kg-f, 28.8ft-lb)

Column cover and steering wheel clearance: 2 - 4mm (0.08 - 0.06 inches)

- 15) Reconnect the Ground Cable to the battery.
- 16) Reset radio stations.

Continued...

After installation, perform the neutral position setting of the steering angle sensor.

Set Up Mode For Steering Angle Sensor

- 1) Set the steering wheel to the neutral position.
- 2) Connect the Subaru Select Monitor.
- 3) On the «Main Menu» display, select {Each System Check}.
- 4) On the «System Selection Menu» display, select {Brake Control System}.
- 5) When {VDC} is displayed, select the [OK] button.
- 6) On the «Brake Control Diagnosis» display, select {Current Data Display & Save}.
- 7) Read {Steering angle sensor value}.
- 8) Check that the displayed value is between - 10 and 10 deg.
- 9) On the «Function Check Sequence» display, select {Set up mode for Neutral of “Steering Angle Sensor & Lateral G Sensor 0 point}}.
- 10) Drive the vehicle for 3 minutes, and check that there is no system malfunction or warning light illumination while driving.
- 11) Make sure that there are no DTCs stored in memory.

SERVICE PROGRAM IDENTIFICATION LABEL

Type or print the necessary information on a recall identification label. The completed label should be attached to the vehicle's upper radiator support.

Additional labels are available through the Subaru Claims Helpline at 1-866-782-2782.

SUBARU
Campaign Code
WVR-28
COMPLETED
DIST./DEALER NO.
SERIAL NO.
DO NOT REMOVE

Continued...

CLAIM REIMBURSEMENT AND ENTRY PROCEDURES

Credit to perform this recall will be based on the submission of properly completed repair order information. Dealers may submit claims through Vehicle Claim Entry on Subarunet.com.

CLAIM TYPE	CAMPAIGN CODE	LABOR	LABOR OPERATION
RC	WVR-28	A182-028 0.2 hrs.	Steering Roll Connector Inspection
		A182-011 0.6 hrs.	Steering Roll Connector Inspect & Replace. Includes setting the steering angle neutral position. (Only applies when connector replacement was necessary)

Continued...

OWNER NOTIFICATION LETTER

Important Safety Recall Notice
Subaru Recall Campaign WVR-28
NHTSA Recall No. 10V-283
July 2010

Dear Subaru Owner:

This notice is sent to you in accordance with the National Traffic and Motor Vehicle Safety Act. SUBARU OF AMERICA, INC. has decided that a defect which relates to motor vehicle safety exists in some 2010 Legacy and Outback models.

DESCRIPTION OF THE SAFETY DEFECT

Subaru has determined that the wiring in the steering column electrical roll connector (located behind your vehicle's steering wheel) may develop stress cracks and eventually break. If this were to happen, certain electrical components may not operate as intended.

DESCRIPTION OF THE SAFETY HAZARD

If the wiring in the steering column electrical roll connector were to break, your vehicle could experience any or all of the following conditions without prior warning:

- The driver's frontal airbag may become inoperative and not deploy as intended during a vehicle crash. Such an event could result in personal injury. Should the driver's frontal airbag become inoperative, the Supplemental Restraint System (SRS) airbag warning light, located on the instrument panel combination meter, will illuminate indicating a malfunction of the airbag system.
- The horn may not function when the horn pad is pushed. This condition would prevent the driver from sounding the horn in an attempt to avoid a dangerous situation such as a vehicle crash.
- Radio and cruise control switches located on the steering wheel (if equipped) may not function.
- Transmission paddle shifters located behind the steering wheel (if equipped) may not function.

REPAIRS

Steering column electrical roll connectors susceptible to this condition contain lot numbers within a specific range. Subaru will check the lot number found on the device and, if necessary, replace it at no charge to you.

WHAT YOU SHOULD DO PROMPTLY

You should immediately contact your Subaru Dealer for an appointment to have this repair performed.

There are important precautions you should take until this recall has been performed. If the Supplemental Restraint System (SRS) airbag warning light illuminates or the horn no longer functions, immediately contact your Subaru dealer for assistance.

Continued...

HOW LONG WILL THE REPAIR TAKE?

The approximate time to perform the inspection is 12 minutes. It will take an additional 24 minutes if the connector requires replacement. However, it may be necessary for you to leave your car for a longer period on the day of your scheduled appointment to allow your dealer flexibility in scheduling other appointments. Your Subaru dealer will perform all inspections and repairs at no cost to you.

Please present this letter to your Subaru Dealer at the time this repair procedure is performed.

CHANGED YOUR ADDRESS OR SOLD YOUR SUBARU?

If you have moved or sold your vehicle, please complete the enclosed prepaid postcard and mail it to us.

IF YOU NEED FURTHER ASSISTANCE:

To locate the nearest Subaru Dealer you can access our website at www.subaru.com and select "Find a Dealer".

If you need additional assistance, please contact us directly:

- Telephone: 1-800-SUBARU3 (1-800-782-2783) Monday through Thursday between 8:30 a.m. and 7:00 p.m. EST and Friday between 10:30 a.m. and 5:00 p.m. EST.
- E-mail: Go to www.subaru.com and select "Contact Us".
- U.S. Postal mail: Write us at: Subaru of America, Inc., Attn: CDS Department,
P.O. Box 6000, Cherry Hill, NJ 08034-6000.

Please contact us immediately if the dealer fails or is unable to make the necessary repairs free of charge.

You may also contact the Administrator, National Highway Traffic Safety Administration, 1200 New Jersey Ave. SE, West Building, Washington, DC 20590 or call the toll free Auto Safety Hotline at 1-888-327-4236 (TTY: 1-800-424-9153) or go to <http://www.safercar.gov> if you believe the dealer has failed or is unable to remedy your vehicle without charge within a reasonable amount of time.

Your continued satisfaction with your Subaru is important to us. Please understand that we have taken this action in the interest of your safety and your vehicle's proper operation. We sincerely apologize for any inconvenience this matter may cause and urge you to schedule an appointment as soon as possible to have this repair performed.

Sincerely,

Subaru of America, Inc

Notice to Lessors

Under Federal law the lessor of a vehicle who receives this letter must provide a copy of it to the vehicle lessee(s) within 10 business days from receipt. The lessor must also keep a record of the lessee(s) to whom this letter is sent, the date sent, and the applicable vehicle identification number (VIN). (For the purposes of this section, a lessor means a person or entity that in the last twelve months prior to the date of this notification has been the owner, as referenced on the vehicle's title, of any five or more leased vehicles. A leased vehicle is a vehicle leased to another person for a term of at least four months.)

A subsidiary of Fuji Heavy Industries Ltd.

Subaru Recall WVR-28 – Steering Column Electrical Roll Connector

TO: SDC EST CEN WST
FROM: Subaru of America, Inc.
DEPARTMENT: Service
DATE: 06/30/2010

The WVR-28 Recall Campaign Bulletin has been posted on the Techinfo.Subaru.com website.

Dealer affected VIN lists will be mailed on or around July 1, 2010.

Owner notification letters are scheduled for mailing on July 7, 2010.

[Back to List](#)
