

IMPORTANT INFORMATION

Please inform and provide a copy of this document to every person in your dealership with campaign-related responsibilities, including Service, Parts and Accounting personnel. By law, dealers must correct, prior to delivery for sale or lease, any vehicle that fails to comply with an applicable Federal Motor Vehicle Safety Standard or that contains a defect relating to motor vehicle safety. **If you have questions regarding this or any other campaign, please call USA: (866) 306-8447 / CANADA: Contact your respective claim specialist.**



Safety Recall Circular

Code: **97S8**

REVISED

**Subject: 2009 Routan
Power Sliding Door Wiring Harness Assembly**

October 20, 2010

Revision Summary

SAGA claim instructions updated – page 2

Problem Description

A right and/or left power sliding door wiring harness may chafe on a sliding door hinge when that door is operated. If this happens, a sliding door latch can overheat and cause a fire inside the door.

Corrective Action

Inspect and, as necessary repair or replace the left and right power sliding door wiring harness.

VIN Range & Production Date of Affected Vehicles

(U.S.A.)

2V8_W_4X_9R500096 - 2V8_W_4X_9R609638

Production date: June 26, 2008 – December 16, 2008

(Canada)

2V8_W_4X_9R500158 - 2V8_W_4X_9R588735

Production date: August 22, 2008 – December 4, 2008

NOTE: Check ElsaWeb on the day of repair to verify vehicle eligibility and attach the screen print to the repair order. This is the only valid campaign inquiry and verification source. Some vehicles may be involved in an additional action(s); any additional work can be done while the vehicle is in for this action.

Allocation Report of Affected Vehicles

Electronic allocation lists will be posted under My Dealership Reports on the VW Hub on or about October 15, 2010. A list will not be posted for dealers who have no affected vehicles.

Parts Information and Allocation

Dealers will receive an allocation of tab/wedge packages prior to customer notification. If you have exhausted your allocated parts but have exceeded your weekly upper order limit, please submit your requests for additional parts via email to upperorderlimits@vw.com. No other parts will be allocated due to the very small number of vehicles expected to need wiring repairs or wiring harness replacements.

Due to limited parts supply, wire splice band packages and power sliding door wiring harnesses will be blocked from the regular ordering process. Dealers with vehicles

requiring these components must contact Warranty with the VIN and part number(s) required. Warranty will verify that the VIN is included in the 97S8 campaign and request Parts Special Services to fulfill the dealer's parts order.

Owner Notification Mailing

On or about October 15, 2010 Volkswagen will notify all known owners of affected vehicles by first class mail. A sample copy of the owner letter is enclosed.

Campaign Completion Labeling Guidelines

Vehicles repaired under this action must be identified with a campaign completion label (part number CAMP 010 000). Labels can be ordered at no cost online via the Compliance Label Ordering portal at www.vwclub.com.

MANDATORY PARTS RETURN REQUIREMENT

Any power sliding door wiring harness replaced under this action MUST be returned. The SAGA system will generate a part request bar code for this campaign if a wiring harness is on the claim. Reference Section G of the work procedure for complete shipping instructions.

Claims will be debited if:

- a harness is replaced but not returned, or
- if the harness was replaced unnecessarily (i.e., returned but found to be undamaged or having less than three wires damaged).

Claim Entry Procedure

Immediately upon completion of the repair work, enter the Applicable Criteria ID and Repair Operation from the following chart. **The Applicable Criteria ID is shown in ElsaWeb.** Claims will only be paid for vehicles that show this campaign open in ElsaWeb on the day of the repair. To help ensure prompt and proper payment, attach the screen print to the repair order.

Saga Claim Entry Procedure

Check ElsaWeb to determine whether the "97S8" campaign is open.

Service No.: 97S8

Damage Code: 0099

HST Number (required for Routan): CRM2023766

REVISED

Parts Manufacturer

Removed part: Use vendor code USM.

Sold vehicle = 7 10

Unsold vehicle = 7 90

Accounting Instructions

CRITERION 01

Inspect driver & passenger side power sliding door wiring harness and chain link track; tie strap/route harness under weather strip and install tab/wedge

Driver & Passenger side Repair operation: 9732 36 99 20 T.U.

<u>Qty</u>	<u>Part Number</u>	<u>Description</u>
1	7B0 898 173	Tab/wedge package
1	7B0 971 818	Tie wrap

NOTE

All claims MUST include the parts and labor for installation of tab/wedge package

AND -

ADD ANY OF THE FOLLOWING, IF APPLICABLE, ACCORDING TO THE VEHICLE REPAIRS REQUIRED

Repair sliding door wiring harness

Driver side (left) Repair operation 9732 41 99 70 TU

<u>Qty</u>	<u>Part Number</u>	<u>Description</u>
1	7B0 979 941 A	Wire splice band package (16 AWG)

Passenger side (right) Repair operation 9732 42 99 70 TU

<u>Qty</u>	<u>Part Number</u>	<u>Description</u>
1	7B0 979 941 A	Wire splice band package (16 AWG)

Repair drive motor wiring harness

Driver side (left) Repair operation 9732 49 99 70 TU

<u>Qty</u>	<u>Part Number</u>	<u>Description</u>
1	7B0 979 941	Wire splice band package (12 AWG)
	and/or	
1	7B0 979 941B	Wire splice band package (20 AWG)

Passenger side (right) Repair operation 9732 50 99 70 TU

<u>Qty</u>	<u>Part Number</u>	<u>Description</u>
1	7B0 979 941	Wire splice band package (12 AWG)
	and/or	
1	7B0 979 941B	Wire splice band package (20 AWG)

Replace sliding door wiring harness

Driver side (left) Repair operation 9732 55 99 50 TU

<u>Qty</u>	<u>Part Number</u>	<u>Description</u>
1	7B0 971 301 H	Harness, Power Sliding Door (left)

Passenger side (right) Repair operation 9732 56 99 40 TU

<u>Qty</u>	<u>Part Number</u>	<u>Description</u>
1	7B0 971 302H	Harness, Power Sliding Door (right)

NOTE

Mark wiring harness as causal
If replacing two harnesses, mark only one as causal
To avoid claim being debited, removed harness(es) must be returned

There is NO reimbursement for Vehicle Wash or Loaner

If customer refused repairs

Fax the repair order to Volkswagen at (248) 754-5093 and provide the VIN, applicable service number, customer information, dealer number and date.

The information in this document is intended for use only by skilled technicians who have the proper tools, equipment and training to correctly and safely maintain your vehicle. These procedures are not intended to be attempted by "do-it-yourselfers," and you should not assume this document applies to your vehicle, or that your vehicle has the condition described. To determine whether this information applies, contact an authorized Volkswagen dealer. ©2010 Volkswagen Group of America, Inc. and Volkswagen Canada Inc. All Rights Reserved.

October 20, 2010

REVISED 97S8/T7 Page 2 of 34

97S8 Safety Recall Campaign TABLE OF CONTENTS



Saga Claim Entry Procedure	Page 2
Required Parts	Page 6
Required Tools	Page 6
Repair Summary Flow Chart	Page 7
<u>Work Procedure</u>	
Section A – Inspect Chain Link Track and Wiring Harnesses	Page 8
Section B – Power Sliding Door Wiring Harness Removal	Page 10
Section B2 – Power Sliding Door Wiring Harness Installation	Page 15
Section C – Tie Wrap and Tab/Wedge Installation	Page 20
Section D – Wiring Harness Repair	Page 22
Section E – Restoring Power	Page 33
Section F – Applying the Campaign Label	Page 34
Section G – Part Return	Page 34

Customer Letter Example (U.S.A.)

October 2010

<CUSTOMER NAME>
<CUSTOMER ADDRESS>
<CUSTOMER CITY STATE ZIPCODE>

Vehicle Identification Number (VIN): <VIN>

**Subject: Safety Recall 97S8/T7 – Power Sliding Door Wiring Harness Assembly
2009 Model Year Volkswagen Routan**

Dear Volkswagen Owner:

This notice is sent to you in accordance with the requirements of the National Traffic and Motor Vehicle Safety Act. Volkswagen has decided that a defect, which relates to motor vehicle safety, exists in some 2009 model year Volkswagen Routan vehicles. Our records show that you are the owner of one of these vehicles.

What Is The Problem?

A right and/or left side power sliding door wiring harness may chafe on a sliding door hinge when that door is operated. If this happens, a sliding door latch can overheat and cause a fire inside the door.

What Will Volkswagen Do?

In order to identify and correct this defect, dealers will inspect and, as necessary, repair or replace the left and right power sliding door wiring harness in your vehicle.

What We Would Like You to Do

Please contact your authorized Volkswagen dealer and arrange for an appointment to have your vehicle inspected and repaired without delay.

The inspection will take less than one hour, and repairs (if necessary) may take an additional hour. This work will be performed for you free of charge. Please keep in mind that your dealer may need additional time for the preparation of the repair, as well as to accommodate their daily workshop schedule.

Precautions You Should Take

Affected vehicles can continue to be driven as usual, but if the vehicle experiences a power sliding door-related concern at any time, please have the vehicle inspected by an authorized Volkswagen dealer immediately.

Lease Vehicles

If you are the lessor and registered owner of the vehicle identified in this action, the law requires you to forward this information immediately via first-class mail to the lessee within ten (10) days of receipt of this notification.

Have You Changed Your Address Or Sold The Vehicle?

If you have, please fill out the enclosed prepaid Owner Reply card and mail it to us so we can update our records.

Reimbursement of Expenses

If you have previously paid for repairs relating to a chafed power sliding door wiring harness as described in this letter, the enclosed form explains how to request reimbursement. We would be pleased to review your reimbursement request.

Service Help from Us

If your authorized Volkswagen dealer fails or is unable to complete this work free of charge within a reasonable time, please call or write to:

*Volkswagen of America, Inc.
Attn: Customer CARE Center – Hills East (97S8/T7)
3499 West Hamlin Road
Rochester Hills, MI 48309
1-800-893-5298*

If you still cannot obtain satisfaction, you may file a complaint with: The Administrator, National Highway Traffic Safety Administration, 1200 New Jersey Avenue, SE., Washington, DC 20590; or call the toll-free Vehicle Safety Hotline at 1-888-327-4236 (TTY: 1-800-424-9153); or go to <http://www.safercar.gov>.

We also invite you to visit our website at www.vw.com, where you can check to see if this or any other action may be open on your vehicle.

We apologize for any inconvenience this matter may cause; however we are taking this action to help ensure your safety and continued satisfaction with your vehicle. Thank you for driving a Volkswagen!

Sincerely,

Volkswagen Product Compliance

The information in this document is intended for use only by skilled technicians who have the proper tools, equipment and training to correctly and safely maintain your vehicle. These procedures are not intended to be attempted by "do-it-yourselfers," and you should not assume this document applies to your vehicle, or that your vehicle has the condition described. To determine whether this information applies, contact an authorized Volkswagen dealer. ©2010 Volkswagen Group of America, Inc. and Volkswagen Canada Inc. All Rights Reserved.

Customer Letter Example (CANADA)

October 2010

<CUSTOMER NAME>
<CUSTOMER ADDRESS>
<CUSTOMER CITY STATE ZIPCODE>

Vehicle Identification Number (VIN): <VIN>

**Subject: Safety Recall 97S8/T7 – Power Sliding Door Wiring Harness Assembly
2009 Model Year Volkswagen Routan**

Dear Volkswagen Owner:

This notice is sent to you in accordance with the requirements of the Canadian Motor Vehicle Safety Act. Volkswagen has decided that a defect, which relates to motor vehicle safety, exists in some 2009 model year Volkswagen Routan vehicles. Our records show that you are the owner of one of these vehicles.

What Is The Problem?

A right and/or left side power sliding door wiring harness may chafe on a sliding door hinge when that door is operated. If this happens, a sliding door latch can overheat and cause a fire inside the door.

What Will Volkswagen Do?

In order to identify and correct this defect, dealers will inspect and, as necessary, repair or replace the left and right power sliding door wiring harness in your vehicle.

What We Would Like You to Do

Please contact your authorized Volkswagen dealer and arrange for an appointment to have your vehicle inspected and repaired without delay.

The inspection will take less than one hour, and repairs (if necessary) may take an additional hour. This work will be performed for you free of charge. Please keep in mind that your dealer may need additional time for the preparation of the repair, as well as to accommodate their daily workshop schedule.

Precautions You Should Take

Affected vehicles can continue to be driven as usual, but if the vehicle experiences a power sliding door-related concern at any time, please have the vehicle inspected by an authorized Volkswagen dealer immediately.

Lease Vehicles

If you are the lessor and registered owner of the vehicle identified in this action, the law requires you to forward this information immediately via first-class mail to the lessee within ten (10) days of receipt of this notification.

Have You Changed Your Address Or Sold The Vehicle?

If you have, please fill out the enclosed prepaid Owner Reply card and mail it to us so we can update our records.

Reimbursement of Expenses

If you have previously paid for repairs relating to a power sliding door wiring harness malfunction as described in this letter, the enclosed form explains how to request reimbursement. We would be pleased to review your reimbursement request.

Service Help from Us

If your authorized Volkswagen dealer fails or is unable to complete this work free of charge within a reasonable time, please call or write to:

*Volkswagen Canada
Attn: Customer CARE Center (97S8/T7)
P.O. Box 842, Stn. A
Windsor, ON N9A 9Z9
1-800-893-5298*

We also invite you to visit our website at www.vw.ca, where you can check to see if this or any other action may be open on your vehicle.

We apologize for any inconvenience this matter may cause; however we are taking this action to help ensure your safety and continued satisfaction with your vehicle. Thank you for driving a Volkswagen!

Sincerely,

Volkswagen Product Compliance

The information in this document is intended for use only by skilled technicians who have the proper tools, equipment and training to correctly and safely maintain your vehicle. These procedures are not intended to be attempted by "do-it-yourselfers," and you should not assume this document applies to your vehicle, or that your vehicle has the condition described. To determine whether this information applies, contact an authorized Volkswagen dealer. ©2010 Volkswagen Group of America, Inc. and Volkswagen Canada Inc. All Rights Reserved.

October 20, 2010

REVISED 97S8/T7 Page 5 of 34

Campaign Work Procedure

97S8 Safety Recall

If there are questions regarding the work procedure, USA call: (866) 306-8447 /
 CANADA: Contact your respective claim specialist.

Required Parts

<u>Qty.</u>	<u>VW Part Number</u>	<u>Description</u>	<u>Chrysler Part Number</u>
1	7B0 898 173	Tab/wedge Package	CATFK143AA
1	7B0 971 302H	Harness, Power Sliding Door (right)	CATFK142AA
1	7B0 971 301H	Harness, Power Sliding Door (left)	CATFK141AA
1	7B0 971 818	Tie Wrap	CLG0J061AA
1	7B0 979 941	Wire Splice Band Package (12 AWG)	05018528AA
1	7B0 979 941A	Wire Splice Band Package (16 AWG)	05018526AA
1	7B0 979 941B	Wire Splice Band Package (20 AWG)	05018395AA

Required Tools



- VAS 1978B – Wiring Repair Kit
- VAS 1978/1-2 – Crimping Pliers (Base tool)
(Included in the VAS 1978B Wiring Repair Kit)



- 1184-13102 – CSV 10, AWG 22-16 Crimp Tool Head
- 1184-15102 – CSV 10, AWG 16-12 Crimp Tool Head



- UTI-100SI Ultratorch
(Included in the VAS 1978B Wiring Repair Kit)
- VAS 1978/3 Wire Stripper (or equivalent)
(Included in the VAS 1978B Wiring Repair Kit)



- 80-200 Pry lever (or equivalent)
- RMCP101 – Bone tool for trim (or equivalent)

The information in this document is intended for use only by skilled technicians who have the proper tools, equipment and training to correctly and safely maintain your vehicle. These procedures are not intended to be attempted by "do-it-yourselfers," and you should not assume this document applies to your vehicle, or that your vehicle has the condition described. To determine whether this information applies, contact an authorized Volkswagen dealer. ©2010 Volkswagen Group of America, Inc. and Volkswagen Canada Inc. All Rights Reserved.

Repair Summary: The power sliding door wiring harness and the drive motor wiring harness must be inspected for damage and repaired/replaced as necessary. The two harnesses must then be tie strapped together and routed under the sliding door weather strip and a tab/wedge installed on each sliding door lower hinge bracket.

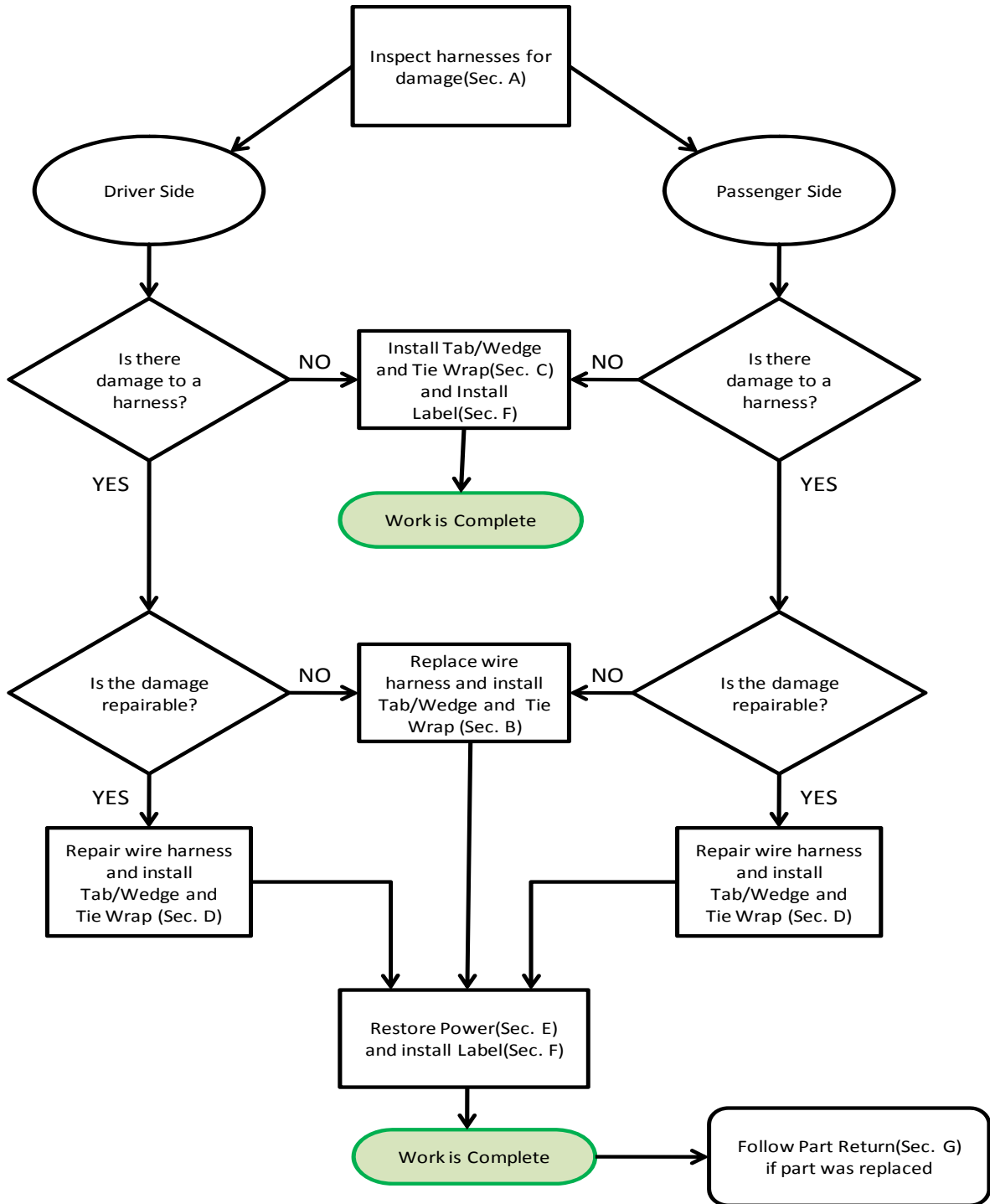



Tip: If Campaign Completion label is present, no further work is required

Section A – Inspect Chain Link Track and Wiring Harnesses



Tip: This procedure is shown on the driver side. Perform the following assessment on each door

- Open power sliding door

⇐ Partially remove sliding door weather seal -1-



Note: Take precautions to protect vehicle interior from weather seal dirt, grease, etc. -1-

Damage caused by contamination is not covered by this action

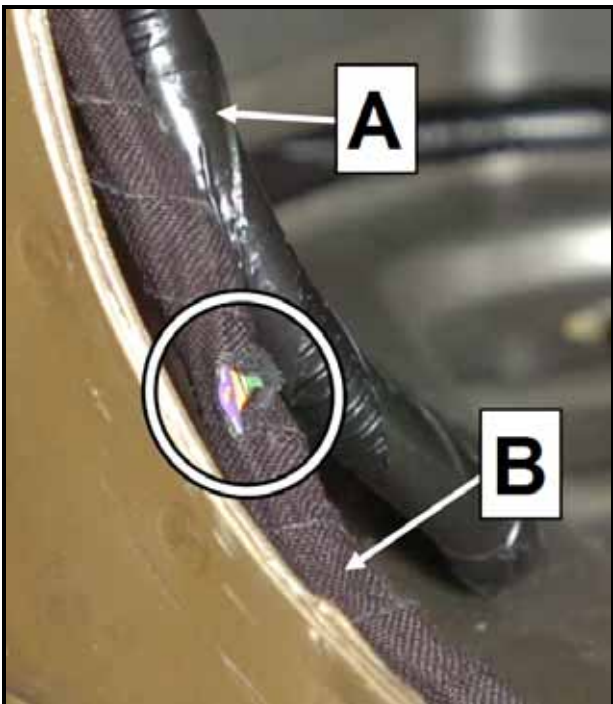

⇐ Inspect drive motor wiring harness -A- and door track wiring harness -B- for a wire chafe condition -circle-



Tip: Wire chafe condition -circle- is only an example

Wire chafe conditions may differ in appearance and may be present on either one or both harnesses

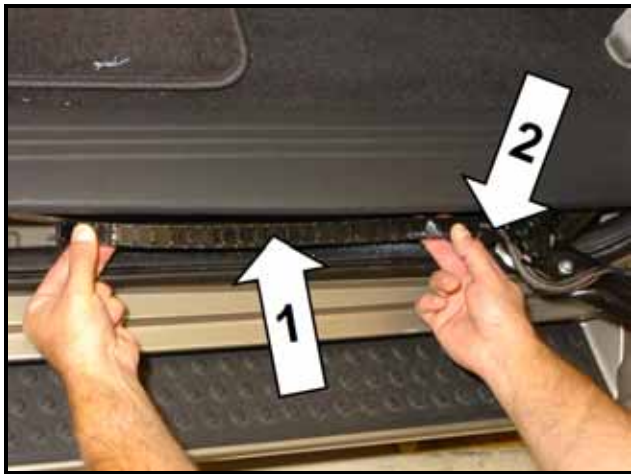

- ⇐ Inspect chain link track -arrow 1- for broken links, damaged wires, or the chain link track being disconnected from lower hinge bracket -arrow 2-
 - If there is no damage to either wiring harness or the chain link track, **go to Section C**
 - If no more than two wires are damaged on the power sliding door wiring harness and/or if up to four wires are damaged on the drive motor wiring harness, **go to Section D** for wiring repairs
 - If chain link track is disconnected or damaged, and/or more than two wires on the power sliding door wiring harness(es) are damaged, **go to Section B** to replace the harness(es)

Repair vs. Replace Summary Chart

Harness	Condition	Work	Go to Section
Sliding Door Harness	One or two wires damaged	Repair harness	D
Sliding Door Harness	More than two wires damaged	Replace harness	B
Sliding Door Harness	Chain link disconnected or damaged	Replace harness	B
Drive Motor harness	up to 4 wires damaged	Repair harness	D

Section B – Power Sliding Door Wiring Harness Removal



WARNING!

To avoid serious or fatal injury on vehicles equipped with airbags, disable the supplemental restraint system before attempting any steering wheel, steering column, airbag, occupant classification system, seat belt tensioner, impact sensor, or instrument panel component diagnosis or service.

Disconnect and isolate the battery negative cable, then wait two minutes for the system capacitor to discharge before performing further diagnosis or service. This is the only sure way to disable the supplemental restraint system.

Failure to take the proper precautions could result in accidental airbag deployment.



WARNING!

Electrostatic discharges can lead to an unintended deployment of the airbag.

The technician must discharge static electricity from the body before working on the airbag system. This is done, for example, by briefly touching the vehicle body or the door striker or pin.



WARNING!

To avoid serious or fatal injury, never strike or drop the side impact sensor, as it can damage the impact sensor or affect its calibration. The side impact sensor enables the system to deploy the side Supplemental Restraint System components.

If an impact sensor is accidentally dropped during service, the sensor must be scrapped and replaced with a new unit. Failure to observe this warning could result in accidental, incomplete, or improper side SRS component deployment.



Tip: This procedure is shown on the driver side. Perform procedure on both sides of vehicle, if necessary

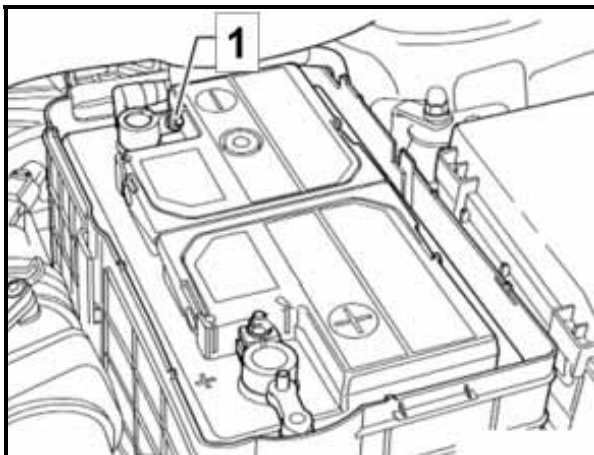

- Place both front seats to the full forward travel position



Tip: This seat position will allow access to all trim panels during the repair procedure

- Record all radio presets and comfort settings
 - Open hood
- ⇐ Disconnect battery terminal clamp of Ground (GND) wire -1- from battery Ground (GND) terminal



Note: Use care when removing plastic trim panels when cold



Note: Ensure that wiring harnesses are tucked behind the weather seal retaining lip

- Remove protective cap and screw at umbrella tray on driver side only



⇐ Using trim removal wedge RMCP101 or equivalent, gently pull up on inside edge of the sill plate to disengage clips from body and remove front door sill plate -arrow- from vehicle



⇐ Using trim removal wedge RMCP101 or equivalent, gently pull up on inside edge of the sliding door sill plate -arrow- to disengage clips from body and remove sliding door sill plate from vehicle



⇐ Using trim removal wedge RMCP101 or equivalent, gently remove lower B-pillar trim -arrow 1- and disconnect the power sliding door switch -arrow 2- from the body wiring harness connector and remove lower B-pillar trim from vehicle

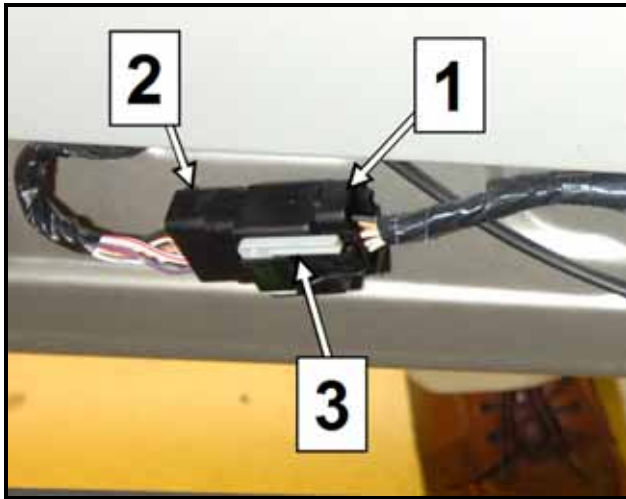

⇐ Disconnect 10-pin power sliding door wiring harness connector -1- from sliding door wiring harness connector -2- by first pushing the gray locking tab -3- upward (downward on the passenger side) and pushing down on the release tab while separating the connector

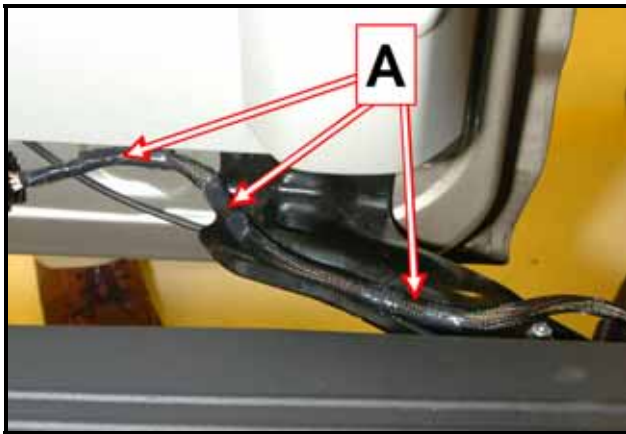

⇐ Using Pry Lever tool 80-200 or equivalent, remove sliding door wiring harness from sliding door and lower hinge bracket by carefully pulling wiring harness retainers out of the retention holes -A-

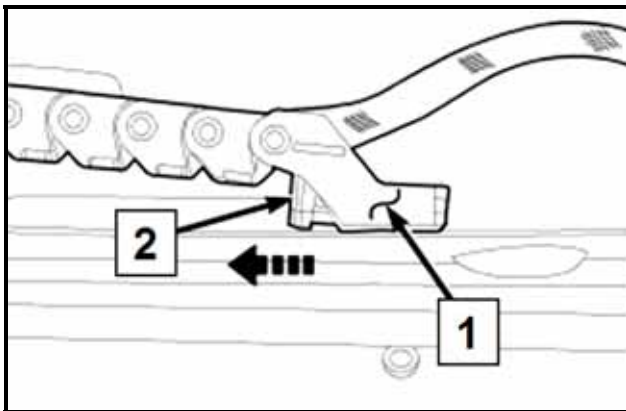

⇐ Disengage locking tab -2- by pulling in -direction of arrow- to release wire harness chain link clip

⇐ Pull chain link -1- down off of mounting pin on the sliding door lower hinge



- ⇐ Move power sliding door wiring harness and chain link track forward to gain access to second row seating side impact sensor and disconnect electrical connector, as shown



Tip: The passenger side wiring harness has one additional wiring harness retainer at the second row seating side impact sensor, as seen in picture

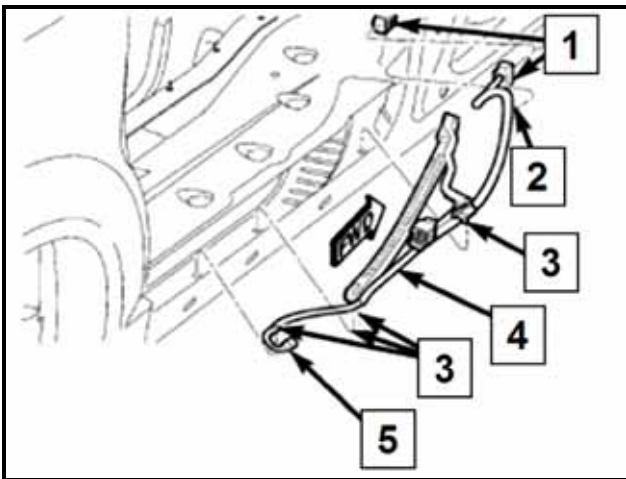

- ⇐ Disconnect 10-pin power sliding door harness connector -1- from body harness connector at the lower B-pillar



Tip: Push red locking tab in direction of power sliding door harness, then push down on release tab while separating the connectors -1-

- ⇐ Using pry lever tool 80-200 or equivalent, remove wire harness clips -3- located under the drive assembly push pin clip -2- near the B-pillar
- ⇐ Pull harness -4- out of the body channel and remove from vehicle

Section B2 – Power Sliding Door Wiring Harness Installation

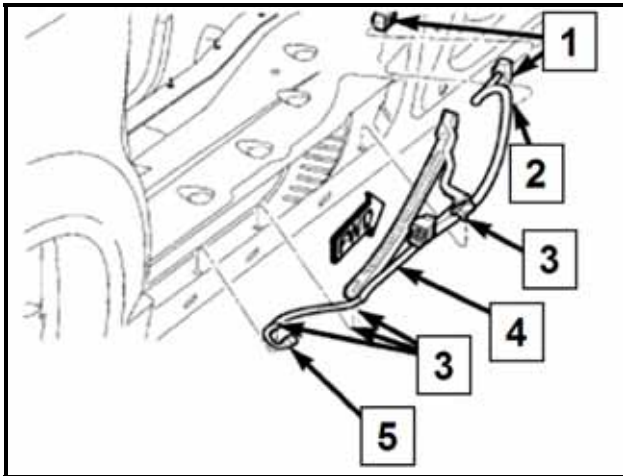

(Driver side)

- ⇐ Position the new wire harness, part number 7B0 971 301H, -4- into the sliding door track cavity and install the push pin clips -3- located under the drive assembly
- ⇐ Install push pin clip -2- at the B-pillar
- ⇐ Connect 10-pin power sliding door wiring harness connector to body wiring harness connector -1- located at the lower B-pillar and slide the red locking tab in the direction of the body wiring harness



WARNING!

Ensure that no person is inside of vehicle when connecting side impact sensor.



WARNING!

Electrostatic discharges can lead to an unintended deployment of the airbag.

The technician must discharge static electricity from the body before working on the airbag system. This is done, for example, by briefly touching the vehicle body or the door striker or pin.

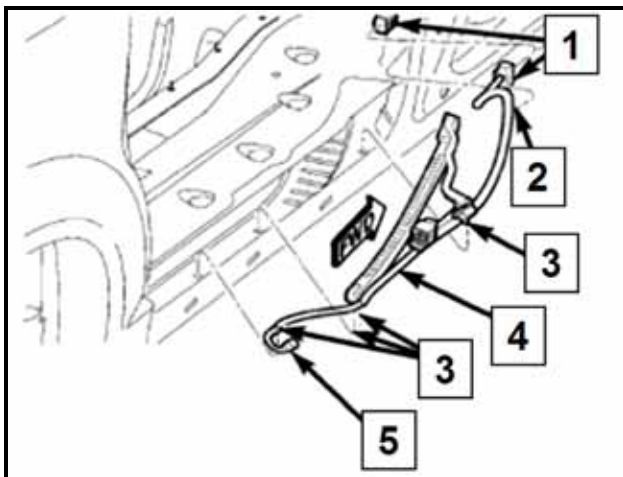

- ⇐ Connect new wiring harness to the second row seating side impact sensor electrical connector -5-



Tip: The passenger side wiring harness, part number 7B0 971 302H, has one additional wiring harness retainer at the second row seating side impact sensor

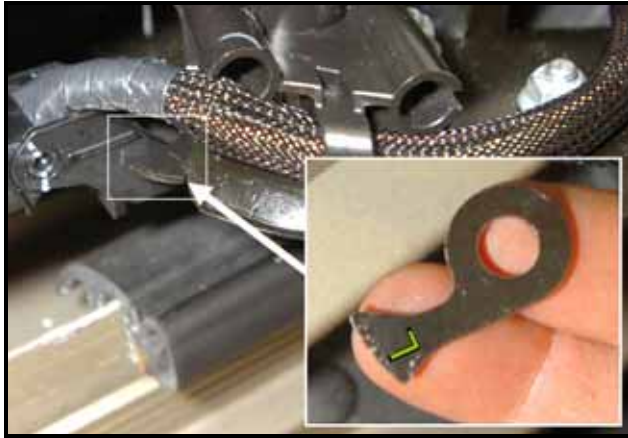

- Move the chain link track and wiring harness rearward
- ⇐ Install supplied tab/wedge, part number 7B0 898 173, to the chain link pivot located on sliding door lower hinge

⚠ Note: The tab/wedge must have the “L” facing up on driver side of vehicle and the “R” facing up on passenger side of vehicle

- While holding the tab/wedge in place, snap the chain link to the lower hinge bracket pivot

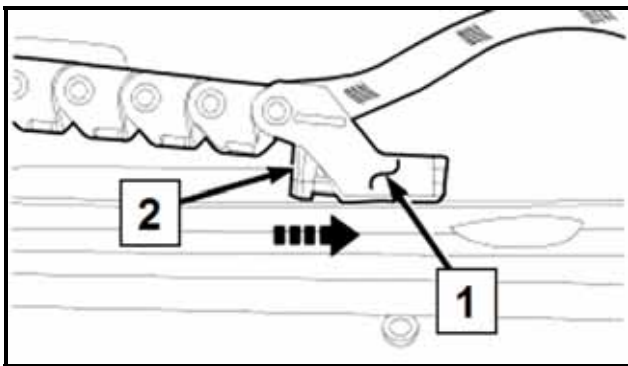

- ⇐ Lock chain link -1- in place by pushing the locking tab -2- rearward -in direction of arrow-

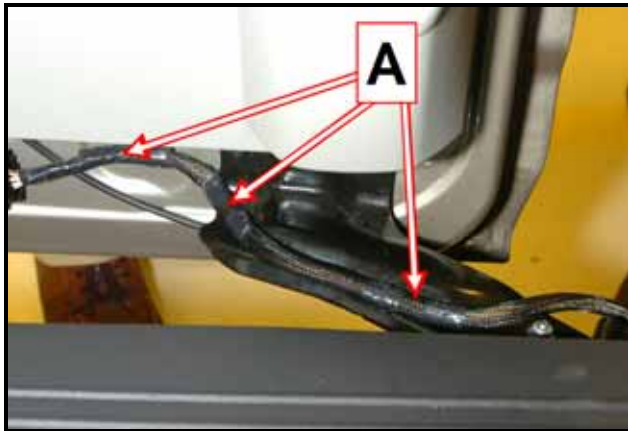

- ⇐ Insert power sliding door wiring harness retainers into lower hinge and sliding door retention holes at positions -A-

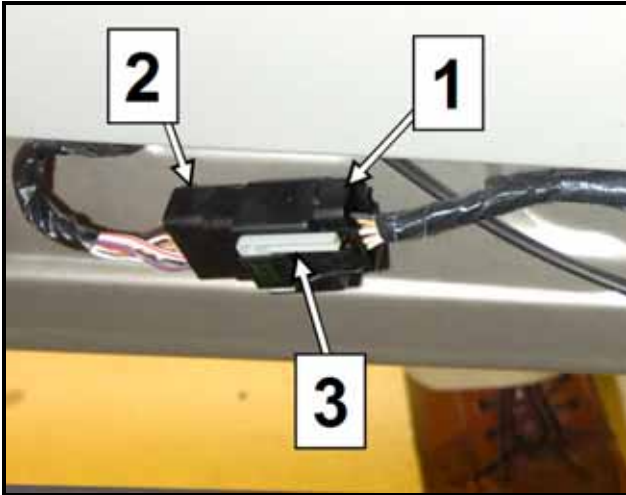

⇐ Connect 10-pin power sliding door wiring harness connector -1- into sliding door wiring harness connector -2- and slide gray locking tab -3- downward (upward on passenger side)



⇐ Reconnect power sliding door switch -arrow 2- to body wiring harness connector and reinstall lower B-pillar trim -arrow 1-



⇐ Reinstall sliding door sill plate -arrow-



⇐ Reinstall front door sill plate -arrow-



- Reinstall screw and protective cap for umbrella tray on driver side only

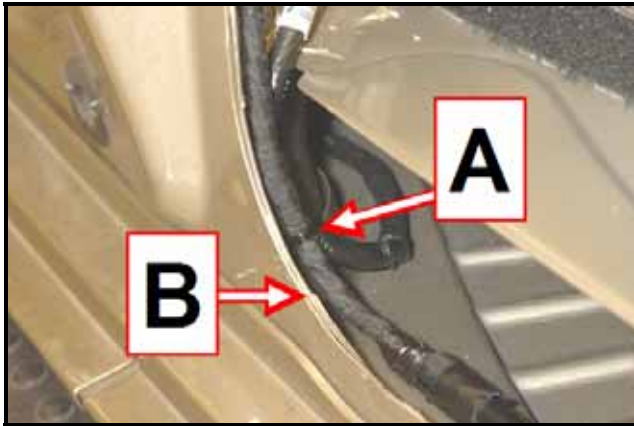

- Position both harnesses together, as shown, where drive unit harness is positioned behind new power sliding door wiring harness
- ⇐ Carefully bind both harnesses together using tie wrap, part number 7B0 971 818, -A- just above sheet metal division -B-
- Cut off excess tie wrap and position tie wrap lock to the rear of the harnesses



WARNING!

Do not over tighten tie wrap.

Over tightening the tie wrap may cut through the conduit and/or tape.

- Reinstall partially removed sliding door weather seal



Note: Ensure that wiring harnesses are tucked behind the weather seal retaining lip

- Move door manually and verify that lower hinge does not contact weather seal and/or any portion of the wiring harnesses
- Address opposite side as necessary
- For restoring power, go to Section E

Section C – Tie Wrap and Tab/Wedge Installation

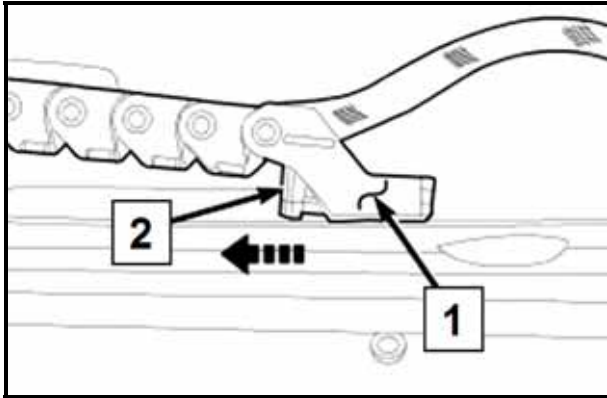

Tip: This procedure is shown on the driver side. Perform procedure on both sides of vehicle as outlined by inspection

- ⇐ Disengage locking tab -2- by pulling -in direction of arrow- to release wire harness chain link clip
- ⇐ Pull chain link -1- down off of mounting pin on sliding door lower hinge



Note: The tab/wedge must have the “L” facing up on driver side of vehicle and the “R” facing up on passenger side of vehicle

- While holding the tab/wedge in place, snap the chain link to the lower hinge bracket pivot

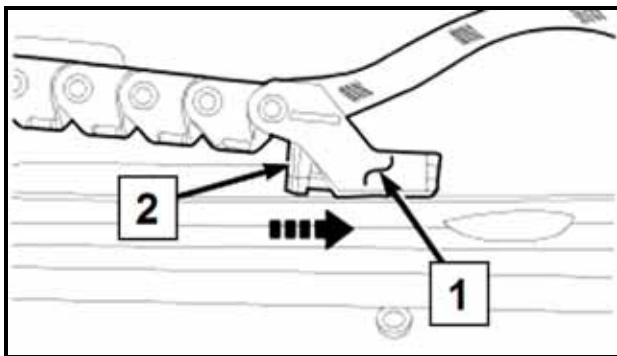

- ⇐ Lock chain link -1- in place by pushing the locking tab -2- rearward -in direction of arrow-

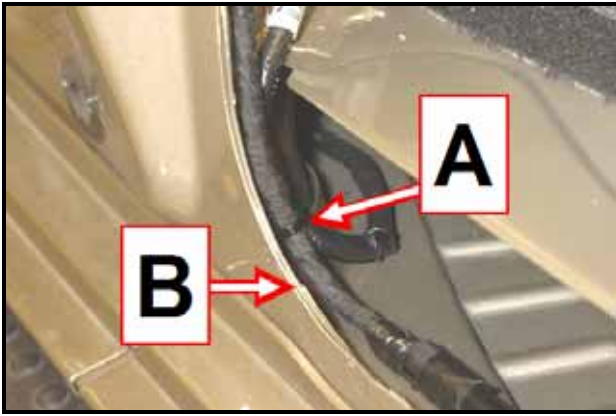

- Position both harnesses together, as shown, where drive unit harness is positioned behind new power sliding door wiring harness
- Carefully bind both harnesses together using tie wrap, part number 7B0 971 818, -A- just above sheet metal division -B-
- Cut off excess tie wrap and position tie wrap lock to the rear of the harnesses



WARNING!

Do not over tighten tie wrap.

Over tightening the tie wrap may cut through the conduit and/or tape.

- Reinstall partially removed sliding door weather seal



Note: Ensure that wiring harnesses are tucked behind the weather seal retaining lip

- Move door manually and verify that lower hinge does not contact weather seal and/or any portion of the wiring harness(es)
- Address opposite side, as necessary
- Go to Section F

Section D – Wiring Harness Repair



Tip: This procedure is shown on the driver side. Perform procedure on both sides of vehicle, if applicable, as outlined by inspection findings in Section A



WARNING!

To avoid serious or fatal injury on vehicles equipped with airbags, disable the supplemental restraint system before attempting any steering wheel, steering column, airbag, occupant classification system, seat belt tensioner, impact sensor, or instrument panel component diagnosis or service. Disconnect and isolate the battery negative cable, then wait two minutes for the system capacitor to discharge before performing further diagnosis or service. This is the only sure way to disable the supplemental restraint system. Failure to take the proper precautions could result in accidental airbag deployment.



WARNING!

Electrostatic discharges can lead to an unintended deployment of the airbag. Therefore the technician must discharge static electricity from the body before working on the airbag system. This is done, for example, by briefly touching the vehicle body or the door striker or pin.



WARNING!

To avoid serious or fatal injury, never strike or drop the side impact sensor, as it can damage the impact sensor or affect its calibration. The side impact sensor enables the system to deploy the side Supplemental Restraint System components.

If an impact sensor is accidentally dropped during service, the sensor must be scrapped and replaced with a new unit. Failure to observe this warning could result in accidental, incomplete, or improper side SRS component deployment.

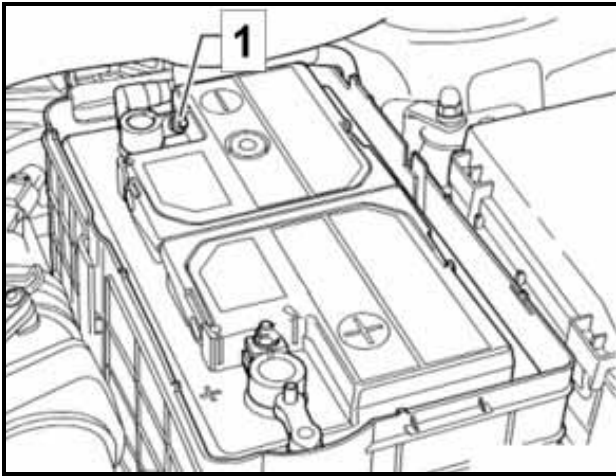

- Place both front seats to the full forward travel position



Tip: This seat position will allow access to all trim panels during repair procedure

- Record all radio presets and comfort settings
 - Open hood
- ⇐ Disconnect battery terminal clamp of Ground (GND) wire -1- from battery Ground (GND) terminal



Note: Use care when removing plastic trim panels when cold

- Remove protective cap and screw at umbrella tray on driver side only



- ⇐ Using trim removal wedge RMCP101 or equivalent, gently pull up on inside edge of sill plate to disengage clips from body and remove front door sill plate -arrow- from vehicle



- ⇐ Using trim removal wedge RMCP101 or equivalent, gently pull up on inside edge of sliding door sill plate -arrow- to disengage clips from body and remove sliding door sill plate from vehicle

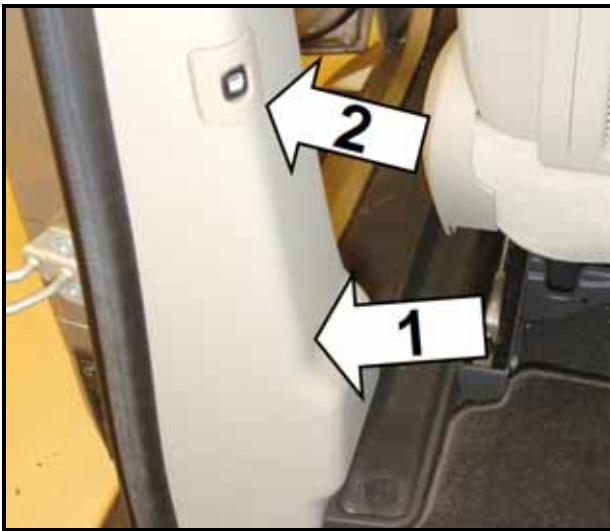

- ⇐ Using trim removal wedge RMCP101 or equivalent, gently remove lower B-pillar trim -arrow 1- and disconnect power sliding door switch -arrow 2- from body wiring harness connector and remove lower B-pillar trim from vehicle

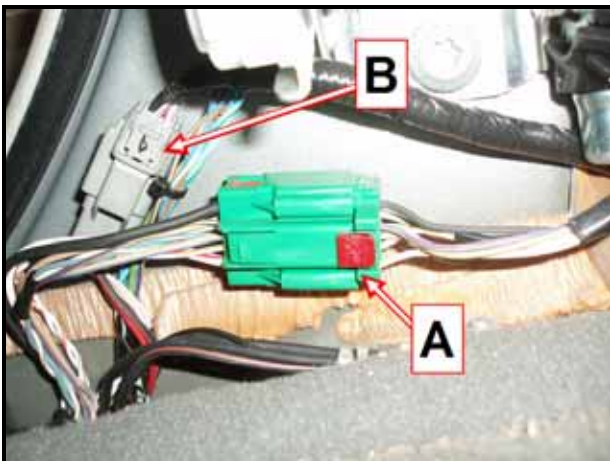

- Disconnect affected chaffed wiring harness connector from main wiring harness connector at lower B-pillar
- ⇐ If power sliding door harness -A- requires repair, continue with procedure
- ⇐ If drive motor wiring harness -B- requires repair, note method used to tape the convolute, and then remove electrical tape from convolute. Slide wires through split in convolute to expose chaffed wire(s), then continue work procedure

Power Sliding Door Harness(es):

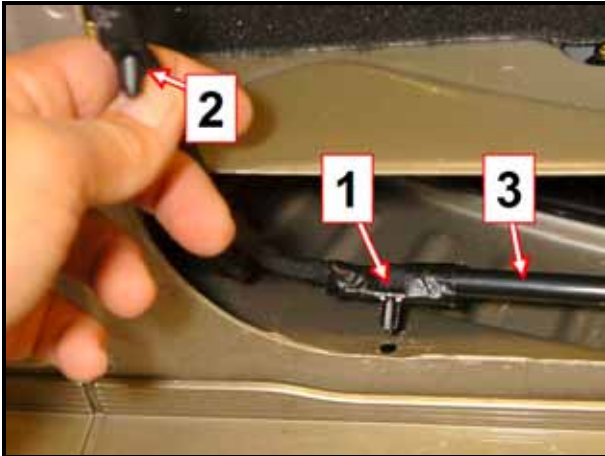

- ⇐ Using pry lever tool 80-200 or equivalent, disengage wiring harness retainers -1- and -2-
- ⇐ Remove wiring harness retainer -1- from front of black plastic split tube -3- of power sliding door wiring harness, noting its original location



- ⇐ Carefully unwrap power sliding door wiring harness, as shown, starting at the front end (in-car position) of the black plastic split tube to expose chaffed wires -arrow-



All Harnesses:

- Select appropriate wire splice band package based on the wire gauge of the chaffed wire
The power sliding door harness has nine 16-gauge wires
The drive motor harness has two 20-gauge and two 12-gauge wires
- Using tool number VAS 1978/3 or equivalent, cut through the damaged wire in the middle of the chaffed area

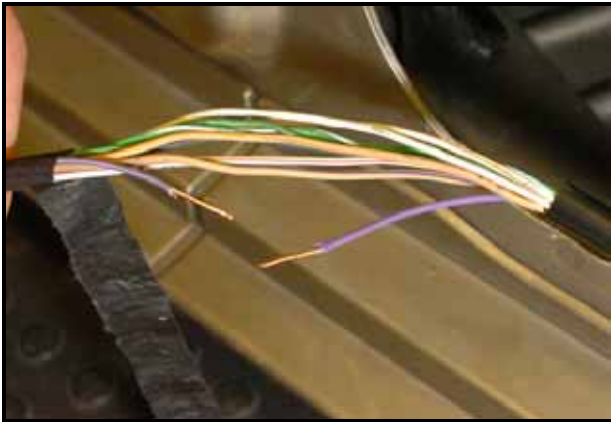



⇐ Remove approximately 13mm (1/2 inch) of insulation from both wires, as shown in picture



 Tip: Right side of crimp tool head 1184-13102 -arrow- must be used for medium sized (16 AWG) band splice, part number 7B0 979 941A

- Load band splice as shown -arrow-

 Tip: This set-up, as shown, is used only to repair the Power Sliding Door Harness (16 AWG) wires

 Note: Using incorrect band splice in the incorrect crimp tool location will result in improper repair



 Tip: Left side of crimp tool head 1184-13102 -arrow- must be used for small sized (20 AWG) band splice, part number 7B0 979 941B

- Load band splice as shown -arrow-

 Tip: This set-up, as shown, is used only to repair the Drive Motor Harness (20 AWG) wires

 Note: Using incorrect band splice in the incorrect crimp tool location will result in improper repair

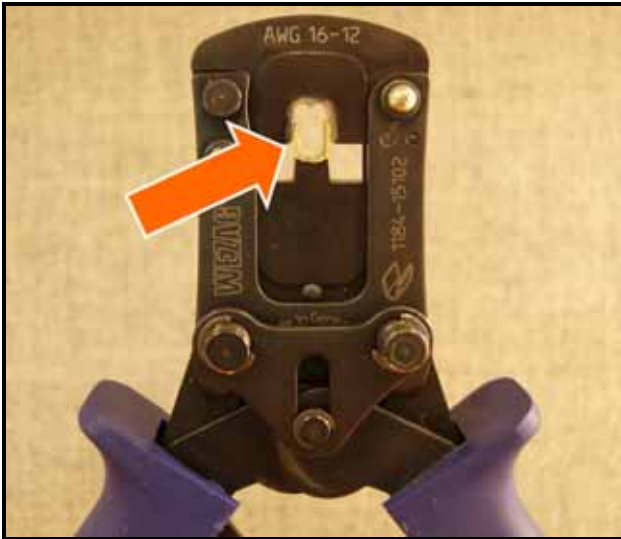

i Tip: The crimp tool head 1184-15102 -arrow- must be used for large sized (12 AWG) band splice, part number 7B0 979 941

- Load band splice as shown -arrow-

i Tip: This set-up as shown is used only to repair the Drive Motor Harness (12 AWG) wires

! Note: Using incorrect band splice in the incorrect crimp tool location will result in improper repair

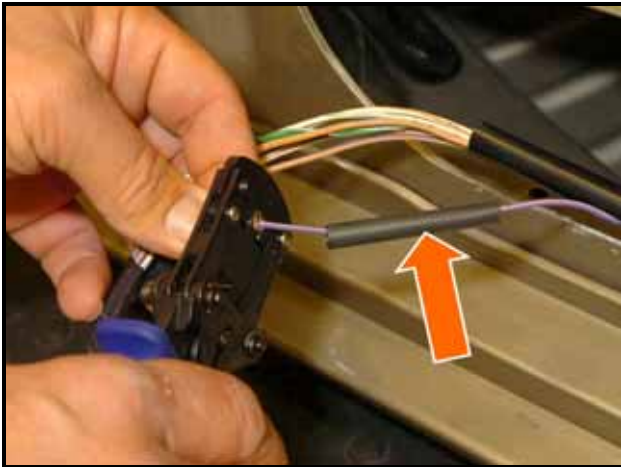

⇐ Install one piece of shrink tube -arrow- over one of the cut wires

- Load tool number VAS 1978/1-2 Crimping Pliers (base tool) with corresponding crimp tool head with correct size band splice (as previously described)
- Insert the two stripped ends of each wire into opposite ends of the band splice pre-loaded in the tool, then properly crimp wires together

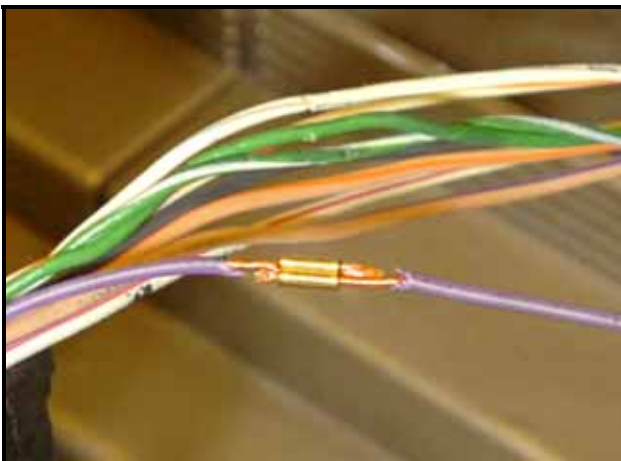

! Note: Wires should overlap each other within the band splice as shown; not butt end-to-end

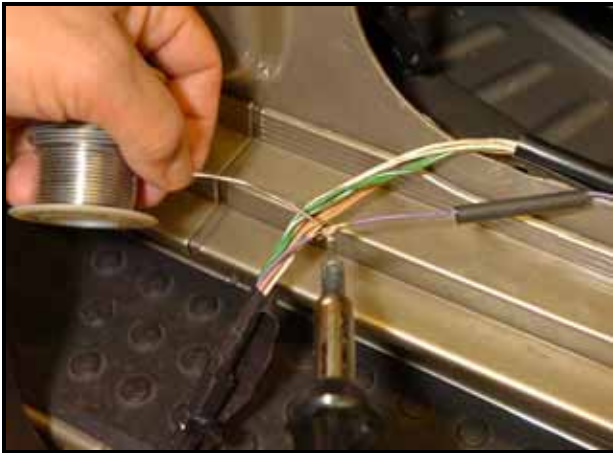

- ⇐ Place tip of a soldering gun below closed end of band splice, as shown, to heat band splice
- ⇐ Once band splice has reach optimum temperature and will melt solder, apply a small amount (1-2 beads) of rosin core solder (shop supply) to the open end of the band splice, as shown, and allow solder to penetrate repaired area

⚠ Note: Use only rosin core solder!

⚠ Note: Do not use acid core solder!

⚠ Note: Do not apply large amounts of solder to the repaired area as solder can wick up the wiring and harden the repair
Repair must remain pliable

ℹ Tip: If your shop does not have a soldering iron, the UTI-100SI Ultratorch tool contained in the VAS 1978B kit comes with a tip for soldering



- ⇐ For heating the shrink tube, set up UTI-100SI Ultratorch tool from VAS 1978B wire harness repair kit, as shown in picture

ℹ Tip: Follow manufacturer instructions provided with the UTI-100SI Ultratorch tool for proper set up, safety and use of the tool

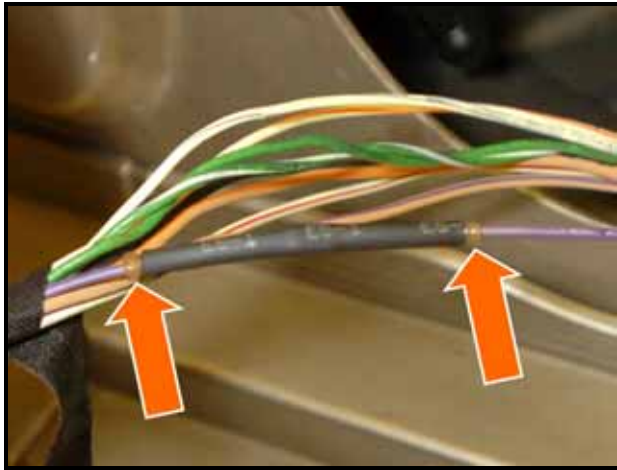

⇐ Center shrink tube over repaired area and use UTI-100SI Ultratorch or equivalent to heat shrink tube until it shrinks around the wire and glue -arrows- protrudes from both ends of the shrink tube, as shown

⚠ Note: Once glue -arrows- protrudes from the ends of the shrink tube, stop application of heat and allow to cool

- Repeat applicable steps in Section D, as necessary, to repair all chafed wires (Reference Repair vs. Replace Summary Chart below)
- Once all chafed wires have been repaired, reposition the wires back into the convolute and/or split tube
- If drive motor harness was repaired, tape drive motor harness with electrical tape, as previously noted
- If power sliding door harness was repaired, tape harness using the cloth tape that was previously unwrapped

Repair vs. Replace Summary Chart			
Harness	Condition	Work	Go to Section
Sliding Door Harness	One or two wires damaged	Repair harness	D
Sliding Door Harness	More than two wires damaged	Replace harness	B
Sliding Door Harness	Chain link disconnected or damaged	Replace harness	B
Drive Motor harness	up to 4 wires damaged	Repair harness	D



⇐ Reposition wiring harness retainer at end of split tube -arrow- and tape wiring harness retainer properly in place with electrical tape

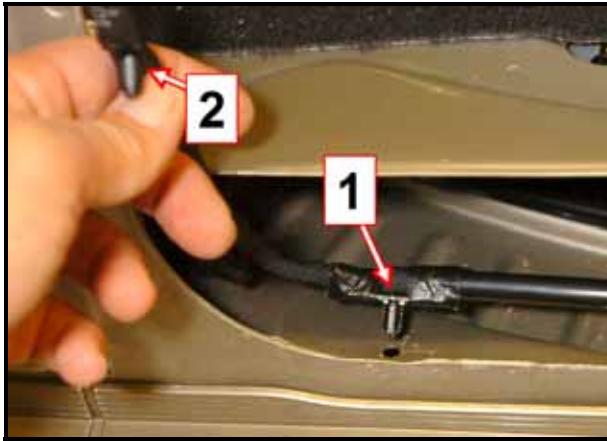

⇐ Reinsert the two lower B-pillar wiring harness retainers -1- and -2- into their retention holes

- If previously disconnected, reconnect drive motor wiring harness connector and/or power sliding door harness connector to their corresponding body harness connector(s) at the base of the B-pillar

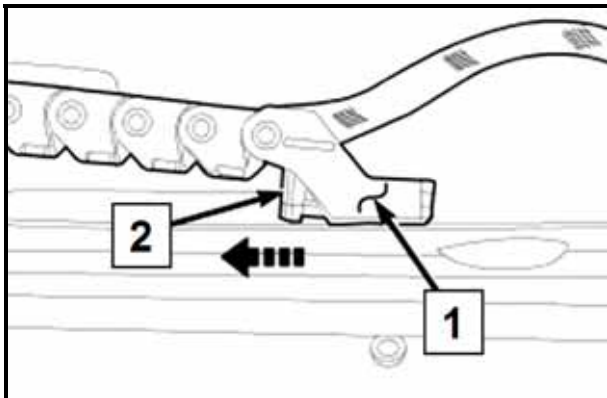

⇐ Disengage locking tab -2- by pulling -in direction of arrow- to release wire harness chain link clip

⇐ Pull chain link -1- down off of the mounting pin on sliding door lower hinge

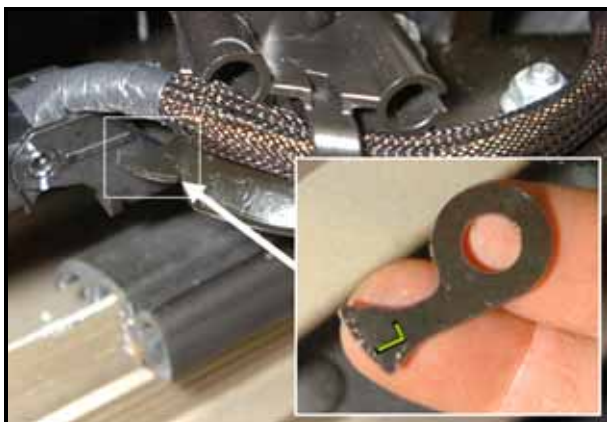

- Install supplied tab/wedge to chain link pivot located on sliding door lower hinge

⚠ Note: The tab/wedge must have the “L” facing up on driver side of vehicle and the “R” facing up on passenger side of vehicle

- While holding tab/wedge in place, snap chain link to lower hinge bracket pivot

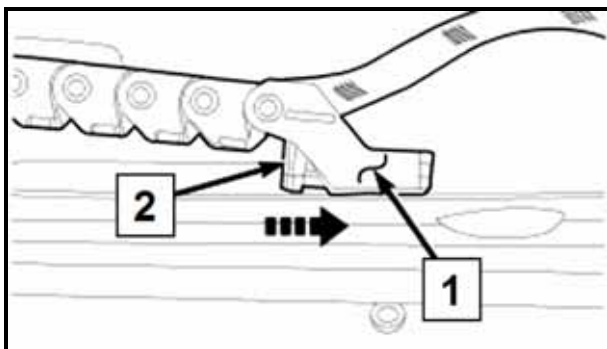

⇐ Lock chain link -1- in place by pushing locking tab -2- rearward -in direction of arrow-



⇐ Reconnect power sliding door switch -arrow 2- to body wiring harness connector and reinstall lower B-pillar trim -arrow 1-



⇐ Reinstall sliding door sill plate -arrow-



⇐ Reinstall front door sill plate -arrow-



- Reinstall screw and protective cap for umbrella tray on driver side only

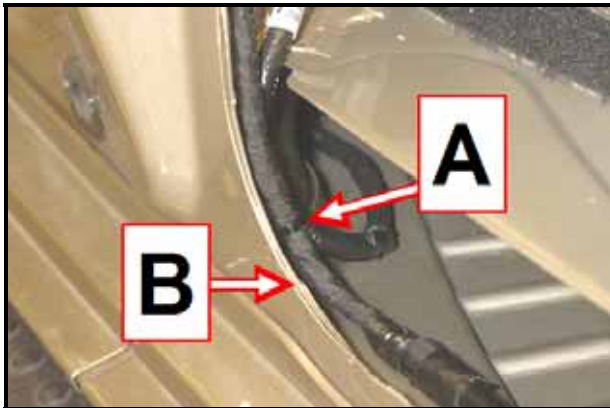

- Position both harnesses together, as shown, where drive unit harness is positioned behind new power sliding door wiring harness
- ⇐ Carefully bind both harnesses together using tie wrap, part number 7B0 971 818, -A- just above sheet metal division -B-
- Cut off excess tie wrap and position tie wrap lock to the rear of the harnesses

⚠ WARNING!
Do not over tighten tie wrap.
Over tightening the tie wrap may cut through the conduit and/or tape.

- Reinstall the partially removed sliding door weather seal

ⓘ Note: Ensure that wiring harnesses are tucked behind weather seal retaining lip

- Move door manually and verify that lower hinge does not contact weather seal and/or any portion of wiring harnesses
- Address opposite side, as needed
- For restoring power, go to Section E

Section E – Restoring Power

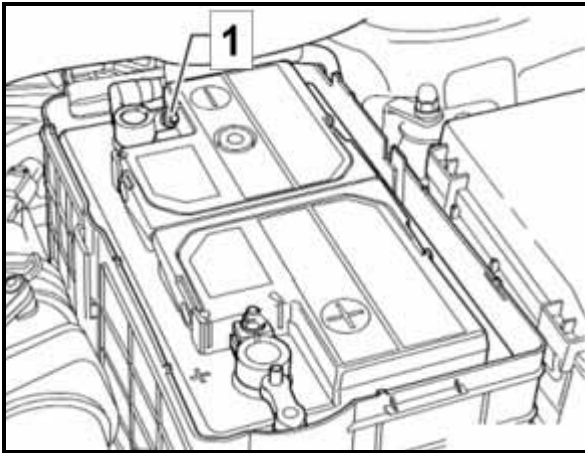

WARNING!

Ignition must be on when connecting battery. If pyrotechnic components (e.g., airbag, belt tensioner) are not repaired correctly, they may deploy unintentionally after connecting the battery.



WARNING!

Ensure that no persons are in the vehicle.

- Switch on ignition
- ⇐ Connect battery terminal clamp of Ground (GND) wire -1- to battery Ground (GND) terminal and tighten nut to 5Nm



Note: Once battery has been connected, review and perform the following information as applicable

- If vehicle is equipped with electronic stability program, once the battery is reconnected, the steering angle sensor in the clockspring needs to be calibrated. The SAS requires calibration anytime the battery or an ABS/ESP component has been disconnected for any length of time. If the SAS is not calibrated following battery reconnection, the ESP/BAS indicator lamp is illuminated following five ignition cycles indicating the need for calibration.
- To calibrate, perform the following:
 - Start engine
 - Center the steering wheel
 - Turn steering wheel all the way to the left until the internal stop in the steering gear is met, then turn the wheel all the way to the right until the opposite internal stop in the steering gear is met
 - Center the steering wheel
 - Stop engine
- Return both front seats to their original position
- Reset all radio presets and comfort settings
- Go to Section F

Campaign Completion	
SAGA CODE:	
DLR #:	
REPAIR DATE:	
	CAMP 010 000

Section F – Applying the Campaign Label

- If necessary, open hood
- ← Fill out and affix Campaign Completion label, part number CAMP 010 000, on cleaned surface, next to the vehicle emission control information label
- Close hood

WORK IS COMPLETE

Section G – Part Return

USA Dealers

The SAGA system **will** generate a part request bar code for this campaign. An electronic FedEx shipping label will be generated in the Warranty Parts Shipping Portal (WPSP) for 97S8 campaign parts that are to be returned under this campaign.

Include all pages of claim documentation with the wiring harness(es); use the free FedEx shipping label from the WPSP to ship the item(s) to Volkswagen at:

*VW Warranty Parts Return Center
3800 Hamlin Road
Auburn Hills, MI 48399*

Claims will be debited for parts not received within 14 days from the date of the part return request.

IMPORTANT!

When returning parts under this action, do not include any other items you need to send to the Warranty Parts Return Center with your shipment. Unrelated items shipped with returned wiring harnesses will not be acknowledged or returned.

CANADA Dealers

The SAGA system **will** generate a bar code and part return sheets for the 97S8 campaign.

Include all pages of the part return sheets with wiring harness(es) when shipping the items to Volkswagen.

*Follow the normal parts return process.
Please include the campaign identification:
97S8/T7 Parts Return*

IMPORTANT!

When returning parts under this action, do not include any other items you need to send to the Warranty Parts Return Center with your shipment. Unrelated items shipped with returned wiring harnesses will not be acknowledged or returned.