



Service Bulletin No. 345

MODEL D Series Coaches	TYPE Field Change Program	SECTION/GROUP 15-Wheel	DATE
SUBJECT ARVINMERITOR WHEEL ADAPTER CAPSCREWS ON UWE AXLES			
CONDITIONS			

Ref. ARVINMERITOR NHTSA Recall No.: 10E-014

Ref. MCI NHTSA Recall No.: 10V-199

Ref. Transport Canada Recall No.: TC 2010-153

Customer Complaint:

ArvinMeritor has reported to Motor Coach Industries (MCI) that a defect which relates to motor vehicle safety exists in wheel end adapter capscrews on certain front steer and rear tag axles. The suspect axles may have had improper amount of torque applied to the hub/rotor/wheel adapter capscrews during the assembly process. A reduced capscrew torque potentially reduces the clamp force which, in turn, could lead to a vibration loosening concern. The potential may also exist whereas the operational loads could be greater than the capscrew clamping forces, which can lead to possible capscrew fatigue issues. Complete loss of clamp load could result in a wheel off condition.

Cause:

ArvinMeritor reports that the suspect front and tag axles may have had improper amount of torque applied to the wheel adapter during the assembly process.

Corrective Action:

MCI and ArvinMeritor recommend that the front and tag axle wheel adapter capscrews on affected coaches be inspected and replaced as recommended as soon as feasible in order to eliminate any unexpected wheel conditions. Inspection of the adaptor plate capscrew torque will determine if bolt replacement is required during the torque validation of the bolts. Additional details for inspection and replacement procedures are described in this bulletin and in the ArvinMeritor Technical Publication TP-10110 with MCI Coach-UWE Bolt Torque-Inspection Chart attached to this bulletin.

The MCI coach models that need to be inspected for this defect are the following:

- D4000, D4000ISTV and D4005 models (front axle only) with the following VIN's (inclusive): 59196 to 59419
- D4500 and D4505 models (front and tag axle) with the following VIN's (inclusive): 59196 to 59419
- E4500 model (front and tag axle) with the following VIN's (inclusive): 65501 to 65519
- J4500 and J4500C (front and tag axle) model with the following VIN's (inclusive): 65487 to 65597

Accordingly, MCI is instituting a field change program to inspect and replace, if necessary, the ArvinMeritor front and tag axle wheel adapter capscrews in all of the coaches listed above. This bulletin describes the procedure to inspect and replace, if necessary, the ArvinMeritor front and tag axle wheel adapter capscrews in the D series coaches.

MCI's Service Bulletin 346 describes the procedure to inspect and replace, if necessary, the ArvinMeritor front and tag axle wheel adapter capscrews in E and J models.

Parts

<u>Qty.</u>	<u>New P/N</u>	<u>Description</u>
1	15-02-1047	Capscrew
1	15-02-1060	Kit, Wheel Adapter, UWE Axles
		<i>Kit Contents Are:</i>
12		Capscrew
12		Washer
a/r		Torque Seal

Service Procedure:



Read this entire procedure before beginning work.

Use Safe Shop Practices At All Times.

1. Open the engine doors. Position the ENGINE RUN and ENGINE START switches on the engine compartment remote control box to the OFF position. Check both sides of the tires.
2. Locate the twelve (12) wheel adapter capscrews on the front axle (refer to Figure 1).

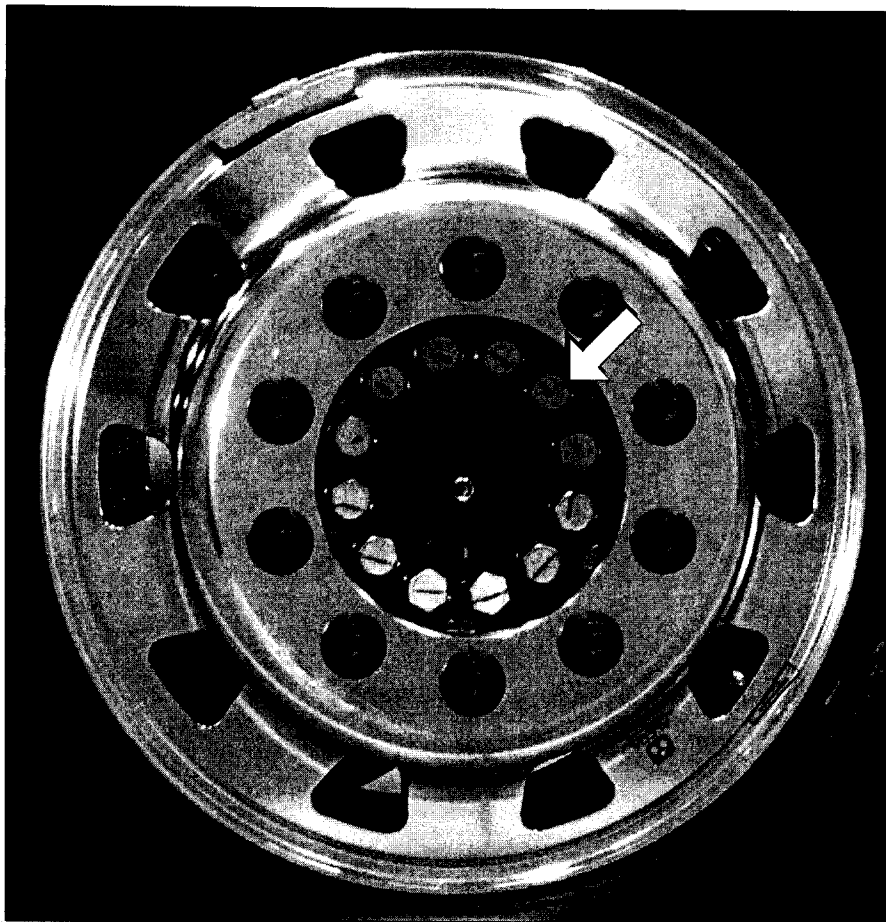

Figure 1.

3. Using a torque wrench with a dial indicator, check and record the torque value of all twelve (12) wheel adapter capscrews on the MCI Coach–UWE Bolt Torque–Inspection Chart.

NOTICE

Upon inspection, if one (1) capscrew is found at a torque less than 150 ft-lbs, the capscrew needs to be replaced with p/n 15-02-1047, and properly torqued. Discard existing capscrew.

Upon inspection, if two (2) or more capscrews are found at a torque less than 150 ft-lbs, all twelve (12) capscrews need to be replaced with Kit p/n 15-02-1060, and properly torqued.

4. Using a torque wrench, tighten all twelve (12) capscrews to 250 to 300 ft–lbs, in a star pattern. Apply torque seal from the face of the capscrew to the face of the wheel adapter.
5. Proceed to the opposite side of the front axle. Repeat Steps 2. to 4. in their entirety.
6. Proceed to the tag axle. Repeat Steps 2. to 4. in their entirety to both sides of the tag axle.
7. Position the ENGINE RUN and ENGINE START switches on the engine compartment remote control box to the ON position. Close the engine doors.

Procedure complete.

Mail or fax the completed warranty claim form and the MCI Coach–UWE Bolt Torque–Inspection Chart to MCI's warranty department, or photo copy and mail to:

MCI Fleet Support
Attn: Warranty Department
7001 Universal Coach Drive
Louisville, KY 40258
Fax Number 1-800-360-8886

to receive credit for the hours used to complete this task. Contact the MCI Fleet Support Technical Center at 1-800-241-2947 for any further information.

Field Change Program Conditions:

The parts required for this change will be supplied without charge.

A labor allowance of 0.25 hour will be granted for each wheel end inspected on the front axle only, for the procedure of inspecting the specified part in this bulletin on D4000, D4000ISTV and D4005 model coaches.

A labor allowance of 0.25 hour will be granted for each wheel end inspected on the front and tag axle, for the procedure of inspecting the specified part in this bulletin on D4500 and D4505 model coaches.

An additional labor allowance of 0.1 hour will be granted, for the procedure of replacing 1–2 wheel adapter capscrews on D series coaches. A labor allowance of 0.6 hour will be granted, for the procedure of replacing all 12 wheel adapter capscrews, if necessary, on D series coaches.

This labor allowance will be credited to your MCI Fleet Support Parts Account on receipt of the MCI Coach–UWE Bolt Torque–Inspection Chart and a "Warranty Claim Form" as detailed in your Owner Warranty manual to MCI's Warranty department.

Motor Coach apologizes for any inconvenience resulting from this campaign, but urges you to have your affected coaches inspected and repaired as necessary as soon as possible.

Sincerely,

Motor Coach Industries
U.S. and Canadian Service Departments.



MOTOR COACH
INDUSTRIES

MCI FIELD CAMPAIGN VERIFICATION

CONTACT INFORMATION	
CUSTOMER NAME: _____ (PLEASE PRINT)	
FCP INFORMATION – ONE FORM PER UNIT	
FCP#:	
UNIT#:	DATE COMPLETED __ / __ / __
MILEAGE:	
<u>IMPORTANT:</u> VERIFICATION FORM TO BE RETURNED UP ON COMPLETION OF THE F.C.P.	
SUBMITTED BY: (Please Print) _____ DATE __ / __ / __	
SIGNATURE: _____	
COMMENTS:	

FAX TO: 1-502-318-8183

MAILING ADDRESS:

MOTOR COACH INDUSTRIES
ATTN: WARRANTY DEPT.
7001 UNIVERSAL COACH DRIVE
LOUISVILLE, KY 40258

MERITOR®
an **ArvinMeritor** brand

Technical Bulletin

Inspect for Under-Tightened Hub/Rotor/Adapter Plate Bolts on Meritor Front Non-Drive Steer Axles and Tag Axles Equipped with Unitized Wheel Ends Installed on Motor Coach Industries (MCI) Coaches

All Meritor FH941 and FH946 Front Non-Drive Steer
Axles, and MC14 and MC16 Series Tag Axles

Hazard Alert Messages

Read and observe all Warning and Caution hazard alert messages in this publication. They provide information that can help prevent serious personal injury, damage to components, or both.

WARNING

To prevent serious eye injury, always wear safe eye protection when you perform vehicle maintenance or service.

Park the vehicle on a level surface. Block the wheels to prevent the vehicle from moving. Support the vehicle with safety stands. Do not work under a vehicle only supported by jacks. Jacks can slip or fall over. Serious personal injury and damage to components can result.

CAUTION

A unitized wheel end is sealed and greased for life and does not require lubrication. If you disassemble, or attempt to repair or lubricate a unitized wheel end assembly, the Meritor warranty will be void, and damage to components can result.

A unitized wheel end is not adjustable. Do not attempt to set or adjust end play. Damage to components can result.

How to Obtain Additional Maintenance and Service Information

Refer to Maintenance Manual MM-0409, Wheel-End Components; Maintenance Manual 23, Bus and Coach Front Axles; and Maintenance Manual MM-0467, DiscPlus™ EX225 Air Disc Brake. To obtain these publications, visit Literature on Demand at arvinmeritor.com.

How to Obtain Hub/Rotor/Adapter Plate Bolts (ArvinMeritor Part Number 10X1711)

Contact the original equipment manufacturer (OEM) or the ArvinMeritor OnTrac™ Performance Plus Call Center (phone: 866-668-7221/Fax: 248-435-5580/Email ontrac@arvinmeritor.com).

Inspection and Service Procedures

Check Hub/Rotor/Adapter Plate Bolt Torque on the Unitized Wheel Ends

1. Wear safe eye protection.
2. Park the vehicle on a level surface. Block the wheels to prevent the vehicle from moving.

WARNING

When you install new hub/rotor/adapter plate bolts (ArvinMeritor part number 10X1711) as instructed in this technical bulletin, discard the old bolts. Do not reuse the bolts. A reused bolt will not tighten correctly, which can cause the wheel to loosen and separate from the vehicle. Serious personal injury and damage to components can result.

3. Use a torque wrench with a dial indicator to check hub/rotor/adapter plate bolt torque on all 12 bolts on each unitized wheel end. The bolt torque must not be less than 150 lb-ft (203 N•m). Record the torque on the Inspection Sheet included in this bulletin. 
- If hub/rotor/adapter plate bolt torque on any one of the 12 bolts on each unitized wheel end is less than 150 lb-ft (203 N•m): Replace the bolt using ArvinMeritor part number 10X1711. Discard the bolts that were removed. Do not reuse old bolts. Record the bolt replacement on the Inspection Sheet included in this bulletin.

- If any two or more bolts in the same bolt circle on a wheel end are less than 150 lb-ft (203 N•m): Replace all 12 bolts on the unitized wheel end using ArvinMeritor part number 10X1711. Remove, replace and tighten each bolt one at a time to maintain the correct clamp load on the wheel end. Discard the bolts that were removed. Do not reuse old bolts. Record the bolt replacement and torque in the Inspection Sheet included in this bulletin.

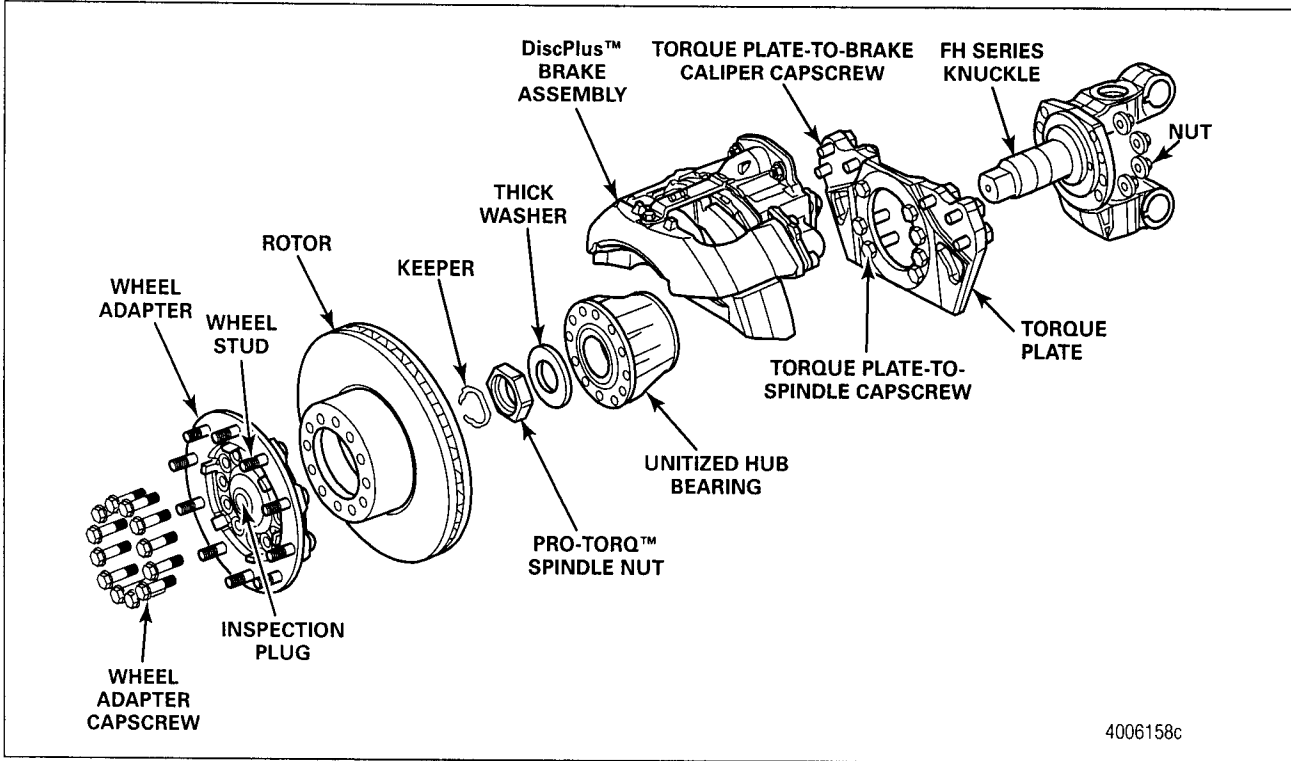

4. Use a click torque wrench to tighten all remaining bolts and any replacement bolts in a star pattern to 275 ± 25 lb-ft (373 ± 34 N•m). Record the torque on the Inspection Sheet included in this bulletin. When you have tightened all of the bolts, recheck the torque of all 12 bolts in a star pattern. 
5. Mark a stripe on all of the tightened bolts. Use a different color than the color already used.

MCI Coach — UWE Bolt Torque — Inspection Chart

VIN:	In-Service Date:	Repair Date:	Mileage:
Torque Wrench Dial Indicator – Calibration # Torque Click Wrench – Calibration #		Inspect By:	
Right Front Non-Drive Steer Wheel End Axle Serial Number:		Left Front Non-Drive Steer Wheel End	
Bolt #	Original Torque	Bolt Replaced (Yes/No)	New Torque
1			
2			
3			
4			
5			
6			
7			
8			
9			
10			
11			
12			
Comments:		Comments:	

Bolt #	Right Tag Wheel End Axle Serial Number:			Left Tag Axle Wheel End		
	Original Torque	Bolt Replaced (Yes/No)	New Torque	Original Torque	Bolt Replaced (Yes/No)	New Torque
1						
2						
3						
4						
5						
6						
7						
8						
9						
10						
11						
12						
	Comments:			Comments:		

ArvinMeritor™

Meritor Heavy Vehicle Systems, LLC
2135 West Maple Road
Troy, MI 48084 USA
800-535-5560
arvinmeritor.com

Information contained in this publication was in effect at the time the publication was approved for printing and is subject to change without notice or liability. Meritor Heavy Vehicle Systems, LLC, reserves the right to revise the information presented or to discontinue the production of parts described at any time.

Copyright 2010
ArvinMeritor, Inc.
All Rights Reserved

Printed in USA

TP-10110
Issued 05-10
(16579)



Service Bulletin No. 346

MODEL E / J Series Coaches	TYPE Field Change Program	SECTION/GROUP 15-Wheel	DATE
SUBJECT ARVINMERITOR WHEEL ADAPTER CAPSCREWS ON UWE AXLES			
CONDITIONS			

Ref. ARVINMERITOR NHTSA Recall No.: 10E-014

Ref. MCI NHTSA Recall No.: 10V-199

Ref. Transport Canada Recall No.: TC 2010-153

Customer Complaint:

ArvinMeritor has reported to Motor Coach Industries (MCI) that a defect which relates to motor vehicle safety exists in wheel end adapter capscrews on certain front steer and rear tag axles. The suspect axles may have had improper amount of torque applied to the hub/rotor/wheel adapter capscrews during the assembly process. A reduced capscrew torque potentially reduces the clamp force which, in turn, could lead to a vibration loosening concern. The potential may also exist whereas the operational loads could be greater than the capscrew clamping forces, which can lead to possible capscrew fatigue issues. Complete loss of clamp load could result in a wheel off condition.

Cause:

ArvinMeritor reports that the suspect front and tag axles may have had improper amount of torque applied to the wheel adapter during the assembly process.

Corrective Action:

MCI and ArvinMeritor recommend that the front and tag axle wheel adapter capscrews on affected coaches be inspected and replaced as recommended as soon as feasible in order to eliminate any unexpected wheel conditions. Inspection of the adaptor plate capscrew torque will determine if bolt replacement is required during the torque validation of the bolts. Additional details for inspection and replacement procedures are described in this bulletin and in the ArvinMeritor Technical Publication TP-10110 with MCI Coach-UWE Bolt Torque-Inspection Chart attached to this bulletin.

The MCI coach models that need to be inspected for this defect are the following:

- D4000, D4000ISTV and D4005 models (front axle only) with the following VIN's (inclusive): 59196 to 59419
- D4500 and D4505 models (front and tag axle) with the following VIN's (inclusive): 59196 to 59419
- E4500 model (front and tag axle) with the following VIN's (inclusive): 65501 to 65519
- J4500 and J4500C (front and tag axle) model with the following VIN's (inclusive): 65487 to 65597

Accordingly, MCI is instituting a field change program to inspect and replace, if necessary, the ArvinMeritor front and tag axle wheel adapter capscrews in all of the coaches listed above. This bulletin describes the procedure to inspect and replace, if necessary, the ArvinMeritor front and tag axle wheel adapter capscrews in the E / J series coaches.

MCI's Service Bulletin 345 describes the procedure to inspect and replace, if necessary, the ArvinMeritor front and tag axle wheel adapter capscrews in D models.

Parts

Qty.	New P/N	Description
1	15-02-1047	Capscrew
1	15-02-1060	Kit, Wheel Adapter, UWE Axles
		<i>Kit Contents Are:</i>
12		Capscrew
12		Washer
a/r		Torque Seal

Service Procedure:



Read this entire procedure before beginning work.

Use Safe Shop Practices At All Times.

1. Open the engine door. Position the ENGINE RUN and ENGINE START switches on the engine compartment remote control box to the OFF position. Chock both sides of the tires.

NOTICE

If coach is not equipped with hub covers (refer to Figure 1 or 2), proceed to Step 4.

If coach is equipped with hub covers, proceed to Step 2. or Step 3. , as applicable to coach configuration.

Failure to follow the hub cover removal procedure in Step 2. may result in damage to the hub cover.

2. Locate the one piece hub cover on the front axle wheel end. Visually locate the notch on the side of the hub cover. Insert the hub cover removal tool, reference p/n 15-01-1216, into the notch on the side of the hub cover (refer to Figure 1). Using the removal tool, in a rotating action carefully separate the hub cover away from the wheel face. Place aside to be re-installed at a later step in this procedure.

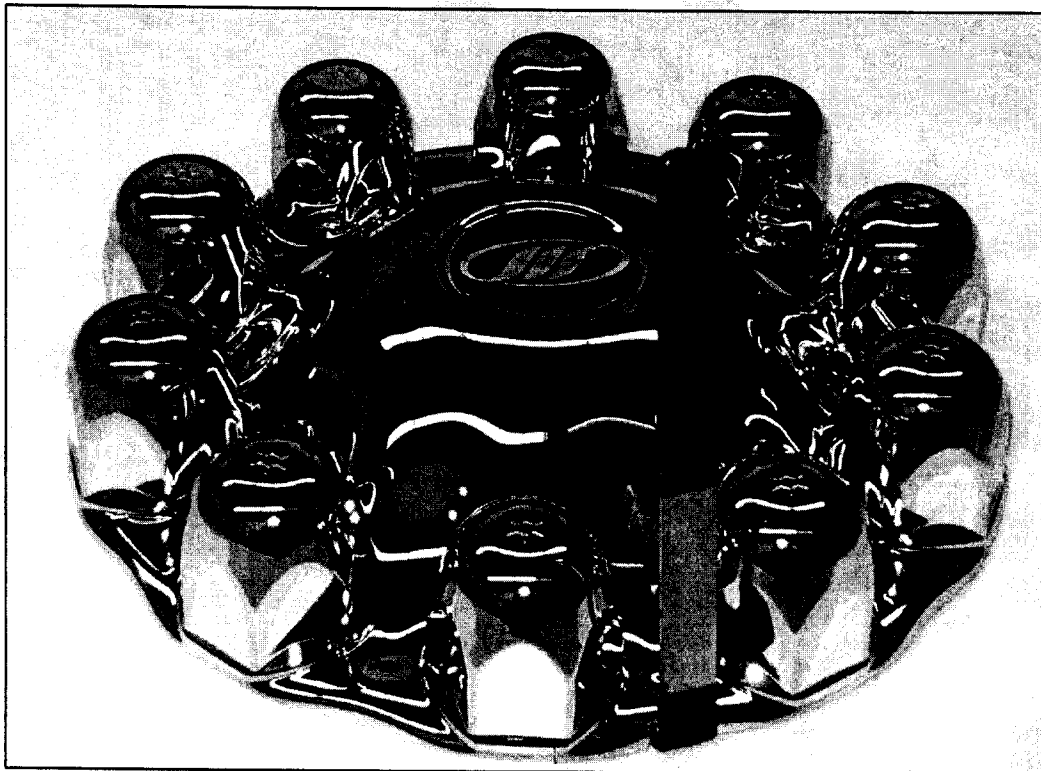

Figure 1. Front / tag axle one-piece hub cover with removal tool.

NOTICE

If coach is not equipped with hub covers (refer to Figure 1 or 2), proceed to Step 4.

Failure to follow the hub cover removal procedure in Step 3. may result in damage to the hub cover.

3. Locate the 11-piece hub cover on the front axle wheel end. Insert the removal tool on a lug nut cover (refer to Figure 1). Using the removal tool, in a back and forth action carefully separate the lug nut cover from the lug nut. Repeat to remaining nine (9) lug nut covers until the center hub cover is released. Place aside to be re-installed at a later step in this procedure.

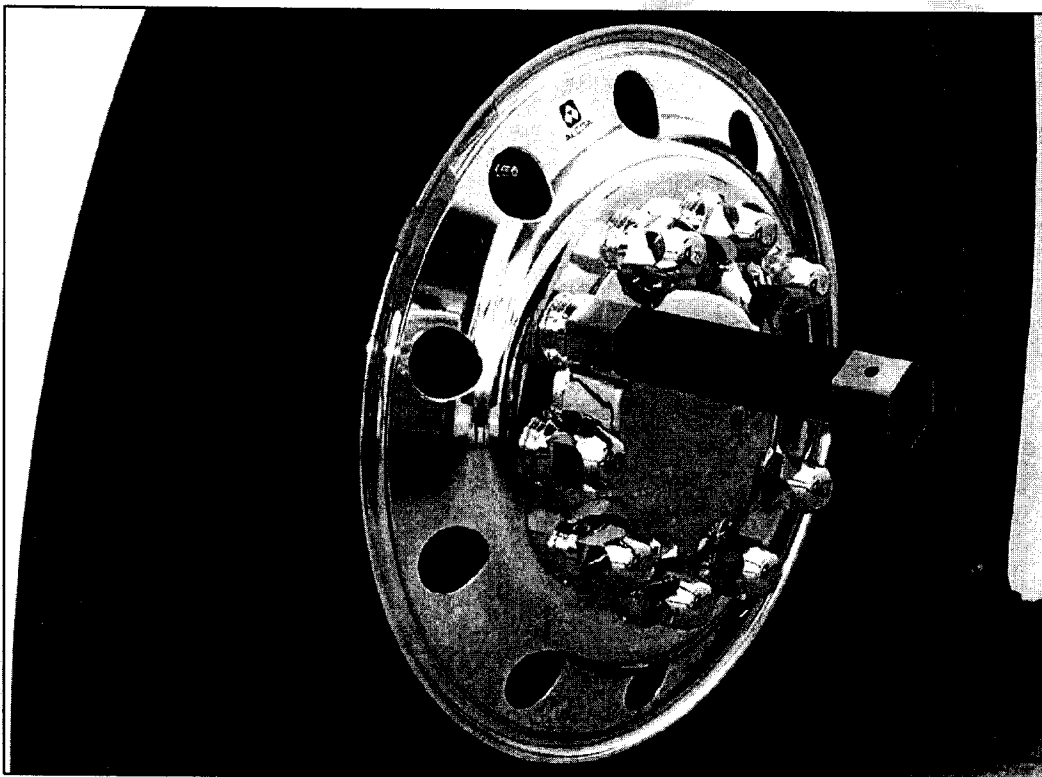

Figure 2. Front / tag axle 11-piece hub cover with removal tool.

4. Locate the twelve (12) wheel adapter capscrews on the front axle (refer to Figure 3).

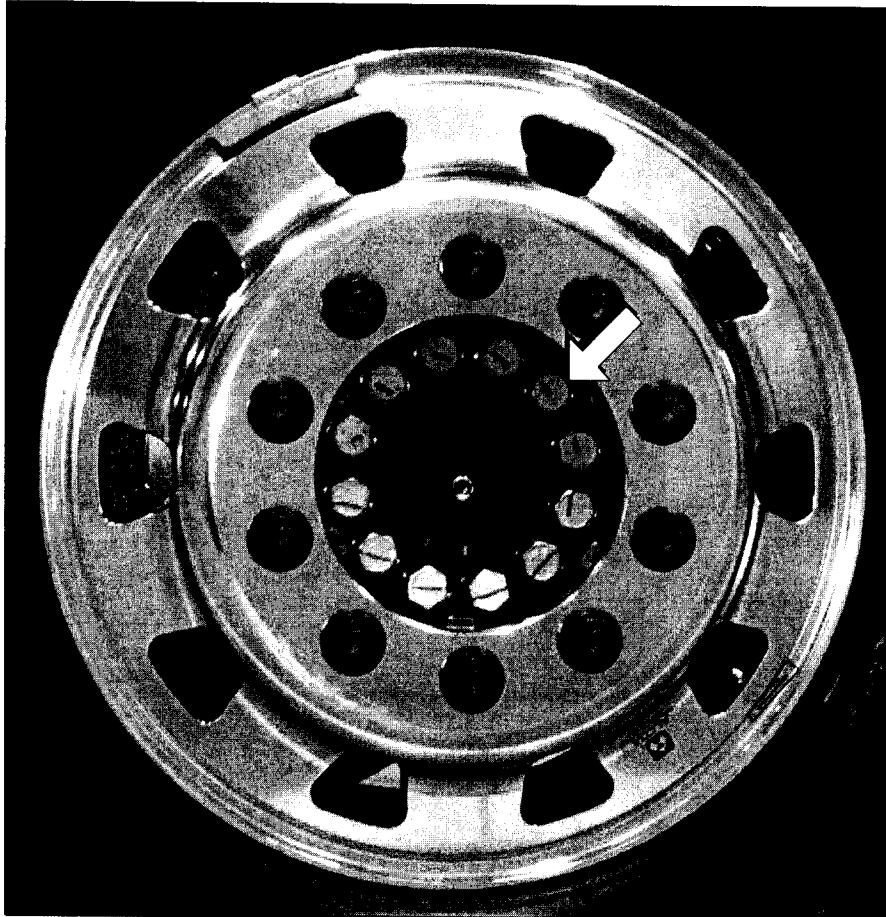

Figure 3.

5. Using a torque wrench with a dial indicator, check and record the torque value of all twelve (12) wheel adapter capscrews on the MCI Coach-UWE Bolt Torque-Inspection Chart.

NOTICE

Upon inspection, if one (1) capscrew is found at a torque less than 150 ft-lbs, the capscrew needs to be replaced with p/n 15-02-1047, and properly torqued. Discard existing capscrew.

Upon inspection, if two (2) or more capscrews are found at a torque less than 150 ft-lbs, all twelve (12) capscrews need to be replaced with Kit p/n 15-02-1060, and properly torqued.

6. Using a torque wrench, tighten all twelve (12) capscrews to 250 to 300 ft-lbs, in a star pattern. Apply torque seal from the face of the capscrew to the face of the wheel adapter.
7. Proceed to the opposite side of the front axle. Repeat Steps 4. to 6. in their entirety.
8. Proceed to the tag axle. Repeat Steps 4. to 6. in their entirety to both sides of the tag axle.
9. If coach is so equipped, use a short handle rubber mallet and controlled force on the lug nut feature in a counter-clockwise patten to re-install the hub covers. When hub cover is fully installed, there is no gap between the hub cover and the wheel face.
10. Position the ENGINE RUN and ENGINE START switches on the engine compartment remote control box to the ON position. Close the engine door.

Procedure complete.

Mail or fax the completed warranty claim form and the MCI Coach–UWE Bolt Torque–Inspection Chart to MCI's warranty department, or photo copy and mail to:

MCI Fleet Support
Attn: Warranty Department
7001 Universal Coach Drive
Louisville, KY 40258
Fax Number 1-800-360-8886

to receive credit for the hours used to complete this task. Contact the MCI Fleet Support Technical Center at 1-800-241-2947 for any further information.

Field Change Program Conditions:

The parts required for this change will be supplied without charge.

A labor allowance of 0.25 hours will be granted for each wheel end inspected on the front and tag axle, for the procedure of inspecting the specified part in this bulletin on E / J series coaches.

An additional labor allowance of 0.1 hour will be granted, for the procedure of replacing 1–2 wheel adapter capscrews on E / J series coaches. A labor allowance of 0.6 hour will be granted, for the procedure of replacing all 12 wheel adapter capscrews, if necessary, on E / J series coaches.

This labor allowance will be credited to your MCI Fleet Support Parts Account on receipt of the MCI Coach–UWE Bolt Torque–Inspection Chart and a "Warranty Claim Form" as detailed in your Owner Warranty manual to MCI's Warranty department.

Motor Coach apologizes for any inconvenience resulting from this campaign, but urges you to have your affected coaches inspected and repaired as necessary as soon as possible.

Sincerely,

Motor Coach Industries
U.S. and Canadian Service Departments.



MOTOR COACH
INDUSTRIES

MCI FIELD CAMPAIGN VERIFICATION

CONTACT INFORMATION	
CUSTOMER NAME: _____ (PLEASE PRINT)	
FCP INFORMATION – ONE FORM PER UNIT	
FCP#:	
UNIT#:	DATE COMPLETED __ / __ / __
MILEAGE:	
<u>IMPORTANT:</u> VERIFICATION FORM TO BE RETURNED UP ON COMPLETION OF THE F.C.P.	
SUBMITTED BY: (Please Print) _____ DATE __ / __ / __	
SIGNATURE: _____	
COMMENTS:	

FAX TO: 1-502-318-8183

MAILING ADDRESS:

MOTOR COACH INDUSTRIES
ATTN: WARRANTY DEPT.
7001 UNIVERSAL COACH DRIVE
LOUISVILLE, KY 40258

MERITOR[®]
an **ArvinMeritor** brand

Technical Bulletin

Inspect for Under-Tightened Hub/Rotor/Adapter Plate Bolts on Meritor Front Non-Drive Steer Axles and Tag Axles Equipped with Unitized Wheel Ends Installed on Motor Coach Industries (MCI) Coaches

All Meritor FH941 and FH946 Front Non-Drive Steer
Axles, and MC14 and MC16 Series Tag Axles

Hazard Alert Messages

Read and observe all Warning and Caution hazard alert messages in this publication. They provide information that can help prevent serious personal injury, damage to components, or both.

WARNING

To prevent serious eye injury, always wear safe eye protection when you perform vehicle maintenance or service.

Park the vehicle on a level surface. Block the wheels to prevent the vehicle from moving. Support the vehicle with safety stands. Do not work under a vehicle only supported by jacks. Jacks can slip or fall over. Serious personal injury and damage to components can result.

CAUTION

A unitized wheel end is sealed and greased for life and does not require lubrication. If you disassemble, or attempt to repair or lubricate a unitized wheel end assembly, the Meritor warranty will be void, and damage to components can result.

A unitized wheel end is not adjustable. Do not attempt to set or adjust end play. Damage to components can result.

How to Obtain Additional Maintenance and Service Information

Refer to Maintenance Manual MM-0409, Wheel-End Components; Maintenance Manual 23, Bus and Coach Front Axles; and Maintenance Manual MM-0467, DiscPlus™ EX225 Air Disc Brake. To obtain these publications, visit Literature on Demand at arvinmeritor.com.

How to Obtain Hub/Rotor/Adapter Plate Bolts (ArvinMeritor Part Number 10X1711)

Contact the original equipment manufacturer (OEM) or the ArvinMeritor OnTrac™ Performance Plus Call Center (phone: 866-668-7221/Fax: 248-435-5580/Email ontrac@arvinmeritor.com).

Inspection and Service Procedures

Check Hub/Rotor/Adapter Plate Bolt Torque on the Unitized Wheel Ends

1. Wear safe eye protection.
2. Park the vehicle on a level surface. Block the wheels to prevent the vehicle from moving.

WARNING

When you install new hub/rotor/adapter plate bolts (ArvinMeritor part number 10X1711) as instructed in this technical bulletin, discard the old bolts. Do not reuse the bolts. A reused bolt will not tighten correctly, which can cause the wheel to loosen and separate from the vehicle. Serious personal injury and damage to components can result.

3. Use a torque wrench with a dial indicator to check hub/rotor/adapter plate bolt torque on all 12 bolts on each unitized wheel end. The bolt torque must not be less than 150 lb-ft (203 N•m). Record the torque on the Inspection Sheet included in this bulletin. 
- If hub/rotor/adapter plate bolt torque on any one of the 12 bolts on each unitized wheel end is less than 150 lb-ft (203 N•m): Replace the bolt using ArvinMeritor part number 10X1711. Discard the bolts that were removed. Do not reuse old bolts. Record the bolt replacement on the Inspection Sheet included in this bulletin.

- If any two or more bolts in the same bolt circle on a wheel end are less than 150 lb-ft (203 N•m): Replace all 12 bolts on the untized wheel end using ArvinMeritor part number 10X1711. Remove, replace and tighten each bolt one at a time to maintain the correct clamp load on the wheel end. Discard the bolts that were removed. Do not reuse old bolts. Record the bolt replacement and torque in the Inspection Sheet included in this bulletin.

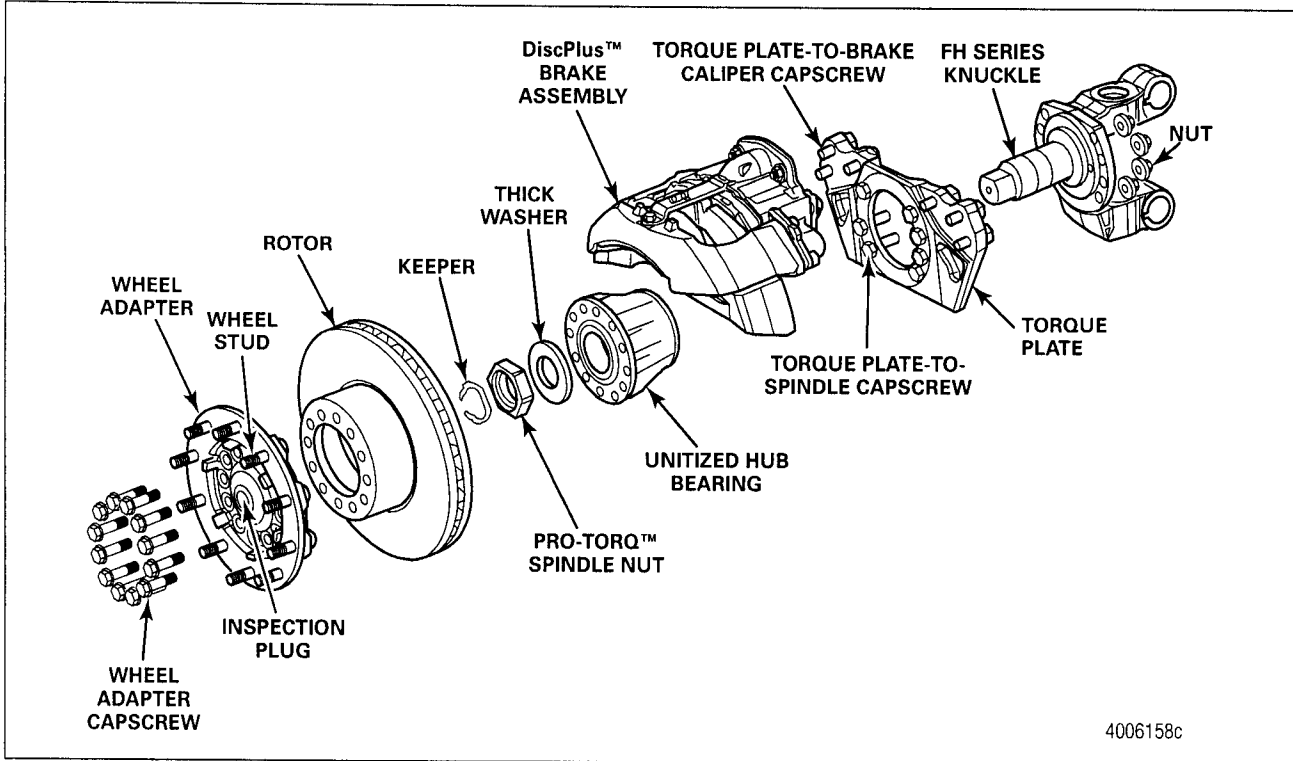

4. Use a click torque wrench to tighten all remaining bolts and any replacement bolts in a star pattern to 275 ± 25 lb-ft (373 ± 34 N•m). Record the torque on the Inspection Sheet included in this bulletin. When you have tightened all of the bolts, recheck the torque of all 12 bolts in a star pattern. 
5. Mark a stripe on all of the tightened bolts. Use a different color than the color already used.

MCI Coach — UWE Bolt Torque — Inspection Chart

VIN:	In-Service Date:	Repair Date:	Mileage:
Torque Wrench Dial Indicator — Calibration # Torque Click Wrench — Calibration #		Inspect By:	
Right Front Non-Drive Steer Wheel End Axle Serial Number:		Left Front Non-Drive Steer Wheel End	
Bolt #	Original Torque	Bolt Replaced (Yes/No)	New Torque
1			
2			
3			
4			
5			
6			
7			
8			
9			
10			
11			
12			
Comments:		Comments:	

Bolt #	Right Tag Wheel End Axle Serial Number:			Left Tag Axle Wheel End		
	Original Torque	Bolt Replaced (Yes/No)	New Torque	Original Torque	Bolt Replaced (Yes/No)	New Torque
1						
2						
3						
4						
5						
6						
7						
8						
9						
10						
11						
12						
	Comments:			Comments:		

ArvinMeritor™

Meritor Heavy Vehicle Systems, LLC
2135 West Maple Road
Troy, MI 48084 USA
800-535-5560
arvinmeritor.com

Information contained in this publication was in effect at the time the publication was approved for printing and is subject to change without notice or liability. Meritor Heavy Vehicle Systems, LLC, reserves the right to revise the information presented or to discontinue the production of parts described at any time.

Copyright 2010
ArvinMeritor, Inc.
All Rights Reserved

Printed in USA

TP-10110
Issued 05-10
(16579)