

DAIMLER

Daimler Trucks North America
Nasser Zamani
Senior Manager
Compliance and Regulatory Affairs

March 7, 2012

Nancy Lewis
Associate Administrator for Vehicle Safety
National Highway Traffic Safety Administration
1200 New Jersey Avenue S.E.
Washington D.C. 20590

**Re: Defect Information Report – Supplemental Report No. 11
10V-177 School Bus, 10V178 Non School Bus, FL-577
Hydraulic Brake Switches – Revised Dealer Bulletin**

Ms. Lewis,

In accordance with Part 573 of Title 49 of the Code of Federal Regulations, Daimler Trucks North America LLC herewith submits supplemental defect information and copies of documents distributed to dealers and purchasers.

- (c) (8)(ii) Dealer – Revised bulletin posted November 12, 2011.
Non-School Bus vehicles involved: 8,971.
School Bus vehicles involved: 6,548.
- (c) (10) Copy of Communications sent to dealers is attached.

Please contact me if you have any questions.

Sincerely yours,



Nasser Zamani

Cc: Amy Martin, CAL-OSHA
Enclosure

A Daimler Company

Daimler Trucks North America LLC
4747 N. Channel Avenue
Portland OR 97217-7699
503-745-6910 Phone
503-745-5544 Fax
Nasser.Zamani@Daimler.com

March 2012
FL577A-D
NHTSA #10V-177 (School Bus)
NHTSA #10V-178 (Non-School Bus)
Transport Canada #10-130
FOURTH REVISED NOTICE

Subject: Hydraulic Brake Switches

Models Affected: Specific Freightliner Custom Chassis B2 school bus chassis (Thomas Built Buses Saf-T-Liner C2), S2 shuttle bus chassis, MC motorhome chassis, and Freightliner Business Class M2 vehicles, manufactured January 19, 2005, through May 5, 2010.

General Information

Daimler Trucks North America LLC, on behalf of its Freightliner Trucks Division and wholly its owned subsidiary, Freightliner Custom Chassis Corporation, has decided that a defect that relates to motor vehicle safety exists on the vehicles mentioned above.

There are approximately 18,700 vehicles involved in this campaign.

Certain vehicles may have been built with stop lamps that may illuminate intermittently during light brake applications. Stop lamps that do not properly indicate that the service brakes are applied may lead to a possible vehicle crash.

The hydraulic brake switches will be replaced to control stop lamp functionality. The hydraulic brake pedals will be inspected for side-to-side play and twist and will be replaced as necessary.

REVISIONS: Table 1 - Replacement Parts for FL577 has been corrected to show that all groups in the Recall, including FL577C, may use kit 25-FL577-002 when needed (a vehicle has a fixed brake pedal and the pedal fails the inspection). For MC motorhome chassis in FL577C, check PartsPro for the correct fixed brake pedal part number.

Additional Repairs

Dealers must complete all outstanding recall and field service campaigns prior to the sale or delivery of a vehicle. A Dealer will be liable for any progressive damage that results from its failure to complete campaigns before sale or delivery of a vehicle.

Owners may be liable for any progressive damage that results from its failure to complete campaigns within a reasonable time after receiving notification.

Work Instructions

Please refer to the attached work instructions. Prior to performing the campaign, check the vehicle for a completion sticker (Form WAR260).

Replacement Parts

Replacement kits are now available and can be obtained by ordering the kit number(s) listed below from your facing Parts Distribution Center.

If our records show your dealership has ordered any vehicles involved in campaign number FL577A-D, a list of the customers and vehicle identification numbers will be available on AccessFreightliner.com. Please refer to this list when ordering parts for this recall.

Recall Campaign

Daimler Trucks
North America LLC

March 2012
FL577A-D
NHTSA #10V-177 (School Bus)
NHTSA #10V-178 (Non-School Bus)
Transport Canada #10-130
FOURTH REVISED NOTICE

Table 1 - Replacement Parts for FL577

Campaign Number	Kit Number	Part Description	Part Number	Qty. per Kit	Suggested Wholesale*
FL577A/B/D	25-FL577-000	Harn-Jumper, Brk Svce, Sw, B2/ M2	A06-79110-001	1 ea	\$64.53 U.S. \$63.88 CAN
		Switch, Brk Lt, Bendix, 12 lbs.	06-79232-000	1 ea	
		Clip Hold Down	TDA 2257D1174	1 ea	
		Pin, Clevis, Hardened	23-13811-001	1 ea	
		Washer-Hrdn, .578X1.16X121, ZN	A 680 990 08 40 (in Paragon) MBT A6809900840 (in Co-op)	2 ea	
		Clamp-Cable Tie 36.25", 0-11"	23-09796-809	2 ea	
		Completion Sticker	WAR260	1 ea	
FL577C	25-FL577-001	Harn-Jumper, Brak Svce, Sw B2/ M2	A06-79110-002	1 ea	\$64.70 U.S. \$64.05 CAN
		Switch-Brk Lt., Bendix, 12 lbs.	06-79232-000	1 ea	
		Clip Hold Down	TDA 2257D1174	1 ea	
		Pin, Clevis, Hardened	23-13811-001	1 ea	
		Washer-Hrdn, .578X1.16X121, ZN	A 680 990 08 40 (in Paragon) MBT A6809900840 (in Co-op)	2 ea	
		Clamp-Cable Tie 36.25", 0-11"	23-09796-809	2 ea	
		Completion Sticker	WAR260	1 ea	
FL577A-D (All vehicles except MC motorhome chassis)	25-FL577-002	Fixed Brk Pedal Hyd	A12-19130-000 (For MC motorhome chassis in FL577C, check PartsPro for the correct fixed brake pedal part number)	1 ea	\$129.52 U.S. \$132.11 CAN

* Please charge all Direct Warranty Customers the above-listed price for the kit, as they are authorized to perform their own Recalls.

Table 1

Removed Parts

Please follow Warranty Failed Parts Tracking shipping instructions for the disposition of all removed parts.

Labor Allowance

Table 2 - Labor Allowance

Campaign Number	Procedure	Time Allowed (hours)	SRT Code	Damage Code
FL577A-D	Replace Hydraulic Brake Light Switch	0.3	996-0827A	000-Modifiedx
	Replace Hydraulic Brake Light Switch and Replace Fixed Hydraulic Brake Pedal	2.7	996-0827B	000-Modifiedx

Table 2

March 2012
FL577A-D
NHTSA #10V-177 (School Bus)
NHTSA #10V-178 (Non-School Bus)
Transport Canada #10-130
FOURTH REVISED NOTICE

IMPORTANT: When the recall has been completed, locate the base completion label in the appropriate location on the vehicle, and attach the red completion sticker provided in the recall kit (Form WAR260). If the vehicle does not have a base completion label, clean a spot on the appropriate location of the vehicle and first attach the base completion label (Form WAR259). If a recall kit is not required or there is no completion sticker in the kit, write the recall number on a blank sticker and attach it to the base completion label.

Claims for Credit

You will be reimbursed for your parts, labor, and handling by submitting your claim through the Warranty system within 30 days of completing this campaign. Please reference the following information in QuickClaim®:

REVISIONS: Table 1 - Replacement Parts for FL577 has been corrected to show that all groups in the Recall, including FL577C, may use kit 25-FL577-002 when needed (a vehicle has a fixed brake pedal and the pedal fails the inspection). For MC motorhome chassis in FL577C, check PartsPro for the correct fixed brake pedal part number.

NOTE: FCCC Engineering has determined that some MC motorhome chassis were not manufactured with the brake switch that is the subject of this Recall. Administrative claims have been entered for these vehicles to close the Recall. No work is needed for any vehicle with claim "FLWA009999999."

- Claim type is **Recall**.
- In the FTL Authorization field, enter the campaign number and appropriate condition code (e.g. **FL577A, FL577B, etc.**).
- In the Primary Failed Part Number field, enter **25-FL577-000**.
- In the Parts field, enter the appropriate kit number(s) as shown in the Replacement Parts Table. Up to \$2.00 in miscellaneous tie straps may be claimed.
- In the Labor field, first enter the appropriate SRT from the Labor Allowance Table. For administrative time, enter SRT 939-0010A for 0.4 hours for RVs or 0.3 hours for all other vehicles.
- For OWL, the VMRS Component Code is 013-005-001.
- **Reimbursement for Prior Repairs.** When a customer asks about reimbursement, please do the following.
 - Accept the documentation of the previous repair.
 - Make a brief check of the customer's paperwork to see if the repair may be eligible for reimbursement. (See the "Copy of Owner Letter" section of this bulletin for reimbursement guidelines for this recall.)
 - Submit a Campaign Pre-Approval inquiry to the Warranty Campaigns Department for a decision and authorization number.
 - Include the approved amount on your claim in sublet/outside purchases.
 - In the claim story, first note the authorization number and that the claim includes a reimbursement request.
 - Retain the documentation and provide it to Warranty Campaigns or Claims Processing if requested.
 - When your claim is paid, reimburse the customer the appropriate amount.

IMPORTANT: ServicePro® must be viewed prior to performing the recall to ensure the vehicle is involved and the campaign has not been previously completed. Also, check for a completion sticker prior to beginning work.

Contact the Warranty Campaigns Department from 7:00 a.m. to 4:00 p.m. Pacific Time, Monday through Friday, via Web inquiry at AccessFreightliner.com / Support / Submit an Inquiry, or the Customer Assistance Center at (800) 385-4357, after normal business hours, if you have any questions or need additional information.

Recall Campaign

Daimler Trucks
North America LLC

March 2012

FL577A-D

NHTSA #10V-177 (School Bus)

NHTSA #10V-178 (Non-School Bus)

Transport Canada #10-130

FOURTH REVISED NOTICE

To return excess kit inventory related to this campaign, U.S. dealers must submit a Parts Authorization Return (PAR) to the Memphis PDC. Canadian dealers must submit a PAR to their facing PDC. All kits must be in resalable condition. PAR requests must include the original purchase invoice number.

The letter notifying vehicle owners is included for your reference.

Please note that the National Traffic and Motor Vehicle Safety Act, as amended (Title 49, United States Code, Chapter 301), requires the owner's vehicle(s) be corrected within a reasonable time after parts are available to you. The Act states that failure to repair a vehicle within 60 days after tender for repair shall be prima facie evidence of an unreasonable time. However, circumstances of a particular situation may reduce the 60 day period. Failure to repair a vehicle within a reasonable time can result in either the obligation to (a) replace the vehicle with an identical or reasonably equivalent vehicle, without charge, or (b) refund the purchase price in full, less a reasonable allowance for depreciation. The Act further prohibits dealers from selling a vehicle unless all outstanding recalls are performed. Any lessor is required to send a copy of the recall notification to the lessee within 10 days. Any subsequent stage manufacturer is required to forward this notice to its distributors and retail outlets within five working days.

March 2012
FL577A-D

NHTSA #10V-177 (School Bus)
NHTSA #10V-178 (Non-School Bus)

Transport Canada #10-130
FOURTH REVISED NOTICE

Copy of Letter to Owner

Subject: Hydraulic Brake Switches

For the Notice to U.S. Customers: This notice is sent to you in accordance with the requirements of the National Traffic and Motor Vehicle Safety Act.

For the Notice to Canadian Customers: This notice is sent to you in accordance with the Canadian Motor Vehicles Safety Act.

Daimler Trucks North America LLC, on behalf of its Freightliner Trucks Division and wholly owned subsidiary, Freightliner Custom Chassis Corporation, has decided that a defect which relates to motor vehicle safety exists on specific Freightliner Custom Chassis B2 school bus chassis (Thomas Built Buses Saf-T-Liner C2), S2 shuttle bus chassis, MC motorhome chassis, and Freightliner Business Class M2 vehicles, manufactured January 19, 2005, through May 5, 2010.

Certain vehicles may have been built with stop lamps that may illuminate intermittently during light brake applications. Stop lamps that do not properly indicate that the service brakes are applied may lead to a possible vehicle crash.

The hydraulic brake switches will be replaced to control stop lamp functionality. The hydraulic brake pedals will be inspected for side-to-side play and twist and will be replaced as necessary.

Please contact an authorized Daimler Trucks North America dealer to arrange to have the recall performed and to ensure that parts are available at the dealership. To locate an authorized dealer, search online at www.Daimler-TrucksNorthAmerica.com. The Recall may take up to three hours depending on the work needed and will be performed at no charge to you.

IMPORTANT: When the Recall has been completed, please ensure that the dealer has affixed a red recall sticker (either pre-printed or handwritten) to the base label on your vehicle referencing FL577. On trucks, the base label is usually located on the passenger-side door, about 12 inches below the door latch. On school buses and shuttle buses, the base label is usually located over the driver's window. On motorhomes, the base label is usually located on the front wall, under the dash. If there is no completion sticker, please ask your dealer for one after the recall has been completed.

If you do not own the vehicle that corresponds to the identification number(s) which appears on the Recall Notification, please return the notification to the Warranty Campaigns Department with any information you can furnish that will assist us in locating the present owner. If you have leased this vehicle, Federal law requires that you forward this notice to the lessee within 10 days. If you are a subsequent stage manufacturer, Federal law requires that you forward this notice to your distributors and retail outlets within five working days. If you have paid to have this recall condition corrected prior to this notice, you may be eligible to receive reimbursement. Please see the reverse side of this notice for details.

For the Notice to U.S. Customers: If you have questions about this Recall, please contact the Warranty Campaigns Department at (800) 547-0712, 7:00 a.m. to 4:00 p.m. Pacific Time Monday through Friday, e-mail address DTNA.Warranty.Campaigns@Daimler.com, or the Customer Assistance Center at (800) FTL-HELP after normal business hours. If you are not able to have the defect remedied without charge and within a reasonable time, which is not longer than 60 days after you tender the vehicle for repair, you may wish to submit a complaint to the Administrator, National Highway Traffic Safety Administration, 1200 New Jersey Avenue, SE., Washington, DC 20590; or call the Vehicle Safety Hotline at (888) 327-4236 (TTY: 800-424-9153); or to <http://www.safercar.gov>.

For the Notice to Canadian Customers: If you have questions about this Recall, please contact the Warranty Campaigns Department at (800) 547-0712, 7:00 a.m. to 4:00 p.m. Pacific Time Monday through Friday, e-mail address DTNA.Warranty.Campaigns@Daimler.com, or the Customer Assistance Center at (800) FTL-HELP after normal business hours.

Recall Campaign

Daimler Trucks
North America LLC

March 2012
FL577A-D
NHTSA #10V-177 (School Bus)
NHTSA #10V-178 (Non-School Bus)
Transport Canada #10-130
FOURTH REVISED NOTICE

We regret any inconvenience this action may cause but feel certain you understand our interest in motor vehicle safety.

WARRANTY CAMPAIGNS DEPARTMENT

Enclosure

March 2012

FL577A-D

NHTSA #10V-177 (School Bus)

NHTSA #10V-178 (Non-School Bus)

Transport Canada #10-130

FOURTH REVISED NOTICE

Reimbursement to Customers for Repairs Performed Prior to Recall

If you have already **paid** to have this recall condition corrected you may be eligible to receive reimbursement.

Requests for reimbursement may include parts and labor. Reimbursement may be limited to the amount the repair would have cost if completed by an authorized Daimler Trucks North America LLC dealer. The following documentation must be presented to your dealer for consideration for reimbursement.

Please provide original or clear copies of all receipts, invoices, and repair orders that show:

- The name and address of the person who paid for the repair.
- The Vehicle Identification Number (VIN) of the vehicle that was repaired.
- What problem occurred, what repair was done, when the repair was done.
- Who repaired the vehicle.
- The total cost of the repair expense that is being claimed.
- Proof of payment for the repair (such as the front and back of a cancelled check or a credit card receipt).

Reimbursement will be made by check from your Daimler Trucks North America LLC dealer.

Please speak with your Daimler Trucks North America LLC authorized dealer concerning this matter.

March 2012
FL577A-D
NHTSA #10V-177 (School Bus)
NHTSA #10V-178 (Non-School Bus)
Transport Canada #10-130
FOURTH REVISED NOTICE

Work Instructions

Subject: Hydraulic Brake Switches

Models Affected: Specific Freightliner Custom Chassis B2 school bus chassis (Thomas Built Buses Saf-T-Liner C2), S2 shuttle bus chassis, MC motorhome chassis, and Freightliner Business Class M2 vehicles, manufactured January 19, 2005, through May 5, 2010.

REVISIONS: FCCC Engineering has determined that some MC motorhome chassis were not manufactured with the brake switch that is the subject of this Recall. Administrative claims have been entered for these vehicles to close the Recall. No work is needed for any vehicle with claim "FLWA009999999." A small group of S2 shuttle bus chassis have been moved to FL577D; see the Replacement Parts and Labor Allowance Tables for the appropriate kits and SRTs.

NOTE: FCCC Engineering has determined that some MC motorhome chassis were not manufactured with the brake switch that is the subject of this Recall. Administrative claims have been entered for these vehicles to close the Recall. No work is needed for any vehicle with claim "FLWA009999999."

Hydraulic Brake Pedal Inspection

1. Check the base label (Form WAR259) for a completion sticker for FL577 (Form WAR260) indicating this work has been done. On trucks, the base label is usually located on the passenger-side door, about 12 inches (30 cm) below the door latch. On school buses and shuttle buses, the base label is usually located over the driver's window. On motorhomes, the base label is usually located on the front wall, under the dash. If a completion sticker is present, no further work is needed. If a completion sticker is not present, continue with the next step.
2. Park the vehicle on a level surface, shut down the engine, apply the parking brake, and chock the tires.
3. Determine whether the brake pedal is fixed or adjustable. See Fig. 1 and Fig. 2.

If the brake pedal is adjustable, no inspection is needed. Go to "Hydraulic Brake Light Switch Replacement" in these Work Instructions.

If the brake pedal is fixed, go to the next step.

4. Inspect the brake pedal for side-to-side play by moving the pedal from left to right. Measure travel at the brake pedal cover.

If the side-to-side play is *more than 6 mm*, replace the brake pedal. Go to "Hydraulic Brake Pedal Replacement" in these Work Instructions.

If the side-to-side play is *6 mm or less*, do **not** replace the pedal. Go to "Hydraulic Brake Light Switch Replacement" in these Work Instructions.

Hydraulic Brake Light Switch Replacement

1. Locate the brake switch on the brake pedal. See Fig. 1 for location on a fixed brake pedal. See Fig. 2 for the location on an adjustable brake pedal.
2. Cut the tie strap on the harness leads going to the brake switch, and unplug the switch.
3. Remove the cotter pin, flatwashers, clevis pin, and brake switch and discard all of these parts.

March 2012

FL577A-D

NHTSA #10V-177 (School Bus)

NHTSA #10V-178 (Non-School Bus)

Transport Canada #10-130

FOURTH REVISED NOTICE

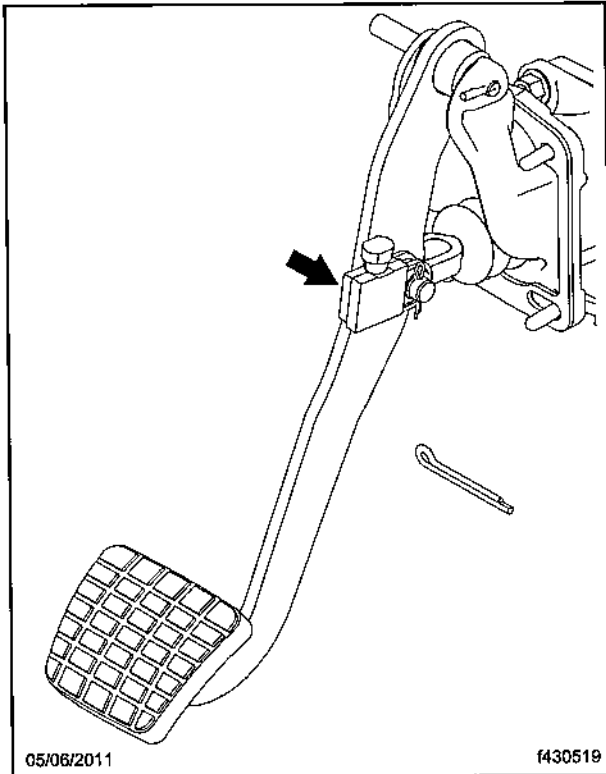

Fig. 1, Brake Switch Location, Fixed Brake Pedal

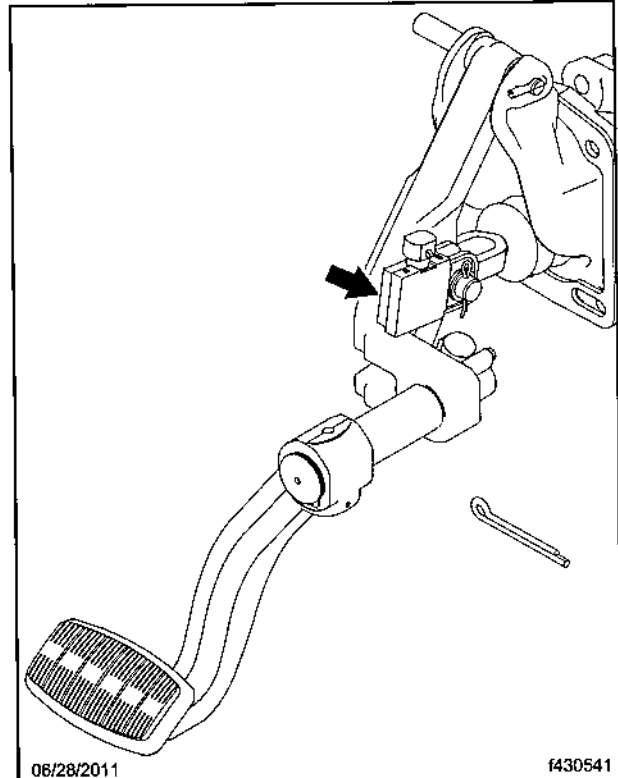

Fig. 2, Brake Switch Location, Adjustable Brake Pedal

4. Install the new clevis pin, flatwashers, brake switch, and hitch pin from the kit. Make certain one flatwasher is between the pushrod and the brake lever as shown in Fig. 3.

Make certain the other flatwasher is between the brake switch and the hitch pin, and that the hitch pin is installed as shown in Fig. 4 for fixed brake pedal installations, or Fig. 5 for adjustable brake pedal installations.

For vehicles with an adjustable pedal, go to Step 6.

For vehicles with a fixed pedal, go to the next step.

5. Using a feeler gauge, measure the space between the flatwasher and the brake pedal as shown in Fig. 3.
If the gap is *less than 1.2 mm*, replace the brake pedal. Go to "Hydraulic Brake Pedal Replacement" in these Work Instructions.
If the gap is *1.2 mm or more*, no further work is needed.
6. Attach the new harness pigtail to the existing harness and the newly installed brake switch. Use tie straps to secure excess wiring away from the throttle pedal.
7. Check for proper brake light operation.
8. Clean a spot on the base label (Form WAR259) and attach a completion sticker for FL577 (Form WAR260) to the base label.

Recall Campaign

Daimler Trucks
North America LLC

March 2012
FL577A-D
NHTSA #10V-177 (School Bus)
NHTSA #10V-178 (Non-School Bus)
Transport Canada #10-130
FOURTH REVISED NOTICE

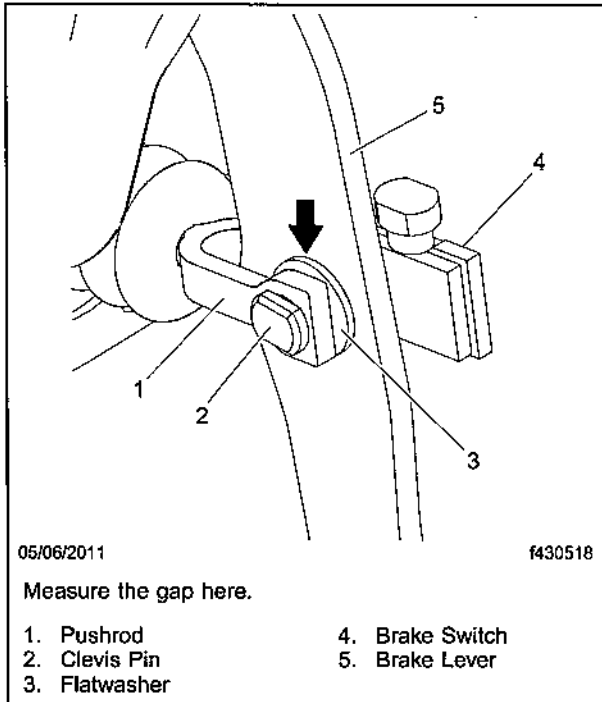

Fig. 3, Brake Switch Installation (fixed pedal shown)

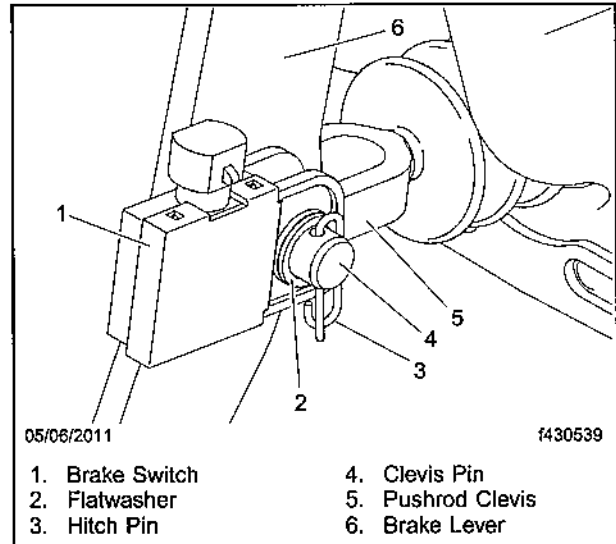

Fig. 4, New Brake Switch Installation (fixed pedal)

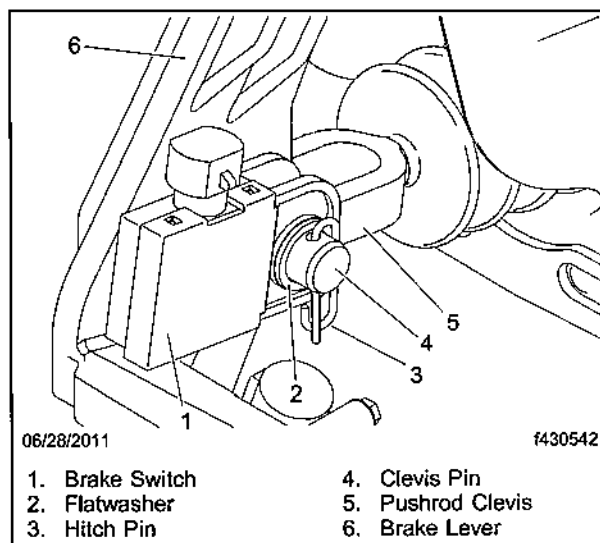

Fig. 5, New Brake Switch Installation (adjustable pedal)

March 2012
FL577A-D
NHTSA #10V-177 (School Bus)
NHTSA #10V-178 (Non-School Bus)
Transport Canada #10-130
FOURTH REVISED NOTICE

Fixed Hydraulic Brake Pedal Replacement

IMPORTANT: This procedure is for fixed brake pedal assemblies only. Do not replace adjustable brake pedals.

1. Remove the cotter pin from the brake clevis and remove the clevis pin from the brake pedal. See Fig. 6.
2. Disconnect the master cylinder from the brake cylinder and support the master cylinder by zip tying it to the engine. Be careful not to bend the hydraulic hard lines.

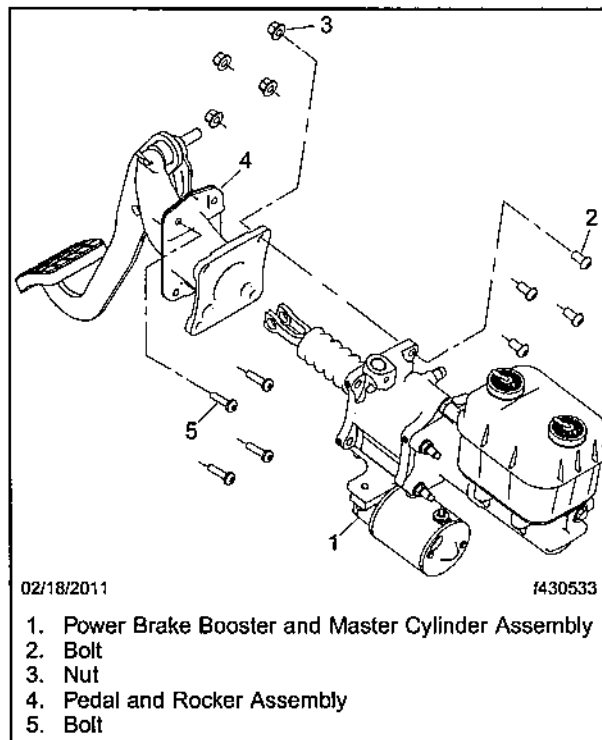

Fig. 6, Removing the Fixed Brake Pedal

3. Remove the bolts holding the brake pedal to the frontwall, then pull the brake pedal through the frontwall.
4. Use the existing bolts and install the new brake pedal. Tighten the bolts 10 to 13 lbf-ft (14 to 18 N-m).
5. Connect the master cylinder to the brake pedal.
6. Go to "Hydraulic Brake Light Switch Replacement" in these Work Instructions.