



# Recall Bulletin



## PRODUCT SAFETY RECALL

**SUBJECT:** Voltage Regulator Internal Low Resistance Short

**MODELS:** Various Serviced Vehicles

Parts involved in this recall were used to service various GM vehicles. Dealers who ordered these part(s) for service are identified in the attachment contained in the dealer message announcing this recall. Please refer to the section titled, Dealer Recall Responsibility, for additional details and instructions.

As an important precaution to prevent possible fire, until the inspection procedure for this recall is completed, all vehicles should have both battery cables disconnected immediately. Until the battery cables are disconnected, do not park these vehicles inside a garage, car port or other structure.

### CONDITION

Remy, who supplies generators to GM, has decided that a defect, which relates to motor vehicle safety, exists in **certain** 145 amp generator. Some GM vehicles may have been serviced with these generators. These generators may develop a low resistance short within the voltage regulator. If this occurs, an open circuit could be created which would illuminate the generator lamp in the instrument panel, or in some cases, cause an engine compartment fire.

### CORRECTION

Dealers are to inspect and, if necessary, replace the generator.

Dealers who have ordered the involved components for service have been identified in the report that accompanied the dealer message announcing this recall. Identified dealers are to search their part sales records to determine the name and address of the purchaser(s). If the purchaser is the owner of the vehicle, dealers/retailers are to send the owner a copy of the appropriate letter found in this bulletin requesting that their vehicle be brought in for repair. If the purchaser is a body shop, independent repair shop, etc., dealers are to contact the repair facility and obtain the owner's name and address so the dealer can send the owner a copy of the letter.

### VEHICLES INVOLVED

Involved are **certain** GM vehicles that were serviced with a replacement 145 amp generator and generators that were sold over-the-counter.

For dealers with identified involved vehicles, a listing with involved vehicles containing the complete vehicle identification number, customer name, and address information has been prepared and will be provided to US and Canadian dealers through the GM GlobalConnect Recall Reports, or sent directly to export dealers. Dealers will not have a report available if they have no identifiable involved vehicles currently assigned.

Dealers that have ordered involved parts for service will be identified in the report contained in the dealer message announcing this recall.

The listing may contain customer names and addresses obtained from Motor Vehicle Registration Records. The use of such motor vehicle registration data for any purpose other than follow-up necessary to complete this recall is a violation of law in several states/provinces/countries. Accordingly, you are urged to limit the use of this report to the follow-up necessary to complete this recall.

### PARTS INFORMATION

Generators required to complete this recall are to be obtained from General Motors Customer Care and Aftersales (GMCC&A). Order the appropriate generator as needed. **Please note that only vehicles that do not pass the generator date code inspection will require parts.** Orders should be placed as CSO3 = Customer Special Order Advisory Code 3. This will allow orders to write directly to your Admin PDC. If your Admin PDC does not have inventory it will then automatically refer to a distribution center with inventory for next day delivery.

## SERVICE PROCEDURE

Only the generator part numbers listed below are involved in this recall.

- 15263859
- 15845338
- 15847291
- 94665498

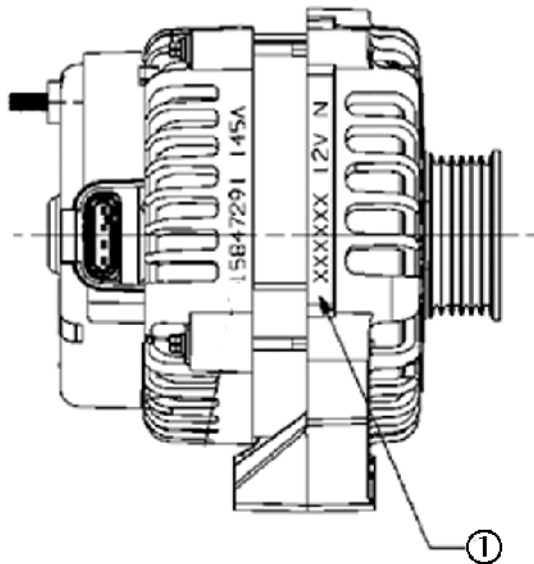

2426929

**Generator Build Date Location** is at the 11 o'clock position on gasoline engines and at the 2 o'clock position for diesel engines. (1) Gasoline Engine Generator Build Date Location shown.

**Note:** The first character in the date code identifies which plant that the generator was built. The next two digits are for the day of month the generator was built. The next two characters are for the month that the generator was built. The next two digits are for the year that the generator was built. The last character is for the production cell and shift. An example date code is M 13 DE 10 A. The plant is Mexico. The day of the month is 13, the month is December, and the year is 2010. The production cell and shift is A.

**Note:** If the vehicle is equipped with an auxiliary generator, **INSPECT** the generator build date to determine if it must be replaced.

1. Determine build date of the generator. Refer to the illustration for build date location.
  - If the generator build date is January 12, 2010 or later, remove the generator and replace it with a new one; proceed to Step 2.
  - If the generator build date is BEFORE January 12, 2010, replacement of the generator is NOT required. No further action is required.
2. Remove the generator and auxiliary generator, if required, from the vehicle. Refer to the appropriate *Generator Replacement and/or Auxiliary Generator Replacement* in SI.
3. Install the new generator. Refer to the appropriate *Generator Replacement and/or Auxiliary Generator Replacement* in SI.

CLAIM INFORMATION

1. Submit a claim using the table below.

<b>Labor Code</b>	<b>Description</b>	<b>Labor Time</b>
For Vehicles That Are Listed In GWM		
V2294	Gas Engine – Inspect Date Code – No Repair Required	0.2
V2295	Diesel Engine – Inspect Date Code – No Repair Required	0.3
V2296	Inspect Date Code & Replace Generator	*
For Vehicles That Are Not Listed in GWM But Have Been Serviced With A Suspect Generator		
T5776	Record Search for Owner Name & Address – Time Allowance Includes Time Searching for Purchaser's Name and Address & Expense Incurred Mailing the Owner Letter	**
T5777	Gas Engine – Inspect Date Code – No Repair Required	0.2
T5778	Diesel Engine – Inspect Date Code – Repair Required	0.3
T5779	Inspect Date Code & Replace Generator	*

- \* Submit appropriate published time found in the Labor Time Guide for the generator replacement plus the inspection time of 0.2 labor time for gas engines, 0.3 for diesel engines.
- \*\* After all records have been searched, submit one claim for the total time. The total time should be 0.3 hours times the total number of names and addresses found. This labor code can only be submitted once per dealer.

CUSTOMER NOTIFICATION – For US and Canada

General Motors will notify customers of record of this recall on their vehicle (see copy of customer letter included with this bulletin). Dealers that have been identified as having over-the-counter sales are to inspect their sales records to determine the purchaser of these generators. After determining the name and address of the purchaser, dealers are to send each owner a copy of the attached owner letter requesting that their vehicle be brought in for inspection.

CUSTOMER NOTIFICATION – For Export

Letters will be sent to known owners of record located within areas covered by the US National Traffic and Motor Vehicle Safety Act. For owners outside these areas, dealers should notify customers using the attached sample letter. Dealers that have been identified as having over-the-counter sales are to inspect their sales records to determine the purchaser of these generators. After determining the name and address of the purchaser, dealers are to send each owner a copy of the attached owner letter requesting that their vehicle be brought in for inspection.

DEALER RECALL RESPONSIBILITY – For US and Export (US States, Territories, and Possessions)

The US National Traffic and Motor Vehicle Safety Act provides that each vehicle that is subject to a recall of this type must be adequately repaired within a reasonable time after the customer has tendered it for repair. A failure to repair within sixty days after tender of a vehicle is prima facie evidence of failure to repair within a reasonable time. If the condition is not adequately repaired within a reasonable time, the customer may be entitled to an identical or reasonably equivalent vehicle at no charge or to a refund of the purchase price less a reasonable allowance for depreciation. To avoid having to provide these burdensome remedies, every effort must be made to promptly schedule an appointment with each customer and to repair their vehicle as soon as possible. In the recall notification letters, customers are told how to contact the US National Highway Traffic Safety Administration if the recall is not completed within a reasonable time.

DEALER RECALL RESPONSIBILITY – All

Dealers who have ordered the recalled part for service are identified in the attachment contained in the dealer message announcing this recall. Dealers who have received this listing are required to inspect their sales records to determine the name and address of the purchaser of these generators.

If the purchaser is the owner of the vehicle, dealers are to send the owner a copy of the attached owner letter requesting that their vehicle be brought in for inspection.

If the purchaser is NOT the owner of the vehicle, i.e., body shop, independent repair shop, etc., dealers are to contact the repair facility and obtain the owner's name and address so a copy of the owner letter can be sent to these owners

Since General Motors Customer Care and Aftersales records do not contain customer names and addresses for these over-the-counter sales, it is important that each involved dealer take the necessary time required to responsibly identify customers who have purchased these generators.

All vehicles in dealers' possession and subject to this recall must be held and inspected/repaired per the service procedure of this recall bulletin before customers take possession of these vehicles.

Dealers are to service all vehicles subject to this recall at no charge to customers, regardless of mileage, age of vehicle, or ownership, from this time forward.

Customers who have recently purchased vehicles sold from your vehicle inventory, and for which there is no customer information indicated on the dealer listing, are to be contacted by the dealer. Arrangements are to be made to make the required correction according to the instructions contained in this bulletin. A copy of the customer letter is provided in this bulletin for your use in contacting customers. You should recommend that the customer not park the vehicle in a garage, car port, or other structure. Recall follow-up cards should not be used for this purpose, since the customer may not as yet have received the notification letter.

In summary, whenever a vehicle subject to this recall enters your vehicle inventory, or is in your dealership for service in the future, you must take the steps necessary to be sure the recall correction has been made before selling or releasing the vehicle.



*(Letter for customers who had the generator replaced under warranty)*

Dear General Motors Customer:

This notice is sent to you in accordance with the requirements of the National Traffic and Motor Vehicle Safety Act.

Remy, who supplies generators to GM, has decided that a defect, which relates to motor vehicle safety, exists in **certain** 145 amp generator. As a result, GM is conducting a safety recall. We apologize for this inconvenience. However, we are concerned about your safety and continued satisfaction with our products.

## IMPORTANT

- Your vehicle is involved in safety recall 10117.
- Schedule an appointment with your GM dealer
- This service will be performed for you at **no charge**.

### Why is your vehicle being recalled?

Our records indicate that your vehicle may have been serviced with one of the recalled generators. These generators may have a condition in which the generator may develop an internal short circuit. If this occurs, an open circuit could be created, which would illuminate the generator lamp in the instrument panel. In some cases, the short circuit could eventually generate enough heat to result in an engine compartment fire.

### What will we do?

Your GM dealer will inspect your vehicle's electrical system and if necessary replace the alternator. This service will be performed for you at **no charge**. Because of service scheduling requirements, it is likely that your dealer will need your vehicle longer than the actual time for the inspection, and if required, replacement of the generator.

### What should you do?

You should contact your GM dealer to arrange a service appointment as soon as possible.

As an important precaution you should take before your vehicle is serviced:

- We strongly recommend you not park your vehicle in a garage, car port, or other structure.

### Do you have questions?

If you have questions or concerns that your dealer is unable to resolve, please contact GM's Customer Assistance Center.

If after contacting your dealer and the Customer Assistance Center, you are still not satisfied we have done our best to remedy this condition without charge and within a reasonable time, you may wish to write the Administrator, National Highway Traffic Safety Administration, 1200 New Jersey Avenue, SE, Washington DC 20590, or call the toll-free Vehicle Safety Hotline at 1.888.327.4236 (TTY 1.800.424.9153), or go to <http://www.safercar.gov>.

Federal regulation requires that any vehicle lessor receiving this recall notice must forward a copy of this notice to the lessee within ten days.

Scott Lawson  
Director,  
Customer and Relationship Services

10117



*(Letter for customers who purchased a generator over the counter)*

Dear General Motors Customer:

This notice is sent to you in accordance with the requirements of the National Traffic and Motor Vehicle Safety Act.

Remy, who supplies generators to GM, has decided that a defect, which relates to motor vehicle safety, exists in **certain** 145 amp generator. As a result, GM is conducting a safety recall. We apologize for this inconvenience. However, we are concerned about your safety and continued satisfaction with our products.

## IMPORTANT

- Your vehicle is involved in safety recall 10117.
- Schedule an appointment with your GM dealer
- This service will be performed for you at **no charge**.

### Why is your vehicle being recalled?

Our records indicate that you may have purchased one of the recalled generators. These generators may have a condition in which the generator may develop an internal short circuit. If this occurs, an open circuit could be created, which would illuminate the generator lamp in the instrument panel. In some cases, the short circuit could eventually generate enough heat to result in an engine compartment fire.

### What will we do?

Your GM dealer will inspect your vehicle's electrical system and if necessary replace the alternator. This service will be performed for you at **no charge**. Because of service scheduling requirements, it is likely that your dealer will need your vehicle longer than the actual time for the inspection, and if required, replacement of the generator.

### What should you do?

You should contact your GM dealer as soon as possible to arrange a service appointment to have the involved vehicle inspected. .

As an important precaution you should take before your vehicle is serviced:

- We strongly recommend you not park your vehicle in a garage, car port, or other structure.

### Do you have questions?

If you have questions or concerns that your dealer is unable to resolve, please contact GM's Customer Assistance Center.

If after contacting your dealer and the Customer Assistance Center, you are still not satisfied we have done our best to remedy this condition without charge and within a reasonable time, you may wish to write the Administrator, National Highway Traffic Safety Administration, 1200 New Jersey Avenue, SE, Washington DC 20590, or call the toll-free Vehicle Safety Hotline at 1.888.327.4236 (TTY 1.800.424.9153), or go to <http://www.safercar.gov>.

Federal regulation requires that any vehicle lessor receiving this recall notice must forward a copy of this notice to the lessee within ten days.

Scott Lawson  
Director,  
Customer and Relationship Services

Enclosure  
10117