

# SAFETY RECALL BULLETIN

SUBJECT:			No: <b>SR-10-002REV</b>
<b>2004 ENDEAVOR FUEL FILLER PIPE — SAFETY RECALL CAMPAIGN</b>			DATE: <b>December, 2010</b>
			MODEL: <b>2004 Endeavor</b>
CIRCULATE TO:	<input checked="" type="checkbox"/> GENERAL MANAGER	<input checked="" type="checkbox"/> PARTS MANAGER	<input checked="" type="checkbox"/> TECHNICIAN
<input checked="" type="checkbox"/> SERVICE ADVISOR	<input checked="" type="checkbox"/> SERVICE MANAGER	<input checked="" type="checkbox"/> WARRANTY PROCESSOR	<input checked="" type="checkbox"/> SALES MANAGER

***This bulletin supercedes SR-10-002, issued June, 2010, to delete the fuel filler pipe inspection process. Dealers should replace the fuel filler pipe on ALL affected vehicles. Revised information is italicized and indicated by ◀.***

## PURPOSE

Affected vehicles operated in Canada and certain states listed below, where road salt is used in cold conditions, may experience fuel filler pipe corrosion. Mud mixed with road salt can become trapped in the fuel filler pipe area, potentially causing corrosion of the pipe. Over time, corrosion could create a leak in the pipe, leading to fuel leakage during vehicle refueling. ***Dealers must install a new, improved part, using the fuel filler pipe repair kit listed in the PARTS INFORMATION section of this bulletin.*** ◀

## AFFECTED VEHICLES

2004 Endeavor models only

This campaign applies only to affected vehicles sold in or shipped to, registered or residing in the following states and Canada:

Alaska	Indiana	Minnesota	North Dakota	Utah
Arkansas	Iowa	Missouri	Ohio	Vermont
Colorado	Kansas	Montana	Oklahoma	Virginia
Connecticut	Kentucky	Nebraska	Oregon	Washington
Delaware	Maine	New Hampshire	Pennsylvania	West Virginia
District of Columbia	Maryland	New Jersey	Rhode Island	Wisconsin
Idaho	Massachusetts	New York	South Dakota	Wyoming
Illinois	Michigan	North Carolina	Tennessee	CANADA

### ***IMPORTANT***

***Affected used inventory vehicles must be repaired before the vehicle is sold. Dealers must check their inventory vehicles' VINs on the Warranty Super Screen to verify whether the vehicle is involved in this recall campaign.***

## CUSTOMER NOTIFICATION

A letter will be sent to all owners of affected vehicles requesting them to bring their vehicle to their Mitsubishi Motors dealer to have the fuel filler pipe replaced. A copy of the customer notification letter appears at the end of this bulletin.

## REQUIRED OPERATIONS

Before starting this campaign procedure, **CHECK ON THE WARRANTY SUPERSCREEN** to verify that the vehicle is an affected VIN for this campaign and that this campaign procedure has not already been completed.

FILE UNDER:	<b>Safety Recall Bulletins in the Dealer Service Information Binder</b>	<b>(3721)</b>
-------------	---	---------------

## FUEL FILLER PIPE REPLACEMENT PROCEDURE

**IMPORTANT:** The fuel tank level reading on the gauge should be less than 1/2 tank before starting this procedure. If necessary, remove fuel and store it in a clean container approved for gasoline storage. You will return this fuel to the vehicle after the repair is complete.

### **⚠ WARNING**

- Gasoline is extremely flammable and explosive. The vehicle should be in a well-ventilated area.
- Make certain that no ignition sources (i.e., pilot lights, cigarettes and lighters, electrical motors and switches, etc.) are near the repair area.
- Be sure that fire extinguishers are located in the immediate repair area.
- Wipe up any gasoline spills immediately.

### **Fuel Filler Pipe Assembly Removal**

1. Turn the ignition key to the OFF position.
2. Remove the three bolts securing the fuel filler pipe flange.

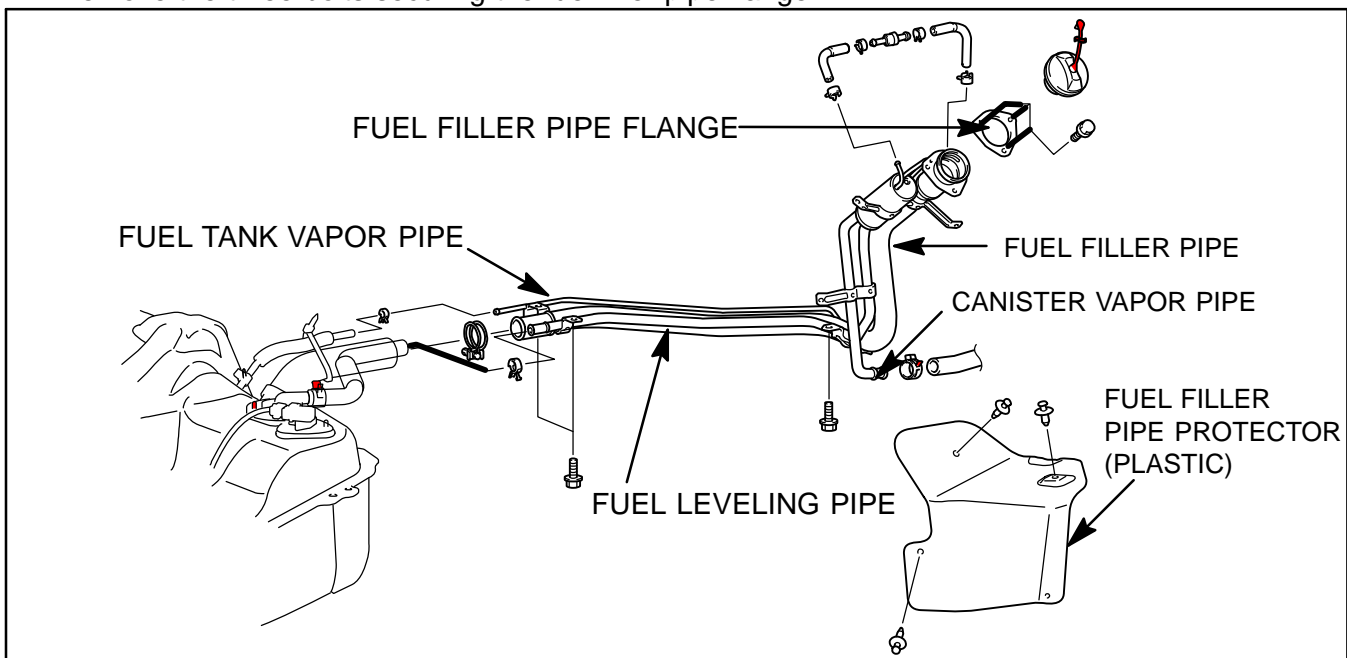



3. Apply masking tape around the fuel filler pipe opening to protect the paint.
4. Raise the vehicle on a lift.
5. Remove the left rear wheel and tire assembly.
6. Remove the plastic fuel filler pipe protector and the wheel splash shield in the left rear wheel well.

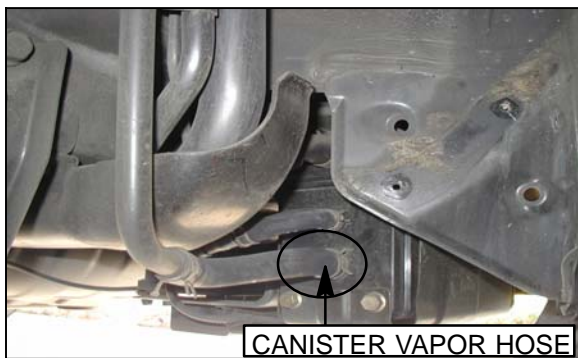

7. Remove the canister vapor hose at the canister.

**⚠ CAUTION**

**When removing hoses, use extreme care to prevent damaging the plastic connection.**

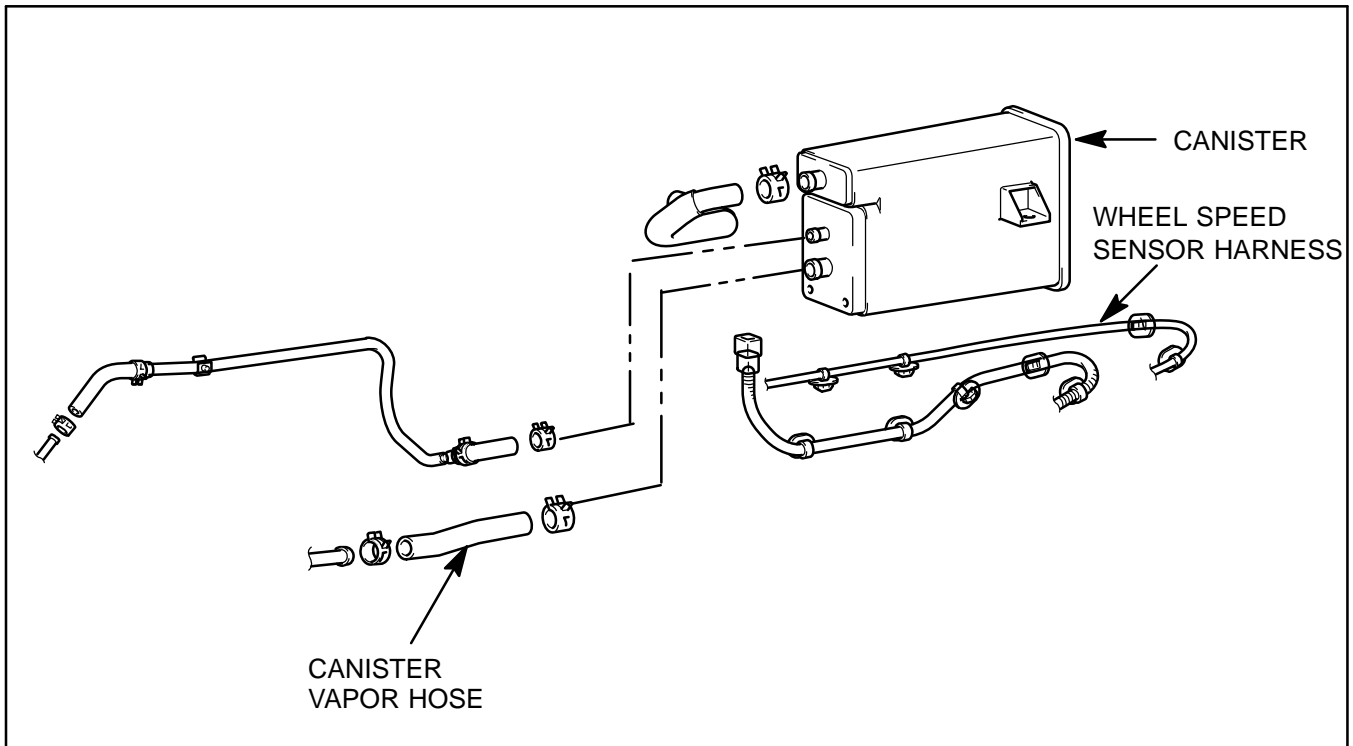

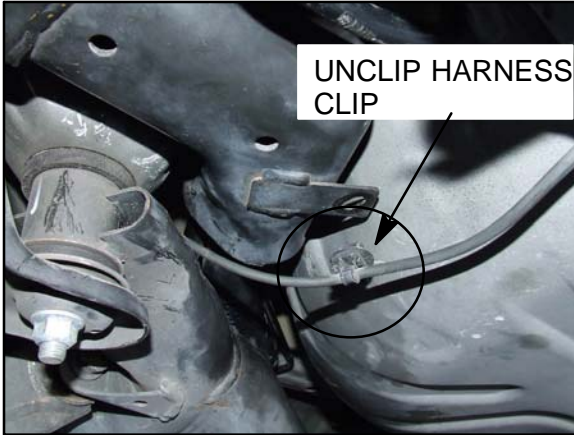

8. Unclip the wheel speed sensor harness clip at the fuel pipe protector. (The clip will remain on the harness.)

9. At the lower end of the fuel filler pipe, remove the hose clamps from the vapor hose, fuel filler hose, and fuel leveling valve hose. For ease of removal, split the hoses lengthwise, and remove the hoses.  
Discard the plastic hose band securing the vapor hose to the fuel filler hose.

10. Remove the fuel filler pipe assembly as follows:

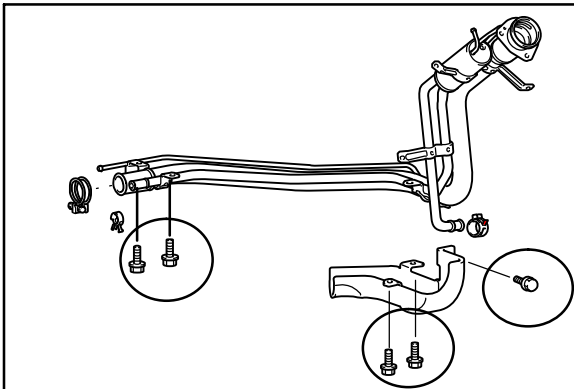

- a. Remove the 3 bolts securing the metal fuel filler pipe protector.
- b. Remove the 2 bolts securing the lower end of the fuel filler pipe to the vehicle body.

**To view a short video of the following procedure, click on this link:**  
[Link to video](#)  
**This video demonstrates only Steps 11c through 11g.**

- c. Remove the pipe from the fuel filler opening and lower the pipe down.
- d. Rotate the filler portion of the pipe assembly toward the front of the vehicle, to clear the crossmember.

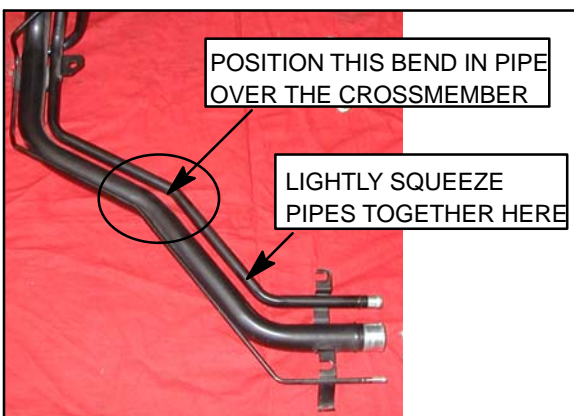

- e. Be sure the bend in the pipe (the area indicated in the figure at left) is positioned over the crossmember.
- f. On the pipe assembly, lightly squeeze the fuel leveling pipe and main inlet pipe together in the area indicated.
- g. Rotate the pipe assembly downward. Pull the pipe rearward and down from between the crossmember and the body.

11. Remove any excess rubber gasket material from the wheel well side of the fuel filler opening.

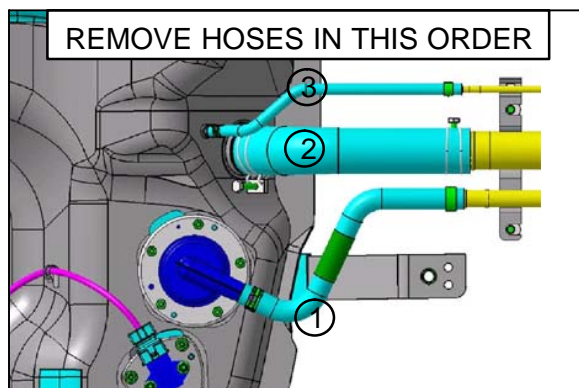

12. Remove the vapor hose, fuel filler hose, and fuel leveling valve hose from the fuel tank. For ease of removal, remove them in the order shown.

Split the hoses lengthwise, then remove them.

**CAUTION**

**When removing hoses, use extreme care to prevent damaging the plastic connection.**

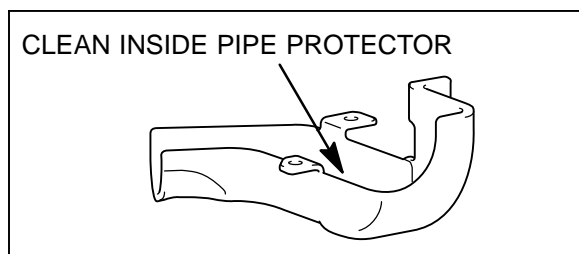

13. Clean any mud and debris from inside the metal fuel filler pipe protector, to clear the drain hole.

### **Fuel Filler Pipe Assembly Installation**



14. Attach the new hose clamps onto both ends of the new vapor hose, fuel filler hose, and fuel leveling valve hose provided in the repair kit.

- a. Install the new fuel filler hose clamp with the **BLACK** band at the **filler pipe**.

Install the new fuel filler hose clamp with the **BLUE** band at the **fuel tank**.

15. Install the three new hoses to the fuel tank in the order shown. Be sure the markings on the new hoses at the fuel tank are facing **UP**. Then reposition the clamps securely.

**NOTE: Isopropyl alcohol can be used as a lubricant during hose installation.**

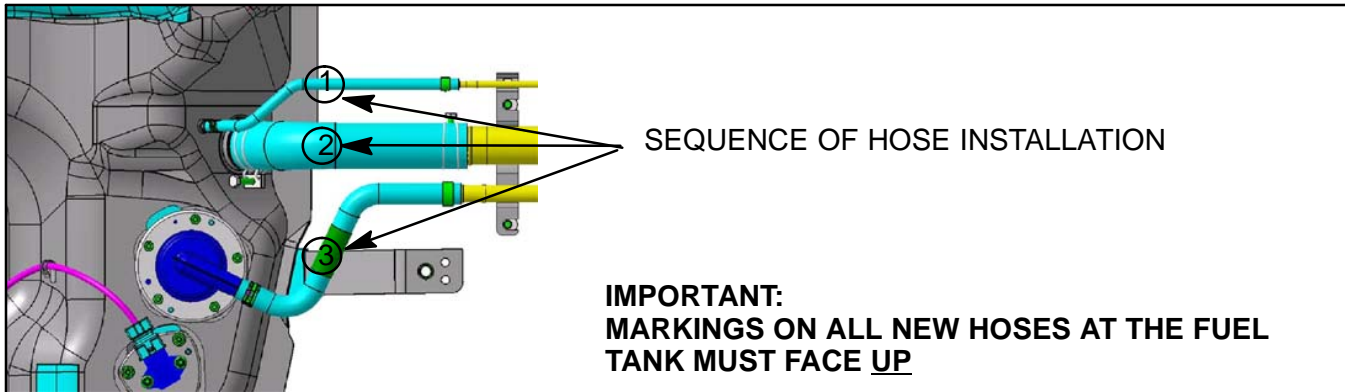

NOTE: The fuel tank vapor hose provided in the repair kit does not have a protective sheath like the original hose and does not need to be secured to the fuel filler hose.

**CAUTION**

To prevent damage, use care to avoid catching the pipe assembly bracket on any underbody components.

16. Install the new fuel filler pipe assembly and the metal fuel filler pipe protector.

**IMPORTANT:** Be sure the new rubber gasket is installed on the fuel filler end of the pipe.

- To prevent possible entry of foreign material, insert a clean shop rag into the filler opening of the new pipe.
- Reverse the pipe removal process (in Step 11) to align the pipe into position.

**IMPORTANT: The fuel filler pipe must be positioned ABOVE the wheel speed sensor harness.**

- Loosely install the 2 bolts to secure the lower end of the pipe to the vehicle body.
- Loosely install the 3 bolts to secure the metal fuel filler pipe protector.
- Remove the shop rag from the pipe and remove the masking tape from the filler opening. Loosely install the 3 fuel filler pipe flange bolts.
- When the pipe assembly is properly aligned, torque all bolts.

17. Install the three new hoses to the fuel filler pipe assembly. Then tighten the hose clamps.

**NOTE: Isopropyl alcohol can be used as a lubricant during hose installation.**

18. Reattach the wheel speed harness cable clip.



19. Attach the new hose clamps onto the new canister vapor hose, and install the hose.
  - a. Be sure the hose marking is facing **DOWN**.
  - b. The larger end of the canister hose requires the larger clamp as shown. This end is installed at the canister.

20. Lower the vehicle and perform the following fuel/vapor leak check:

- a. Connect the MUT-III scan tool.
- b. Start the engine and allow to idle.
- c. Check for and record all DTCs in the MFI system.
- d. Erase all DTCs in the MFI system (regardless of a DTC being present). Cycle the ignition key to the OFF position, then restart the engine. This will reset the monitor readiness status and allow the Evap Leak Monitor to run.
- e. Using the MUT-III, run the Evap Leak Monitor:

**System Select --> MFI main screen --> Mitsubishi --> Emission Test --> Evap Leak Monitor**

Follow the on-screen instructions.

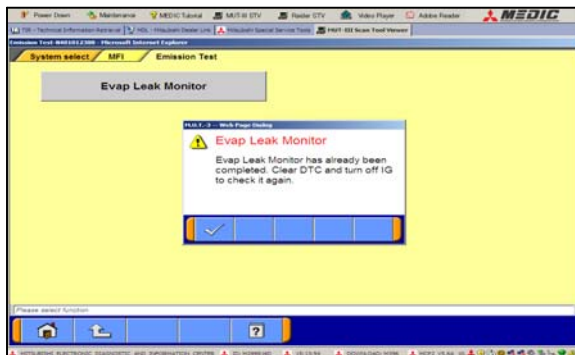

If the Evap Leak Monitor cannot be run because all readiness tests are completed, or a DTC is present, this screen will display. Clear the DTCs in the MFI system, cycle the ignition key to the OFF position, start the engine, and then run the Evap Leak Monitor again.

If any DTCs are detected in the MFI system, record them and refer to the service manual to diagnose the DTC. Additional diagnosis and repairs unrelated to the fuel filler neck replacement are not covered under this Safety Recall. Standard warranty procedures apply.

- f. If the Evap Leak Monitor runs successfully and no DTCs are detected, this test is complete. Go to Step 22.

21. Reinstall the rear wheel splash shield and the plastic fuel filler pipe protector.

22. Reinstall the rear wheel and tire assembly.

23. If any fuel was removed before starting this repair, return it to the vehicle.

### EVAPORATIVE EMISSIONS SYSTEM DIAGRAM

- G = Canister hose
- J = Fuel Leveling Hose
- K = Fuel Vapor Hose
- P = Fuel Filler Hose

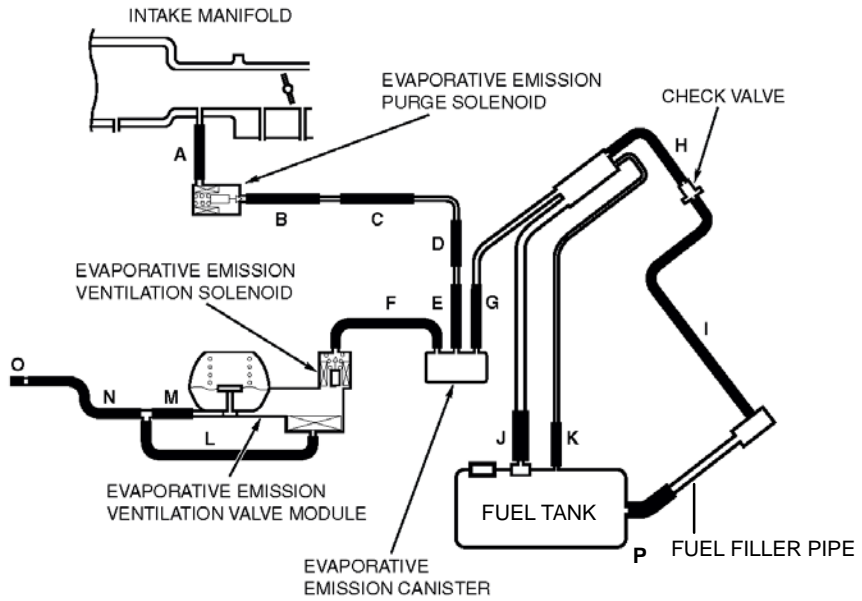

### PARTS INFORMATION

Use the genuine Mitsubishi Parts listed below:

Description	Part Number
<b>Fuel Filler Pipe Repair Kit</b> Kit contains: Fuel filler pipe assembly, fuel filler hose, fuel levelling valve hose, fuel tank vapor hose, canister vapor hose, and 8 hose clamps	MW400034

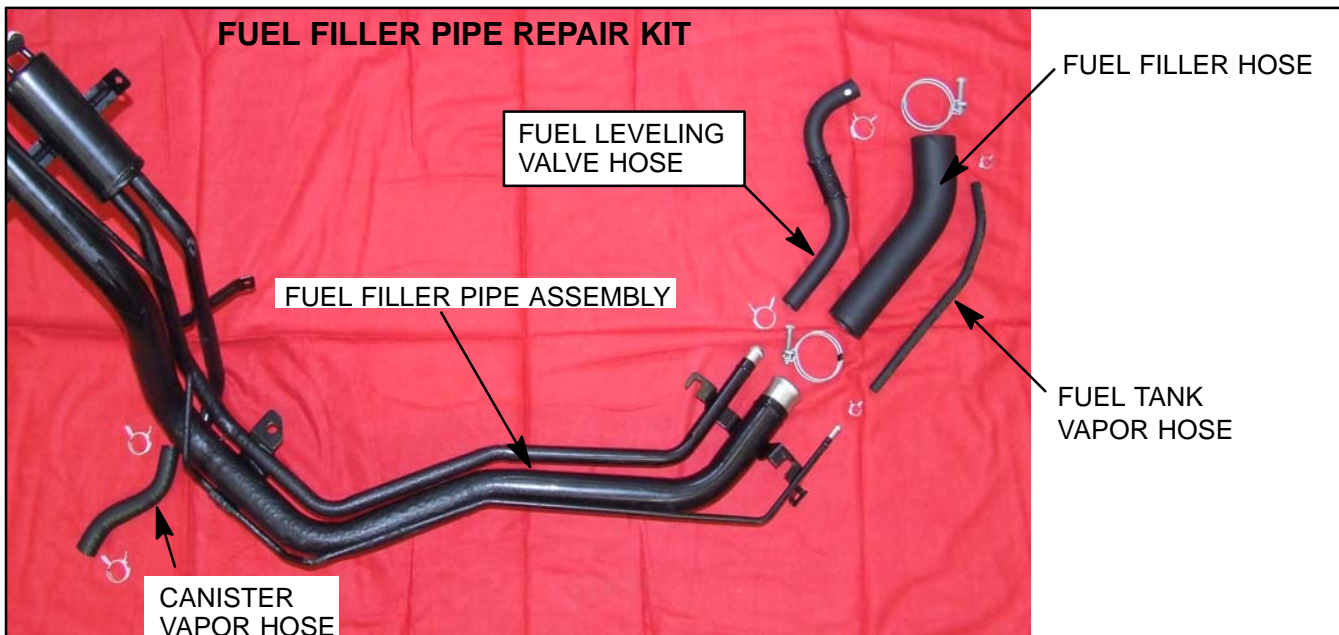

An initial supply of repair kits will be allocated to dealers in affected U.S. states. Determine your actual dealership needs before ordering additional kits by referring to the Open Campaign List on the MDL e-reports or contact your District Parts & Service Manager for assistance.



## WARRANTY INFORMATION

Enter all claims as Recall Claims.

Please follow the campaign claim examples shown on the following pages.

*Fuel Filler Pipe Replacement*  
*Campaign Labor Operation: C1002M02*  
*Labor Time: 1.3 hrs.*



***Replacement Parts Storage and Retention:***

**Retain all replaced fuel filler pipes and related parts for at least five (5) days after the payment of the related campaign claim.** The five days begins the day after the claim appears in the "PAID" section of your warranty claim statement. If the part is requested during those five days, you must return the part as indicated on the parts return request letter. If you do not receive a request after five days from the claim payment date, you may scrap the replaced pipe.

Copyright 2010, Mitsubishi Motors North America, Inc.

The information contained in this bulletin is subject to change. For the latest version of this document, go to the Mitsubishi Dealer Link, MEDIC, or the Mitsubishi Service Information website ([www.mitsubishitechinfo.com](http://www.mitsubishitechinfo.com)).

## Header Section 2004 Endeavor Fuel Filler Pipe Replacement

Service Warranty

Claim Entry
Vehicle Information
PQR/VQR

### Campaign Information

Campaign Operation No	C1002M__	<p>Enter in the first 6 characters of the campaign labor operation</p> <p>This campaign is for the certain 2004 Endeavor models operated in Canada, 38 listed states and D.C. (see chart on page 1 of this bulletin). Check the Open Recall area of the Superscreen each time to be certain of a vehicle's eligibility. Only VINS showing C1002M as open are involved.</p>	
Miles/Km			
VIN	4A.....		
Service Technician			
Emp No		Service Advisor	
Emp No		Emp No	
Spec Value *		Duplicate Recall *	<input type="checkbox"/>

Dealer: 99320 Ref No: VIN:

Claim No: Adj: Claim Status: Incomplete Model and Year:

**Note:** In some rare instances, it may be necessary to arrange towing an/or to provide a rental/loaner vehicle to a customer. Please use the entry fields at the bottom of the campaign claim's labor section.

Special Sublet Selection				
Select	Labor Operation	Labor Operation Description		Am
<input type="checkbox"/>	SHO	SPECIAL HANDLING ORDER	SHO Parts Order	
<input type="checkbox"/>	RENTACAR	RENTAL CAR CHARGES	Days <input type="text"/> Reason <input type="text" value="&lt;Select one&gt;"/>	
			Rental Company <input type="text"/> Invoice Number <input type="text"/>	
<input type="checkbox"/>	95300040	FREIGHT CHARGES	Freight Company <input type="text"/> Invoice Number <input type="text"/>	
<input type="checkbox"/>	95200040	TOWING CHARGES	Towing Company <input type="text"/> Invoice Number <input type="text"/>	

**PARTS SECTION: PARTS CLAIMED FOR FUEL PIPE REPLACEMENT**

MITSUBISHI DEALER LINK Recall Claim Help

Claim Entry Vehicle Information e-Reports DMS Interface PQR/VQR

Add Page - Parts Information

Delete	Part No	Part Description	Qty	Unit Price	Part Amount	Primary
	MW400034 ONLY		Qty = 1			
1.						
2.						
3.						
4.						
5.						
6.						
7.						

Check Part Prices Save & Continue More Parts Main Menu Cancel Changes

**LABOR SECTION: LABOR FOR FUEL PIPE REPLACEMENT**

MITSUBISHI DEALER LINK Recall Claim Help

Claim Entry Vehicle Information e-Reports DMS Interface PQR/VQR

Add Page - Labor Information

Note: These entries will automatically be filled in based on the campaign number you entered on the previous screen.

The allowed labor time for the repair is 1.3 hrs.

Delete	Sublet	Labor Code	Qty	Total Hrs	Labor Amt
		C1002M02	1	1.3	

Total Labor Amount

Update Finish PWA Main Menu Cancel Changes



AFFECTED VEHICLES  
MODELS: 2004 ENDEAVOR

Date: July, 2010

Dear Mitsubishi Owner,

This notice has been sent to you in accordance with the requirements of the National Traffic and Motor Vehicle Safety Act.

**Reason For Notice:** Mitsubishi Motors North America, Inc. (MMNA) has determined that a defect relating to vehicle safety exists in certain 2004 Endeavor vehicles being operated in locations where road salt is used and in cold conditions. Road salt can cause corrosion of the fuel filler pipe. Over time, corrosion could lead to fuel leakage from the pipe during fueling of the vehicle. Fuel in the presence of an ignition source may result in a potential fire hazard.

**What you should do:** Please contact your Authorized Mitsubishi Dealer and schedule an appointment to have the fuel filler pipe on your vehicle inspected. If necessary, the dealer will replace the fuel filler pipe, free of charge. When you bring your vehicle in, please show the dealer this letter. (If you misplace this letter, the dealer will still make this inspection/repair to your vehicle, free of charge). Please bring your vehicle to the dealership with less than ½ tank of fuel.

**What your dealer will do:** The dealership will inspect your vehicle to determine if it already has an improved fuel filler pipe with corrosion protection coating. If necessary, the dealer will install an improved fuel filler pipe on your vehicle.

**How long will it take?** The time needed for this repair is approximately 1½ hours. The dealer may need your vehicle for a longer period of time due to service scheduling issues, but every effort will be made to minimize your inconvenience.

If you experience any problem having your vehicle repaired promptly and/or at no charge, please inform us by calling the Mitsubishi Customer Relations Department at **888-648-7820**. Hours: Monday through Friday 7 a.m. to 4 p.m. (Pacific Time)

If, after contacting Mitsubishi Customer Relations, you still have a problem getting this repair made promptly and/or without charge, write to the Administrator, National Highway Traffic Safety Administration, 1200 New Jersey Avenue SE, Washington, D.C. 20590, or call the toll-free Vehicle Safety Hotline at 1-888-327-4236 (TTY: 1-800-424-9153), or go to <http://www.safercar.gov>.

If you have already encountered a problem regarding the above condition and have paid for the repair, you may send your original receipts and/or other adequate proof of payment to the following address for reimbursement:

Mitsubishi Customer Relations Department, P.O. Box 6400, Cypress, CA 90630-0064

**Notice to Lessors:** If you are a lessor of five or more leased vehicles as of the date of this letter, you have an obligation under federal law, (49 CFR Part 577), to provide each lessee of the above referenced vehicle with a copy of this letter by first class mail within ten days of receipt. Further, you must maintain a record which identifies each lessee to whom you sent a copy of this letter, the date you sent it, and the vehicle identification number (VIN) of the subject vehicle.

We appreciate your prompt attention to this matter.

Sincerely,

Mitsubishi Motors North America, Inc.

C1002M01