



# MODIFICATION INSTRUCTION

MI No. <b>853-2727</b>	Date <b>April 2010</b>	<b>9-3</b>
Distr. <b>US/CA/MX</b>		

## Check/Replacement of front seat belt, US/CA/MX

### Product Safety Campaign 150 26

Cars in stock must be rectified before delivery.  
A personal communication will be sent to the owners of cars already delivered requesting them to get in touch with the nearest Saab Authorized dealer as soon as possible to have the fault rectified.

### Cars affected

Saab 9-3 ( 9440), 4D M0 4 within VIN interval 41016380-41058122

### Background

The wire for the belt retractor may break. This may lead to the automatic belt rewinding not functioning.

### Important

The method described here differs from the corresponding method in Tis2Web.

### Symptom description

Automatic belt rewinding does not work.

### Parts required

12 760 074 Front seat belt (LH)

### If the bracket for the rear seat breaks when the rear seat is removed:

24 437 789 Mounting 2 pieces/car

(estimated defective production issue 15%-20%)

**Procedure**

**Note**

Only the left side is covered by this campaign

**Method of checking**

Is the seat belt on the left side marked with part number 12796393?

**No:** The seat belt should not be replaced.

**Yes:** Replace the seat belt on the left side.

**Method for changing the seat belt**

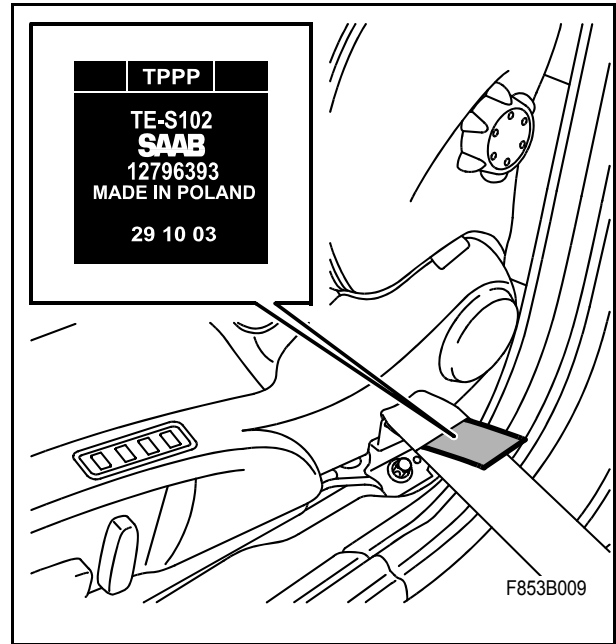

**WARNING**

Saab 9-3 has an airbag system as a standard that can include the belt tensioner as a component.

Work following the safety and handling guidelines described in Tis2Web group 8 - Airbag system - Technical description - Safety and handling guidelines

- 1 Set the ignition key to the LOCK position.
- 2 Remove the B-pillar trim as described in Tis2Web - Body - Interior - Repair instructions - B-pillar trim.

**WARNING**

The battery ground cable should be removed before the positive cable. Wait at least 1 minute after disconnecting the battery before starting any work on the airbag system. Otherwise, the airbag could be accidentally triggered, which could cause severe injury or even death.

- 3 Disconnect the battery.
- 4 Remove the seat belt guide.
- 5 Remove the strap guide. Make sure that the washer that lies between the strap guide and the vertical adjuster is in place.
- 6 Remove the upper and lower bolt of the inertia reel.
- 7 Remove the inertia reel and remove the belt tensioner connector.

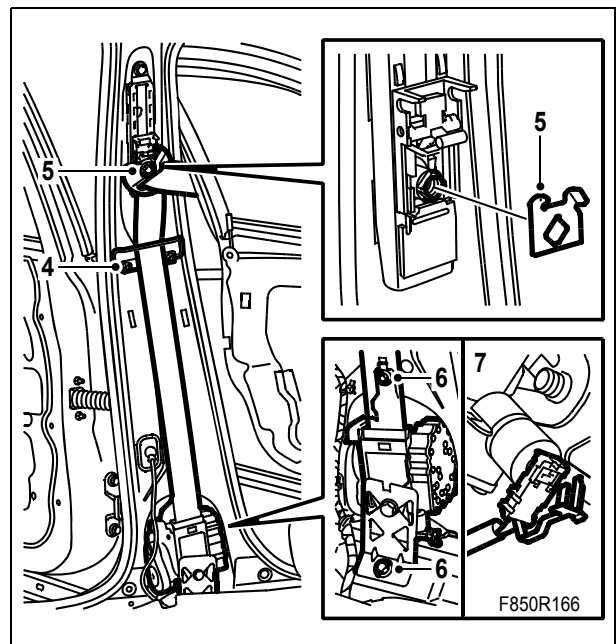

- 8 Plug in the connector of the new inertia reel. Be sure that the rear piece of the connector is pressed into place. Position the inertia reel. Insert the upper guide pin first.
- 9 Fit the upper and lower bolt of the inertia reel.  
**Tightening torque, lower bolt: 37 Nm ( 27 lbf ft)**
- 10 Fit the strap guide using a new bolt.

### Note

Note the position of the washer. The washer is marked with an R (right) or L (left) depending on which side is to be installed.

**Tightening torque: 37 Nm (27 lbf ft)**

- 11 Fit the seat belt guide.
- 12 Refit the B-pillar trim as described in Tis2Web - Body - Interior - Repair instructions - B-pillar trim.
- 13 Check seat belt function.
- 14 Connect the battery.
- 15 Then check with the diagnostic tool as follows:
  - Connect the diagnostic tool to the data link connector underneath the dashboard. Clear any diagnostic trouble codes.
  - Switch off the ignition and switch it on again. Wait at least 1 minute with the ignition key in the ON position. Check if any diagnostic trouble codes appear.
  - If a diagnostic trouble code appears: Perform the relevant fault tracing following the instructions for the trouble code.
  - If no diagnostic trouble code appears: Installation was successful. Disconnect the diagnostic tool.
- 16 Perform the procedure after battery disconnection as described in Tis2Web - Body - Airbag system - Repair instructions - Procedure after battery disconnection

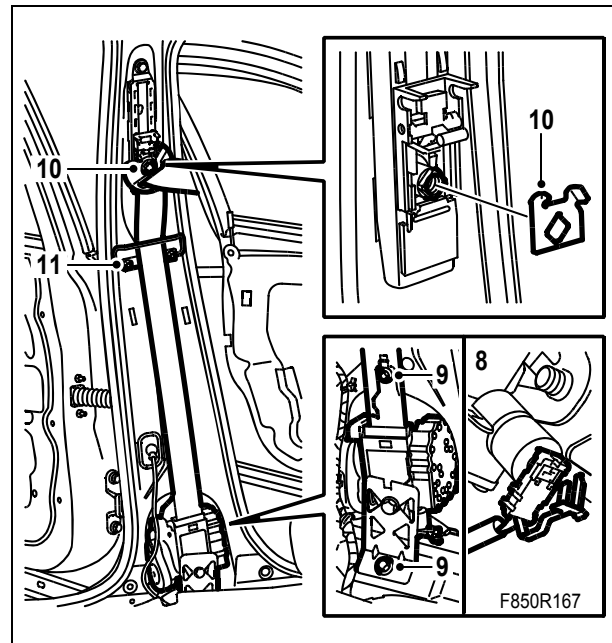

### Important

The replaced seat belts must be scrapped in accordance with local directives/legislation.

- 17 Scrap the belts as described in the following method.

## Scrapping, seat belts

 **WARNING**

The following points must be followed unconditionally when working on the airbag system:

- The belt tensioner activation unit is classified as a pyrotechnic part and is to be stored and handled in accordance with the laws and directives of the country you are in.
- All work must take place in accordance with the instructions given and carried out with caution. Risk of personal injury exists in the event of improper handling.
- Ear defenders must be worn when deploying the belt tensioner.
- The belt tensioners should never be exposed to temperatures above +100°C (212°F).
- Use protective eyewear and gloves when handling belt tensioners.
- The belt tensioner must not be treated with grease, cleaning agents or similar.
- The splicing of wiring in the airbag system is absolutely forbidden as this could cause malfunction that renders the system inoperable and can lead to serious or even fatal injury.

For reasons of safety and environmental protection, the pyrotechnic charge in the belt tensioner must be neutralised via electric priming as described below.

The belt tensioner is to be activated using 84 71 104 Cable with switch (B) and 86 12 434 Adapter cable, detonation device SRS (A).

### Note

The detonation device used consists of a 10 metre long two-wire cable with push button and battery clips as well as a connector for connection to the wiring harness. The wiring harness is replaced depending on which of the airbag system's components are to be scrapped. The battery to which the detonation device is connected must be in good condition.

- 1 Cut the belt to separate it from the height adjuster.

 **WARNING**

The belt must be absolutely clamped in place. Otherwise there is a risk that parts will come loose from the inertia reel upon activation. Risk of injury and property damage.

---

- 2 Pull out the belt enough to allow it to be clamped in place together with the inertia reel bracket in a vice as illustrated.

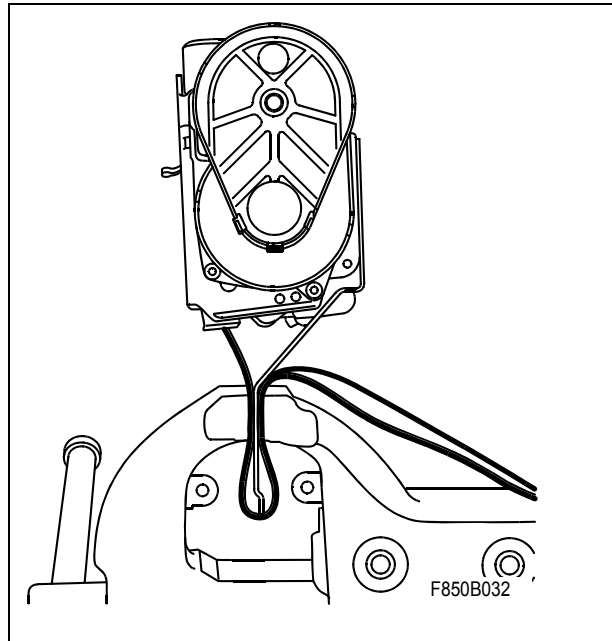

- 3 Connect 86 12 434 Adapter cable, detonation device SRS to the belt tensioner. Make sure that the secondary lock of the connector is locked.
- 4 Connect the detonation device 84 71 104 Cable with switch to the wiring harness.
- 5 Check that the belt is properly secured in the vice and that the belt is completely retracted.

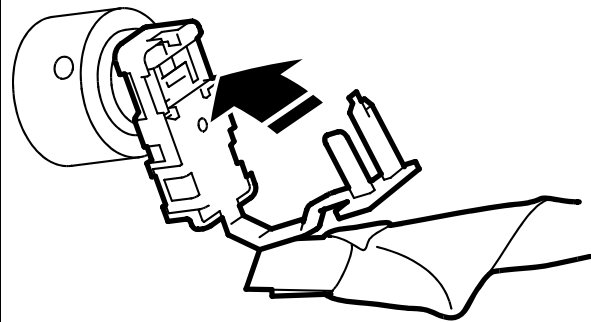

- 6 Place a battery 10 metres from the vice. Connect the detonation device to the battery.
- 7 Check that no one is within 10 metres of the vice.
- 8 Stand outside of the safety zone and press the switch. A bang will be heard when the belt tensioner is deployed.

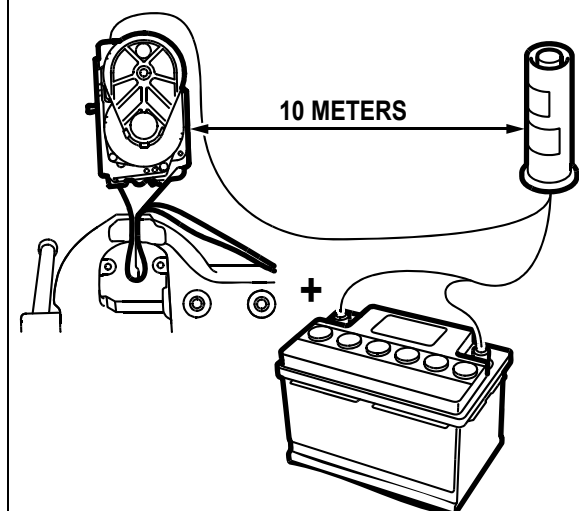

**⚠ WARNING**

If the belt tensioner does not deploy on the first attempt, disconnect the detonation device from the battery and examine the wires and battery thoroughly.

Under no circumstances may parts included in the airbag system be removed from one car to be used in another car.

- 9 Disconnect the detonation device wires from the battery immediately after the belt tensioner has been deployed.



**WARNING**

Take care when removing the connector from the belt tensioner gas generator as it could be warm.

- 10 Remove the connector from the belt tensioner gas generator.

### **Warranty/Time Information**

See separate information.

---