



# Recall Bulletin



## PRODUCT SAFETY RECALL

**SUBJECT:** Accelerator Pedal Sticking

**MODELS:** 2009-2010 Pontiac Vibe

### CONDITION

Toyota has decided that a defect, which relates to motor vehicle safety, exists in **all** 2009 and 2010 model year Pontiac Vibe vehicles. The Pontiac Vibe was manufactured by New United Motor Manufacturing, Inc. (NUMMI), a joint venture between Toyota and GM.

In these vehicles, there is a possibility that certain accelerator pedal mechanisms may mechanically stick in a partially depressed position or return slowly to the idle position. Over time, the internal mechanisms in the accelerator pedal may become worn. As a result of this wear, combined with certain operating and environmental conditions, friction in the mechanism may increase and intermittently result in the accelerator pedal being hard to depress and/or slow to return or, in the worst case, stick in a partially open position, increasing the risk of a crash, serious injury, or death.

### CORRECTION

Dealers are to install a precision-cut steel reinforcement bar into the accelerator pedal assembly, which will increase the clearance between the internal mechanisms in the accelerator pedal assembly. This increased clearance will reduce the friction caused by wear and environmental conditions, and allow the pedal to operate smoothly for the life of the vehicle.

### VEHICLES INVOLVED

Involved are **all** 2009 and 2010 model year Pontiac Vibe vehicles built within these VIN breakpoints:

Year	Division	Model	From	Through
2009	Pontiac	Vibe	9Z400001	9Z478598
2010	Pontiac	Vibe	AZ400001	AZ420785

**Important:** Dealers are to confirm vehicle eligibility prior to beginning repairs by using GMVIS (dealers using WINS) or the Investigate Vehicle History link (dealers using GWM). Not all vehicles within the above breakpoints may be involved.

For dealers with involved vehicles, a listing with involved vehicles containing the complete vehicle identification number, customer name, and address information has been prepared and will be provided to US and Canadian dealers through the GM GlobalConnect Recall Reports. Dealers will not have a report available if they have no involved vehicles currently assigned.

The listing may contain customer names and addresses obtained from Motor Vehicle Registration Records. The use of such motor vehicle registration data for any purpose other than follow-up necessary to complete this recall is a violation of law in several states/provinces/countries. Accordingly, you are urged to limit the use of this report to the follow-up necessary to complete this recall.

### PARTS INFORMATION

**Important:** An initial supply of reinforcement bars required to complete this recall will be pre-shipped to involved dealers of record in the U.S. and in Canada. Due to limited allocation of inventory authorized by Toyota, GM dealers will receive pre-shipments that consist of a good variety of pieces and sizes (part numbers) sufficient to begin repairing vehicles immediately. GMSP0 will be sending multiple pre-shipments to involved dealers of record during the weeks of February 8 and February 15, 2010, as more inventory becomes available. These pre-shipments will be delivered to U.S. and Canadian dealers via FEDERAL EXPRESS OVN from the SPO Lansing PDC, as 'freight pre-paid'.

After February 19, if additional parts are still required, dealers should order from General Motors Service and Parts Operations (GMSP0), or attempt to get from another nearby GM dealership if they have excess of the size (part number) that you need. Please refer to your "involved vehicles listing" before ordering parts. It is recommended that any additional orders be placed as CSO3 = Customer Special Order-OVN. These seven part numbers will not be eligible for RIM Management, however dealer inventory will be monitored to encourage dealers to share inventory to get vehicles repaired.

**Important: INSTALL THE CORRECT REINFORCEMENT BAR ONLY - DO NOT SUBSTITUTE REINFORCEMENT BARS. REFER TO STEP 6 IN THE SERVICE PROCEDURE FOR PROPER MEASURING TO DETERMINE APPLICABLE REINFORCEMENT SIZE.**

Part Number	Description	Quantity/Vehicle
89027390	Reinforcement, Accel Ped Lvr Supt (1.40 mm thickness)	1 (If Req'd)
89027391	Reinforcement, Accel Ped Lvr Supt (1.60 mm thickness)	1 (If Req'd)
89027392	Reinforcement, Accel Ped Lvr Supt (1.80 mm thickness)	1 (If Req'd)
89027393	Reinforcement, Accel Ped Lvr Supt (2.00 mm thickness)	1 (If Req'd)
89027394	Reinforcement, Accel Ped Lvr Supt (2.30 mm thickness)	1 (If Req'd)
89027395	Reinforcement, Accel Ped Lvr Supt (2.60 mm thickness)	1 (If Req'd)
89027396	Reinforcement, Accel Ped Lvr Supt (2.90 mm thickness)	1 (If Req'd)

SERVICE PROCEDURE

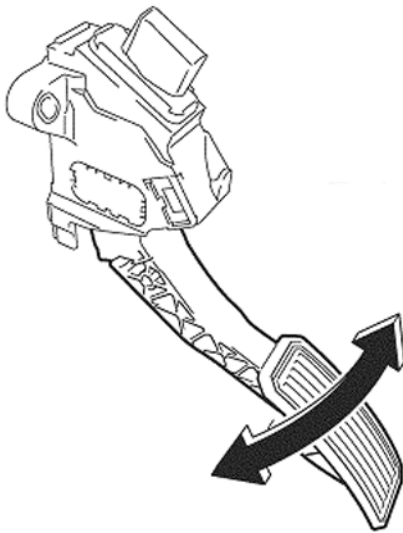

2394596

1. Pump the accelerator pedal 10 times in a full stroke.

**Caution:**

- Do not drop the accelerator pedal. Do not reuse an accelerator pedal that has been dropped.
- Avoid vibration and shock to the accelerator pedal.

**Note:** For additional information on accelerator pedal removal, refer to SI.

2. Remove the accelerator pedal assembly.
  - 2.1. Disconnect the accelerator pedal electrical connector.
  - 2.2. Remove the 2 bolts.

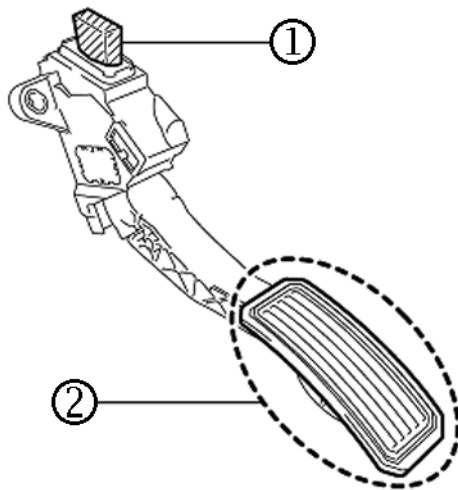

2394604

**(1) Connector (2) Area of accelerator to Clean**

3. Protect the accelerator pedal electrical connector (1) using UL listed electrical tape.

**Caution:** Do not use compressed air to clean the accelerator assembly; this may force dirt and debris into the sensor area.

4. Clean the accelerator pedal assembly with water and shop towel. Refer to the illustration to view the area of the accelerator pedal to clean.

**Caution:** Do not twist, bend or discard the accelerator link arm support cover; it will need to be reinstalled.

**Caution:** Do not clean out any debris caused by wear; this may trap debris in the pedal causing future malfunctions.

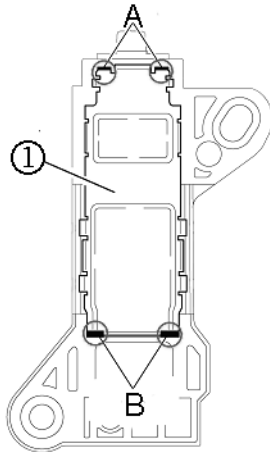

2394601

**View: Back-side of Pedal Assembly (1) Accelerator Link Arm Support Cover (A) Gaps (B) Gaps**

5. Remove the accelerator link arm support cover using a pocket screwdriver. Evenly and lightly pry up on gaps (A) and then gaps (B) to remove the cover. Refer to illustration.

**Note:** Dealer in-stock and lower mileage vehicles may have a clearance greater than 2.3 mm and less than 2.7 mm. USE the 2.9 mm thickness reinforcement bar for clearances between 2.3 mm and 2.7 mm.

**Note:** If the clearance between the stopper and housing is greater than 2.7 mm, contact the Technical Assistance Center.

6. Determine the reinforcement bar thickness.

**Note:** Mark the feeler gauge 10 mm from the edge to aid in measurement.

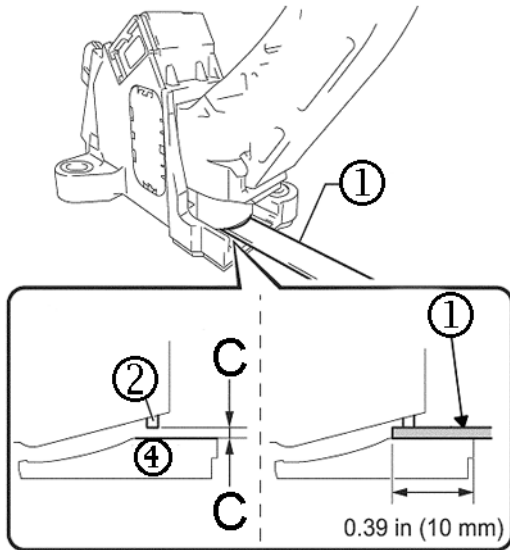

2394592

**(1) Feeler Gauge (C) Clearance (2) Stopper (4) Housing**

- 6.1. Using a feeler gauge (1), measure the clearance (C) between the stopper (2) and the housing (4).
- 6.2. Only insert the feeler gauge 10 mm from the end of the housing as illustrated.
- 6.3. Based on the measurement from Step 6.1, select the correct reinforcement bar using the table below.

Clearance	Reinforcement Bar	
	Thickness	Stamping
0.0 mm – 0.29 mm	1.4 mm	1.4 A
0.3 mm – 0.59 mm	1.6 mm	1.6 B
0.6 mm – 0.79 mm	1.8 mm	1.8 C
0.8 mm – 1.09 mm	2.0 mm	2.0 D
1.1 mm – 1.49 mm	2.3 mm	2.3 E
1.5 mm – 1.89 mm	2.6 mm	2.6 F
1.9 mm – 2.70 mm	2.9 mm	2.9 G
greater than 2.70 mm	Contact the Technical Assistance Center	

**Caution:** Never stack multiple reinforcement bars between the friction lever and the housing of the pedal assembly.

7. Install the reinforcement bar.

**Note:** Do not push more than necessary; it may deform the housing.

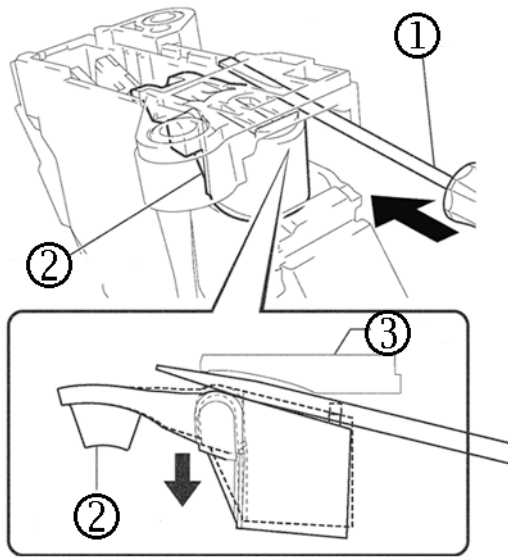

2394597

**Note:** Do not add any lubricants or chemicals to assist with the installation of the reinforcement bar.

- 7.1. Insert a clean thin-bladed flathead screwdriver (1) between the housing (3) and the friction lever (2) until the friction lever lowers.

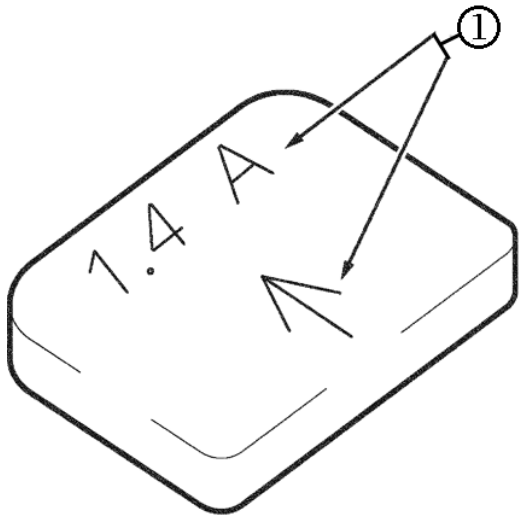

2394593

**Note:** As illustrated, insert the reinforcement bar with its stamped arrow (1) facing up.

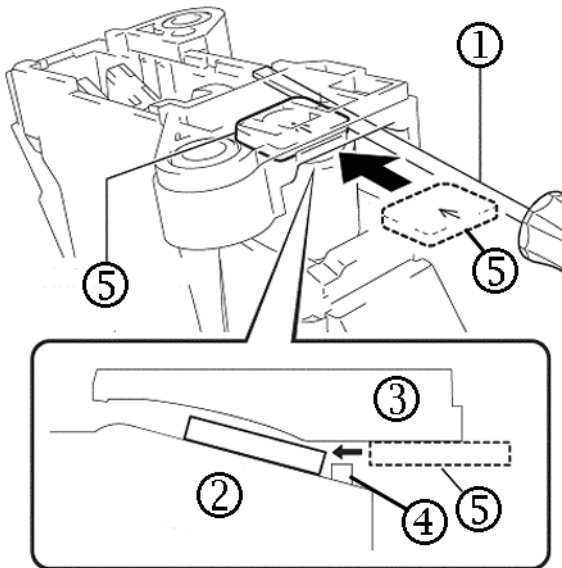

2394598

7.2. With the increased clearance between the friction lever (2) and the housing (3), insert the reinforcement bar (5) selected from Step 6.3.

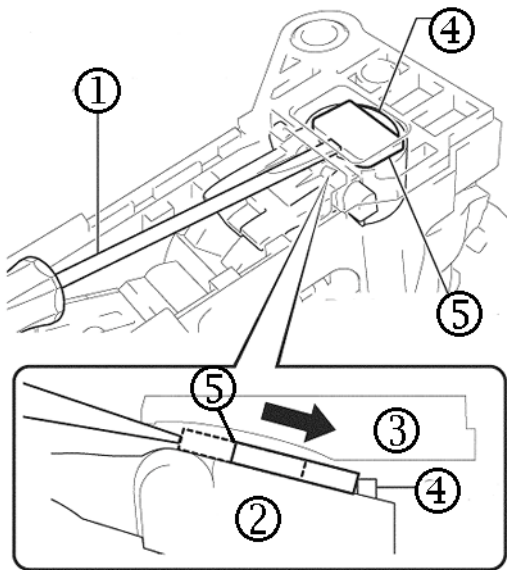

2394600

- 7.3. From the back of the pedal, firmly push the reinforcement bar (5) until it contacts the stopper (4).
- 7.4. Carefully center the reinforcement bar behind the stopper using a pocket screwdriver.

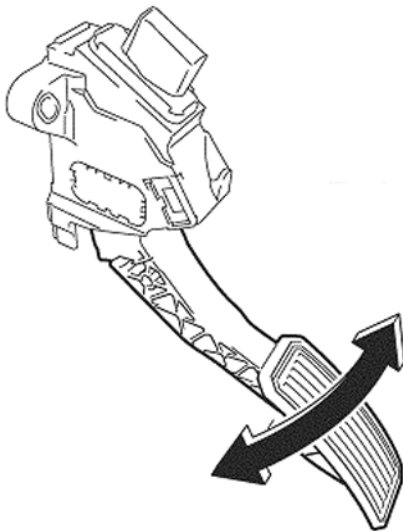

2394596

- 7.5. Pump the accelerator pedal 5 times in a full stroke to properly seat the reinforcement bar.



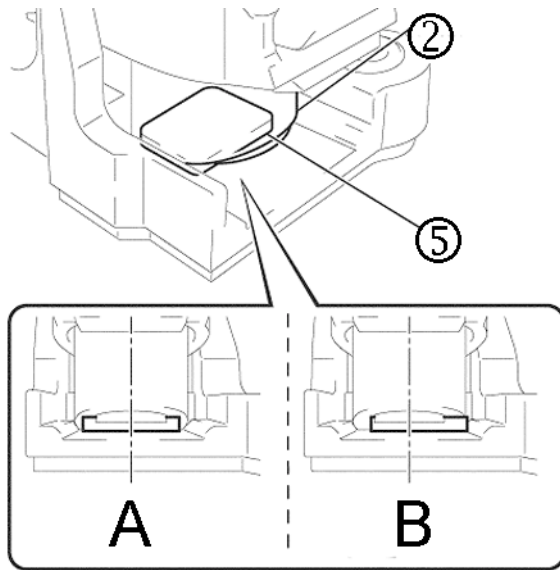

2394603

(A) OK (Centered) (B) Not OK (Not Centered)

8. Verify that the reinforcement bar (5) is properly centered (A) and flush with the stopper.

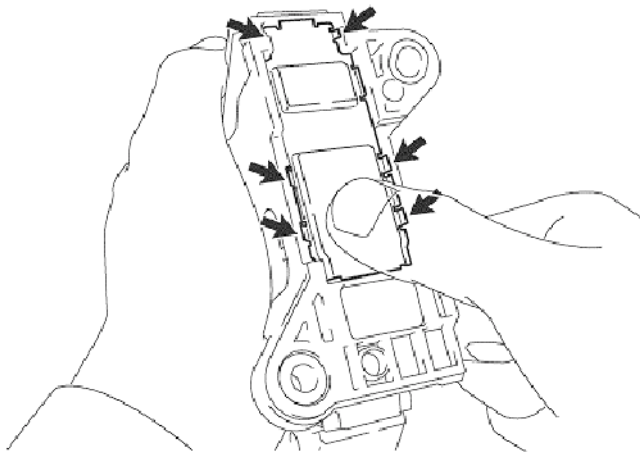

2394602

9. Install the accelerator link arm support cover.
  - 9.1. Repair any bent claws on the accelerator link arm support cover.
  - 9.2. Press down on the 6 claws to firmly install the accelerator link arm support cover.
10. Reinstall the accelerator pedal assembly.

**Note:** For additional information on accelerator pedal installation, refer to SI.

- 10.1. Remove the tape from the electrical connector.
- 10.2. Reinstall the pedal with the 2 bolts.
- 10.3. Torque to 5.5 N·m (49 in lb).
- 10.4. Reconnect the accelerator pedal connector.

11. Take out any removable (carpeted, all-weather, or other) driver's floor mat from the vehicle and place it in the trunk of the vehicle until the Floor Mat Interference and Accelerator Pedal recall (10038) remedy is ready and implemented on the vehicle. Notify the customer that the floor mat should remain in the trunk until recall 10038 has been performed.
12. Inspect the accelerator pedal assembly operation.
  - 12.1. Connect the Tech 2<sup>®</sup>.
  - 12.2. Check for diagnostic trouble codes (DTCs). If DTCs are displayed, verify the code(s) and record the freeze frame data, and then perform repairs as necessary.

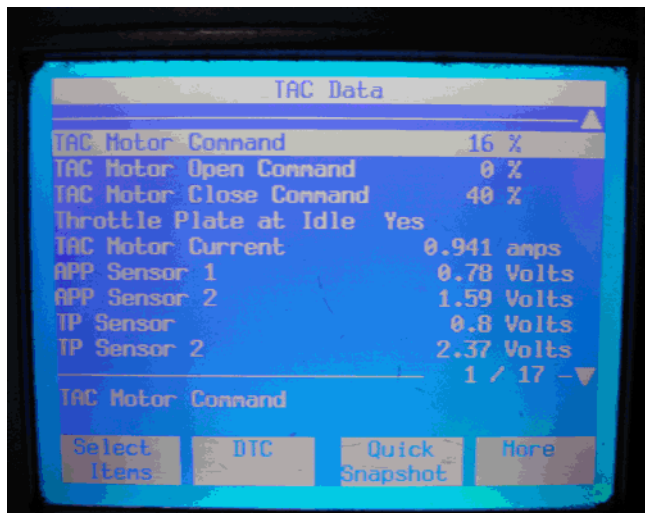

2394591

- 12.3. From the Main Menu of the Tech 2, select Diagnostics>Year>Passenger Car>Division>Model>Powertrain>Transmission Selection>Engine Selection>ECM>Data Display> TAC Data. The TAC Data screen provides voltage information for the Accel Sensor Out No.1 and Accel Sensor Out No.2.
- 12.4. Check the values by referring to the table below.

Tester Display	Measurement: Range (Display)	Normal Condition	Diagnostic Note
Accel Sensor Out No. 1	APP Sensor No. 1 Voltage	Accelerator Pedal Released: 0.5 to 1.1 V	Read value with ignition switch to ON (Do not start engine)
		Accelerator Pedal Fully Depressed: 2.6 to 4.5 V	
Accel Sensor Out No. 2	APP Sensor No. 2 Voltage	Accelerator Pedal Released: 1.2 to 2.0 V	Read value with ignition switch to ON (Do not start engine)

**COURTESY TRANSPORTATION**

The General Motors Courtesy Transportation program is intended to minimize customer inconvenience when a vehicle requires a repair that is covered by the New Vehicle Limited Warranties. The availability of courtesy transportation to customers whose vehicles are within the warranty coverage period and involved in a product program is very important in maintaining customer satisfaction. Dealers are to ensure that these customers understand that shuttle service or some other form of courtesy transportation is available and will be provided at no charge. Dealers should refer to the General Motors Service Policies and Procedures Manual for Courtesy Transportation guidelines.

CLAIM INFORMATION

1. Submit a claim using the table below.
2. Courtesy Transportation - For dealers using WINS, submit using the labor code shown below; for dealers using GWM – submit as Net Item under the repair labor code.

Labor Code	Description	Labor Time	Net Item
V2204	Accelerator Pedal Repair Reinforcement Bar	0.7	*
V2206	Courtesy Transportation (Dealers using WINS only)	N/A	**

- \* **For vehicles in dealer inventory only – This is NOT for customer vehicles.** The amount identified in "Net Item" (WINS) or "Misc Net Item" (GWM) should represent the product of the vehicle's average daily interest rate (see table below) multiplied by the actual number of days **the vehicle was in dealer inventory and not available for sale**. This reimbursement is limited to the number of days from the date of the stop delivery message (January 27, 2010) to the date the repair is completed and the vehicle is ready for sale (not to exceed 16 days):

Vehicle	US Reimbursement Amount	Canadian Reimbursement Amount
2009-2010 Pontiac Vibe	\$ 2.33	\$2.30

- \*\* **For dealers using WINS only:** The amount identified in "Net Item" should represent the actual dollar amount for courtesy transportation. Dealers using GWM, submit in "Net Item" under the repair labor code.

CUSTOMER NOTIFICATION

General Motors will notify customers of this recall on their vehicle (see copy of customer letter included with this bulletin).

DEALER RECALL RESPONSIBILITY – For US (US States, Territories, and Possessions)

The US National Traffic and Motor Vehicle Safety Act provides that each vehicle that is subject to a recall of this type must be adequately repaired within a reasonable time after the customer has tendered it for repair. A failure to repair within sixty days after tender of a vehicle is prima facie evidence of failure to repair within a reasonable time. If the condition is not adequately repaired within a reasonable time, the customer may be entitled to an identical or reasonably equivalent vehicle at no charge or to a refund of the purchase price less a reasonable allowance for depreciation. To avoid having to provide these burdensome remedies, every effort must be made to promptly schedule an appointment with each customer and to repair their vehicle as soon as possible. In the recall notification letters, customers are told how to contact the US National Highway Traffic Safety Administration if the recall is not completed within a reasonable time.

## DEALER RECALL RESPONSIBILITY – All

All unsold new vehicles in dealers' possession and subject to this recall must be held and inspected/repaired per the service procedure of this recall bulletin before customers take possession of these vehicles.

Dealers are to service all vehicles subject to this recall at no charge to customers, regardless of mileage, age of vehicle, or ownership, from this time forward.

Customers who have recently purchased vehicles sold from your vehicle inventory, and for which there is no customer information indicated on the dealer listing, are to be contacted by the dealer. Arrangements are to be made to make the required correction according to the instructions contained in this bulletin. A copy of the customer letter is provided in this bulletin for your use in contacting customers. Recall follow-up cards should not be used for this purpose, since the customer may not as yet have received the notification letter.

In summary, whenever a vehicle subject to this recall enters your vehicle inventory, or is in your dealership for service in the future, you must take the steps necessary to be sure the recall correction has been made before selling or releasing the vehicle.



February 2010

Dear General Motors Customer:

This notice is sent to you in accordance with the requirements of the National Traffic and Motor Vehicle Safety Act.

The Pontiac Vibe was manufactured by New United Motor Manufacturing, Inc. (NUMMI), a joint venture between Toyota and GM.

Toyota has decided that two safety defects that relate to motor vehicle safety exist in all 2009 and 2010 model year Pontiac Vibe vehicles. As a result, GM is conducting two safety recalls on your vehicle. We apologize for this inconvenience. However, we are concerned about your safety and continued satisfaction with our products.

**I M P O R T A N T**

- Your Pontiac Vibe is involved in safety recalls 10018 and 10038.

**Why is your vehicle being recalled?**

**Recall 10018: Accelerator Pedal Sticking:**

There is a possibility that certain accelerator pedal mechanisms may mechanically stick in a partially depressed position or return slowly to the idle position. Over time, the internal mechanisms in the accelerator pedal may become worn. As a result of this wear, combined with certain operating and environmental conditions, friction in the mechanism may increase and intermittently result in the accelerator pedal being hard to depress and/or slow to return or, in the worst case, stick in a partially open position, increasing the risk of a crash, serious injury, or death.

**Recall 10038: Floor Mat Interference and Accelerator Pedal:**

There is the potential for an unsecured or incompatible driver's floor mat to interfere with the accelerator pedal and cause it to get stuck in the wide-open position. A stuck open accelerator pedal may result in very high vehicle speeds and make it difficult to stop the vehicle, which could cause a crash, serious injury, or death.

**What will we do?**

**Recall 10018: Accelerator Pedal Sticking:**

Any authorized GM dealer will install a precision-cut steel reinforcement bar into the accelerator pedal assembly, which will increase the clearance between the internal mechanisms in the accelerator pedal assembly. This increased clearance will reduce the friction caused by wear and environmental conditions, and allow the pedal to operate smoothly for the life of the vehicle. The safety recall remedy will be performed for you at no charge.

**Recall 10038: Floor Mat Interference and Accelerator Pedal:**

GM will notify you again as soon as a recall remedy is available for your vehicle.

**What should you do?**

**These are two important Safety Recalls.**

**Recall 10018: Accelerator Pedal Sticking:**

Please contact your Pontiac dealer after February 22, 2010, to install the precision-cut steel reinforcement bar into the accelerator pedal assembly. You can go to [www.pontiac.com](http://www.pontiac.com) for the location of the nearest Pontiac dealership or you can go to any other GM dealership for this repair. The installation will take approximately 30 minutes. However, depending upon the dealer's work schedule and the inspection results, it may be necessary for you to make your vehicle available for a longer period of time.

**Recall 10038: Floor Mat Interference and Accelerator Pedal:**

GM requests that you take out **any removable** (carpeted, all-weather, or other) driver's floor mat and NOT replace it with any other floor mat, and place it in the trunk until the Floor Mat Interference and Accelerator Pedal recall remedy (which you will be notified of in the future) is ready and implemented on your vehicle.

In the event that you choose not to take out your removable floor mat, General Motors strongly recommends that you use only floor mats designed specifically for the model and model year of your vehicle, and that it is properly installed and secured. DO NOT use a mat that is flipped over with the bottom-side up, and DO NOT stack one floor mat over another. In addition, check the operation of the accelerator, brake, and clutch (if applicable) pedals to assure that the floor mat does not interfere with them.

**What should you do if you experience unintended acceleration?**

If you experience a condition while driving in which the vehicle continues to accelerate rapidly after releasing the accelerator pedal, this could be an indication of floor mat interference or a sticking accelerator pedal. If this occurs, GM recommends that you take the following actions:

- If possible and safe to do so, pull back the floor mat and dislodge it from the accelerator pedal; then pull over and stop the vehicle.
- If the floor mat cannot be dislodged, or if no floor mat is present, then firmly and steadily step on the brake pedal with both feet. Do not pump the brakes repeatedly because that may deplete vacuum assist, requiring increased brake pedal force.
- The engine can also be disabled by shifting the transmission to Neutral. After shifting to Neutral, firmly apply the brakes and steer the vehicle to a safe location on the side of the road; come to a complete stop, shift to Park, and turn the ignition key OFF.
- Call your dealer to pick up the vehicle. Do not drive it.

If you are unable to put the vehicle in Neutral, turn the ignition key to OFF, or to ACC position. This will not cause loss of steering or braking control, but the power assist to these systems will be lost. Do NOT remove the key from the ignition as this will lock the steering wheel.

**Do you have questions?**

If you have questions or concerns that your dealer is unable to resolve, please contact the Pontiac Customer Assistance Center.

**General Motors will advise you in a separate letter when a recall remedy is available for your vehicle regarding Recall 10038: Floor Mat Interference and Accelerator Pedal.**

If after contacting your dealer and the Customer Assistance Center, you are still not satisfied we have done our best to remedy this condition without charge and within a reasonable time, you may wish to write the Administrator, National Highway Traffic Safety Administration, 1200 New Jersey Avenue, SE., Washington, DC 20590, or call the toll-free Vehicle Safety Hotline at 1.888.327.4236 (TTY 1.800.424.9153), or go to <http://www.safercar.gov>.

Federal regulation requires that any vehicle lessor receiving this recall notice must forward a copy of this notice to the lessee within ten days.

Scott Lawson  
Director,  
Customer and Relationship Services