



210 Inverness Center Drive
Birmingham, AL 35242

Telephone: 205-991-7733
Facsimile: 205-991-9993
www.altec.com

October 25, 2010

Dear Owner,

This notice is sent to you in accordance with the requirements of the National Traffic and Motor Vehicle Safety Act.

Altec Environmental Products (AEP) has decided that a defect which relates to motor vehicle safety exists in certain WC126, WC126A, WC166, and WC166A Chippers. This can, under certain conditions, possibly result in a cracked or failed chipper mounting frame or a damaged axle.

AEP will repair or replace the chipper frame and axle to correct this condition. This repair is covered by AEP's warranty policy.

In order to determine if your unit is affected by CSN 531, compare the model of your unit with the list of affected units as described on the CSN. AEP will be contacting you within the next 3 to 4 months to schedule the repair. If you have not been contacted within that time, you may contact AEP at 1-877-435-9258, to schedule the repair to be completed.

After contacting Altec Environmental Products, if you are still not able to have the safety defect remedied within a reasonable time, you may write to: Administrator, National Highway Traffic Safety Administration, 1200 New Jersey Avenue SE, Washington, DC 20590 or call 1-888-327-4236 (TTY: 1-800-424-9153) or go to <http://www.safercar.gov>.

If you have sold or retired the unit please call AEP at 1-877-435-9258 so the records may be changed.

If you have leased this equipment to another person or company, you are required by Federal Law to forward a copy of this notice to the lessee by first class mail within ten (10) days of the receipt of this notice.

We are sorry to cause this inconvenience; however we are taking this action in the interest of your safety and continued satisfaction with AEP products.

Thank you for your immediate attention on this important matter.



Customer Service Notice

Date: October 25, 2010

Units Affected: WC126 and WC166 Chippers built after January 2008 and
All WC126A and WC166A Chippers

Frame and Axle Inspection

Some customers have reported cracks in the frame, frame failure or cracks in the axle attachment on the above listed chippers. The frame cracks have usually occurred just ahead of the axle mounting location on each side of the frame. The axle cracks have occurred in the axle mounting bracket.

While the areas where the cracks have occurred are listed in the Operator's Manual Periodic Inspection, Altec Environmental Products (AEP) requires that all the frames and axles on the listed chippers be inspected for cracks within thirty (30) days of the receipt of this CSN to determine the condition of the axle and frame. AEP will be contacting each customer within the next 3 to 4 months to schedule a repair of cracked frames or axles.

Use the following procedure for this inspection.

1. Position the chipper in a flat area where there is adequate light or an artificial light available to perform a careful inspection of the frame near the axle mounting (refer top Figure 1).

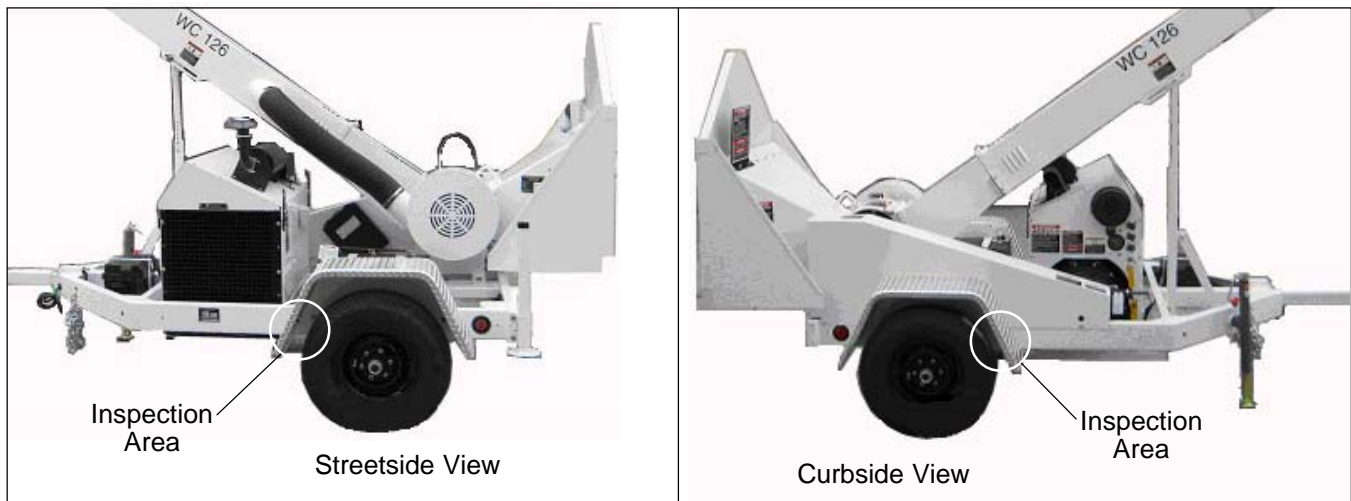

Figure 1 — Inspection Location

2. Look at each side of the frame in the area just in front of the axle mounting. Look for any cracks or deformities in this area of the frame close to the axle mounting brackets (refer to Figure 2).

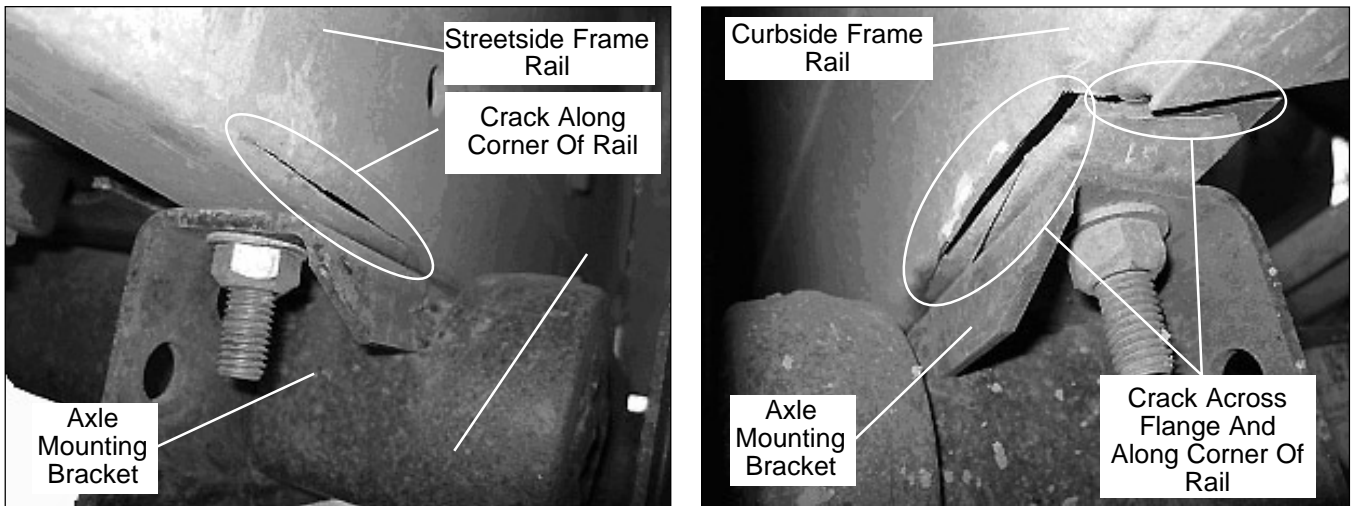

Figure 2 — Cracks Near The Axle Mounting

3. Inspect each axle mounting bracket for any cracks on where the bracket mounts to the axle (refer to Figure 3). Look for any deformation in the mounting bracket (bent ears, top of bracket bent, etc.)

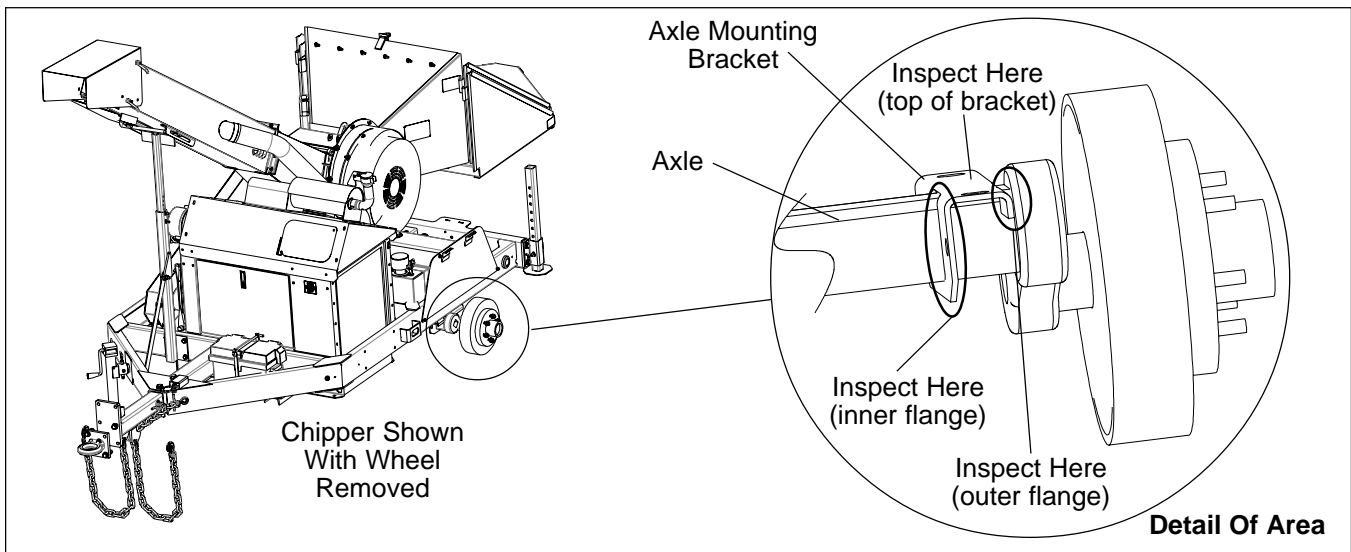

Figure 3 — Axle Mounting Inspection Area

4. If there is a crack in the axle mounting bracket, the crack can be welded **ONLY** if **ALL** of the following are true:
- the crack in the axle mounting is only in the smaller (outer) flange of the mounting and no longer than 1½ inches (refer to Figure 3).
 - cracks do not appear on the larger (inner) flange of the mounting.
 - the axle bracket is not deformed or cracked.

If all of the above conditions are true, weld the crack starting the weld beyond the crack. Wrap the weld around the bracket so that the weld ends on the inside surface of the u-shaped axle mounting bracket. Daily inspections of this area must continue until Altec has made the final repair. If the axle bracket is cracked on the inner flange, cracked more than 1½ inches, or deformed, remove the unit from service immediately.

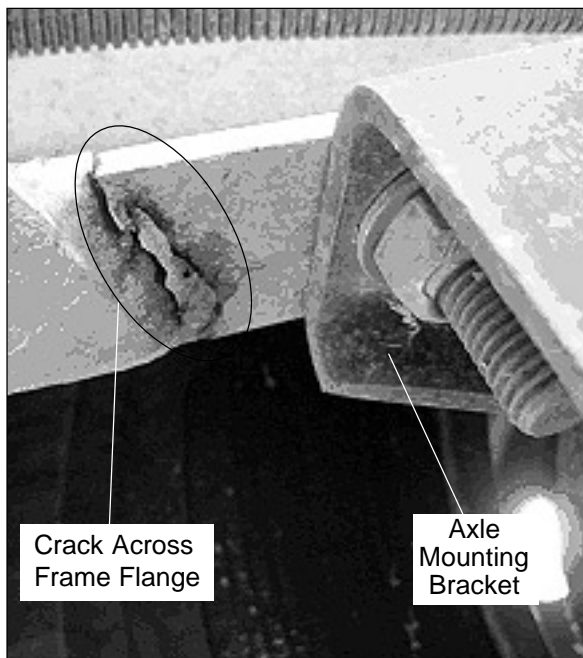

Figure 4 — Cracks Across The Bottom Of The Frame

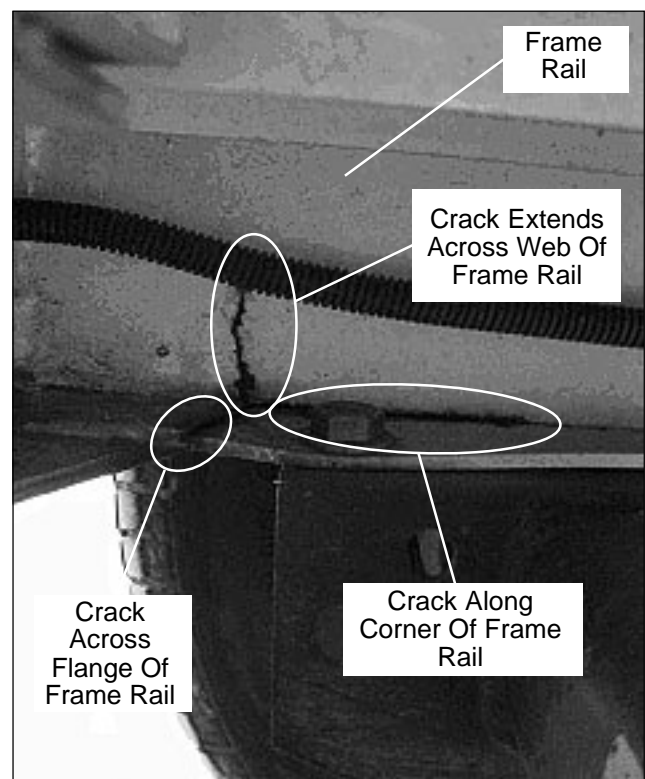

Figure 5 — Cracks Across The Web Of The Frame

5. Inspect each side of the frame near the fender mounting points for evidence of cracks (refer to Figure 4).
6. If there is a crack in the frame and it extends only across the flange of the frame rail and NOT across the web or along the corner of the frame rail (refer to Figure 5), the chipper can continue to be used, but a Frame Reinforcement Kit must be installed. The frame must be inspected at the beginning of each shift for growth of the crack. If the crack extends through the smaller (outer) flange of the mounting completely away from the axle tube, take the unit out of service immediately. To return the unit to service temporarily, the cracks may be welded closed by a qualified welder. Daily inspections of this area must continue until Altec has made the final repair.
7. Record the outcome of the inspection on the CSN 531 Inspection Sheet and fax it to AEP using the fax number on the sheet. The inspection information is very important so that AEP may be able to contact customers for the repair.

This repair is covered under the Warranty System.

CSN 531 Inspection Sheet

Complete this form and FAX to: 1-919-528-8012

Model	Serial Number	<u>Axle Mounting Bracket Cracks</u>		<u>Frame Cracks</u>		Date Inspected
		Yes	No	Yes	No	

Make additional copies of this form, as needed, for additional units. Contact Altec Forestry Support at 1-877-I FLY ALTEC (1-877-435-9258) for further repair information.

Company Name: _____ Phone _____

Company Contact: _____

Company Street Address: _____

State: _____ ZIP Code: _____

Signature: _____