



Date: April 6, 2011
Motor Vehicle Recall Notification - Recall Campaign No. 10V-434

Dear Valued Customer:

This notice is sent to you in accordance with the requirements of the National Traffic and Motor Vehicle Safety Act.

REASON FOR THIS RECALL

Newmar Corporation has determined that a defect which relates to motor vehicle safety exists in specific motor homes.

Based upon information provided by Dimplex North America, Newmar has determined that a potential fire hazard exists in the following motor homes manufactured between August 16, 2001 and June 2, 2010 and equipped with specific plug-in remote control receivers supplied by Dimplex North America, Ltd. for electric fireplace operation:

- 2006 - 2007 Essex DP
2006 - 2010 Torrey Pine FW
2004 - 2009 Kountry Aire FW
2006 Mountain Aire DP
2004 - 2005 Kounry Star FW
2002 - 2005 Mountain Aire FW
2006 - 2010 Cypress FW

Vehicles equipped with one of the following plug-in remote control kit models are covered by this recall:

- Model No. 47-1001
Model No. 47-1010-R
Model No. APT-1315
Doc. ID# 255K656-61-8367R (for older models that do not have a model number)

These plug-in remote control kits were installed with your fireplace.

In some instances, the plug-in remote control receiver can overheat, posing a fire hazard. You may continue to safely operate the electric fireplace or stove when connected directly to an electrical outlet without the plug-in remote control receiver.

These motorhomes require immediate service. Continued use poses a potential safety hazard.

WHAT WE WILL DO

Newmar Corp., in cooperation with Dimplex North America, will provide owners with a replacement remote control kit free of charge.

NOTE: This recall is being conducted simultaneously through NHTSA and the CPSC. If you have previously received notice of this recall and received your free replacement remote control kit, there is nothing further for you to do.

WHAT YOU NEED TO DO

To receive a free replacement remote control kit, please do the following:

- 1. Locate your remote control receiver behind the electric fireplace or stove on your vehicle (if applicable, refer to the attached guide, "Remote Control Replacement Instructions for BF6000, BF6000*, DF2603, NNF5500"); remove the receiver from the electrical outlet and unplug the fireplace or stove from the receiver.
2. Locate the Model # / Doc. ID # and Date Code of the receiver using the enclosed bulletin, "How to Identify Recalled Plug-In Remote Control Receivers," as a guide.
3. Confirm that your remote control receiver is covered by this recall by comparing the Model # to the product list above. If your product is covered, please note the Model # / Doc. ID # and the Date Code in the space provided below and continue to Step 4. The recalled receiver will be replaced with a new version, Model No. 1010-R* (note the asterisk *). On the new version, the name "Dimplex" appears on the front of the receiver in red. If yours is a Model No. 1010-R*, your remote has been replaced and you can continue to use it, but you should provide the vehicle information listed in Step 4 to Dimplex North America Technical Customer Service at the number provided in Step 6.

4. Note the make, model, model year and the vehicle identification number (VIN) of your vehicle in the space provided below.
5. Dispose of the receiver.
6. Contact Dimplex North America Technical Customer Service at 1-888-285-7773 from 8 am - 4:30 pm EST Monday through Friday. Please have your product and vehicle information readily available (as per Step 4).

If you need assistance locating the remote control receiver or locating the Model # / Doc. ID # or the Date Code on your receiver, you may contact Dimplex North America at the number listed in Step 6 for assistance.

If you previously paid to replace a recalled Dimplex remote control receiver that failed due to this defect, you may be eligible to be reimbursed for your costs. Please contact the NewmarService Department at 800-731-8300 to determine your eligibility.

Federal regulations require that any vehicle lessor receiving this recall notification must forward a copy of this notice to the lessee within ten days.

If Dimplex North America or Newmar Corporation fail or are unable to provide a replacement remote control kit within a reasonable time, you may submit a complaint to the Administrator, National Highway Traffic Safety Administration, 1200 New Jersey Ave., SE., Washington DC 20590; or call the toll-free Vehicle Safety Hotline at 1-888-327-4236 (TTY: 1-800-424-9153); or go to <http://www.safercar.gov>.

If you no longer own the vehicle covered by this Safety Recall Notice, please provide the name and contact information for the new owner by calling the Newmar Service Department at 800-731-8300. This will enable us to advise the new owner of this recall.

Your safety and satisfaction with your Newmar product is important to us and we regret any inconvenience to you.

Sincerely,

Newmar Corporation

Enclosures: Remote Control Replacement Instructions for BF6000, BF6000*, DF2603, NNF5500
How to Identify Recalled Plug-In Remote Control Receivers

INFORMATION TO BE PROVIDED TO DIMPLEX NORTH AMERICA, LTD.

Remote Control Receiver:

Model # / DOC. ID # _____

Date Code _____

Vehicle:

Make _____

Model _____

Year _____

Vehicle Identification Number (VIN) (17 digits) _____

How to identify recalled plug-in remote control receivers:

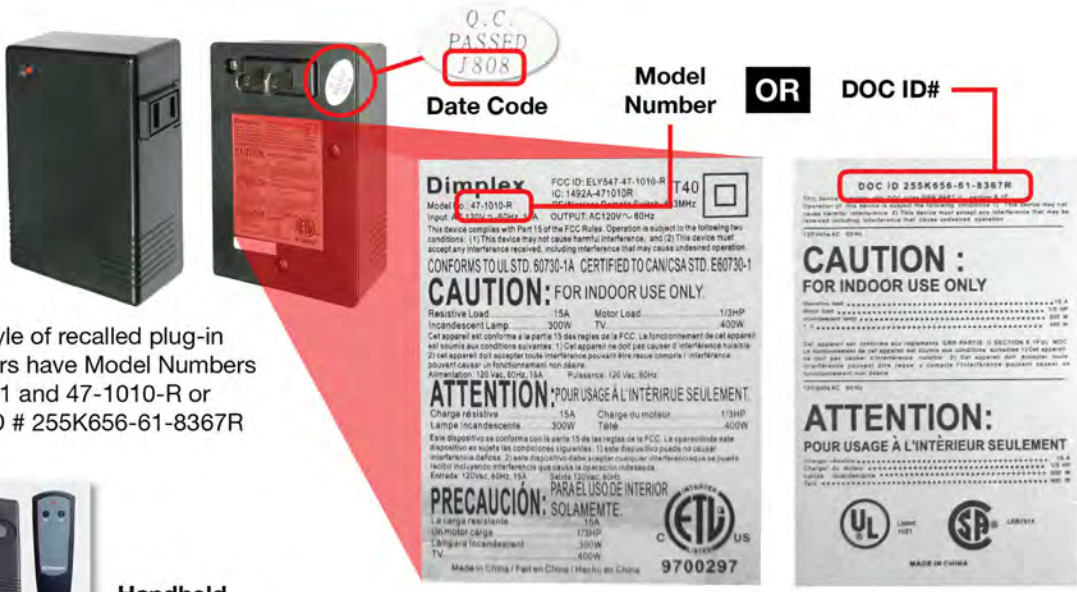

This style of recalled plug-in receivers have Model Numbers 47-1001 and 47-1010-R or DOC ID # 255K656-61-8367R



Handheld Transmitters

This style of recalled plug-in receiver has Model Number APT-1315



Remote Control Replacement Instructions For BF6000, BF6000*, DF2603, NNF5500

- 1) Remove the fireplace from its installed location to access the plug-in remote control behind the unit.
- 2) If the fireplace is fixed in place, follow the following instructions for fireplace removal:

- a) Remove retaining clip using a slot screwdriver

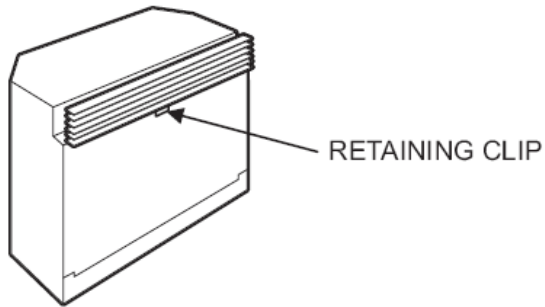

- b) Remove glass

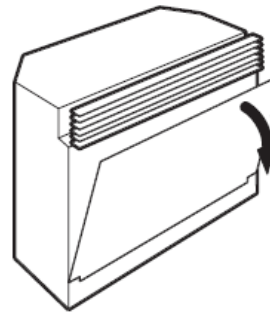

- c) Remove log set

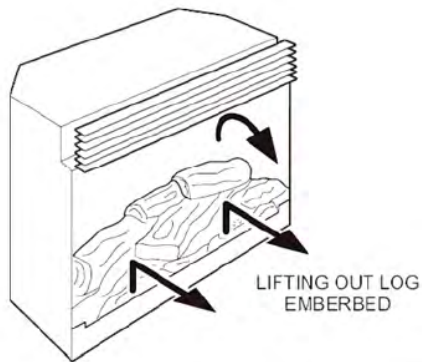

- d) Remove the screws that fasten the bottom of the fireplace to the floor.

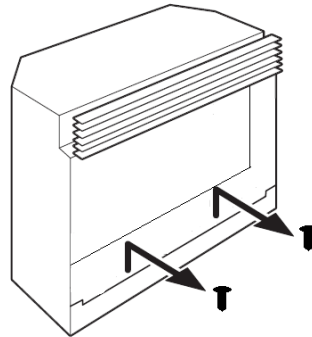

- e) Pull the fireplace from its installed location to access the plug-in remote control.

If you need assistance locating the remote control receiver or removing the fireplace to access the remote, please contact Dimplex North America Technical Customer Service at 1-888-DIMPLEX (1-888-346-7539) from 8 am – 4:30 pm Eastern Monday through Friday; when prompted, press “1” for “Customer Service” and then “1” again for “Parts Service and Technical Support”.