



903 South Main Street • P.O. Box 460 • Middlebury, IN 46540 • (574) 825-0608 • Fax (574) 825-0572

VEHICLE SAFETY DEFECT SERVICE BULLETIN

IMPORTANT

- Model Year 2004 Legacy Fifth-Wheels & 2005 Designer Fifth-Wheels are involved in a safety recall.
- Schedule an appointment with your Jayco dealer.
- This service will be performed for you at no charge.

Dear Jayco Owner:

This notice is sent to you in accordance with the requirements of the National Traffic and Motor Vehicle Safety Act.

Jayco, Inc. has decided that a defect, which relates to motor vehicle safety, exists in specific Model Year 2004 Legacy Fifth-Wheels & 2005 Designer Fifth-Wheels manufactured between January 8, 2004 and February 23, 2005. These vehicles were manufactured with certain plug-in remote control receivers supplied by Dimplex North America, Ltd. These remote control receivers are used to operate the electric fireplace or electric stove [or, possibly, another appliance] on your vehicle.

This decision was based upon information provided by Dimplex North America that a defect exists in some of the remote control receivers that Dimplex manufactured from 1998 through 2008. Jayco installed these kits as original equipment in certain vehicles it manufactured from January 8, 2004 and February 23, 2005. Our records indicate that you are the owner of one of the affected vehicles.

Only vehicles that were equipped with one of the following plug-in remote control kits models are covered by this recall:

Model No. 47-1001

Model No. 47-1010-R

Model No. APT-1315

Doc. ID # 255K656-61-8367R (for older models that do not have a model number)

These plug-in remote control kits were sold individually and were also packaged with the following electric fireplace and stove kits:

Electric Fireplace Kits	Electric Stove Kit
BF6000	DS5598RC
BF6000*	
DF2305	
DF2603	
DFI2309	
NNF5500	

In some instances, the plug-in remote control receiver can overheat, posing a fire hazard. You may continue to safely operate the electric fireplace or stove when connected directly to an electrical outlet without the plug-in remote control receiver.

The remedy for the affected Fifth-Wheels will involve inspection and replacement of the remote control kit. If you choose, you may perform this repair yourself or you may have it performed by a Jayco dealer near you. This repair will be done at no charge to you. If you have had this repair performed before you received this letter, you may be eligible to receive reimbursement for the cost of obtaining a pre-notification remedy of the problem associated with this recall. For more information or if you are unable to have this repair performed, please contact Jayco Customer Service at 800-283-8267 for assistance.

NOTE: This recall is being conducted simultaneously through NHTSA and the CPSC. If you have previously received notice of this recall and received your free replacement remote control kit, there is nothing further for you to do.

To receive a free replacement remote control kit, please do the following:

1. Locate your remote control receiver behind the electric fireplace or stove on your vehicle (if applicable, refer to the attached guide, “Remote Control Replacement Instructions for BF6000, BF6000*, DF2603, NNF5500”); remove the receiver from the electrical outlet and unplug the fireplace or stove from the receiver.
2. Locate the Model # / Doc. ID # and Date Code of the receiver using the enclosed bulletin, “*How to Identify Recalled Plug-In Remote Control Receivers,*” as a guide.
3. Confirm that your remote control receiver is covered by this recall by comparing the Model # to the product list above. If your product is covered, please note the Model # / Doc. ID # and the Date Code in the space provided below and continue to Step 4. The recalled receiver will be replaced with a new version, Model No. 1010-R* (note the asterisk *). On the new version, the name “Dimplex” appears on the front of the receiver in red. If yours is a Model No. 1010-R*, your remote has been replaced and you can continue to use it, but you should provide the vehicle information listed in

- Step 4 to Dimplex North America Technical Customer Service at the number provided in Step 6.
4. Note the make, model, model year and the vehicle identification number (VIN) of your vehicle in the space provided below.
 5. Dispose of the receiver.
 6. Contact Dimplex North America Technical Customer Service at 1-888-285-7773 from 8 am – 4:30 pm EST Monday through Friday. Please have your product and vehicle information readily available (as per Step 4).

If you need assistance locating the remote control receiver or locating the Model # / Doc. ID # or the Date Code on your receiver, you may contact Dimplex North America at the number listed in Step 6 for assistance.

If Dimplex North America fails or is unable to provide a replacement remote control kit within a reasonable time, you may wish to contact Administrator, National Highway Traffic Safety Administration, 1200 New Jersey Avenue SE, Washington, DC 20590; or call the toll-free Vehicle Safety Hotline at 1-888-327-4236 (TTY: 1-800-424-9153); or go to <http://www.safercar.gov>.

If you choose to have this repair performed by a Jayco dealer and the dealer is unable to perform the recall within a reasonable time frame, please contact Jayco Customer Service for further instructions. Any non-Jayco dealer must contact Jayco prior to making the recall repairs for proper authorization and instruction. If you have sold or traded your vehicle, or for any reason cannot have this recall service performed, please let us know by contacting Jayco Customer Service at 800-283-8267.

Federal regulations require that any vehicle lessor receiving this notice must forward a copy of this notice to the lessee within **ten days**.

If, however, you take your recreational vehicle to your dealer on the agreed service date and the dealer does not remedy this condition on that date or within three (3) days, please contact our Customer Service department at 800-283-8267. After contacting your Jayco dealer and Jayco Customer Service and you are not able to have the safety defect remedied without charge and/or within a reasonable time, you may wish to submit a complaint to the Administrator, National Highway Traffic Safety Administration, 1200 New Jersey Avenue SE, Washington, DC 20590; or call the toll-free Vehicle Safety Hotline at 1-888-327-4236 (TTY: 1-800-424-9153); or go to <http://www.safercar.gov>.

We apologize for this inconvenience. However, we have taken this action in the interest of your safety and continued satisfaction with your Jayco recreational vehicle.

Sincerely,

Jayco, Inc.

Remote Control Replacement Instructions For BF6000, BF6000*, DF2603, NNF5500

- 1) Remove the fireplace from its installed location to access the plug-in remote control behind the unit.
- 2) If the fireplace is fixed in place, follow the following instructions for fireplace removal:

- a) Remove retaining clip using a slot screwdriver

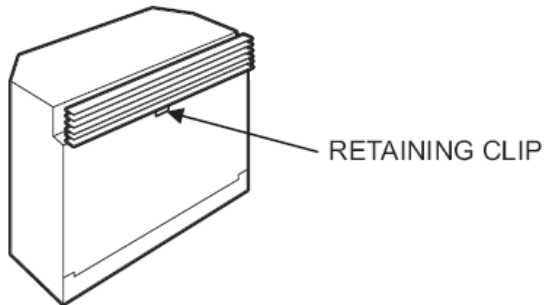

- b) Remove glass

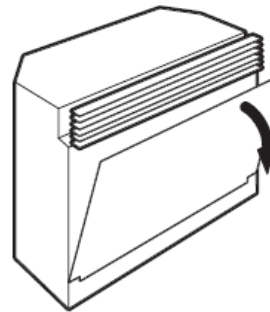

- c) Remove log set

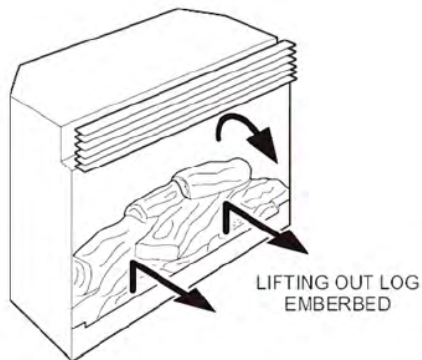

- d) Remove the screws that fasten the bottom of the fireplace to the floor.

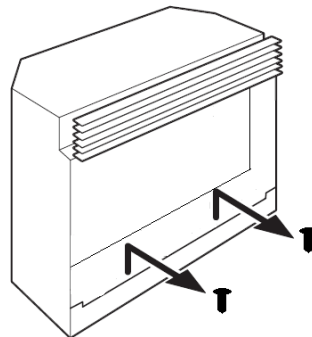

- e) Pull the fireplace from its installed location to access the plug-in remote control.

If you need assistance locating the remote control receiver or removing the fireplace to access the remote, please contact Dimplex North America Technical Customer Service at 1-888-DIMPLEX (1-888-346-7539) from 8 am – 4:30 pm Eastern Monday through Friday; when prompted, press “1” for “Customer Service” and then “1” again for “Parts Service and Technical Support”.

How to identify recalled plug-in remote control receivers:

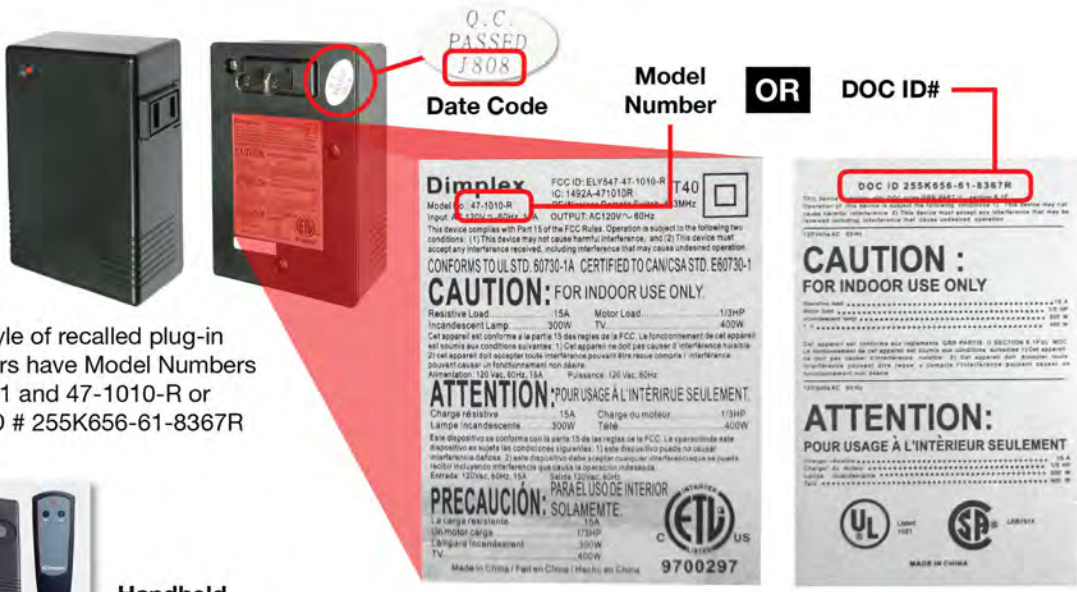

This style of recalled plug-in receivers have Model Numbers 47-1001 and 47-1010-R or DOC ID # 255K656-61-8367R



Handheld Transmitters

This style of recalled plug-in receiver has Model Number APT-1315



INFORMATION TO BE PROVIDED TO DIMPLEX NORTH AMERICA, LTD.

Remote Control Receiver:

Model # / DOC. ID # _____

Date Code _____

Vehicle:

Make _____

Model _____

Year _____

Vehicle Identification Number (VIN) (17 digits) _____