

SAFETY RECALL BULLETIN

Subject: **Safety Recall 10C4**
EPA07 DD13 and DD15 High Pressure Fuel Pump

Defect Involved

Detroit Diesel Corporation (DDC) has determined that some certified EPA07 DD13 and DD15 engines may have high pressure fuel pump elements that were made incorrectly and could potentially crack. These high pressure fuel pump elements will be replaced. This will prevent fuel leaks and customer dissatisfaction.

Engines Involved

A list of engines located in your area of responsibility that require this correction is attached. **NOTE: AN ADDITIONAL LIST OF UNITS HAS BEEN ADDED.**

The table below gives descriptive information to help identify the affected units:

Model Series	Model Family	Model Year	Inclusive Mfg. Date (From) (To)	Descriptive Information
D472900 D472901 D472902	DD15	2009	August, 2009, through May, 2010	All Applications
D471901 D471910	DD13	2009	August, 2009, through May, 2010	All Applications

[Inclusive Mfg. Dates of Units PREVIOUSLY released on April 4, 2011](#)

D472900 D472901 D472902	DD15	2009	January, 2009, through July, 2009	All Applications
D471901 D471910	DD13	2009	January, 2009, through July, 2009	All Applications

Owner Notification

Detroit Diesel will notify owners of equipment incorporating engines identified with this safety recall. A copy of the owner letter that will be used by Detroit Diesel is enclosed with this recall notice.

Distributor / Dealer Modification Responsibility

Detroit Diesel Repair Facilities are to service all engines subject to this recall. The recall is to be performed at no charge to owners on all affected engines under the provisions of this recall notice.

Please use the appropriate steps, noted below, for indicating that **Safety Recall 10C4** has been completed.

Freightliner and Western Star Trucks

- Check the base label (**Form WAR259**) to see if **Safety Recall 10C4** has been completed. The base label is usually located on the passenger-side door about 12 inches (30 cm) below the door latch. If **Safety Recall 10C4** has been completed, no further work is needed. If base label is not located on the passenger-side door, please affix label (**Form WAR259**) 12 inches or 30 cm from the door latch.
- Upon completion of **Safety Recall 10C4**, clean a spot on the base label (**Form WAR259**), write the Safety Recall Number (**10C4**) on a blank, red completion sticker (**Form WAR260**), and attach it to the base label.

Ordering Information

If you do not have the appropriate Form or Labels (DDC_WAR 259, DDC_WAR 260, DDC_WAR 261) there are several ways which they can be obtained:

1. Through the Detroit Diesel Extranet and clicking on Access EPI or going directly to ddc@epiinc.com.
2. Fax your order to **(269) 968-4260**; or
3. Contact EPI directly at **(269) 964-4600** Ext. **5806**.

Parts Information

The new high pressure fuel pump elements and other necessary parts to replace them are included in service kit P/N: A4720700001.

Corrective Procedure

You will need the following tools:

- Large C-clamp, size 3"x10" or 3"x12" with non-marring pad (i.e., plastic or rubber) for contact with pumping element



- Clean fuel or oil (for o-ring lubrication)
- Torque wrench (recently calibrated to ensure accuracy)
- High pressure fuel pump holding fixture P/N: W470589014000
- Lint free shop towels
- T-50 Torx bit
- ESOC-350 Fuel System Primer

NOTICE:

A video has been prepared for this repair procedure. Please go to DDCSN.com to view the video prior to beginning the work.

1. Apply the parking brake, chock the wheels, disconnect the batteries, and perform any other applicable safety steps.
2. Thoroughly clean and dry the high pressure fuel pump and the fuel lines in the high pressure pump area.

3. Check the date code on the high pressure fuel pump identification tag. It is possible the pump has already been replaced for other reasons and therefore does not need to have the pumping elements replaced. The date code is in the format of YY-MM-DD, and is located in the upper left side of the tag. The pump shown in Figure 1a was thus made on September 9, 2008. Pumps that need to be repaired were built between January 20, 2009, (date code 09-01-20) through November 4, 2009, (date code 09-11-04).
 - a) If the date code equals or is between these two dates, proceed to step 4.
 - b) If the date code is NOT between these two dates, no further work is necessary and proceed to step 27.
 - c) If the date code label looks like Figure 1b, no further work is necessary and proceed to step 27.



Figure 1a – High Pressure Fuel Pump Identification Tag



Figure 1b – Alternate High Pressure Fuel Pump Identification Tag

4. Remove the high pressure pump from the engine. Reference section 14.2 in the EPA07/10 Fuel Manual (DDC-SVC-MAN-0082).
5. Mount the high pressure fuel pump holding fixture P/N: W470589014000 in a bench vise. Remove the gear locking tooth and four bolts from the tool. Install the bolts backwards into the pump holding fixture. See Figure 2.



Figure 2 – High Pressure Fuel Pump Holding Fixture

6. Remove and discard the high pressure pump mounting o-ring. Mount the fuel pump to the pump holding fixture and secure it using the four supplied nuts. See Figure 3.



Figure 3 – High Pressure Fuel Pump In Holding Fixture

7. Ensure that the "T" on the timing plate is pointed at the 12 o'clock position. If it is not, use a non-marring strap wrench or tool J-48669 to rotate the pump gear until the "T" is aimed at the 12 o'clock position. See Figure 4.

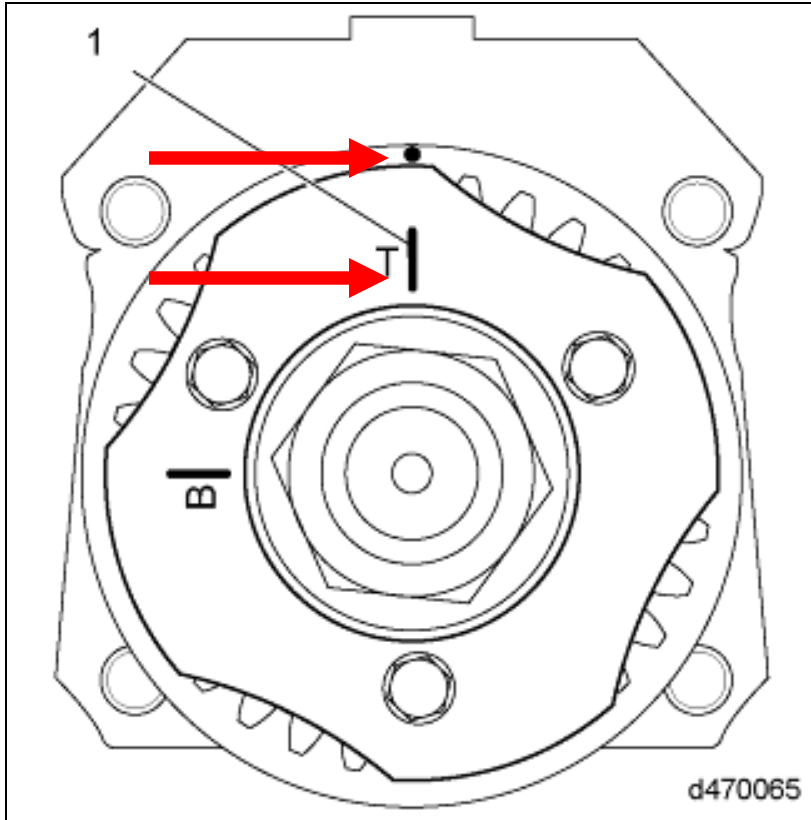

Figure 4 – High Pressure Fuel Pump Timing Plate

8. Use a large C-clamp with a non-marring clamping surface (i.e., plastic or rubber) and apply light pressure onto the top of the front element furthest from the gear to hold the spring pressure from pushing the element out of the pump housing when the bolts are removed. See Figure 5.



Figure 5 – High Pressure Fuel Pump With C-Clamp On Front Element

9. Remove the two T-50 Torx bolts from the front pumping element. See Figure 6.



Figure 6 – High Pressure Fuel Pump T-50 Torx Bolt Removal

10. Remove the front element and spring from the pump housing. See Figure 7.

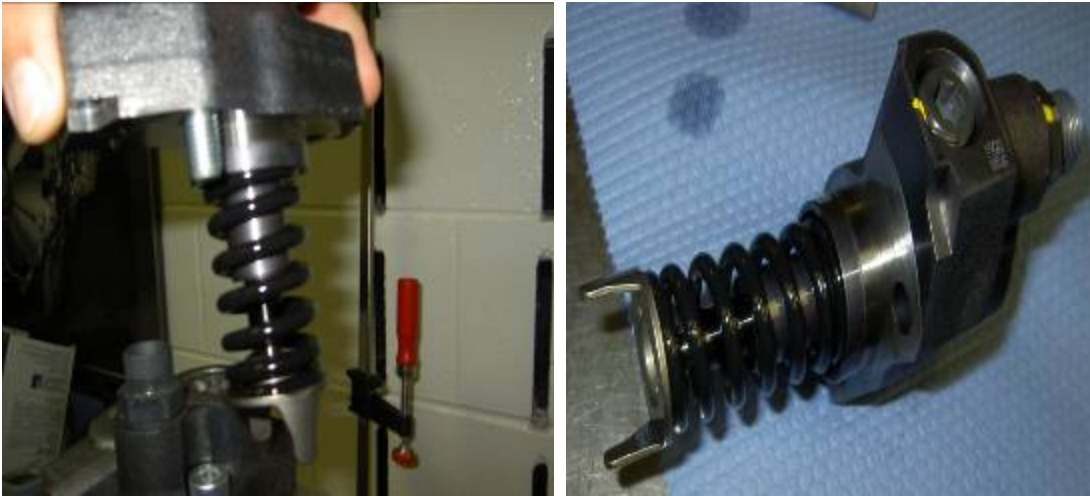

Figure 7 – Front Element Removal

11. Inspect the spring on the pumping element. If the spring is broken, replace the entire fuel pump, and go to step 25.

NOTICE:

Do **NOT** remove the metal puck from the fuel pump.

12. Ensure that the metal puck is still in place and is centered in the roller cup. If the metal puck is not centered, use a clean pick to center the puck. See Figure 8.

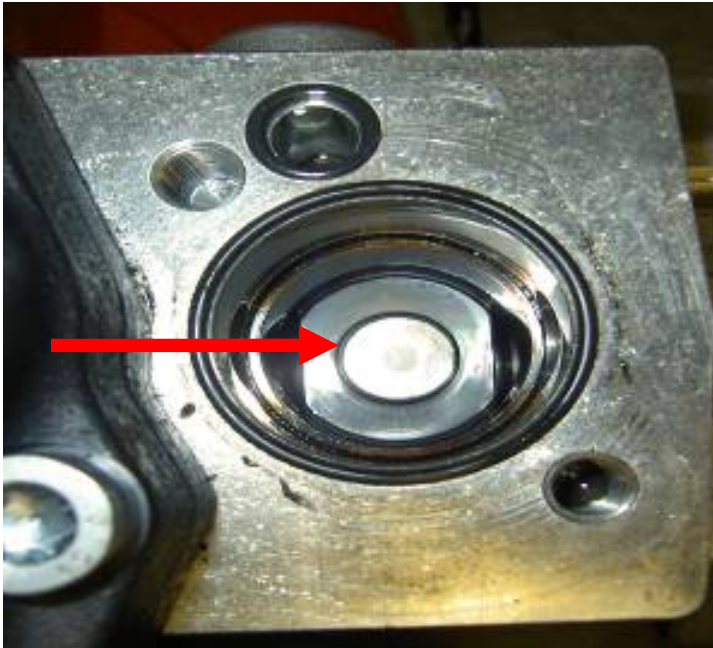

Figure 8 – High Pressure Fuel Pump Metal Puck Placement

13. Remove the two o-rings from the top of the pump.

NOTICE:

Do **NOT** use compressed air around the pumping element sealing surface.

14. Clean the area around the pumping element sealing surface with a clean lint free cloth. Ensure the bolt holes are clean and fluid free. Do not use compressed air! See Figure 9.

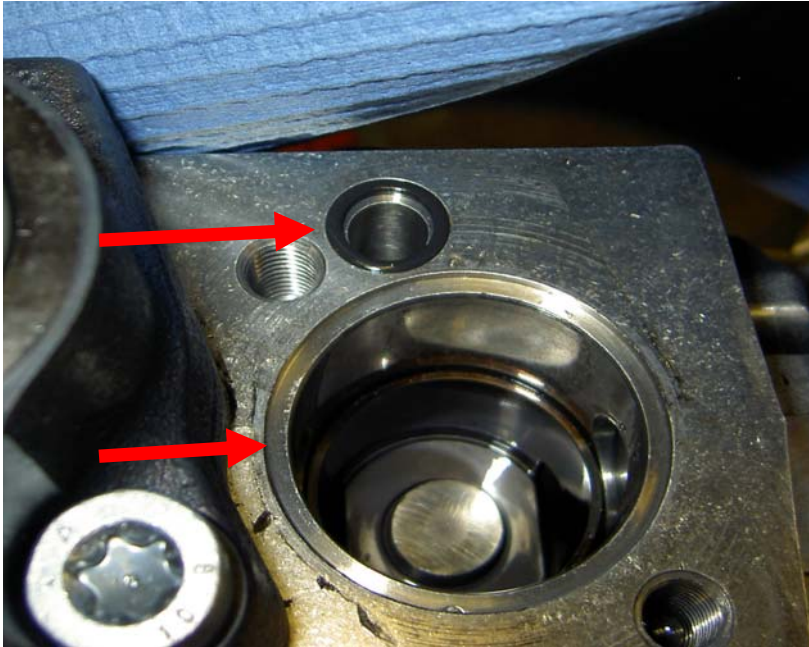

Figure 9 – Cleaning Of High Pressure Fuel Pump Element Sealing Surface

15. Lubricate the two new o-rings included in the service kit with clean fuel or oil and install them into the receiver grooves in the pump housing.

16. Align the two tangs on the spring retainer with the holes in the roller cup.
See Figure 10.

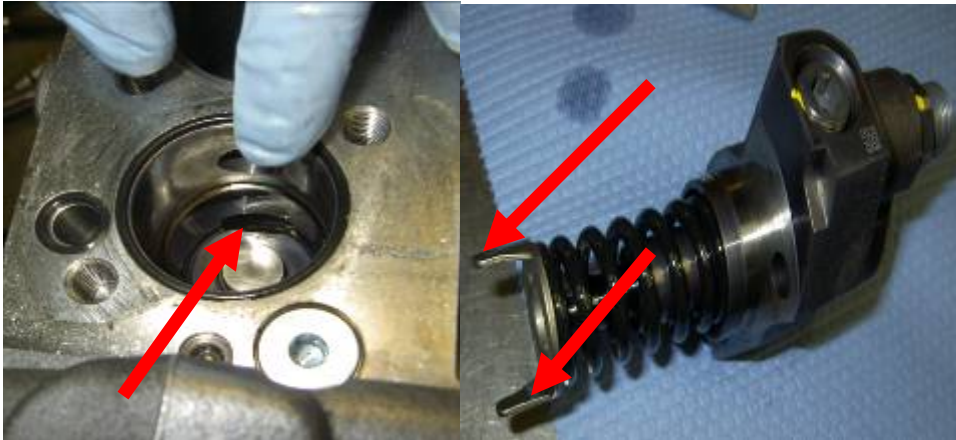

Figure 10 – Spring Retainer Tang Alignment

NOTICE:

Do **NOT** disassemble the new fuel pump spring and pumping element.

17. Install the new spring and pumping element into the bore and seat the spring retainer and piston against the roller cup and puck. See Figure 11.



Figure 11 – New Spring And Pumping Element Installation

18. Install the two T-50 Torx bolts through the pumping element housing into the pump crank case and start the threads by hand so they can be used as a guide.
19. Install the C-clamp with a non-marring clamping surface (i.e., plastic or rubber) and pull the pumping element straight down onto the pump housing with the clamp. See Figure 12.

NOTICE:

The pumping element must be installed straight down into the housing to avoid damage to the sealing surfaces. The two T-50 Torx bolts must be used to guide the element straight into the housing, but **DO NOT** use the bolts to pull the element onto the pump.



Figure 12 – High Pressure Fuel Pump Element Installation

20. Torque the two T-50 Torx bolts to 42 Nm (31 lb-ft). See Figure 13.



Figure 13 – High Pressure Fuel Pump Element Installation

21. Rotate the fuel pump gear 90 degrees clockwise until the “B” is aimed at the 12 o’clock position and repeat steps 8 through 20 on the rear pumping element closest to the gear. See Figure 14.

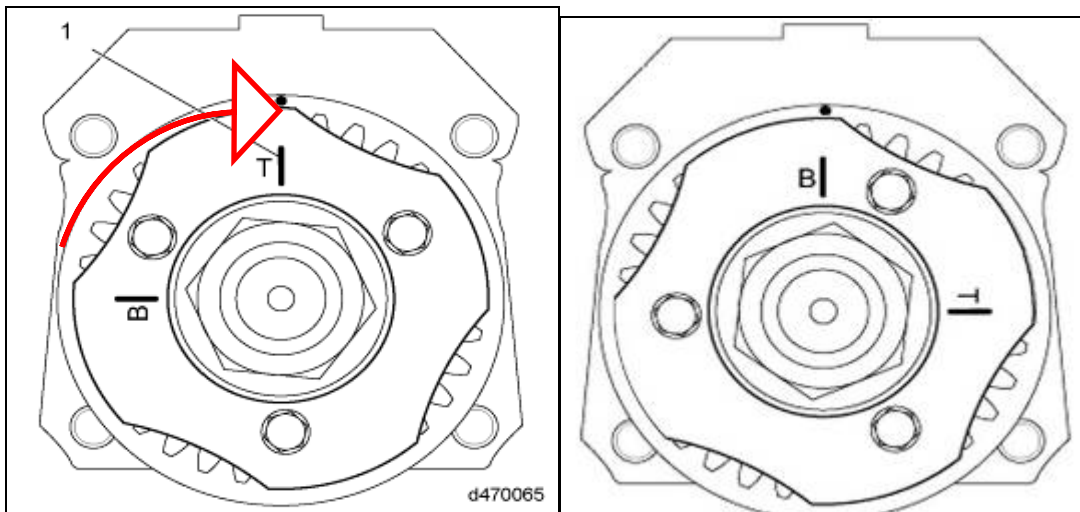

Figure 14 – High Pressure Fuel Pump Timing Plate

22. When the second pumping element has been completed, rotate the gear clockwise to align the “T” on the timing plate to the dot on the housing. See Figure 4.
23. Install the new high pressure pump mounting o-ring included in the service kit. Lubricate the new o-ring lightly with clean engine oil.
24. Install the pump onto the engine. Reference section 14.3 of the EPA07/10 Fuel Manual (DDC-SVC-MAN-0082).
25. Install the fuel lines. Reference section 19.3 of the EPA07/10 Fuel Manual (DDC-SVC-MAN-0082). Ensure all of the fuel lines, dampers, P-clips, and mounting brackets are installed correctly. See Figure 15.

NOTICE:

The picture below shows the fuel lines for engine serial number 47x90xS0012796 and higher. Engines lower than that serial number have a different mounting bracket. Reference section 19.3 of the EPA07/10 Fuel Manual (DDC-SVC-MAN-0082).

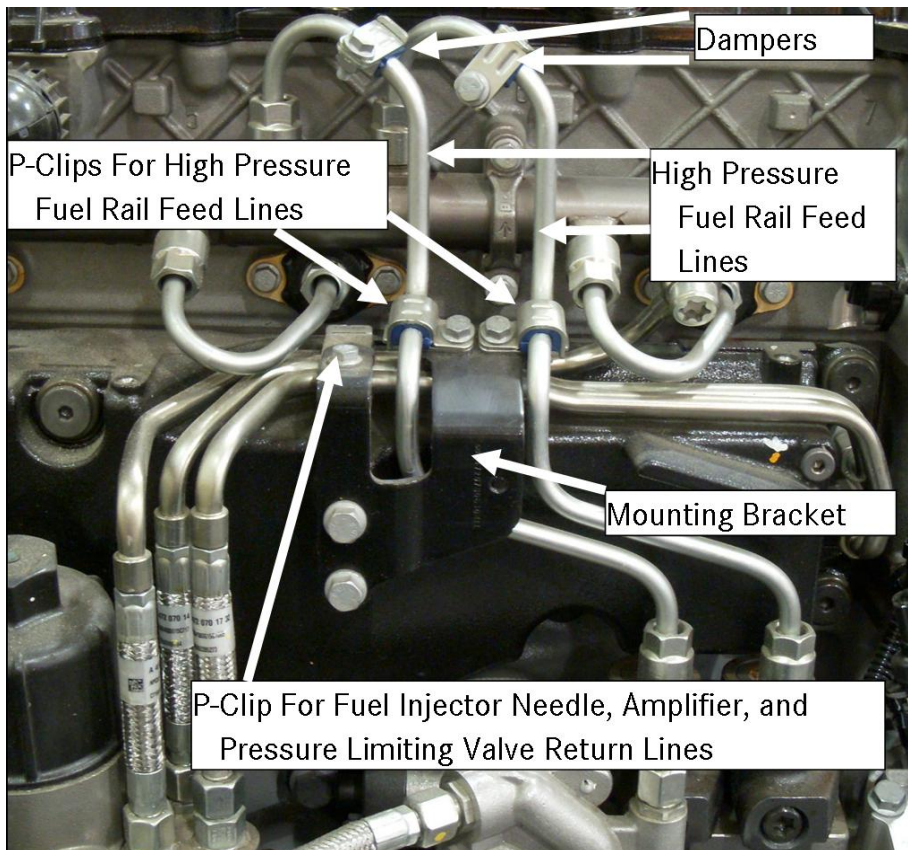

Figure 15 – High Pressure Fuel Lines And Mounting Bracket Installation For Engine Serial Number 47x90xS0012796 And Higher

26. Prime the fuel system. Reference section 2.1 “Priming the fuel system using ESOC 350 fuel priming pump” in the EPA07/10 Fuel Manual (DDC-SVC-MAN-0082).

27. Verify repairs.

- a) If the engine is installed in a chassis, run the engine to operating temperature and check for leaks or drivability issues.
- b) If the engine is not in a chassis and cannot be driven, use the low pressure leakage test kit J-48710 (with adaptor kit W470589039100 if necessary) and pressurize the fuel system to 75 PSI and check for leaks. Reference section 4.1 of the EPA07/10 DDEC VI/10 Electronics And Troubleshooting Manual (DDC-SVC-MAN-0084) for the leak test procedure.

Warranty Information

Claim Type:	04
Modification:	10C4
Fault Type:	ZZ
Primary Failed Part:	A4720900350
<u>Labor DD15:</u> With pump removal/replacement including element replacement:	5.6 hours
Pump serial number tag inspection. No repair necessary.	0.3 hour
<u>Labor DD13:</u> With pump removal/replacement including element replacement:	6.4 hours
Pump serial number tag inspection. No repair necessary.	0.3 hour
Labor Code: With pump removal/replacement including element replacement:	R10C4
Pump inspection no repair necessary:	R10C4A
Parts Return:	NONE

Should you have any additional questions, please contact Detroit Diesel.