

Wayne Hutchinson / TMS Toyota Customer Services
Quality Compliance
February 09, 2010
Approved By: Bob Waltz

To: All Toyota Dealers
From: Toyota Customer Services

Safety Recall – A0C
Certain Early Production 2010 Model Year Camry Vehicles Equipped with 4 Cylinder (2AR-FE) Engines
Brake Tube Inspection and/or Repositioning
*******URGENT*******

On February 9, 2010, Toyota filed a Defect Information Report (DIR) with the National Highway Traffic Safety Administration (NHTSA) informing the agency of our intent to conduct a voluntary Safety Recall on certain early production 2010 model year Camry vehicles equipped with the 4 cylinder (2AR-FE) engines.

Condition

- On certain early production 2010 model year Camry vehicles equipped with the 4 cylinder (2AR-FE) engine, a power steering pressure hose in the engine compartment may be the incorrect length. If this condition exists, a crimp on the power steering pressure hose may come in contact with the brake tube.
- Should this condition continue, a hole may wear in the brake tube and deplete the brake fluid in the vehicle. As a result, the brake pedal stroke will increase and lead to greater vehicle stopping distance.

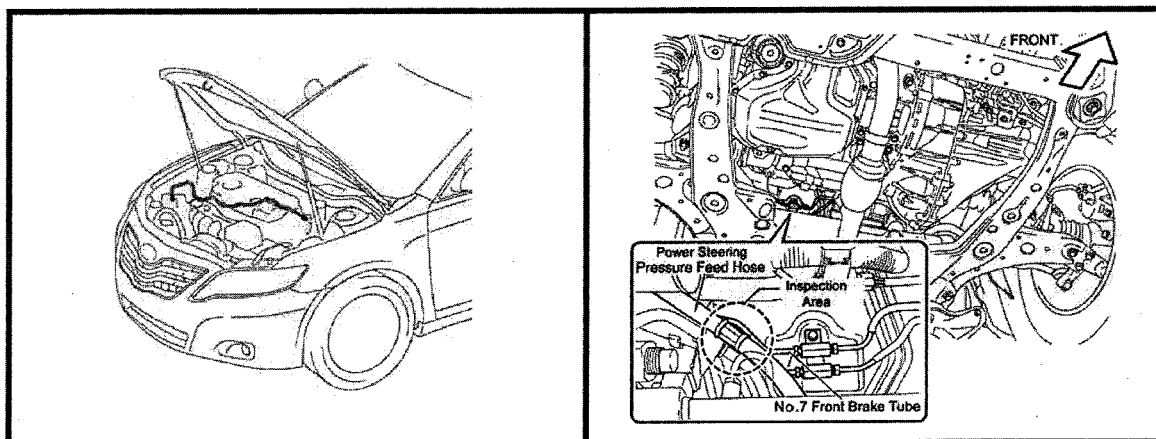

Safety Recall Remedy

- We request Toyota dealers to inspect and if necessary adjust the space between the brake tube and the power steering pressure hose crimp on the affected vehicles.
- Based upon the inspection results, the brake tube may need to be replaced in a limited number of cases.
- The inspection/adjustment and, if necessary, the brake tube replacement, will be performed at **NO CHARGE** to the vehicle owner.
- Owners will begin receiving notification via first class mail starting in mid-February 2010.

Involved Vehicles:

- There are approximately 7,300 Camry (2010 model year) vehicles involved in the U.S.

Customer and Media Contacts

- A Q&A has been attached for your use in the event you receive a customer contact. If a customer has further questions, please direct the inquiry to the Toyota Customer Experience Center at 1-800-331-4331.
- If you are a dealership associate and have any questions, please contact your District Service/Parts Manager.
- ***In the event you are contacted by the News media***, it is imperative that all media contacts (local and national) receive a consistent message. Please direct all media contacts to Brian Lyons (310) 468-2552 or John Hanson (310) 468-4718, in Toyota Corporate Communications. (Please do not provide these numbers to customers or call if you are a dealer associate.)

Thank you for your cooperation.



Safety Recall A0C

Certain Early Production 2010 Model Year Camry Vehicles Equipped with the 4 Cylinder Engines Brake Tube Inspection and/or Replacement

Q1: What is the condition?

A1: On certain early production 2010 model year Camry vehicles equipped with the 4 cylinder engine, a power steering pressure hose in the engine compartment may be the incorrect length. If this condition exists a crimp on the power steering pressure hose may come in contact with the No. 7 Front Brake Tube ("brake tube").

Should this condition continue, a hole may wear in the brake tube and deplete the brake fluid in the vehicle. As a result, the brake pedal stroke will increase and lead to greater vehicle stopping distance.

Q2: Are there any warnings that this condition exists?

A2: No, there are no specific warnings that this condition exists.

Q3: What is Toyota going to do?

Q3: Any Toyota dealer will inspect and if necessary adjust the space between the brake tube and the power steering pressure hose crimp. Based upon the inspection results, the dealership may need to replace the brake tube. The inspection/adjustment and, if necessary, the brake tube replacement, will be performed at **NO CHARGE** to the vehicle owner.

Q4: When will owners be notified?

Q4: Toyota will notify owners by first class mail starting in mid-February, 2010.

Q5: Which and how many vehicles are involved?

A5: There are approximately 7,300 Camry vehicles involved in the U.S.

Q6: What is the production period of the affected vehicles?

A6: The affected Camry vehicles were produced from early February, 2009 to late March, 2009.

Q7: Are there any other Toyota or Lexus vehicles involved?

A7: No, this specific condition only affects certain early production 2010 model year Camry vehicles equipped with the 4 cylinder engine.

Q8: How long will the inspection take?

A8: The inspection will take approximately 45 minutes. However, depending upon the dealer's work schedule and the inspection results, it may be necessary to make the vehicle available for a longer period of time.

Q8a: What if replacement of the Brake Tube becomes necessary. How long will the repair take?

A8b: As these parts are not normally stocked by dealerships, it will take a few days for the dealer to order and receive them. The Toyota dealer will make every effort to assure each customer's utmost convenience during this waiting period.

Q9: What should an owner do if they experience the condition or have immediate concerns about the current safety of their vehicle?

A9: If an owner has immediate concerns they are requested to contact their local Toyota dealer for inspection and if applicable repair.

Owners may also contact the Toyota Customer Experience Center (1-800-331-4331) for additional assistance.

TOYOTA

Update: 02/16/2010 – Update to Flow Chart in Warranty Processor Instructions.

Toyota Motor Sales, U.S.A., Inc.
19001 South Western Avenue
Torrance, CA 90501
(310) 468-4000

To: All Toyota Dealer Principals, Service Managers, Parts Managers

Subject: Safety Recall – A0C
Certain Early Production 2010 Model Year Camry Vehicles
Equipped with 4 Cylinder (2AR-FE) Engines
Brake Tube Inspection and/or Repositioning

On February 9, 2010, Toyota filed a Defect Information Report (DIR) with the National Highway Traffic Safety Administration (NHTSA) informing the agency of our intent to conduct a voluntary Safety Recall on certain early production 2010 Model Year Toyota Camry vehicles equipped with the 4 cylinder (2AR-FE) engines.

Condition

On **7,314** early production 2010 model year Camry vehicles equipped with the 4 cylinder (2AR-FE) engine, a power steering pressure hose in the engine compartment may be the incorrect length. If this condition exists, a crimp on the power steering pressure hose may come in contact with the No. 7 Front Brake Tube ("brake tube"). Should this condition continue, a hole may wear in the brake tube and deplete the brake fluid in the vehicle. As a result, the brake pedal stroke will increase and lead to greater vehicle stopping distance.

Safety Recall Remedy

We request Toyota dealers to inspect and if necessary adjust the space between the brake tube and the power steering pressure hose crimp on the affected vehicles. Based upon the inspection results, the brake tube may need to be replaced. The inspection/adjustment and, if necessary, the brake tube replacement, will be performed at **NO CHARGE** to the vehicle owner.

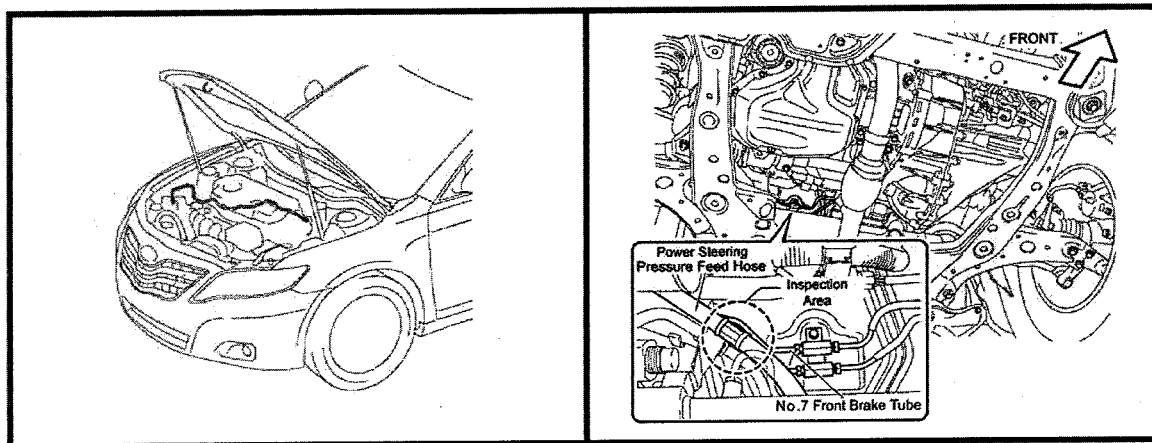

1. Owner Notification Letter Mailing Date

The owner notification will commence in mid-February, 2010.

Please note that only owners of the specific 7,314 vehicles will be notified. If your dealership is contacted by an owner of an involved vehicle, who has not yet received a notification, please **verify eligibility by confirming through Dealer Daily/TIS prior to performing repairs**. Dealers should perform the repair as outlined in the attached Technical Instructions.

2. Vehicles in Dealer Stock

As required by Federal law, dealers are not to deliver any new vehicles in their inventory, which are involved in this Safety Recall. Dealers must perform the Safety Recall on all new vehicles in stock prior to sale or lease. Vehicle Safety Recall completion can be verified through TIS.

3. Dealer/Owner Lists

Summary Reports containing the **number** of involved vehicles in your dealership's primary marketing area and a VIN list containing vehicles in dealer stock have been distributed to each dealership's Service and Parts Manager. (VIN lists of vehicles in the dealership's PMA will no longer be provided. Please verify eligibility by confirming through Dealer Daily or TIS prior to performing repairs.)

4. Number and Identification of Involved Vehicles

There are 7,314 specific Camry (2010 model year) vehicles involved.

Model	WMI	MY	VIN Range	
			VDS	Range
Camry	4T1	2010	BF3EK	U001018 – U001021
				U500012 – U503263
	4T4			R001024 - R012346

5. Parts Ordering

It is anticipated that this inspection and if necessary repositioning will not require any parts. In the unlikely event that the No. 7 Front Brake Tube requires replacement, the following part will need to be ordered. It will be placed on Manual Allocation Control (MAC) until further notice. While the parts are on MAC, a representative from TMS will review each order and contact the dealership's Parts Manager as required, to verify the necessity of the order. This will assure an adequate and balanced parts inventory.

If there are questions regarding operational or logistical issues, dealership associates should go through their normal channels for resolution (e.g. PDC, Dealer Parts Call Center for TMS Region Dealers, DSPMs).

If there are special circumstances where a dealership requires parts release, dealership associates should contact (310) 468-5516. The associate should have the following information ready to expedite research of the order status:

1. Dealer Information (Dealer Code, Contact Name, Telephone Number)
2. Order Reference Number
3. Customer Name and Vehicle 17-digit VIN

Part No.	Part Name	Qty/Unit
47317-06160*	No. 7 Front Brake Tube	1*

 ***Part replacement is based on inspection results. DO NOT order parts until the vehicle inspection has been completed. Refer to the Technical Instructions posted on TIS for additional information.**

IMPORTANT PARTS ORDERING REMINDER

Effective March 1, 2009, Safety Recall Service Campaign (SSC/LSC) and Customer Support Program (CSP) parts do not earn Parts Return Credit Accrual and are not returnable under the Monthly Return Program. It is recommended that you order these parts based on appointments or immediate customer needs using a "Sell One-Buy One" ordering pattern. Please refer to PANT Bulletin 09-12 for additional details.

(Parts Ordering Continued . . .)

A UIO by state matrix is listed below to inform dealers of the number of vehicles in their area.

STATE	UIO	STATE	UIO	STATE	UIO	STATE	UIO	STATE	UIO
AK	56	GA	297	ME	21	NJ	286	SD	13
AL	77	IA	87	MI	206	NM	25	TN	325
AR	62	ID	0	MN	177	NV	77	TX	511
AZ	10	IL	873	MO	121	NY	475	UT	7
CA	160	IN	179	MS	65	OH	528	VA	198
CO	16	KS	64	MT	1	OK	339	VT	16
CT	76	KY	316	NC	113	OR	8	WA	38
DC	6	LA	100	ND	16	PA	310	WI	169
DE	27	MA	232	NE	11	RI	44	WV	29
FL	170	MD	203	NH	37	SC	101	WY	2

6. Repair Procedures

Refer to TIS for the appropriate Technical Instructions.

NOTE: To conduct this Safety Recall, technicians will need to utilize the following SST:

1. **SST Taper Gauge (Gap Tool) 00002-GTMAR (drawer 20)**
2. **09017-1C100 - Union Nut Wrench 10mm**
3. **09017-1C110 - Union Nut Wrench 12mm**

7. Warranty Processor Instructions

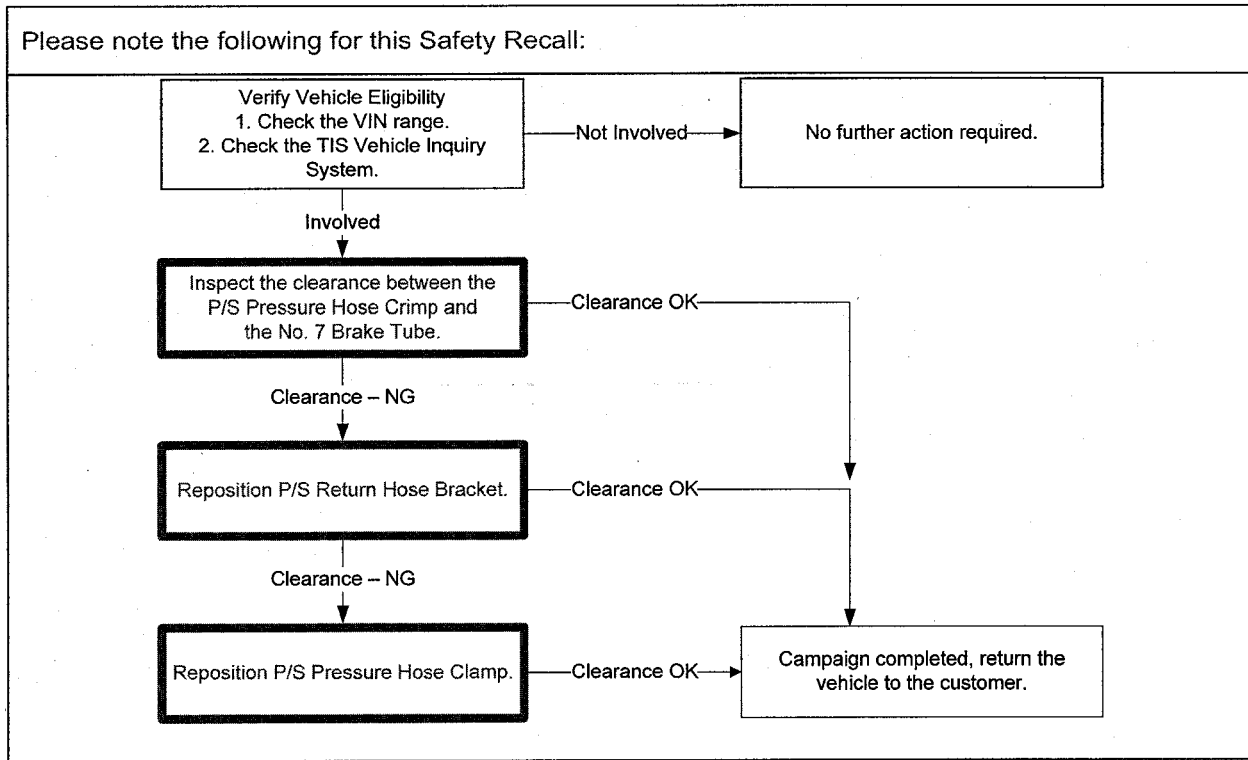

The operation codes to be used for this Safety Recall are:

Safety Recall #	Op. Code	Description	Flat Rate Hour
A0C	0522A1	Inspect the space between the brake tube and the power steering pressure hoses crimp.	0.3 hr/vehicle
A0C	0522A2	Inspect and Reposition the space between the brake tube and the power steering pressure hose crimp.	0.7 hr/vehicle
A0C	0522A3	Inspect and Reposition the space between the brake tube and the power steering pressure hose crimp & Replace the Front Brake Tube	2.1 hr/vehicle

NOTE:

- The above flat rate times include 0.1 hour for Safety Recall administrative cost per unit for the dealership.
- For Operation Code 0522A3, a one liter bottle of brake fluid (part number 00475-1BF03) may be included on the Safety Recall claim **if used during the repair**. Use "OF" sublet type. State "Brake Fluid" in the sublet description.
- Rental Car: Use "RT" sublet type for Op. Code 0522A3. Customer rental car through the Toyota Rent-A-Car (TRAC) Program is available for a maximum of 3 days at a maximum rate of \$35 per day. Special accommodations, not outlined above require DSPM authorization.

Submit Safety Recall claims following the procedures described in the Toyota Warranty Policy and Procedures Manual.

Please review this entire package with your Service and Parts staff to familiarize them with the proper step-by-step procedures required to implement this Safety Recall.

Thank you for your cooperation.
TOYOTA MOTOR SALES, U.S.A., INC.

**Safety Recall A0C – Certain Early Production 2010 Camry Vehicles Equipped with the 4 Cylinder Engine
Brake Tube Inspection
SAFETY RECALL NOTICE**

[VIN]

Dear Toyota Owner:

This notice is being sent to you in accordance with the requirements of the National Traffic and Motor Vehicle Safety Act. Toyota has decided that a defect which relates to motor vehicle safety exists in certain early production 2010 model year Camry vehicles equipped with the 4 cylinder engine.

What is the Condition?

On certain early production 2010 model year Camry vehicles equipped with the 4 cylinder (2AR-FE) engine, a power steering pressure hose in the engine compartment may be the incorrect length. If this condition exists, a crimp on the power steering pressure hose may come in contact with a specific brake tube ("brake tube").

Should this condition continue, a hole may wear in the brake tube and deplete the brake fluid in the vehicle. In the worst case, the brake pedal stroke will increase and lead to greater vehicle stopping distance, which may increase the risk of a crash.

What will Toyota do?

Any Toyota dealer will inspect and if necessary adjust the space between the brake tube and the power steering pressure hose crimp. Based upon the inspection results, the dealership may need to replace the brake tube. The inspection/adjustment and, if necessary, the brake tube replacement, will be performed at **NO CHARGE** to you.

What should you do?

This is an important Safety Recall

Please contact your authorized Toyota dealer to make an appointment to get your vehicle inspected as soon as possible. Most vehicles will only require an inspection which will take approximately 45 minutes. However, depending upon the dealer's work schedule and the inspection results, it may be necessary to make your vehicle available for a longer period of time.

If replacement of the brake tube becomes necessary, your dealership will need to order the parts specific to your vehicle. As these parts are not normally stocked by dealerships, it will take a few days for the dealer to receive them. The Toyota dealer will make every effort to assure your utmost convenience during this waiting period.

We request that you present this notice to the dealer at the time of your service appointment.

If you would like to update your vehicle ownership or contact information, please go to www.toyota.com/ownersupdate. You will need your full 17-digit Vehicle Identification Number (VIN) to input the new information.

What if you have other questions?

Your local Toyota dealer will be more than happy to answer any of your questions and set up an appointment to perform this important Safety Recall. If you require further assistance, you may contact the Toyota Customer Experience Center at 1-888-270-9371 Monday through Friday, 5:00 am to 6:00 pm, Saturday 7:00 am through 4:00 pm Pacific Time.

If you believe that the dealer or Toyota has failed or is unable to remedy the defect within a reasonable time, you may submit a complaint to the Administrator, National Highway Traffic Safety Administration, 1200 New Jersey Avenue S.E., Washington, DC 20590 or call the toll free Vehicle Safety Hot Line at 1-888-327-4236 (TTY: 1-800-424-9153), or go to <http://www.safercar.gov>.

If you are a vehicle lessor, Federal law requires that any vehicle lessor receiving this recall notice must forward a copy of this notice to the vehicle lessee within ten days.

We have sent this notice in the interest of your continued satisfaction with our products, and we sincerely regret any inconvenience this condition may have caused you.

Thank you for driving a Toyota.

Sincerely,

TOYOTA MOTOR SALES, U.S.A., INC.



Safety Recall A0C

Certain Early Production 2010 Model Year Camry Vehicles Equipped with a 4 Cylinder Engine Brake Tube Inspection and/or Repositioning

Q1: What is the condition?

A1: On certain early production 2010 model year Camry vehicles equipped with the 4 cylinder engine, a power steering pressure hose in the engine compartment may be the incorrect length. If this condition exists a crimp on the power steering pressure hose may come in contact with the No. 7 Front Brake Tube ("brake tube").

Should this condition continue, a hole may wear in the brake tube and deplete the brake fluid in the vehicle. As a result, the brake pedal stroke will increase and lead to greater vehicle stopping distance.

Q2: Are there any warnings that this condition exists?

A2: No, there are no specific warnings that this condition exists.

Q3: What is Toyota going to do?

Q3: Any Toyota dealer will inspect and if necessary adjust the space between the brake tube and the power steering pressure hose crimp. Based upon the inspection results, in a limited number of cases the dealership may need to replace the brake tube. The inspection/adjustment and, if necessary, the brake tube replacement, will be performed at **NO CHARGE** to the vehicle owner.

Q4: When will owners be notified?

Q4: Toyota will notify owners by first class mail starting in mid-February, 2010.

Q5: Which and how many vehicles are involved?

A5: There are approximately 7,314 Camry vehicles involved in the U.S.

Q6: What is the production period of the affected vehicles?

A6: The affected Camry vehicles were produced from early February, 2009 to late March, 2009.

Q7: Are there any other Toyota or Lexus vehicles involved?

A7: No, this specific condition only affects certain early production 2010 model year Camry vehicles equipped with the 4 cylinder engine.

Q8: How long will the inspection take?

A8: The inspection will take approximately 45 minutes. However, depending upon the dealer's work schedule and the inspection results, it may be necessary to make the vehicle available for a longer period of time.

Q8a: What if replacement of the Brake Tube becomes necessary. How long will the repair take?

A8b: As these parts are not normally stocked by dealerships, it will take a few days for the dealer to order and receive them. The Toyota dealer will make every effort to assure each customer's utmost convenience during this waiting period.

Q9: What should an owner do if they experience the condition or have immediate concerns about the current safety of their vehicle?

A9: If an owner has immediate concerns they are requested to contact their local Toyota dealer for inspection and if applicable repair.

Owners may also contact the Toyota Customer Experience Center (1-800-331-4331) for additional assistance.

TECHNICAL INSTRUCTIONS

FOR

SAFETY RECALL A0C

**CLEARANCE INSPECTION BETWEEN THE P/S PRESSURE HOSE CRIMP
AND THE NO. 7 BRAKE TUBE**

**2010 CAMRY
4-CYLINDER ENGINE ONLY (2AR-FE)**

I. OPERATION FLOW CHART

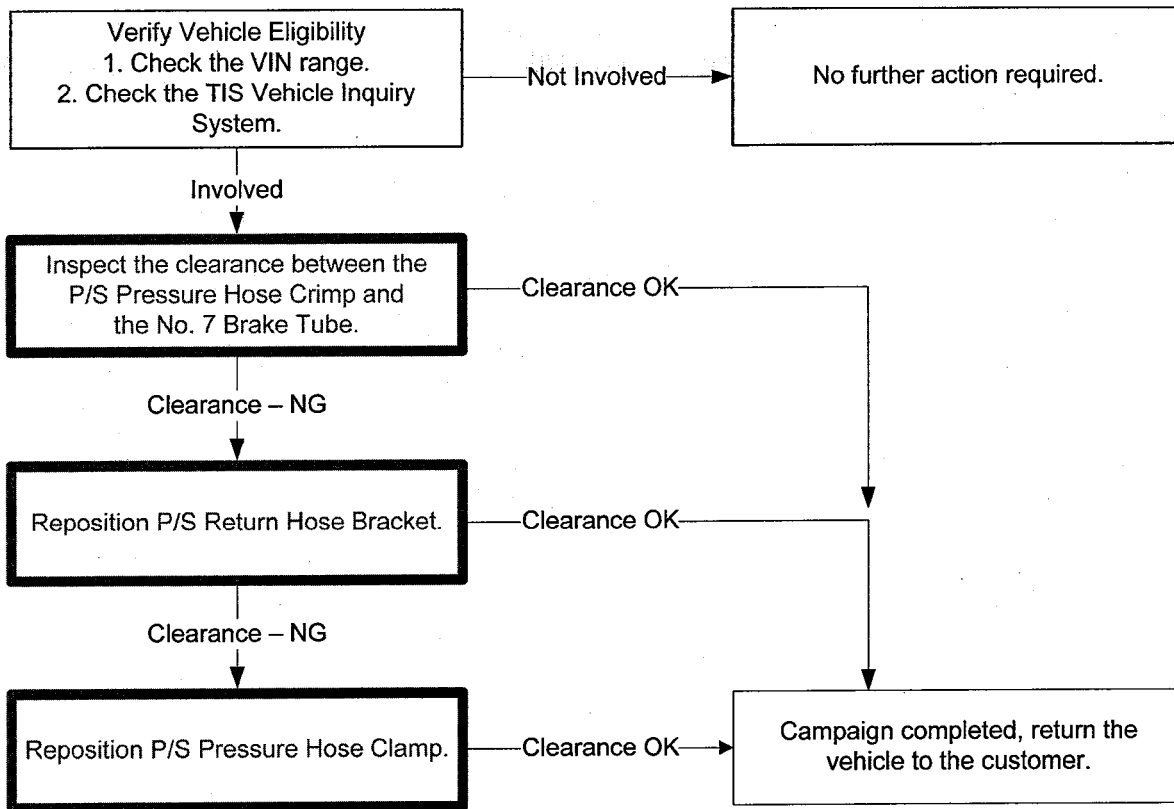

II. IDENTIFICATION OF AFFECTED VEHICLES

A. AFFECTED VIN RANGE

Model	WMI	Year	VIN Range	
			VDS	Range
CAMRY	4T1	2010	BF3EK	U001018 – U001021
				U500012 – U503263
	4T4			R001024 – R012346

- Check Dealer Daily/TIS to confirm the VIN is involved in this SSC. This will verify the vehicle is affected and has not already been completed prior to dealer shipment or by another dealer.
- TMS warranty will not reimburse dealers for repairs conducted on vehicles that are not affected or were completed by another dealer.

III. PREPARATION

A. TOOLS & MATERIALS

- Standard hand tools
- Special Service Tool (SST) 00002-GTMAR – Taper Gauge (Gap Tool) (drawer 20)
- Super Glue

IV. BACKGROUND

On 7,314 specific early production 2010 MY Camry vehicles equipped with the 4 cylinder (2AR-FE) engine, a P/S pressure hose in the engine compartment may be too long. If this condition exists a crimp on the P/S hose may come in contact with the No.7 brake tube. The safety recall will entail inspection and if necessary repositioning the P/S return hose bracket and/or P/S pressure hose clamp.

V. WORK PROCEDURE

A. MEASURE CLEARANCE

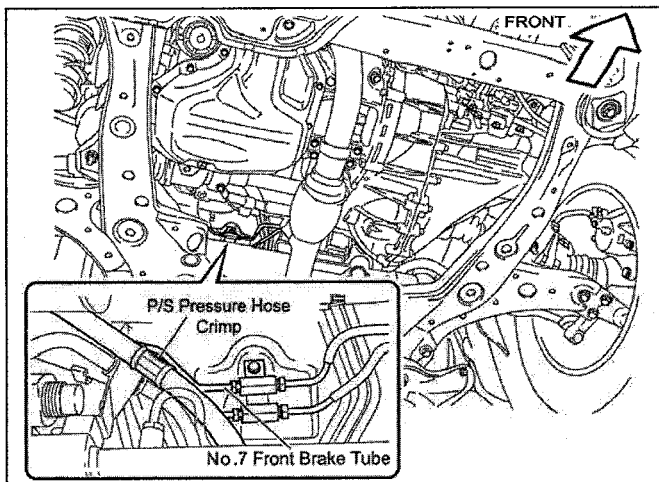

1. LOCATE P/S PRESSURE HOSE CRIMP

2. MEASURE THE CLEARANCE BETWEEN THE P/S PRESSURE HOSE CRIMP AND THE NO. 7 FRONT BRAKE TUBE

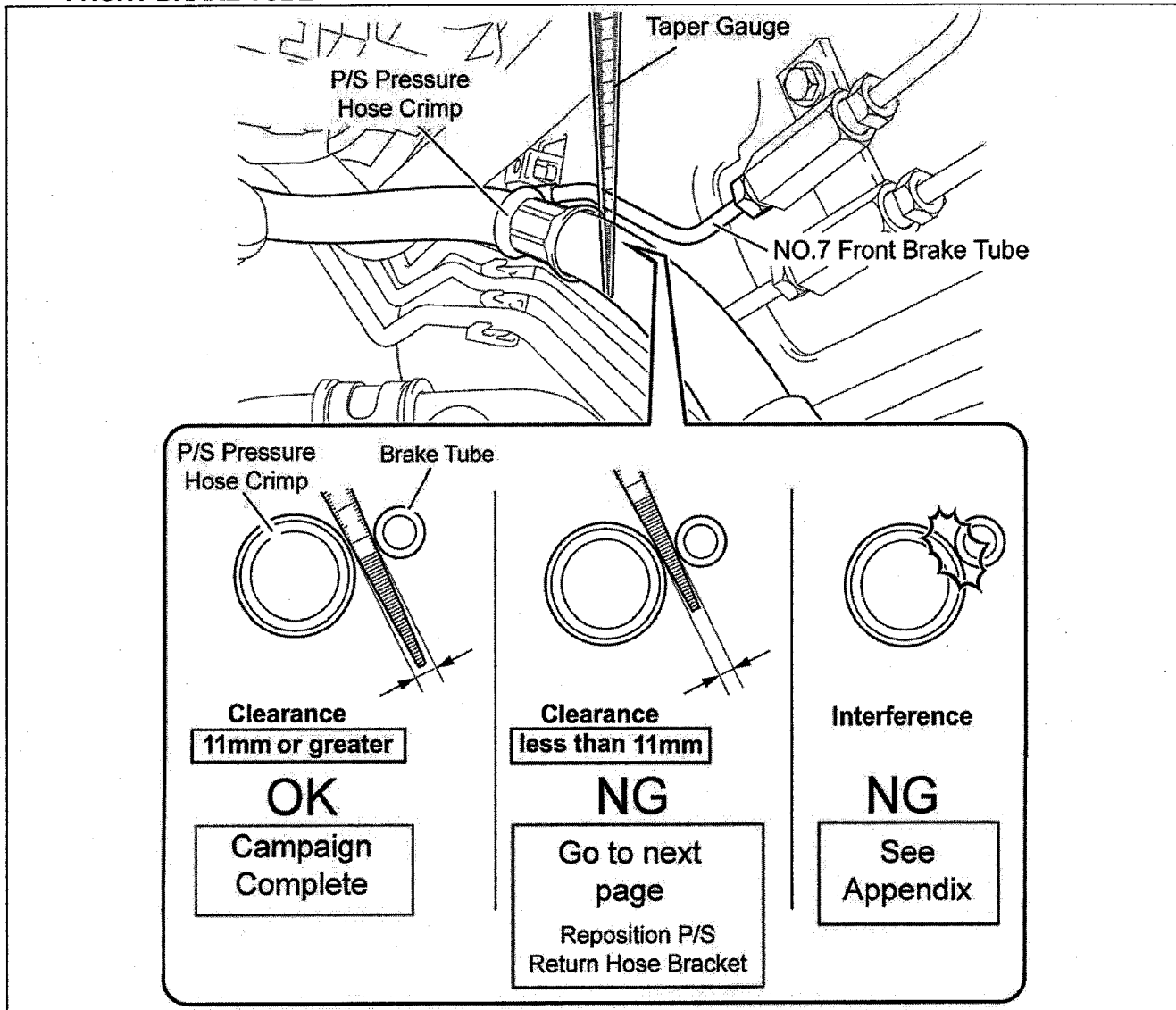

B. REPOSITION P/S RETURN HOSE BRACKET

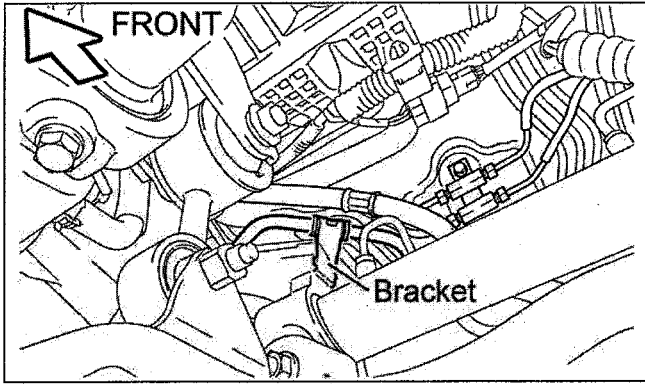

1. LOCATE THE P/S RETURN HOSE BRACKET

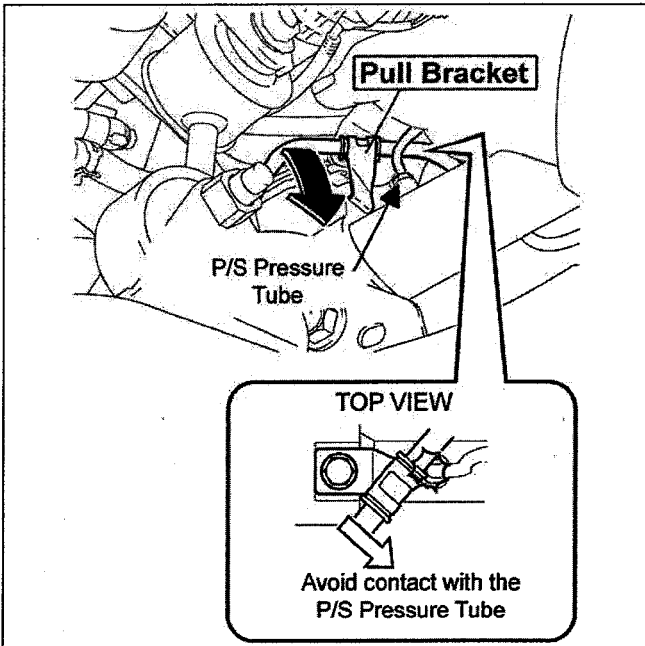

2. REPOSITION BRACKET POSITION

- Carefully bend the bracket towards the front of the vehicle and down.
- Stop before contact is made with the P/S pressure tube.

NOTES:

- Only bend the bracket - Not the P/S return hose.
- 3mm of clearance must be maintained between the P/S pressure tube and the P/S return hose.

C. RE-MEASURE CLEARANCE BETWEEN THE P/S PRESSURE HOSE CRIMP AND THE NO. 7 FRONT BRAKE TUBE

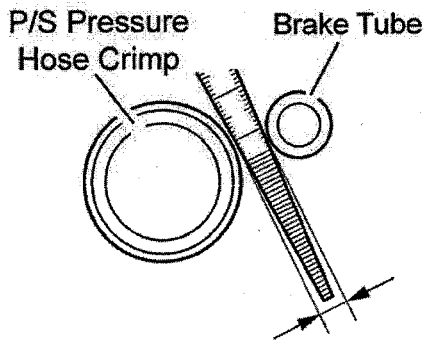
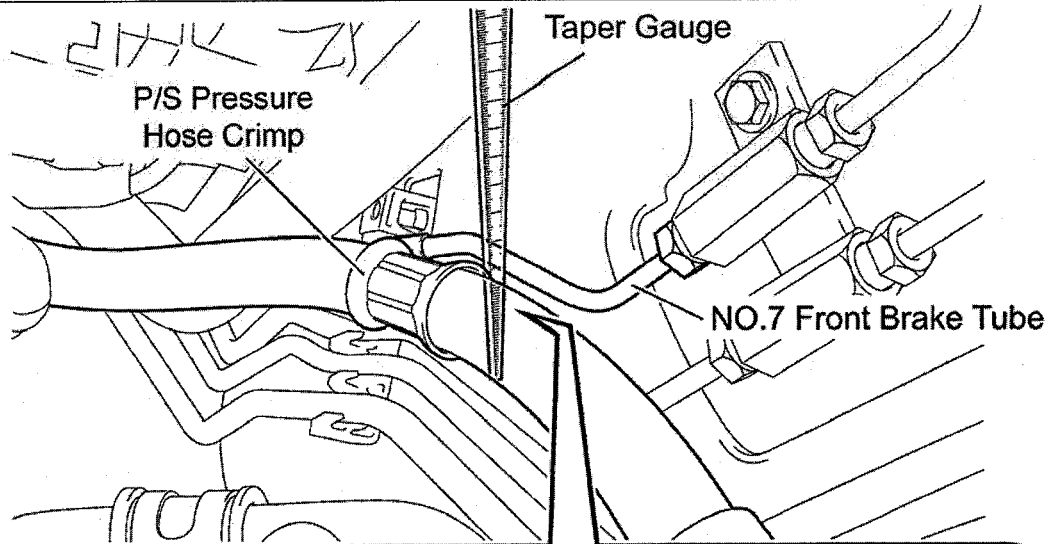

Clearance
11mm or greater

OK
Campaign
Complete

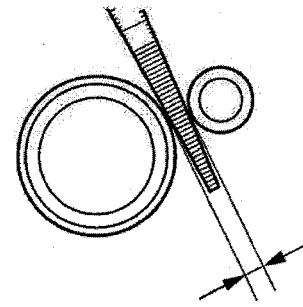

Clearance
less than 11mm

NG
Go to next
page
Reposition the P/S
Pressure Hose Clamp

D. REPOSITION THE P/S PRESSURE HOSE CLAMP

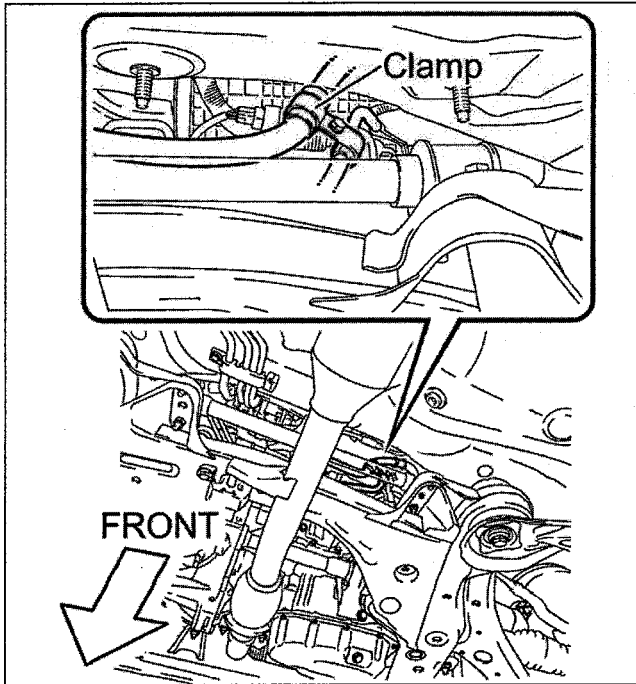

1. LOCATE P/S PRESSURE HOSE CLAMP

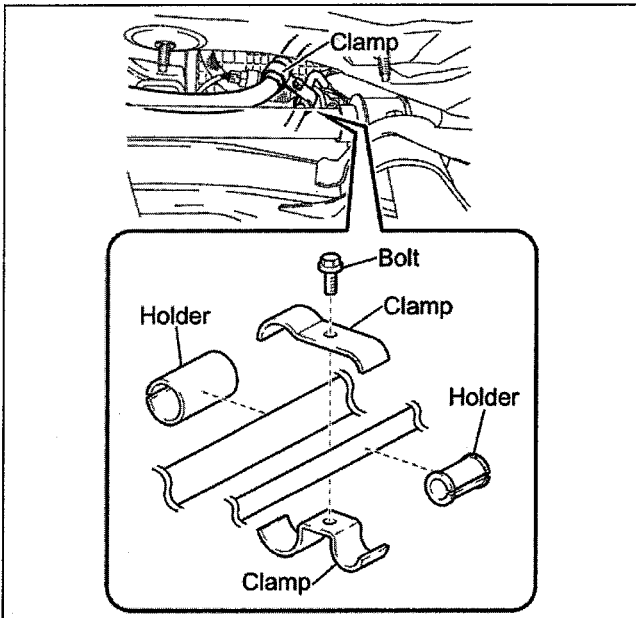

2. REMOVE CLAMP AND HOLDER

- Remove the bolt.
- Remove both halves of the clamp and the holders.
- Clean the clamp, holders and hoses with warm water. Dry the components.

NOTE:

- The clamp, holders and hoses are lightly glued together from the factory.
- To avoid damage, be careful not to pull too hard on the hoses during disassembly.

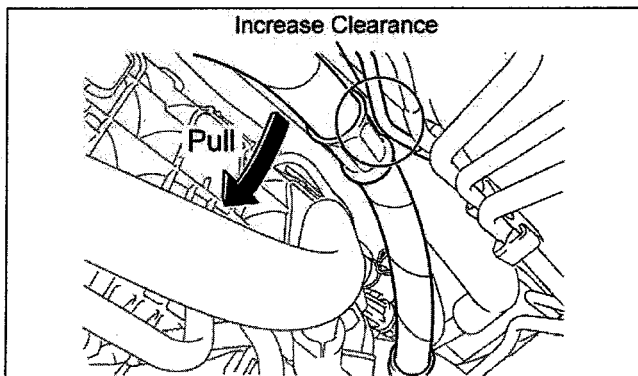

3. REPOSITION POSITION OF P/S PRESSURE HOSE ASSEMBLY

- Pull the P/S pressure hose away from the No. 7 brake tube by 11-15 mm (approx. 1/2 inch).

STOP

Steps b) through e) must be performed before the glue dries.

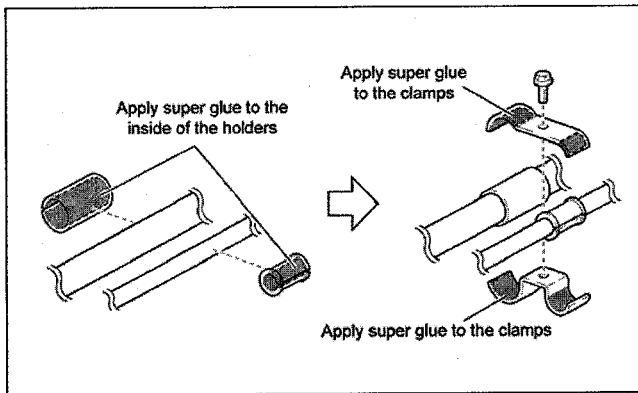

- b) Lightly glue the 2 holders to the same location from where they were removed on the hoses.
- c) Lightly glue the clamp to the holders.
- d) While holding the hose in the proper position (approx. 1/2 inch from the brake tube), fasten the bolt.

Bolt Torque Specification:
5.5 N·m (56 kgf·cm, 49 in·lbf)

NOTE:
The glue is necessary to keep the hoses in the correct orientation after the adjustment.

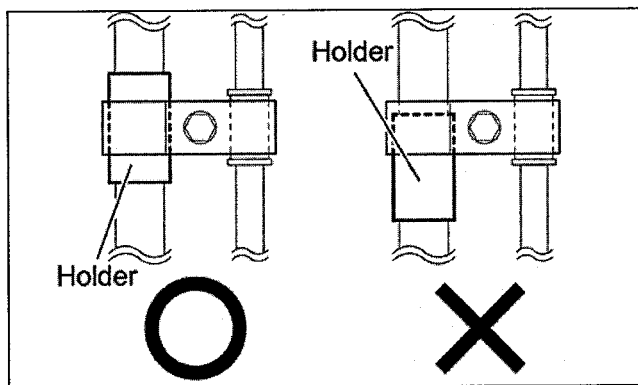

- e) Verify the clamp is directly on the holders.

NOTE:
If the clamp is not directly on the holders readjust the position as it may wear the power steering hoses.

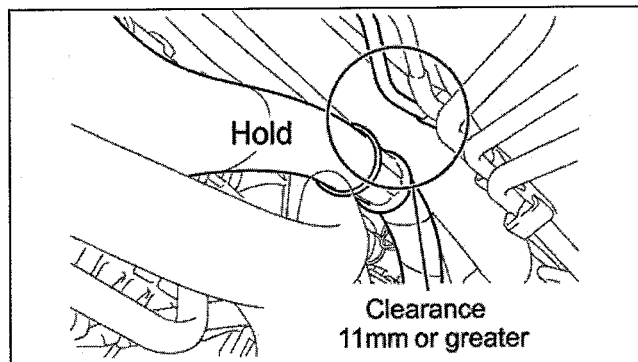

- f) Hold the P/S pressure hose in place to maintain sufficient clearance until the glue is set.

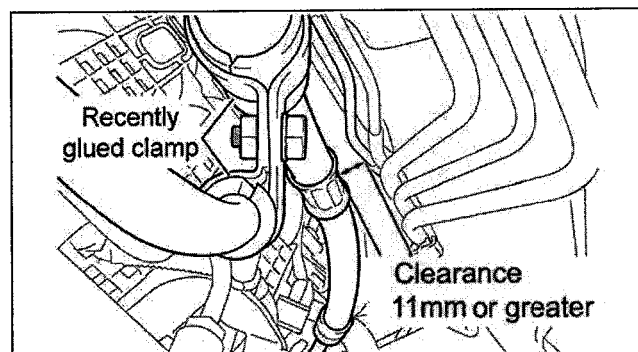

- g) Verify that at least an 11mm clearance exists between the P/S pressure hose crimp and the no. 7 brake tube.

NOTE:
If the clearance is still less than 11mm, re-perform steps B & D.

-Campaign Complete-

VI. APPENDIX

Work Procedure - No.7 Front Brake Tube Installation



Replacement of the brake tube is only necessary when interference or scuffing has been identified on the No. 7 front brake tube according to the inspection (p. 2)

A. PARTS

Part Number	Part Description	Quantity
47317-06160	No.7 Front Brake Tube	1

B. TOOLS & EQUIPMENT

- Standard hand tools
- Torque Wrench
- Brake Bleeder
- Union Nut Wrench 10mm & 12mm

C. MATERIALS

- Toyota DOT 3 Brake Fluid

D. COMPONENTS

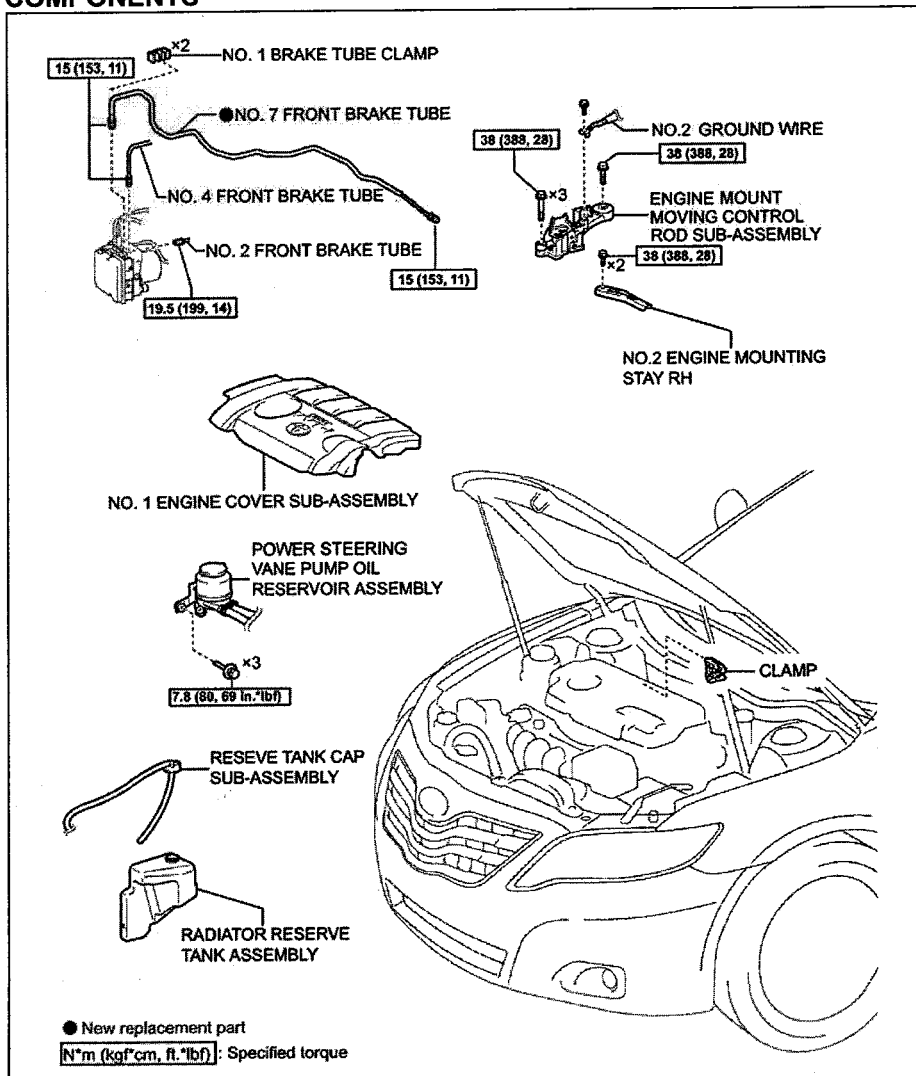

DO NOT FORGET TO PERFORM THE WORK PROCEDURE STARTING ON PAGE 2
AFTER REPLACING THE NO. 7 FRONT BRAKE TUBE.

E. REMOVE NO.7 FRONT BRAKE TUBE -

1. DRAIN BRAKE FLUID
2. REMOVE NO. 1 ENGINE COVER SUB-ASSEMBLY
3. REMOVE THE RADIATOR RESERVE TANK ASSEMBLY

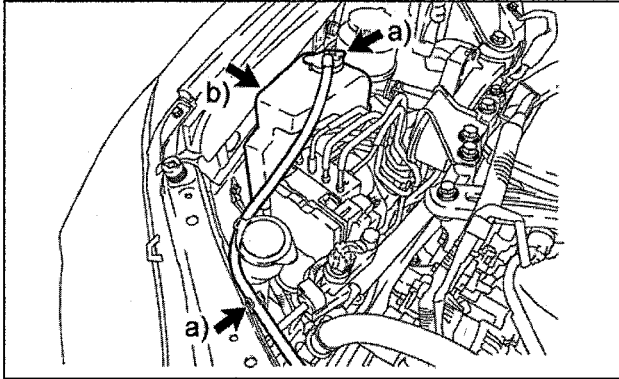

- a) Separate the radiator reservoir tank cap and hose.
- b) Remove the radiator reserve tank assembly.

4. REMOVE THE ENGINE MOUNT

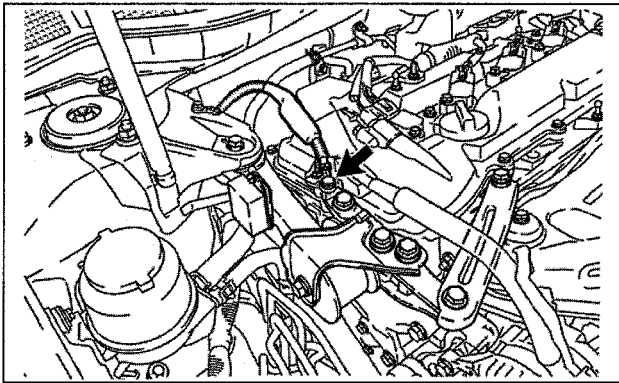

- a) Remove the bolt and separate No.2 ground wire.

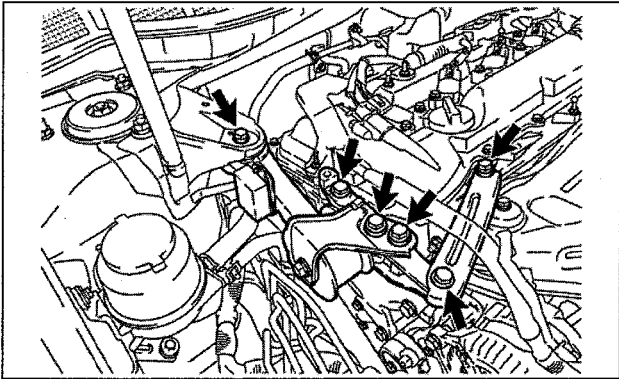

- b) Remove the 6 bolts and the No.2 engine mounting stay RH and engine mount.

5. SEPARATE THE A/C LINE CLAMPS

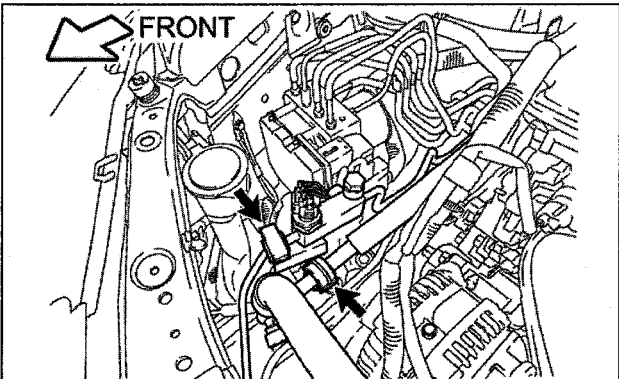

- a) Disengage the 2 clamps and separate the two air conditioner lines shown.

NOTE:

Disengaging the clamps from the A/C lines is necessary to provide clearance for brake tube removal.

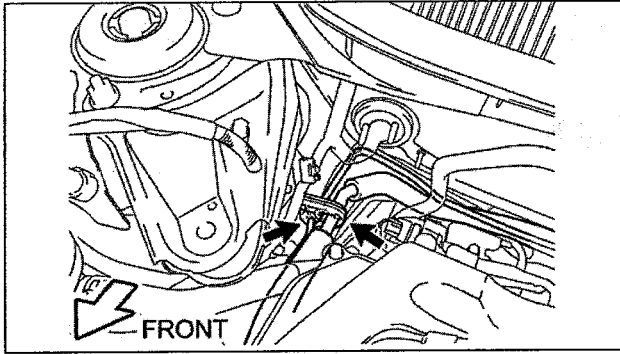

- b) Remove the clamp and disengage the air conditioning lines.

HINT:

Access the back of the clamp from the right front wheel-well to release the clamp claws.



Carefully and correctly identify each brake tube to ensure correct reinstallation. This is critical to prevent brake system damage.

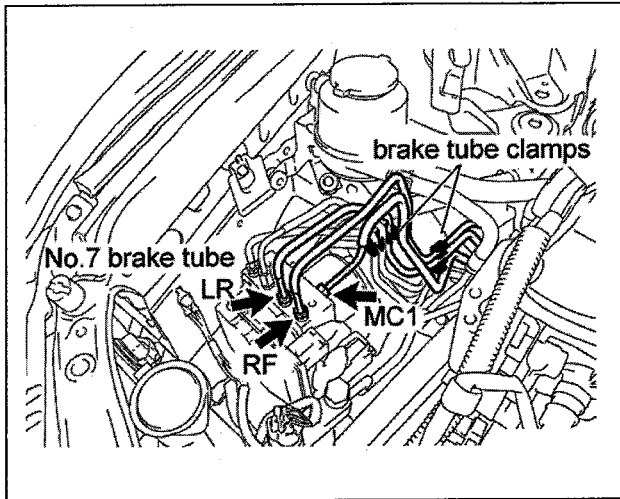

6. REMOVE THE NO.7 FRONT BRAKE TUBE

- a) Clearly identify the brake tubes using tags or markings.
 - LR (No. 7 brake tube)
 - RF brake tube
 - MC1 brake tube
- b) Clearly identify the two brake tube clamp locations in relation to the brake tubes.
- c) Remove both brake tube clamps.
- d) Remove the 3 brake tubes from the brake actuator assembly.

NOTE:

All 3 tubes must be removed to allow clearance for the No.7 front brake tube.

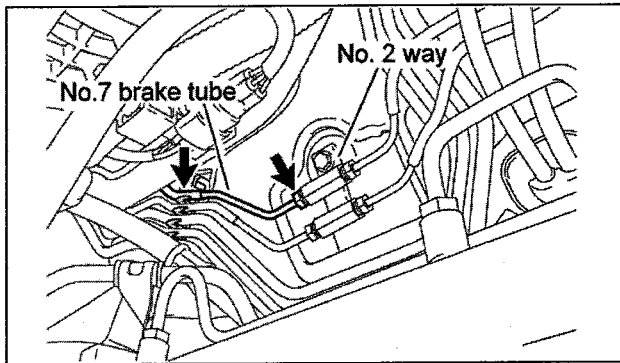

- e) Disconnect No.7 brake tube from the No.2 way located on the bulk head.
- f) Disconnect the brake tube from the clamp.

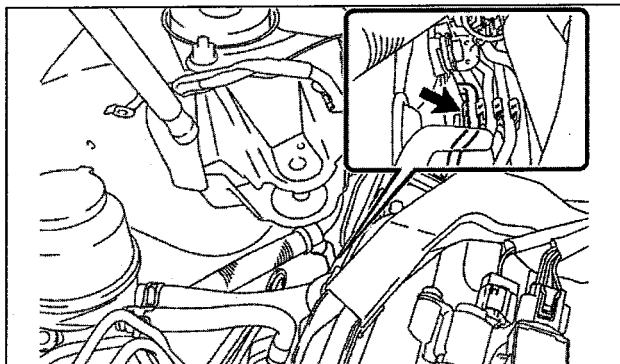

- g) Disconnect the No.7 brake tube from the clamp.

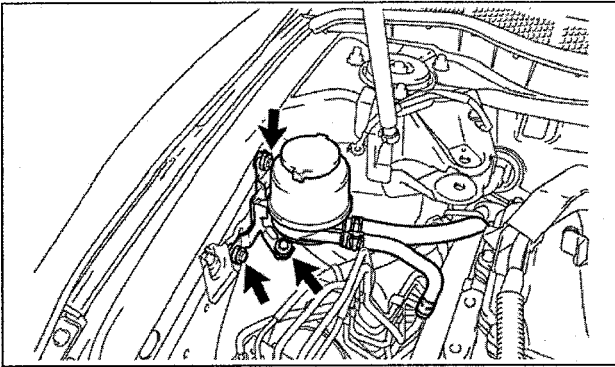

- h) Remove the 3 bolts and move the power steering reservoir aside to provide the necessary clearance for the brake tube removal.
- i) Remove the No.7 brake tube from the engine compartment.

F. INSTALL THE NEW NO.7 FRONT BRAKE TUBE

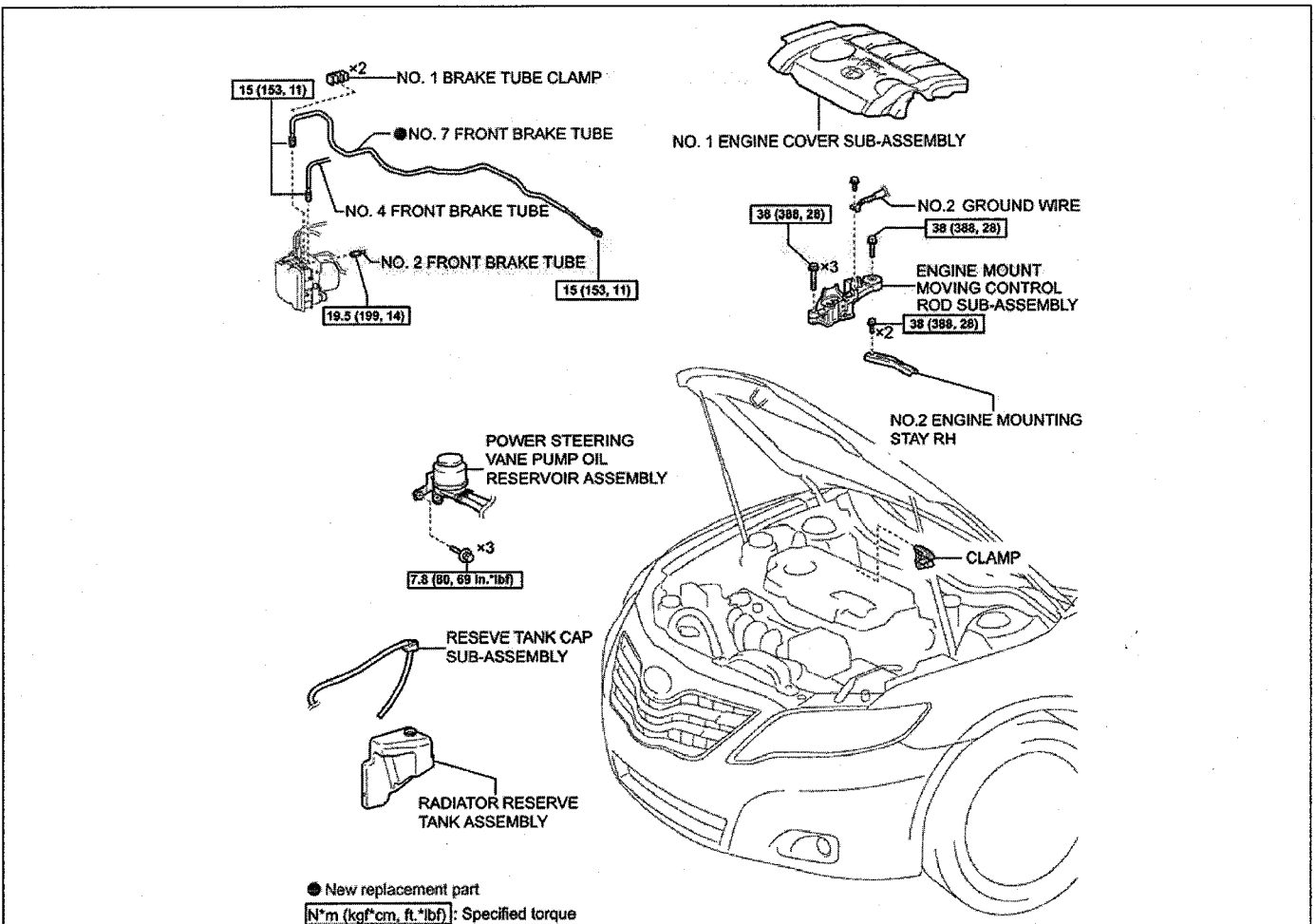

1. INSTALL THE COMPONENTS IN THE REVERSE ORDER OF REMOVAL.
2. FILL RESERVOIR WITH BRAKE FLUID
3. BLEED BRAKE LINES Click link for detail: [BRAKE: BRAKE FLUID: BLEEDING](#)
4. INSPECT FOR BRAKE FLUID LEAKS – VERIFY CORRECT FLUID LEVEL IN RESERVOIR

5. RETURN TO PAGE 2 - PERFORM THE WORK PROCEDURE PREVENT ADDITIONAL INTERFERENCE WITH THE NO. 7 BRAKE TUBE.

TOYOTA CUSTOMER SERVICES

Volume: XVI
Number: TC10-009
Date: 2/11/2010
 Action
 Retain
 Information

INTEROFFICE MEMORANDUM

To: All Region/Private Distributor General Managers/Vice Presidents

From: Bob Waltz, *BWaltz*
Vice President, Product Quality and Service Support

Subject: Safety Recall – A0C
Certain Early Production 2010 Model Year Camry Vehicles
Equipped with 4 Cylinder (2AR-FE) Engines
Brake Tube Inspection and/or Repositioning

On February 9, 2010, Toyota filed a Defect Information Report (DIR) with the National Highway Traffic Safety Administration (NHTSA) informing the agency of our intent to conduct a voluntary Safety Recall on certain early production 2010 Model Year Toyota Camry vehicles equipped with the 4 cylinder (2AR-FE) engines.

Condition

On **7,314** early production 2010 model year Camry vehicles equipped with the 4 cylinder (2AR-FE) engine, a power steering pressure hose in the engine compartment may be the incorrect length. If this condition exists, a crimp on the power steering pressure hose may come in contact with the No. 7 Front Brake Tube (“brake tube”). Should this condition continue, a hole may wear in the brake tube and deplete the brake fluid in the vehicle. As a result, the brake pedal stroke will increase and lead to greater vehicle stopping distance.

Safety Recall Remedy

We request Toyota dealers to inspect and if necessary adjust the space between the brake tube and the power steering pressure hose crimp on the affected vehicles. Based upon the inspection results, the brake tube may need to be replaced. The inspection/adjustment and, if necessary, the brake tube replacement, will be performed at **NO CHARGE** to the vehicle owner.

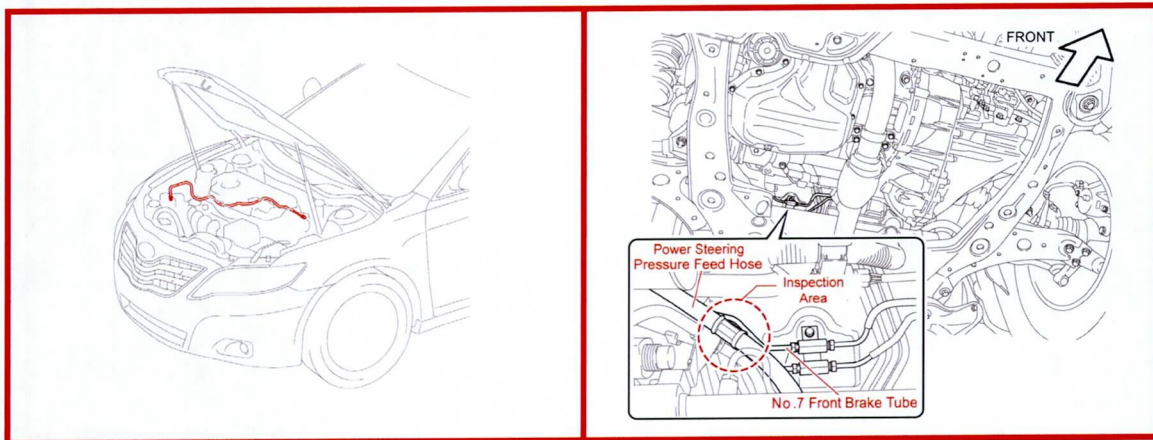

1. Dealer Letter Mailing Date

The attached Dealer Letter will be sent to all Toyota dealers in early February, 2010.

2. Owner Notification Mailing Date

The owner notification will commence in mid-February, 2010.

Please note that only owners of the specific 7,314 vehicles will be notified. If a dealer is contacted by an owner, who has not yet received a notification, please instruct the dealer to **verify eligibility by confirming through Dealer Daily/TIS prior to performing repairs**. Dealers should perform the repair as outlined in the Technical Instructions found on TIS.

3. Number of Vehicles Involved

There are 7,314 Camry (2010 model year) vehicles involved.

4. Region/District Summary Reports

We have enclosed the following Safety Recall A0C Summary Reports in the Region/Private Distributor (PD) Service Manager/Customer Service Operations Manager/Director of Service Package:

- Region/PD Summary that provides an overview of the entire Region/PD for this Safety Recall.
- District Summary Report that indicates the number of involved vehicles registered in each dealership's primary marketing area for this Safety Recall.
- **Dealer Reports will no longer contain a PMA VIN list.** However, they will contain the number of involved vehicles in dealer stock.

cc: Region/Private Distributor Assistant General Managers
Region/Private Distributor Customer Service Operations Managers
Region/Private Distributor Service Managers/Directors/VPs
Region/Private Distributor Parts Managers/Directors/VPs
Region/Private Distributor Customer Services Field Managers
Region/Private Distributor Technical Services and Training Managers
Region/Private Distributor District Service and/or Parts Managers
Region/Private Distributor Customer Relations Managers
Region/Private Distributor PDC Managers
Region/Private Distributor Field Technical Specialists
Region/Private Distributor Service Training Specialists
Region/Private Distributor Vehicle Operations Managers
All NAPC General Managers
All TMS Sales Administration Managers
All TMS Product Quality & Service Support Managers
All Field Product Engineers

J. Beseda	W. Fay	K. Kusakawa	S. Sugawara
G. Borst	N. Fein	M. Michels	M. Templin
R. Broughman	F. Fontanella	T. Morrison	J. Tetherow
G. Bryan	H. Fukui	T. Nakagami	P. Uribe
W. Burns	S. Haag	D. Pettitt	K. Ura
D. Camden	J. Hanson	R. Pflughaupt	A. Vaish
B. Carter	K. Higgins	C. Reynolds	R. Waltz
G. Christoff	C. Hostetter	C. Roberts	S. Yamaguchi
J. Colon	M. Hosoe	R. Sakai	M. Yamanami
B. Cooper	Y. Inaba	D. Sakakibara	N. Yamamoto
R. Daly	M. King	M. Setta	H. Yoshihashi
F. Davidson	J. Lang	A. Smith	D. Zellers
T. Doi	J. Lentz	R. Specht	
D. Esmond	E. Matsuda	J. Stempkowski	

To: All Toyota Dealer Principals, Service Managers, Parts Managers

Subject: Safety Recall – A0C
Certain Early Production 2010 Model Year Camry Vehicles
Equipped with 4 Cylinder (2AR-FE) Engines
Brake Tube Inspection and/or Repositioning

On February 9, 2010, Toyota filed a Defect Information Report (DIR) with the National Highway Traffic Safety Administration (NHTSA) informing the agency of our intent to conduct a voluntary Safety Recall on certain early production 2010 Model Year Toyota Camry vehicles equipped with the 4 cylinder (2AR-FE) engines.

Condition

On **7,314** early production 2010 model year Camry vehicles equipped with the 4 cylinder (2AR-FE) engine, a power steering pressure hose in the engine compartment may be the incorrect length. If this condition exists, a crimp on the power steering pressure hose may come in contact with the No. 7 Front Brake Tube (“brake tube”). Should this condition continue, a hole may wear in the brake tube and deplete the brake fluid in the vehicle. As a result, the brake pedal stroke will increase and lead to greater vehicle stopping distance.

Safety Recall Remedy

We request Toyota dealers to inspect and if necessary adjust the space between the brake tube and the power steering pressure hose crimp on the affected vehicles. Based upon the inspection results, the brake tube may need to be replaced. The inspection/adjustment and, if necessary, the brake tube replacement, will be performed at **NO CHARGE** to the vehicle owner.

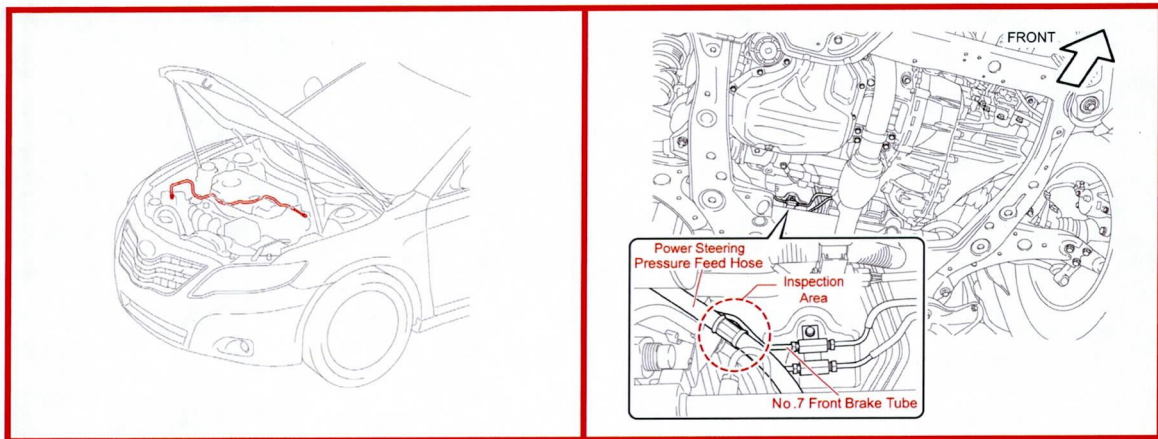

1. Owner Notification Letter Mailing Date

The owner notification will commence in mid-February, 2010.

Please note that only owners of the specific 7,314 vehicles will be notified. If your dealership is contacted by an owner of an involved vehicle, who has not yet received a notification, please **verify eligibility by confirming through Dealer Daily/TIS prior to performing repairs**. Dealers should perform the repair as outlined in the attached Technical Instructions.

2. Vehicles in Dealer Stock

As required by Federal law, dealers are not to deliver any new vehicles in their inventory, which are involved in this Safety Recall. Dealers must perform the Safety Recall on all new vehicles in stock prior to sale or lease. Vehicle Safety Recall completion can be verified through TIS.

3. Dealer/Owner Lists

Summary Reports containing the **number** of involved vehicles in your dealership's primary marketing area and a VIN list containing vehicles in dealer stock have been distributed to each dealership's Service and Parts Manager. (VIN lists of vehicles in the dealership's PMA will no longer be provided. Please verify eligibility by confirming through Dealer Daily or TIS prior to performing repairs.)

4. Number and Identification of Involved Vehicles

There are 7,314 specific Camry (2010 model year) vehicles involved.

Model	WMI	MY	VIN Range	
			VDS	Range
Camry	4T1	2010	BF3EK	U001018 – U001021
				U500012 – U503263
	4T4			R001024 - R012346

5. Parts Ordering

It is anticipated that this inspection and if necessary repositioning will not require any parts. In the unlikely event that the No. 7 Front Brake Tube requires replacement, the following part will need to be ordered. It will be placed on Manual Allocation Control (MAC) until further notice. While the parts are on MAC, a representative from TMS will review each order and contact the dealership's Parts Manager as required, to verify the necessity of the order. This will assure an adequate and balanced parts inventory.

If there are questions regarding operational or logistical issues, dealership associates should go through their normal channels for resolution (e.g. PDC, Dealer Parts Call Center for TMS Region Dealers, DSPMs).

If there are special circumstances where a dealership requires parts release, dealership associates should contact (310) 468-5516. The associate should have the following information ready to expedite research of the order status:

1. Dealer Information (Dealer Code, Contact Name, Telephone Number)
2. Order Reference Number
3. Customer Name and Vehicle 17-digit VIN

Part No.	Part Name	Qty/Unit
47317-06160*	No. 7 Front Brake Tube	1*

 ***Part replacement is based on inspection results. DO NOT order parts until the vehicle inspection has been completed. Refer to the Technical Instructions posted on TIS for additional information.**

IMPORTANT PARTS ORDERING REMINDER

Effective March 1, 2009, Safety Recall Service Campaign (SSC/LSC) and Customer Support Program (CSP) parts do not earn Parts Return Credit Accrual and are not returnable under the Monthly Return Program. It is recommended that you order these parts based on appointments or immediate customer needs using a "Sell One-Buy One" ordering pattern. Please refer to PANT Bulletin 09-12 for additional details.

(Parts Ordering Continued . . .)

A UIO by state matrix is listed below to inform dealers of the number of vehicles in their area.

STATE	UIO	STATE	UIO	STATE	UIO	STATE	UIO	STATE	UIO
AK	56	GA	297	ME	21	NJ	286	SD	13
AL	77	IA	87	MI	206	NM	25	TN	325
AR	62	ID	0	MN	177	NV	77	TX	511
AZ	10	IL	873	MO	121	NY	475	UT	7
CA	160	IN	179	MS	65	OH	528	VA	198
CO	16	KS	64	MT	1	OK	339	VT	16
CT	76	KY	316	NC	113	OR	8	WA	38
DC	6	LA	100	ND	16	PA	310	WI	169
DE	27	MA	232	NE	11	RI	44	WV	29
FL	170	MD	203	NH	37	SC	101	WY	2

6. Repair Procedures

Refer to TIS for the appropriate Technical Instructions.

NOTE: To conduct this Safety Recall, technicians will need to utilize the following SST:

1. SST Taper Gauge (Gap Tool) 00002-GTMAR (drawer 20)
2. 09017-1C100 - Union Nut Wrench 10mm
3. 09017-1C110 - Union Nut Wrench 12mm

7. **Warranty Processor Instructions**

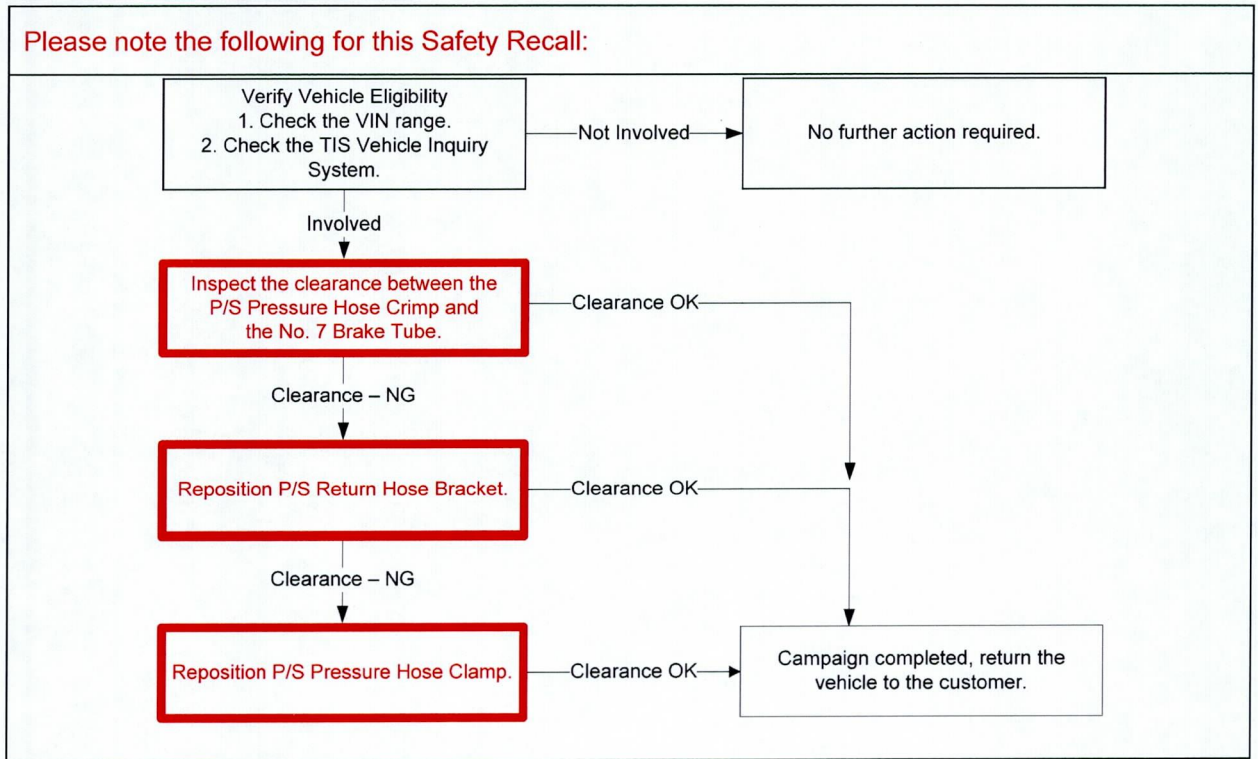

The operation codes to be used for this Safety Recall are:

Safety Recall #	Op. Code	Description	Flat Rate Hour
A0C	0522A1	Inspect the space between the brake tube and the power steering pressure hoses crimp.	0.3 hr/vehicle
A0C	0522A2	Inspect and Reposition the space between the brake tube and the power steering pressure hose crimp.	0.7 hr/vehicle
A0C	0522A3	Inspect and Reposition the space between the brake tube and the power steering pressure hose crimp & Replace the Front Brake Tube	2.1 hr/vehicle

NOTE:

- The above flat rate times include 0.1 hour for Safety Recall administrative cost per unit for the dealership.
- For Operation Code 0522A3, a one liter bottle of brake fluid (part number 00475-1BF03) may be included on the Safety Recall claim **if used during the repair**. Use "OF" sublet type. State "Brake Fluid" in the sublet description.
- Rental Car: Use "RT" sublet type for Op. Code 0522A3. Customer rental car through the Toyota-Rent-A-Car (TRAC) Program is available for a maximum of 3 days at a maximum rate of \$35 per day. Special accommodations, not outlined above require DSPM authorization.

Submit Safety Recall claims following the procedures described in the Toyota Warranty Policy and Procedures Manual.

Please review this entire package with your Service and Parts staff to familiarize them with the proper step-by-step procedures required to implement this Safety Recall.

Thank you for your cooperation.
TOYOTA MOTOR SALES, U.S.A., INC.

**Safety Recall A0C – Certain Early Production 2010 Camry Vehicles Equipped with the 4 Cylinder Engine
Brake Tube Inspection
SAFETY RECALL NOTICE**

[VIN]

Dear Toyota Owner:

This notice is being sent to you in accordance with the requirements of the National Traffic and Motor Vehicle Safety Act. Toyota has decided that a defect which relates to motor vehicle safety exists in certain early production 2010 model year Camry vehicles equipped with the 4 cylinder engine.

What is the Condition?

On certain early production 2010 model year Camry vehicles equipped with the 4 cylinder (2AR-FE) engine, a power steering pressure hose in the engine compartment may be the incorrect length. If this condition exists, a crimp on the power steering pressure hose may come in contact with a specific brake tube ("brake tube").

Should this condition continue, a hole may wear in the brake tube and deplete the brake fluid in the vehicle. In the worst case, the brake pedal stroke will increase and lead to greater vehicle stopping distance, which may increase the risk of a crash.

What will Toyota do?

Any Toyota dealer will inspect and if necessary adjust the space between the brake tube and the power steering pressure hose crimp. Based upon the inspection results, the dealership may need to replace the brake tube. The inspection/adjustment and, if necessary, the brake tube replacement, will be performed at **NO CHARGE** to you.

What should you do?

This is an important Safety Recall

Please contact your authorized Toyota dealer to make an appointment to get your vehicle inspected as soon as possible. Most vehicles will only require an inspection which will take approximately 45 minutes. However, depending upon the dealer's work schedule and the inspection results, it may be necessary to make your vehicle available for a longer period of time.

If replacement of the brake tube becomes necessary, your dealership will need to order the parts specific to your vehicle. As these parts are not normally stocked by dealerships, it will take a few days for the dealer to receive them. The Toyota dealer will make every effort to assure your utmost convenience during this waiting period.

We request that you present this notice to the dealer at the time of your service appointment.

If you would like to update your vehicle ownership or contact information, please go to www.toyota.com/ownersupdate. You will need your full 17-digit Vehicle Identification Number (VIN) to input the new information.

What if you have other questions?

Your local Toyota dealer will be more than happy to answer any of your questions and set up an appointment to perform this important Safety Recall. If you require further assistance, you may contact the Toyota Customer Experience Center at 1-888-270-9371 Monday through Friday, 5:00 am to 6:00 pm, Saturday 7:00 am through 4:00 pm Pacific Time.

If you believe that the dealer or Toyota has failed or is unable to remedy the defect within a reasonable time, you may submit a complaint to the Administrator, National Highway Traffic Safety Administration, 1200 New Jersey Avenue S.E., Washington, DC 20590 or call the toll free Vehicle Safety Hot Line at 1-888-327-4236 (TTY: 1-800-424-9153), or go to <http://www.safercar.gov>.

If you are a vehicle lessor, Federal law requires that any vehicle lessor receiving this recall notice must forward a copy of this notice to the vehicle lessee within ten days.

We have sent this notice in the interest of your continued satisfaction with our products, and we sincerely regret any inconvenience this condition may have caused you.

Thank you for driving a Toyota.

Sincerely,

TOYOTA MOTOR SALES, U.S.A., INC.

SAMPLE



Safety Recall A0C

Certain Early Production 2010 Model Year Camry Vehicles Equipped with a 4 Cylinder Engine Brake Tube Inspection and/or Repositioning

Q1: What is the condition?

A1: On certain early production 2010 model year Camry vehicles equipped with the 4 cylinder engine, a power steering pressure hose in the engine compartment may be the incorrect length. If this condition exists a crimp on the power steering pressure hose may come in contact with the No. 7 Front Brake Tube ("brake tube").

Should this condition continue, a hole may wear in the brake tube and deplete the brake fluid in the vehicle. As a result, the brake pedal stroke will increase and lead to greater vehicle stopping distance.

Q2: Are there any warnings that this condition exists?

A2: No, there are no specific warnings that this condition exists.

Q3: What is Toyota going to do?

A3: Any Toyota dealer will inspect and if necessary adjust the space between the brake tube and the power steering pressure hose crimp. Based upon the inspection results, in a limited number of cases the dealership may need to replace the brake tube. The inspection/adjustment and, if necessary, the brake tube replacement, will be performed at **NO CHARGE** to the vehicle owner.

Q4: When will owners be notified?

A4: Toyota will notify owners by first class mail starting in mid-February, 2010.

Q5: Which and how many vehicles are involved?

A5: There are approximately 7,314 Camry vehicles involved in the U.S.

Q6: What is the production period of the affected vehicles?

A6: The affected Camry vehicles were produced from early February, 2009 to late March, 2009.

Q7: Are there any other Toyota or Lexus vehicles involved?

A7: No, this specific condition only affects certain early production 2010 model year Camry vehicles equipped with the 4 cylinder engine.

Q8: How long will the inspection take?

A8: The inspection will take approximately 45 minutes. However, depending upon the dealer's work schedule and the inspection results, it may be necessary to make the vehicle available for a longer period of time.

Q8a: What if replacement of the Brake Tube becomes necessary. How long will the repair take?

A8b: As these parts are not normally stocked by dealerships, it will take a few days for the dealer to order and receive them. The Toyota dealer will make every effort to assure each customer's utmost convenience during this waiting period.

Q9: What should an owner do if they experience the condition or have immediate concerns about the current safety of their vehicle?

A9: If an owner has immediate concerns they are requested to contact their local Toyota dealer for inspection and if applicable repair.

Owners may also contact the Toyota Customer Experience Center (1-800-331-4331) for additional assistance.