



Kawasaki Motors Corp., U.S.A.

March 2, 2009

Delia Lopez
Recall Management Division
NHTSA/Enforcement/ODI, NVS-215
1200 New Jersey Ave, SE., W46-425
Washington, DC 20590

Re: Service Bulletin/Manual Submission

Dear Ms Lopez:

In accordance with the requirements of 49 CFR Part 573.8 and Section 158 of the National Traffic and Motor Vehicle Safety Act, Kawasaki submits one copy of service bulletin/manual information that was distributed to Kawasaki dealers during the month of February.

<u>Bulletin Number</u>	<u>Dealer Distribution Date</u>	<u>Subject</u>	<u>Models Affected</u>
99931-1493-01	February 12, 2009	A & P manual	Ninja ZX-6R
Vol. 21, Issue 4	February 23, 2008	K-Tech News	All
MC 09-02	February 20, 2009	RECALL	2009 Ninja® ZX-10R
MC09-03	February 20, 2009	RECALL	2008/09 KLR 650
MC09-04	February 20, 2009	RECALL	2008/09 KLR 650
99924-1419-01	February 2, 2009	Service Manual	Ninja® 650R

Sincerely,

Kim La Bounty Harris
Public Affairs Analyst

Enclosures

P . O . Box 25252
Santa Ana, California
9 2 7 9 9 - 5 2 5 2

9 4 9 / 7 7 0 - 0 4 0 0
Fax 9 4 9 / 4 6 0 - 5 6 0 0
www.kawasaki.com

9950 Jeronimo Road
Irvine, California
9 2 6 1 8 - 2 0 8 4

MODEL: 2008 & 2009 KLR™ 650 (KL650E8F/L, KL650E9F/L)**TITLE: MAIN HARNESS INSPECTION**

RECALL

THIS BULLETIN IS OF THE HIGHEST PRIORITY AND MUST BE ACTED UPON IMMEDIATELY TO ENSURE CUSTOMER SAFETY.

Eligibility

Eligible Units

Model	Vehicle Identification Number Eligibility
KL650E8F/L KL650E9F/L	Check VIP in K-Dealer

Verify eligibility using VIP in K-Dealer before starting the repair.

IMPORTANT NOTE:

- o Check each unit for MC09-03 eligibility and complete campaign if necessary.

Please check VIP (Vehicle Information Portal) in K-Dealer for other possible repair campaigns for eligible units.

Subject

On eligible units, the main harness can chafe against the frame and cause the engine to stop running creating the potential for a crash resulting in injury or death.

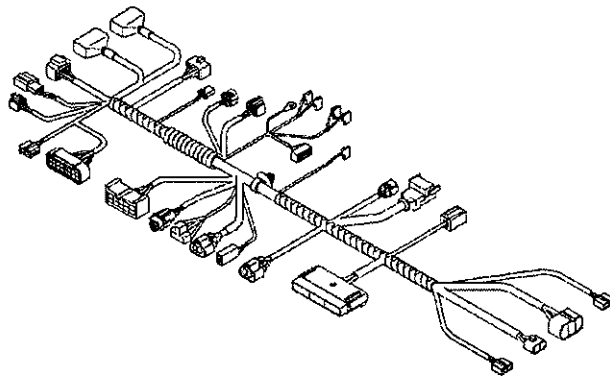

Kawasaki Action

Initiate Campaign:

Kawasaki has initiated a Recall campaign to repair all eligible units. The repair consists of reinforcing and rerouting the main harness and removing a clamp and a plate.

Notify Registered Owners:

Kawasaki is sending a Recall letter to all registered owners of eligible units. Refer to MC 09-03 for a copy of the common customer letter for this campaign.

Dealer Action

Repair Eligible Units:

Repair all eligible units including sold units in the field and unsold units in your dealership inventory prior to delivery to the retail purchaser. It is the obligation of authorized Kawasaki retail Dealers to repair eligible units in Dealer's possession prior to retail sale. Failure to comply with this obligation to repair all units eligible for Recall or FDM campaigns by the Dealer constitutes a breach of the Dealer Sales and Service Agreement. Refer to Service Policies bulletin SP 08-01. Refer to the Repair Procedure section of this bulletin for details.

IMPORTANT NOTE:

- o *It's the law! Under the U.S. National Highway Traffic Safety Administration (NHTSA), Federal Law 49 U.S.C. Section 30120(i) requires dealers to perform Recall repairs before delivering any vehicle affected by the Recall to a purchaser.*

Document Completed Repairs:

Federal law requires manufacturers to maintain accurate follow-up records on repairs performed

on eligible units. Dealers MUST submit a Warranty Claim for each repair. Refer to the Warranty Information section of this bulletin for details.

NOTE:

o *If you fail to submit a Warranty Claim for a new unit that is subsequently sold and registered, the new owner will receive the Recall letter requesting the return of the vehicle to you for repair.*

Submit Product Registration:

Submit the product registration to Kawasaki via K-Dealer immediately after retail sale of any eligible unit. Be sure to supply the correct customer name and mailing address. Kawasaki uses the product registration information for customer notification. Also, if you know that the customer has moved, please submit a Customer Update via K-Dealer.

Repair Procedure

Refer to the appropriate sections of the Service Manual for information and procedures related to parts removal and installation.

Service Manual

MODEL	PART NUMBER
KL650E8F/L KL650E9F/L	99924-1384-01~02

Inspect Main Harness

- Remove the side covers, seat, fuel tank and both upper cowlings.
- Check for damage to the main harness leads under the fuel tank mounting bracket.

NOTE:

o *If any copper wire has been exposed, remove and replace the main harness. If harness requires replacement, harness kit must be installed also. If chafing has occurred but has not exposed any copper wire, repair the chafing with harness black electrician's tape.*

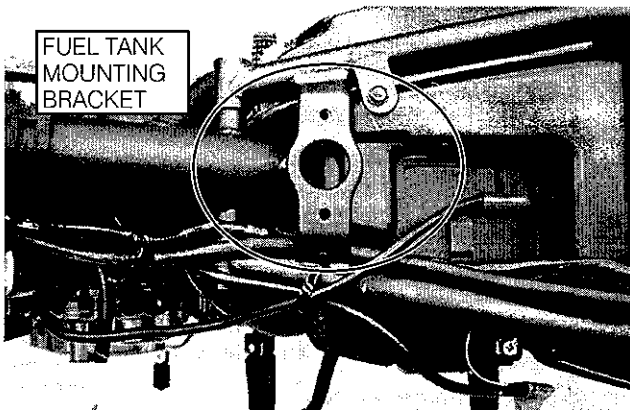

- Position the main harness under the reservoir overflow tube so it does not contact the fuel tank mounting bracket. Secure the main harness and overflow tube to the frame tube with the 200mm band included in the harness kit.

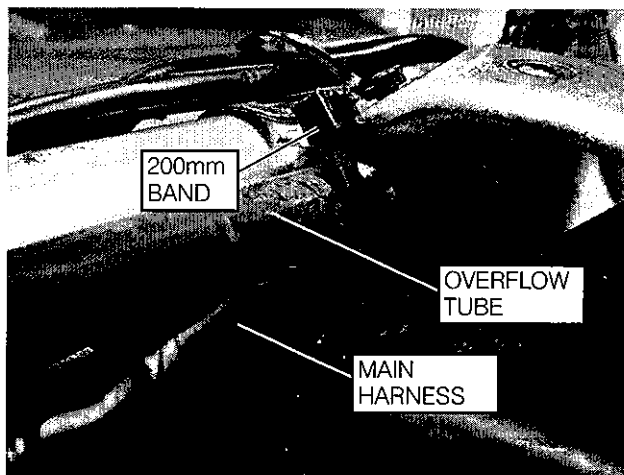

- Remove and discard the inside clamp on the horn bracket. Reinstall the bolt.



- Remove and discard the slotted steel plate on the backside of the head pipe.



- Pull out the three connectors (LH and RH switch housing connectors and ignition switch connector) from backside of the head pipe and disconnect the connectors.

NOTE:

- o Take care not to cut/damage the leads on the head pipe gussets, etc.

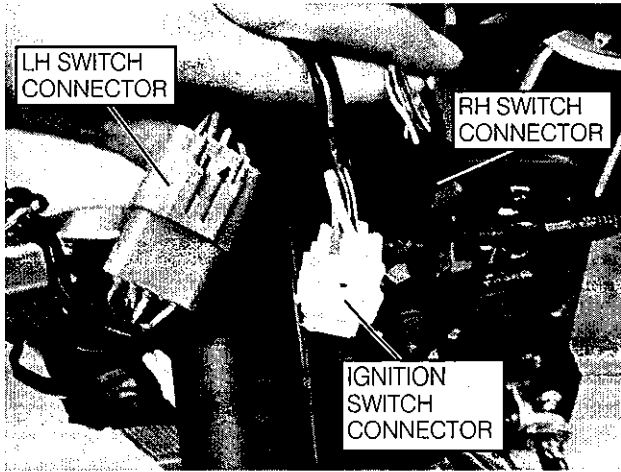

- Check the leads of the LH and RH switch housing and ignition switch for damage.

NOTE:

- o If any copper wire has been exposed, remove and replace the damaged parts. If chafing has occurred but has not exposed any copper wire, repair the chafing with black electrician's tape.

NOTE:

- o Do not wrap the harness tape tightly near the connector.

- Install the 50mm PVC tube on the upper forward LH switch housing lead and secure with black electrician's tape.
- Install a 120mm PVC tube on the lower aft LH switch housing lead and secure with black electrician's tape on both sides of the connector.

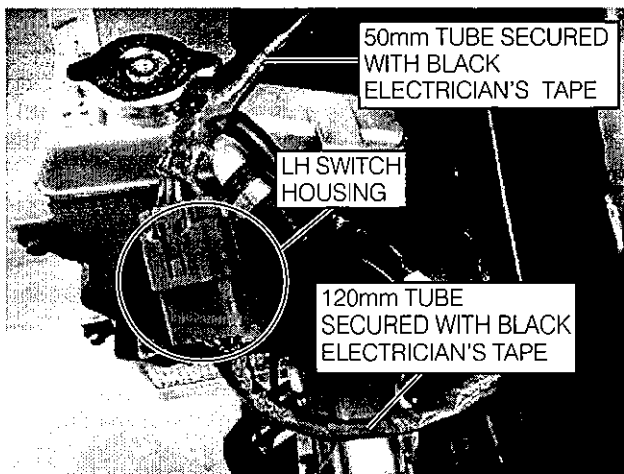

- Install a 120mm PVC tube on the RH switch housing lead and ignition switch lead of main harness and secure with black electrician's tape on the harness side of the connectors only.

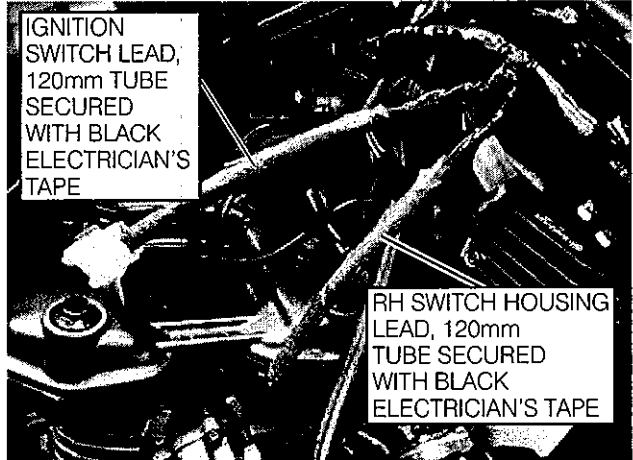

- Apply dielectric grease to the connector pins and connect the connectors and position the ignition switch connector and RH housing switch connector vertically into the backside of head pipe.
- Fasten the RH switch housing lead and ignition switch lead to the main harness with a 200mm band included in the harness kit.

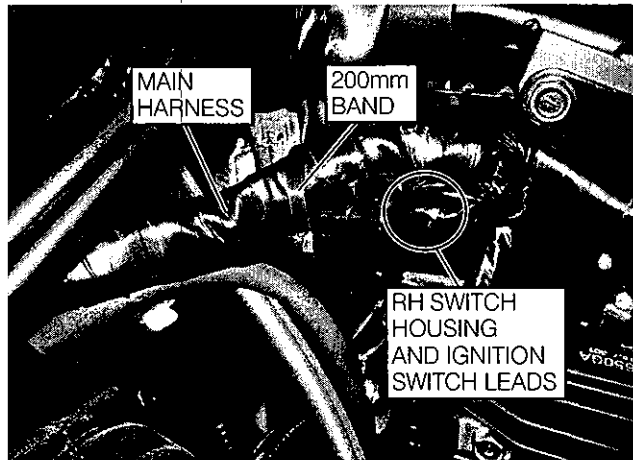

- Place the LH housing switch connectors inside the opening on the backside of head pipe.

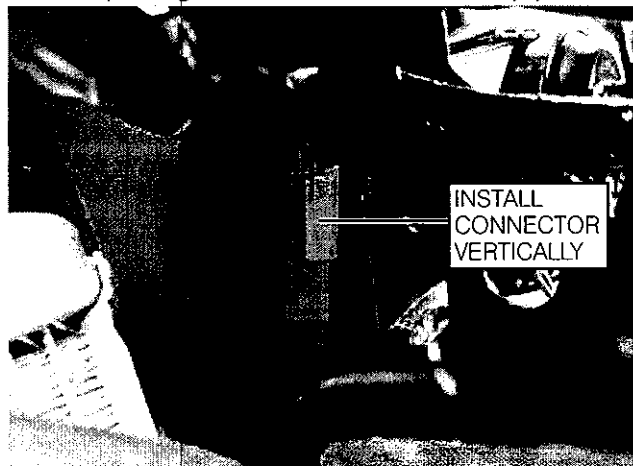

- Secure the connectors inside the opening on the backside of the head pipe with the 380mm band included in the harness kit.

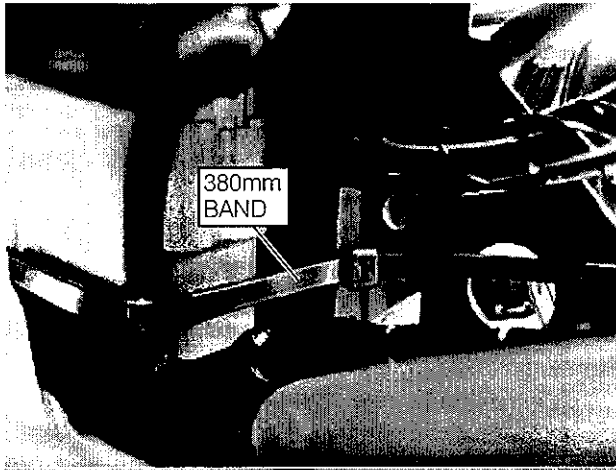

NOTE:

- o Route the band under the clutch cable and above the radiator mount.

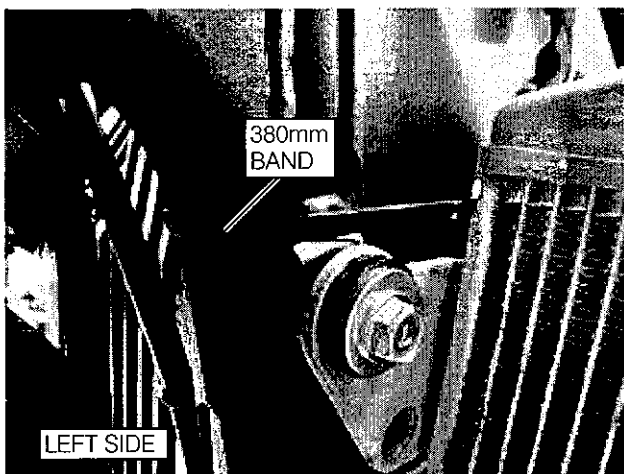
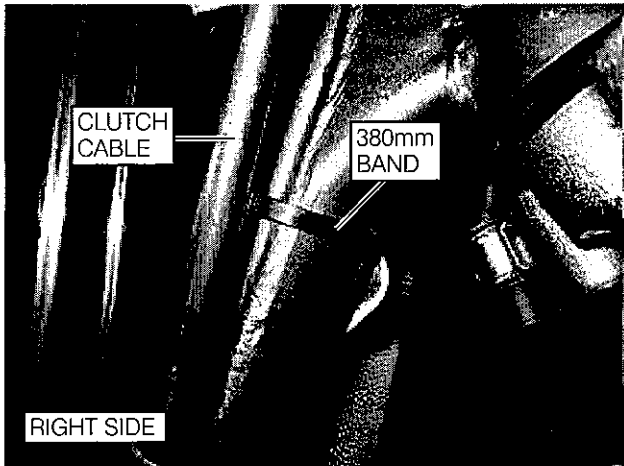

- Disassemble the starter relay cover and disconnect the side stand switch connector.
- Inspect side stand switch leads for damage.

NOTE:

- o If any copper wire has been exposed, remove and replace damaged parts. If chafing has occurred but has not exposed any copper wire, repair the chafing with black electrician's tape.
- Install the 70mm PVC tube on the side stand switch leads (on harness side).

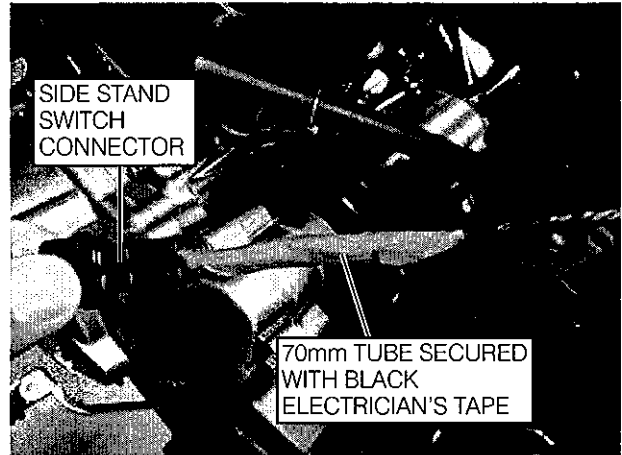

- Apply dielectric grease to the connector pins and connect the connector.
- Position the side stand leads behind the gusset as shown.

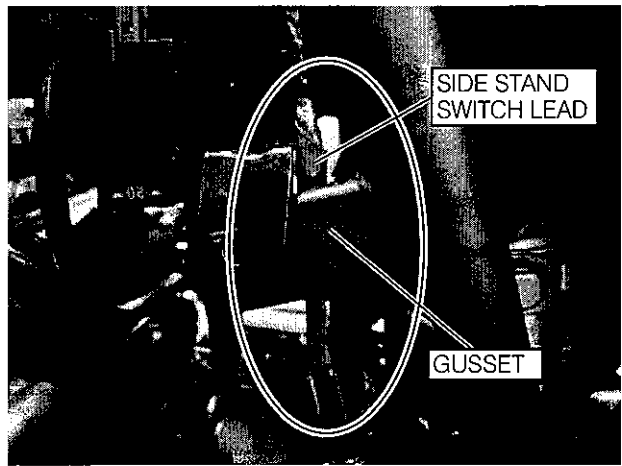

- Install starter relay cover.
- Install the side covers, seat, fuel tank and both upper cowlings.

Return the Main Harness:

If the main harness requires replacement, the chaffed main harness must be returned to Kawasaki along with a copy of the warranty claim to receive warranty reimbursement for this repair. Return the main harness to the following address:

Kawasaki Motors Corp., U.S.A.
 ATTN: Warranty Administration MC09-04
 9950 Jeronimo Road
 Irvine, CA 92618

Parts Information

A harness kit must be installed on all eligible units.

Parts required to complete the Recall must be ordered through Parts Order Services at (800) 608-8490. The proper VIN for each unit being repaired will be required for each part ordered.

Harness Kit, P/N 99999-0256

KIT CONTENTS	QTY
Band (L380)	1
Band (L200)	2
Tube (Ø10 X L120)	3
Tube (Ø10 X L50)	1
Tube (Ø6 X L70)	1

NOTE:

- o Use VIP in K-Dealer to identify affected units in your dealership inventory to order repair kits for unsold units

Warranty Information

This is a safety Recall campaign. Repair is authorized regardless of ownership or warranty status.

Repairs MUST BE PERFORMED IMMEDIATELY ON ALL ELIGIBLE UNITS in the field and during initial assembly and preparation.

Refer to the following service bulletins for important new features in K-Dealer making it quicker and easier to identify units eligible for repair campaigns (1) retailed by your dealership, and (2) those new units in your dealership requiring presale repair.

WTY 08-05 Repair Campaign Eligibility Check -- New Feature of K-Dealer

WTY 08-06 Repair Campaign System – Dealer Report Changes

See the Warranty Policies and Procedures Manual (claim type 3 information) for detailed instructions when submitting the Warranty Claim.

WARRANTY INFORMATION

	Kit Installation	Harness Replacement and Kit Installation
Job Code	22333	22334
Flat Rate Time	0.8 hr	1.4 hr
Failure Date	Same as Repair Date	Same as Repair Date
Claim Type	3	3
Problem Part Number	99999-0256	99999-0256
Description	Harness Kit	Harness Kit
Qty	1	1
Additional Parts	0	Harness, Main 26031-0604 Qty. 1

Repair Verification

Added PVC tubes will serve as repair verification.

NOTE:

- o Repair verification is an essential part of the repair procedure. Along with the physical repair verification, check VIP (Vehicle Information Portal) in K-Dealer for other possible repair campaigns for eligible units.

