



MOTOR COACH  
INDUSTRIES

**THIS LETTER IS A FOLLOW-UP  
TO AN EARLIER NOTICE.  
MCI URGES YOU TO MAKE  
ARRANGEMENTS TO REPAIR  
YOUR AFFECTED VEHICLE(S)  
AS SOON AS POSSIBLE.**

December 14, 2011

«Customer\_Name»

ATTENTION: TECH SERVICE DEPT/MAINT

«Address»

«Address\_2»

«City», «State» «Zip»

«ctry»

**SUBJECT: SAFETY RECALL OF WHEELCHAIR LIFT UPPER DOOR WARNING  
AND LATCH**

Ref.: **NHTSA # 09V-345  
TRANSPORT CANADA # 09-254  
MCI Service Bulletin 325B**

Attention Owner:

This notice is sent to you in accordance with the National Traffic and Motor Vehicle Safety Act and the Canadian Motor Vehicle Safety Act.

Motor Coach Industries, Inc. (“MCI”) has decided that a defect which relates to motor vehicle safety exists in MCI’s 2001-2004 Model G4500 model coaches equipped with wheelchair lifts. If the upper wheelchair door opens due to a malfunction of both the door’s latches, there is a telltale light in the driver’s dash that illuminates to alert the driver that the upper wheelchair door is not fully latched and closed. MCI has become aware that the driver may not notice the illuminated telltale light indicating that the wheelchair door is not fully latched and closed, which in turn could result in the wheelchair door sliding open without further warning and expose passengers to the risk of falling from the coach while the vehicle is in motion. Please see the enclosed MCI Service Bulletin 325B for further information.

The vehicles that are subject to this notice are the following 2001-2004 Model G4500 model coaches equipped with wheelchair lifts:

80036 – 80045	80056 – 80171	80182 – 80194	80198 – 80199	80201 – 80202
80206	80249 – 80253	80266 – 80288	80307 – 80367	80388 – 80472
80497 – 80510	62536 – 62555			

1700 EAST GOLF ROAD, SUITE 300  
SCHAUMBURG, ILLINOIS 60173  
847-285-2000 PHONE  
866-624-2622 TOLL FREE  
WWW.MCICOACH.COM

MCI is conducting a recall to add an audible alarm in the driver's area as an additional alert to the driver that the wheelchair door is not fully latched and closed. MCI also plans to reinforce the upper door latch to improve latching system durability. In conjunction with these changes, MCI will also add a manual emergency release of the wheelchair door to improve accessibility to the operator to release the door latches. Please see the enclosed MCI Service Bulletin 325B, which describes in further detail the addition of the audible alarm, wheelchair door latch reinforcement, and enhanced emergency latch release. These additions and reinforcements will be done at no cost to you.

MCI records indicate that you are the owner or operator of the following vehicle(s) included in this recall:

«Unit\_Numbers»

MCI strongly urges you to have the recall work performed on your vehicle(s) as quickly as possible.

You may contact the MCI Customer Service Line at 1-800-241-2947 to make arrangements to have your vehicle(s) inspected and repaired as necessary at an authorized MCI service center. Submittal of MCI Warranty Claim Forms may be completed on MCI's website at <http://fleetsupportiw.mcicoach.com/iwarranty/signon> (click on Customer Care System), or a photocopy of the Warranty Claim Form found in the Warranty Manual can be mailed / faxed to the MCI Warranty Department. Please refer to MCI Service Bulletin 325B and your OWNER LIMITED WARRANTY MANUAL for more detailed information.

If you have any questions about this recall campaign, you may contact the MCI Customer Service Line at 1-800-241-2947.

After contacting MCI Customer Service, if you are still unable to have the safety defect remedied without charge and within a reasonable time, you may submit a complaint:

For the U.S.:

The Administrator  
National Highway Traffic Safety Administration  
1200 New Jersey Avenue, SE.,  
Washington, DC 20590;  
or call the toll-free Vehicle Safety Hotline at 1-888-327-4236; (TTY: 1-800-424-9153); or go to <http://www.safercar.gov>.

For Canada:  
Road Safety and Motor Vehicle  
Regulation Directorate

1700 EAST GOLF ROAD, SUITE 300  
SCHAUMBURG, ILLINOIS 60173  
847-285-2000 PHONE  
866-624-2622 TOLL FREE  
WWW.MCICOACH.COM

Transport Canada  
Tower C, Place de Ville  
330 Sparks Street  
Ottawa, Ontario  
K1A 0N5  
or call the Transport Canada's Information Centre at 1-800-333-0371.

If you are the lessor of the vehicle(s) identified above, Federal law requires that you forward this notice by first class mail to the most recent lessee(s) known to you, within ten days of your receipt of this notice.

If you have sold or otherwise transferred the vehicle(s) identified above, please contact the MCI Customer Service Line at 1-800-241-2947 with all of the information you have regarding the current owner/operator of the vehicle(s), so that we can ensure that the vehicles are inspected and repaired as necessary.

If you had your vehicle repaired or inspected for this condition prior to receipt of this notice and incurred any costs, you may be eligible for reimbursement. Please contact the MCI Customer Service Line at 1-800-241-2947 for further information in that regard.

We regret the inconvenience this may cause you, but urge you to have your vehicle(s) inspected and repaired as necessary as soon as possible for your added safety and satisfaction.

Sincerely,

*Motor Coach Industries*  
Warranty Department

Enclosure: MCI Service Bulletin 325B



# Service Bulletin No. 325B

<b>MODEL</b> G4500 Series Coaches equipped w/ wheelchair	<b>TYPE</b> Field Change Program	<b>SECTION/GROUP</b> 3-Body	<b>DATE</b> Sept. 3, 2009
<b>SUBJECT</b> WHEELCHAIR LIFT ( WCL ) INTERLOCK DOOR RETROFIT			
<b>CONDITIONS</b>			

**THIS BULLETIN SUPERSEDES SERVICE BULLETIN 325 IN ITS ENTIRETY.**

Ref. NHTSA Recall No.: 09V-345

Ref. Transport Canada Recall No.: 09-254

### Customer Complaint:

If the sliding wheelchair door becomes unlatched, the visual warning indicator in the driver's area may not be noticed by the operator in the absence of an audible warning as well. Additionally, the manual emergency sliding door release is difficult for the operator to locate should air pressure not be available to unlatch the door.

### Cause:

The present visual indicator in the driver's area may not be sufficient to be noticed by the operator in the event that the wheelchair sliding door is not properly latched. An audible warning in addition to the visual warning is preferred. Also, the current upper door latch needs to be reinforced to improve latching durability.

### Corrective Action:

MCI strongly encourages operators to install the additional audible warning device that works in conjunction with the current visual warning lamp to improve the indication to the operator that the wheelchair sliding door is not properly latched. The wheelchair door interlock kit also adds a reinforcement to the upper door latch to improve latching system durability. The rework listed below also adds an emergency release accessible by opening the wheelchair lift compartment door to improve accessibility for the operator.

Accordingly, MCI advises that owners of G4500 model coaches equipped with wheelchair lifts between the range of, and including, unit numbers 80036 to 80045, 80056 to 80171, 80182 to 80194, 80198, 80199, 80201, 80202, 80206, 80249 to 80253, 80266 to 80288, 80307 to 80367, 80388 to 80472, 80497 to 80510, 62536 to 62555 to implement the specified steps in this procedure.

### Parts

<u>Qty.</u>	<u>New P/N</u>	<u>Description</u>
1	26-07-0026	Kit, Beeper, Underdash, Multiplex Coaches <i>Kit Contents Are:</i>
1	07-08-2796	Bracket, Beeper
1	07-08-6252	Beeper
1	07-12-2939	Harness Extension, Beeper
1	07-12-2940	Harness Power, Beeper
1	07-14-4018	Schematic, Multiplex
2	19-1-758	Screw, Tapping
5	19-11-1465	Heat Shrink
5	19-11-1466	Solder Splice
1	19-11-569	Tyrap
3	19-11-969	Wire, Black, 18 AWG, 3 ft.

**Parts**

<b>Qty.</b>	<b>New P/N</b>	<b>Description</b>
1	26-07-0025	Kit, Beeper, Underdash, Non-Multiplex Coaches <i>Kit Contents Are:</i>
1	07-08-2796	Bracket, Beeper
1	07-08-6252	Beeper
1	07-12-2945	Harness Extension, Beeper
1	07-12-2940	Harness Power, Beeper
1	07-14-4019	Schematic, Multiplex
2	19-1-758	Screw, Tapping
5	19-11-1465	Heat Shrink
5	19-11-1466	Solder Splice
1	19-11-569	Tyrap

**Parts**

<b>Qty.</b>	<b>New P/N</b>	<b>Description</b>
1	26-03-0026	Kit, WCL Interlock Door <i>Kit Contents Are:</i>
1	03-31-1100	Clip, Rod
1	03-31-3255	Bracket, Lever
1	03-31-3257	Lever Assy, Latch
1	03-31-3258	Rod Latch Release
1	03-31-3259	Plate
1	03-31-3260	Gusset
1	03-31-3261	Gusset
1	03-31-3265	Bracket Assy, Solenoid
1	03-31-3272	Gusset
1	03-31-3281	Bracket, Actuator
1	03-32-1490	Handle, Latch Release, Wac
1	07-12-3066	Harness, Solenoid Adapter
1	07-14-4343	Schematic, Wheelchair
1	07-14-4344	Schematic, Wheelchair, Mux
1	19-01-1543	Capscrew, 3/8–16 x 3/4
1	19-01-1957	Screw, #10–24 x 3/4 Pan Hd, Cross Recess
1	19-03-0535	Locknut, Flanged, 3/8–16 Unc
1	19-09-0087	Pushnut, 0.156 Dia
2	19-1-16	Capscrew, 5.16–18 x 3/4
3	19-1-696	Screw, Tapping, 10–32 Unf x 1/2
2	19-11-2048	Seal Wp, Cable, 10 Awg Grn
20	19-11-569	Tyrap
2	19-11-760	Pin, 18 Ga
1	19-11-845	Receptacle, 2 pin
1	19-12-20	Grommet, 5/8, 1/16 Groove, Rubber
2	19-12-4	Grommet, 3/8, 1/16 Groove, Rubber
4	19-13-137	Rivet, 0.187
2	19-2-187	Washer, Fender 5/16 ID, 3/4 OD
2	19-3-183	Locknut, 5/16–18
2	21-7408-155	Tube, Airline, 1/4" OD, Black, 10ft.
1	3J-21-35	Rubber Cover



## **NON-MULTIPLEX WELDING CAUTION**

***The following information must be read before beginning any welding. The prohibitions and requirements must be followed to prevent personal injury and damage to electrical components. Also follow any welding instructions and cautions associated with the specific component being repaired.***

***Welding may only be done by an experienced and qualified person. All welding must conform to AWS D1.1 Structural Welding Code - Steel. All applicable instructions and prohibitions must be followed.***

***Position ground contacts and barriers as close as possible to the weld area to protect components (wiring, brake lines, bearings, hydraulic lines, etc.) from heat, contact by weld splatter and arcing.***

### **PRE-WELDING DISCONNECTION ON G4500 NON-MULTIPLEX COACHES ( UNIT NUMBERS 80026 – 80412 AND 80418 – 80451 )**

1. **Switch the main battery disconnect OFF.**
2. In the **BATTERY COMPARTMENT**, in the order given:
  - a. Disconnect the ground.
  - b. Disconnect the 12-volt cable at the battery and tape terminals.
  - c. Disconnect the 24-volt cable at the battery and tape terminals.
3. In the **JUNCTION BOX COMPARTMENT**, in the order given:
  - a. Disconnect the transmission ECU ( 3 connectors ).
  - b. Disconnect the ABS ECU ( 5 connectors ).
  - c. Disconnect the 2 connectors from the HVAC controller.
4. In the **ENGINE COMPARTMENT**, in the order given:
  - a. Disconnect all connectors on the engine ECM ( 5 connectors ).
  - b. Disconnect the transmission main plug ( 1 connector ).
5. In the **DRIVERS CONSOLE**:
  - a. Disconnect the translator module ( P-15 ).
6. In the **INSTRUMENT PANEL**:
  - a. Disconnect the black connector ( P-19 ).
7. On the **STEERING COLUMN**:
  - a. Disconnect the 3 connectors ( P-AA, P-BB and P-183 ).
8. In the **WIPER CONTROL MODULE**:
  - a. Disconnect the 2 connectors ( P-10 and P-11 ).
9. In the **CRUISE CONTROL MODULE**:
  - a. Disconnect the 3 connectors ( J-2, J-3 and P-31 ).
10. In the **LEFT HAND SWITCH PANEL**:
  - a. Disconnect the HVAC driver's control module.
11. In the **PROHEAT CONTROL MODULE**:
  - a. Disconnect the Proheat power cable at the Proheat control module.

*Pre-welding Disconnection Procedure complete.*



## **MULTIPLEX WELDING CAUTION**

***The following information must be read before beginning any welding. The prohibitions and requirements must be followed to prevent personal injury and damage to electrical components. Also follow any welding instructions and cautions associated with the specific component being repaired.***

***Welding may only be done by an experienced and qualified person. All welding must conform to AWS D1.1 Structural Welding Code - Steel. All applicable instructions and prohibitions must be followed.***

***Position ground contacts and barriers as close as possible to the weld area to protect components (wiring, brake lines, bearings, hydraulic lines, etc.) from heat, contact by weld splatter and arcing.***

### **PRE-WELDING DISCONNECTION ON G4500 MULTIPLEXED COACHES ( UNIT NUMBERS 80413 – 80417 AND 80452 – 80518 )**

1. **Switch the main battery disconnect OFF.**
2. In the **BATTERY COMPARTMENT**, in the order given:
  - a. Disconnect the ground.
  - b. Disconnect the 12–volt cable at the battery and tape terminals.
  - c. Disconnect the 24–volt cable at the battery and tape terminals.
3. In the **JUNCTION BOX COMPARTMENT**, in the order given:
  - a. Disconnect the transmission ECU ( 3 connectors ).
  - b. Disconnect the ABS ECU ( 5 connectors ).
  - c. Disconnect the 2 connectors from the HVAC controller.
4. In the **ENGINE COMPARTMENT**, in the order given:
  - a. Disconnect all connectors on the engine ECM ( 5 connectors ).
  - b. Disconnect the transmission main plug ( 1 connector ).
5. In the **DRIVERS CONSOLE**:
  - a. Disconnect the translator module ( P–15 ).
6. In the **INSTRUMENT PANEL**:
  - a. Disconnect the red connector ( P–19 ).
7. On the **STEERING COLUMN**:
  - a. Disconnect the 3 connectors ( P–AA, P–BB and P–183 ).
8. In the **WIPER CONTROL MODULE**:
  - a. Disconnect the 2 connectors ( P–10 and P–11 ).
9. In the **CRUISE CONTROL MODULE**:
  - a. Disconnect the 3 connectors ( J–2, J–3 and P–31 ).
10. In the **LEFT HAND SWITCH PANEL**:
  - a. Disconnect the HVAC driver’s control module.
11. At the **MBC MODULE BLACK**:
  - a. Disconnect connector.
12. In the **PROHEAT CONTROL MODULE**:
  - a. Disconnect the Proheat power cable at the Proheat control module.

*Pre–welding Disconnection Procedure complete.*

## **POST-WELDING RE-CONNECTION ON G4500 MODEL COACH**

1. When welding is complete, re-connect all items in the **exact reverse order** from disconnection. Re-connection order is critical to safety.



### **WARNING**

***To prevent personal injury, exercise extreme caution at power-up.***

2. Verify that all connections are complete and secure.
3. Warn all personnel in the area that the power is going to be switched on.
4. Ensure that all personnel are clear of the immediate area.
5. Switch the main battery disconnect ON.



### **NOTE**

***AFTER POST-WELDING CONNECTION PROCEDURE IS COMPLETE, TEST ALL COACH SYSTEMS TO ENSURE PROPER FUNCTIONING OF EACH COMPONENT.***

*Post welding Re-connection Procedure complete.*

## Service Procedure:

### General notes

Read this entire procedure before beginning work.

### Use Safe Shop Practices At All Times.

1. Turn the main battery disconnect switch to the OFF position. Chock both sides of the tires.
2. Fold and position passenger sliding seats to provide access to the wheelchair door ( refer to Figure 1 ).



**Figure 1.**

3. To access the installation area, remove the front cover –post, rear cover –post and service module cover assy ( refer to Figure 2 ). Place aside to be re-installed at a later step in this procedure.

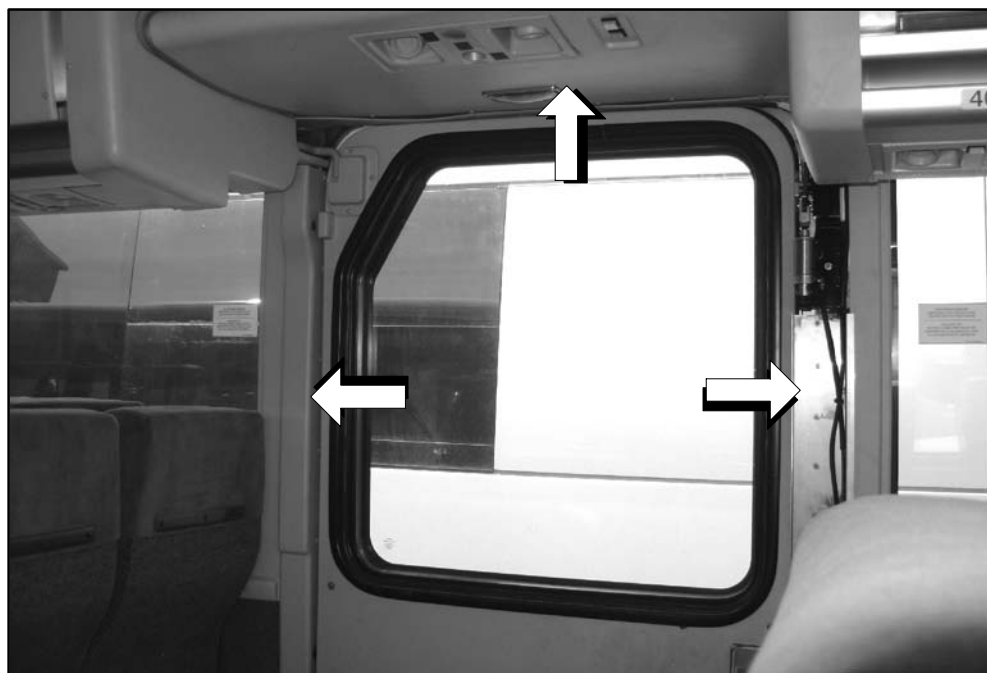

**Figure 2.**

4. Locate and open the lift access compartment door, directly below the sliding wheelchair access door.
5. Using an industrial heat gun and steel brush, clean to remove all the dirt and loose paint or rust from the installation area ( refer to Figures 3 and 4 ).
6. Tack weld the gusset ( p/n 03-31-3272 ) into position, according to Figure 3.
7. Weld the gusset, using the weld sizes and locations in Figure 3.

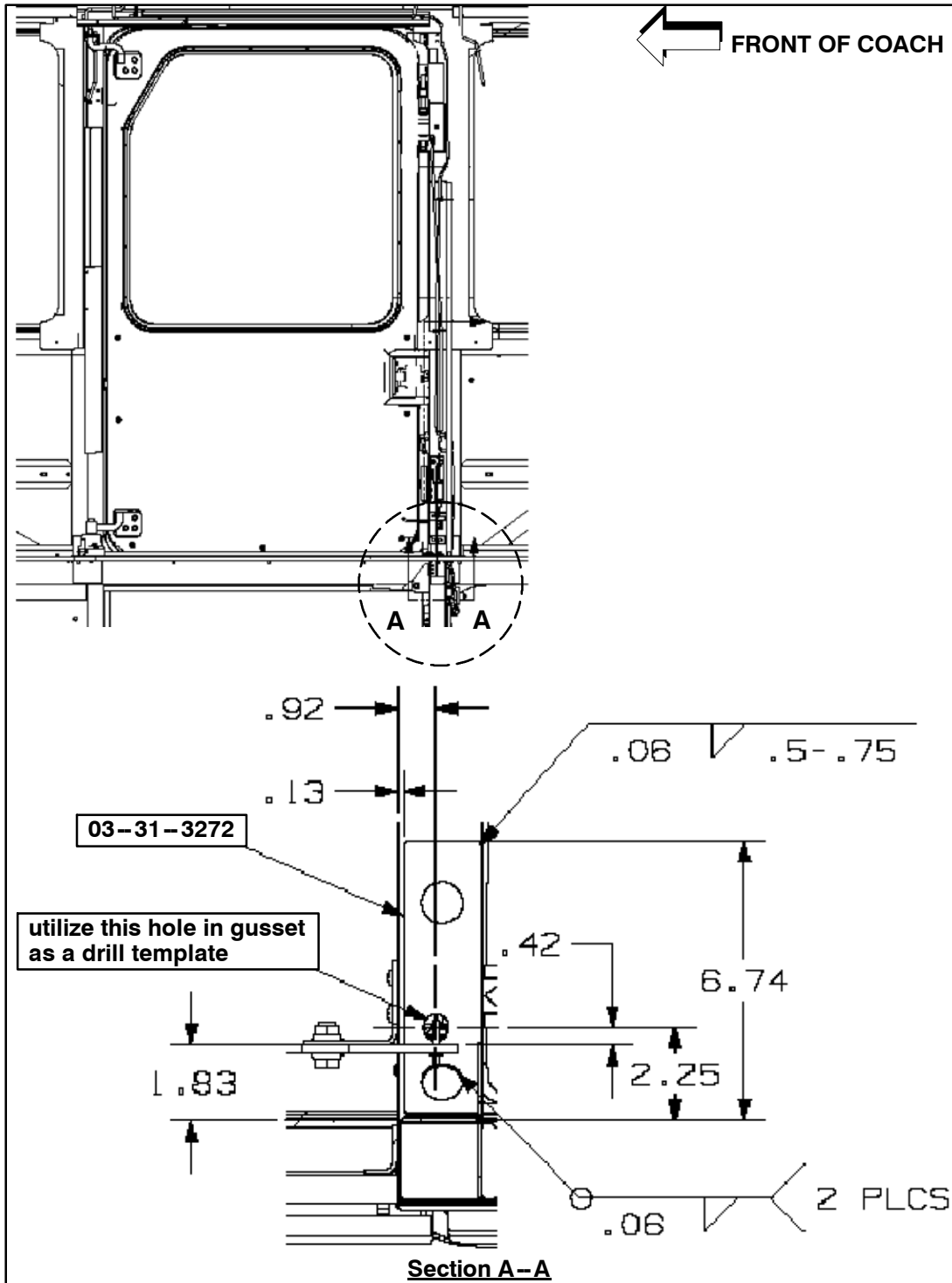

Figure 3. Gusset installation corner ( top, rearward corner of the lift access compartment ).

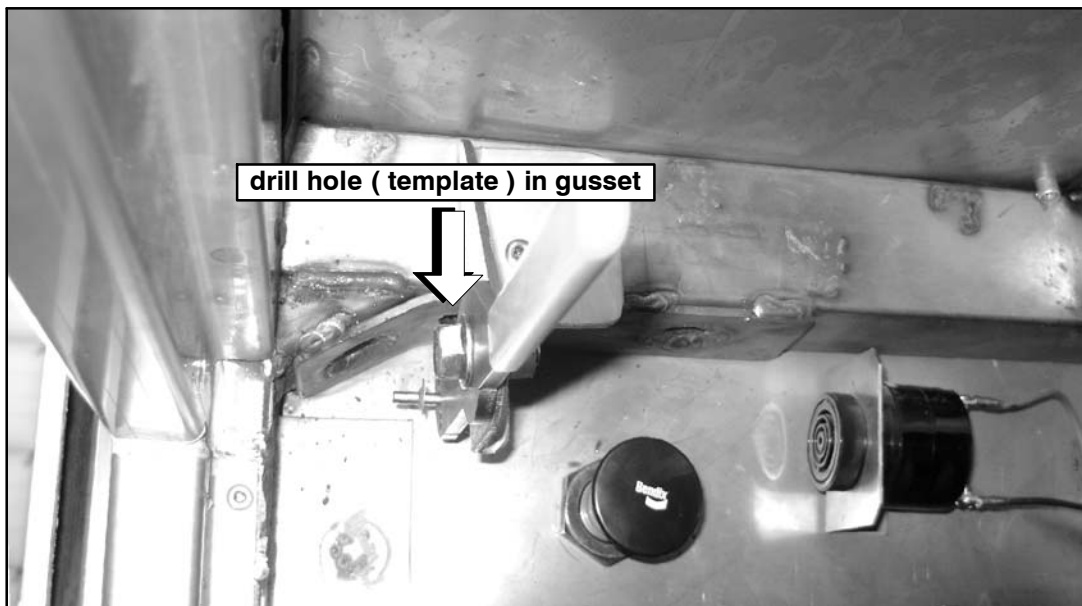

Figure 4.

**! WARNING**

Allow enough time for weld to cool down to avoid personal injury when drilling hole.

- 8. Using a 0.63 inch drill bit and the hole in the gusset as a template, drill a hole up through the tube frame and floor per the dimensions shown in Figure 5 into the coach cabin ( refer to Figures 3 and 4 for hole location on gusset ).

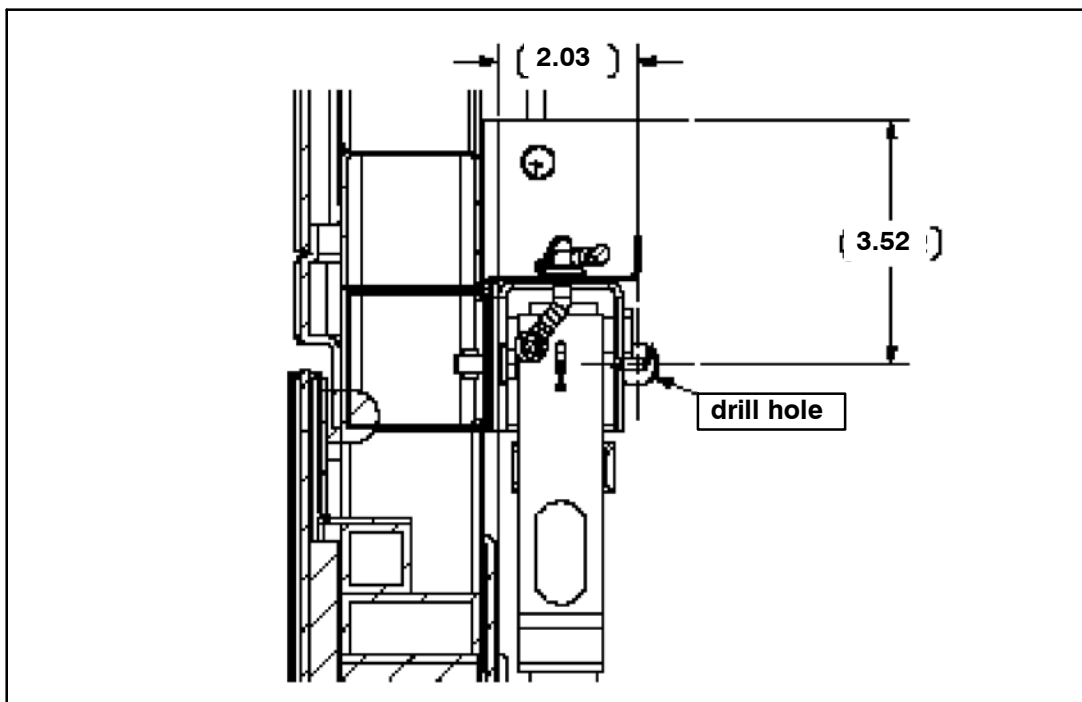
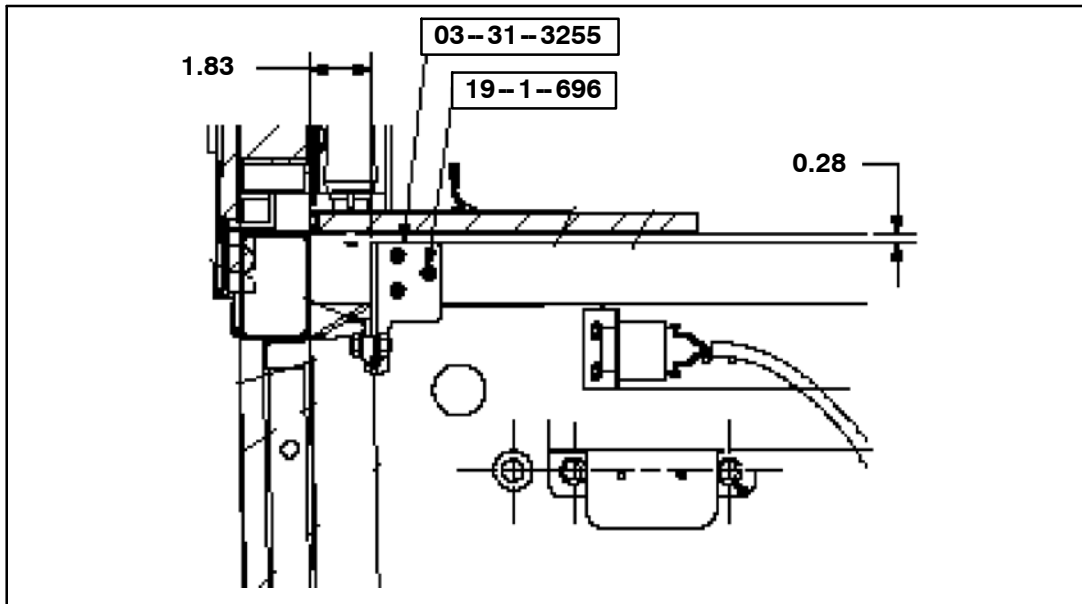

Figure 5.

9. Position bracket, lever, p/n 03-31-3255, as shown in Figures 6 and 7.



**Figure 6. installation dimension.**



**Figure 7. Reference photo.**

10. Secure bracket, lever in place. Using a 0.149 drill bit, drill 3 holes using the bracket, lever as a template. Using screw, p/n 19-1-696, mount the bracket, lever to the compartment wall.
11. Using the capscrew, p/n 19-01-1543, and locknut, p/n 19-03-0535, install the latch release handle, p/n 03-32-1490 to the bracket, lever. Slide the rubber cover, p/n 3J-21-35, over the latch release handle (refer to Figure 7).

12. Remove and retain the four (4) mounting screws from the existing lever assy–latch. Discard existing lever assy–latch. Using the four (4) mounting screws, install the new lever assy–latch, p/n 03–31–3257 (refer to Figure 8). Tighten screws to secure.

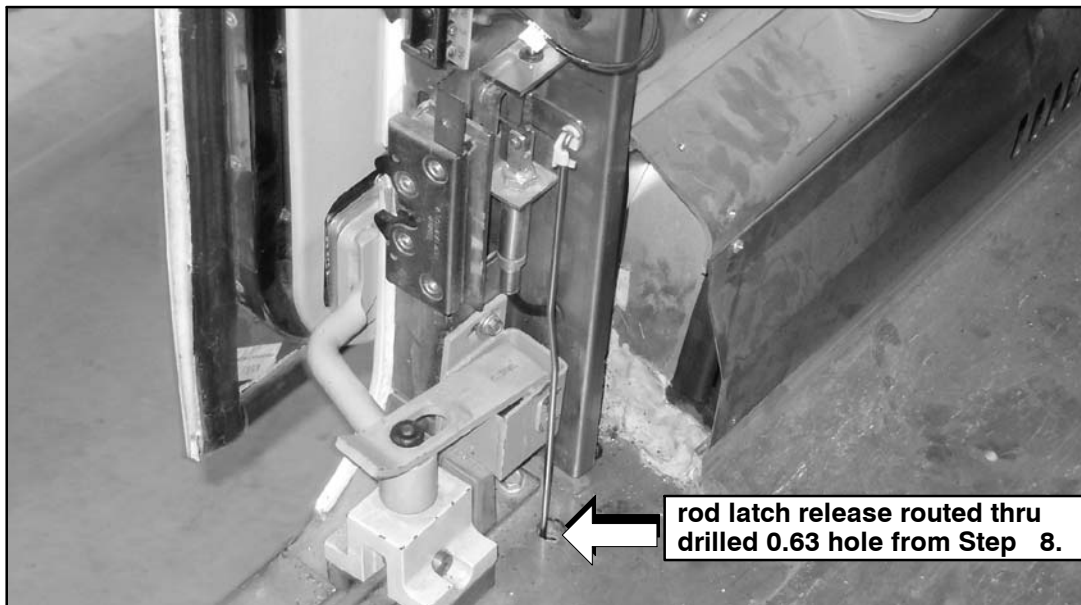

**Figure 8.**

13. Align and route the rod latch release, p/n 03–31–3258, thru the drilled hole (refer to Figure 8). Using the clip rod, p/n 03–31–1100, install the rod latch release as shown in Figure 9 (refer to Figures 9 and 10).

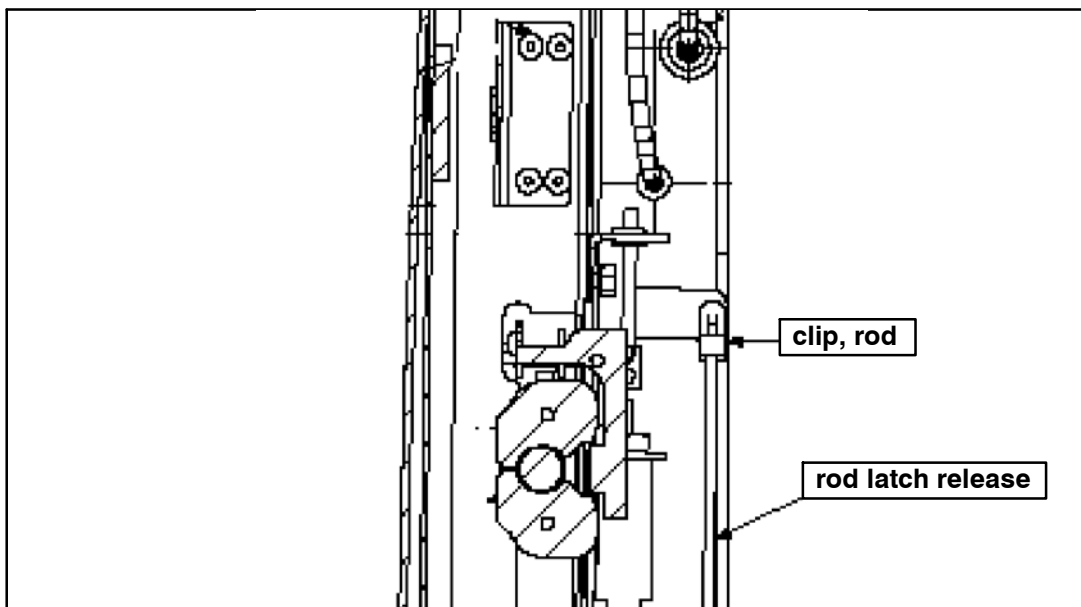

**Figure 9.**



**Figure 10.**

14. Exit coach cabin and proceed to the lift access compartment. Using pushnut, p/n 19-09-0087, attach rod latch release to the the latch release handle ( refer to Figure 11 ).



**Figure 11.**

15. Position the solenoid bracket assy, p/n 03-31-3265, on the side panel of the lift access compartment as per dimensions shown in Figure 12 ( refer to Figures 12 and 13 ).
16. Using a 0.34 inch drill bit and the two (2) holes in the solenoid bracket assy as a template, drill two (2) mounting holes. Using capscrew, p/n 19-1-16, fender washer, p/n19-2-187 and locknut, p/n 19-3-183, securely mount the solenoid bracket assy to compartment wall.
17. Using a 0.87 inch drill bit, drill a hole as per dimensions shown in Figure 12. Install grommet, p/n 19-12-20, in drilled hole ( refer to Figures 12 and 13 ).

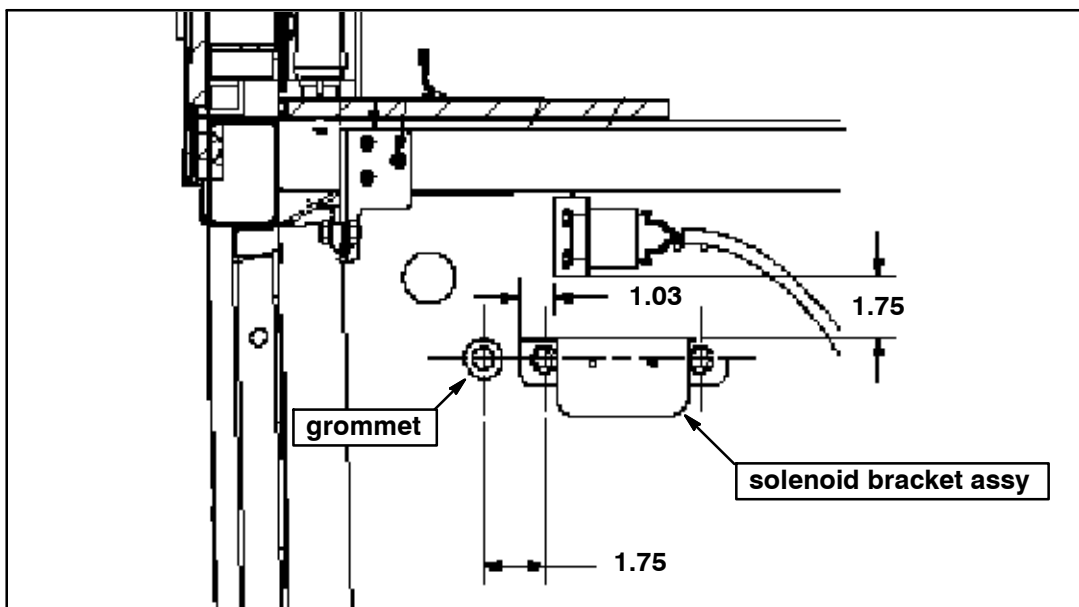

Figure 12.

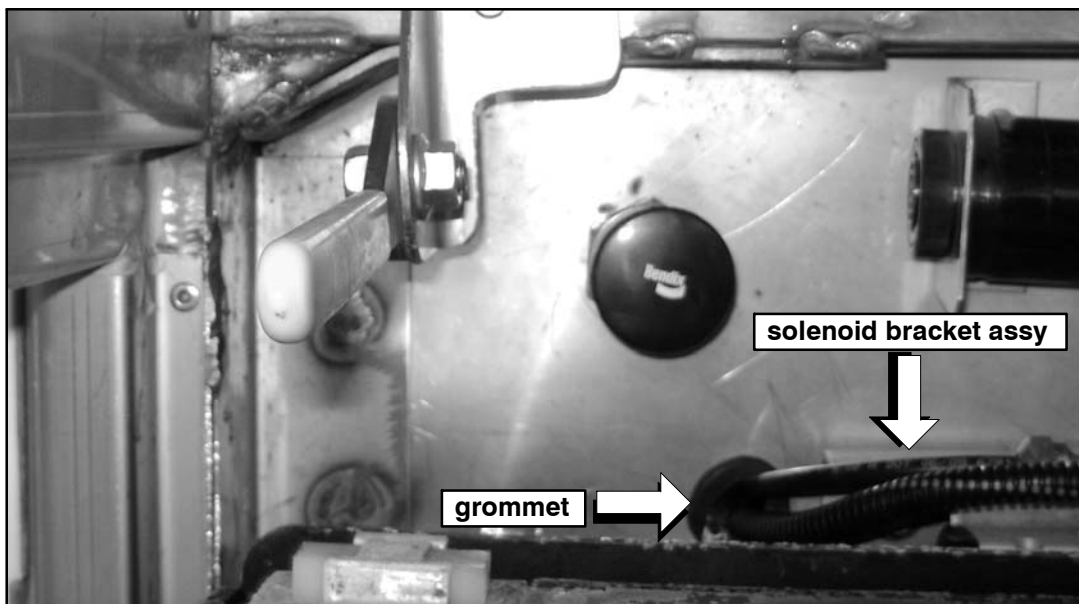

Figure 13.

18. Locate and remove the existing valve assy–door ( refer to Figure 14 ).

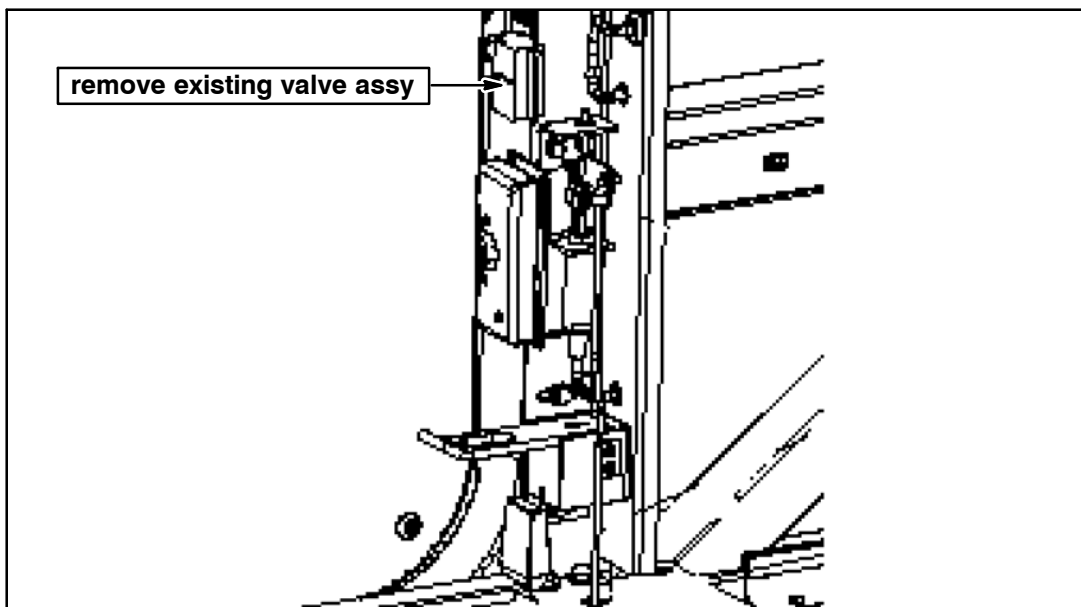

Figure 14.

19. Using the two dimensions ( 1.40 and 0.41 ) shown in Figure 15, position the bracket, actuator, p/n 03–31–3281, and secure in place. Using a 0.20 drill bit and the four (4) holes in the bracket, actuator as a drill template, drill four mounting holes into the frame. Using rivets, p/n 19–13–137, mount the bracket, actuator to the frame ( refer to Figures 15 and 16 ).

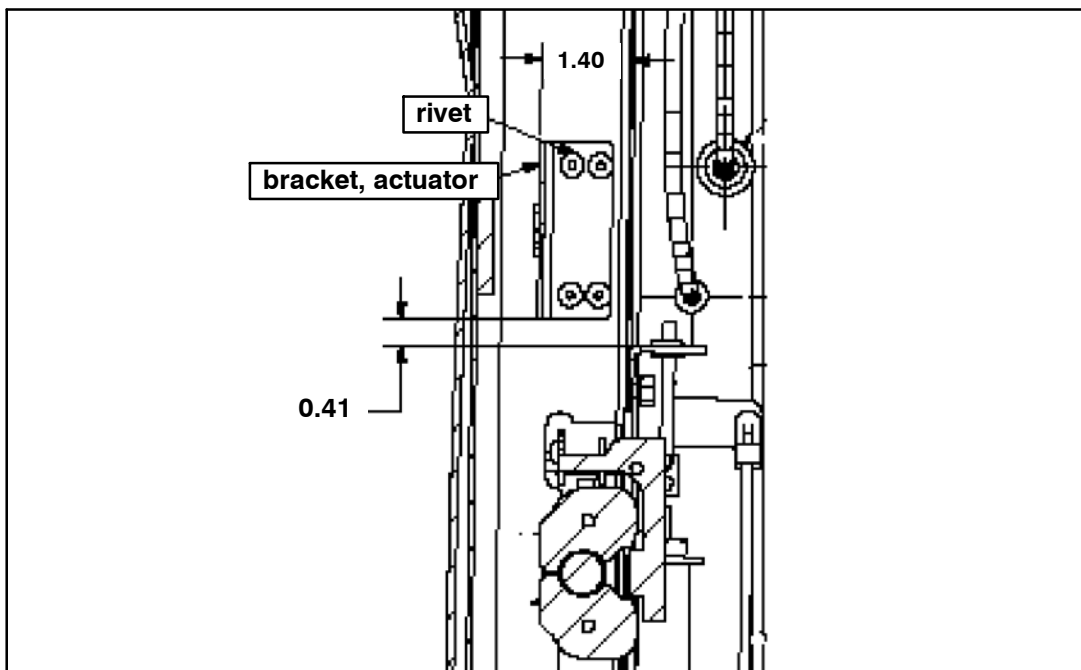
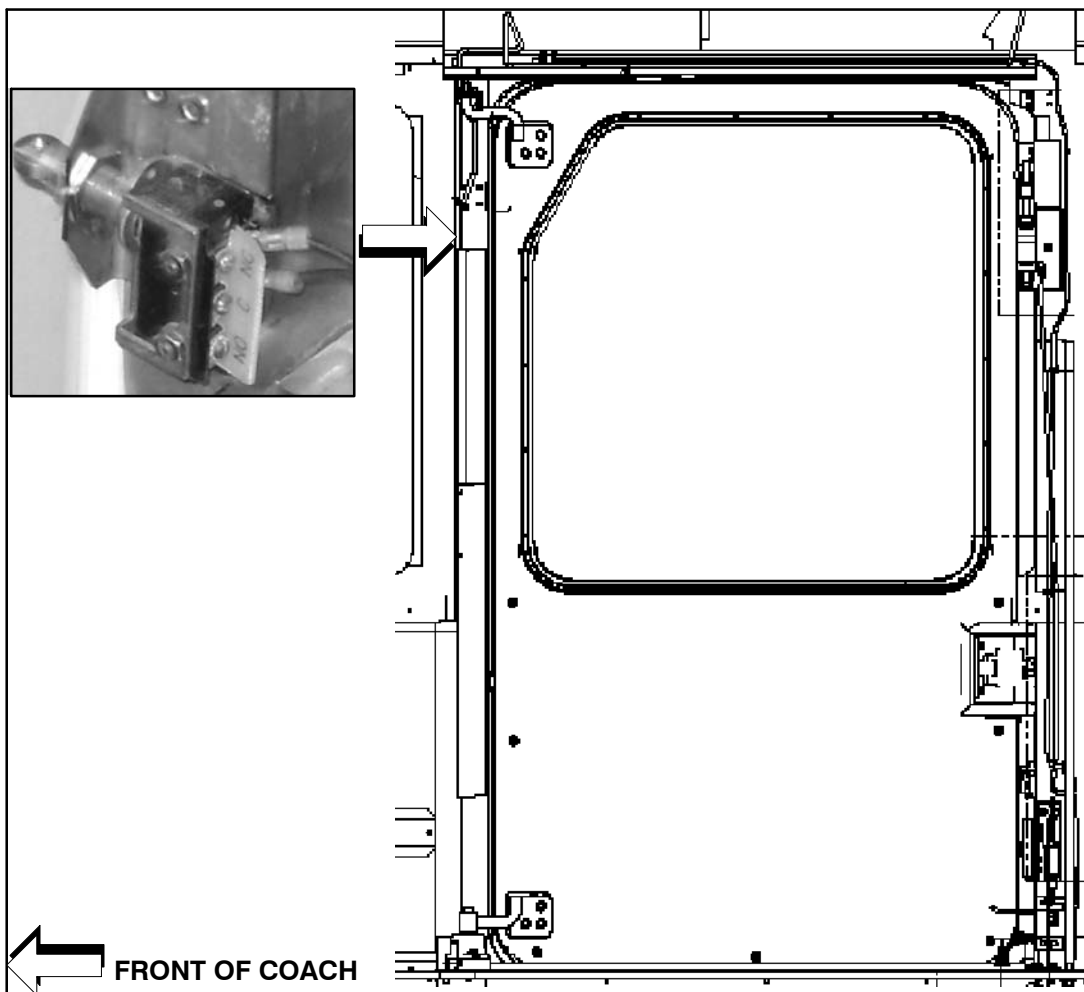

Figure 15.



**Figure 16.**

- 20. Locate the switch and actuator from upper, forward corner of the door ( refer to Figure 17 ). Disconnect the harness. Carefully remove and retain the existing switch and actuator.



**Figure 17.**

21. Install the switch and actuator, removed in Step 20. , to the bracket, actuator, p/n 03-31-3281, installed in Step 19. ( refer to Figure 18 ). Connect the harness.



**Figure 18.**

22. Using the two dimensions ( 1.99 and 0.53 ) shown in Figure 19, and a 0.62 drill bit, drill a hole into the frame. Install grommet, p/n 19-12-4, in hole.

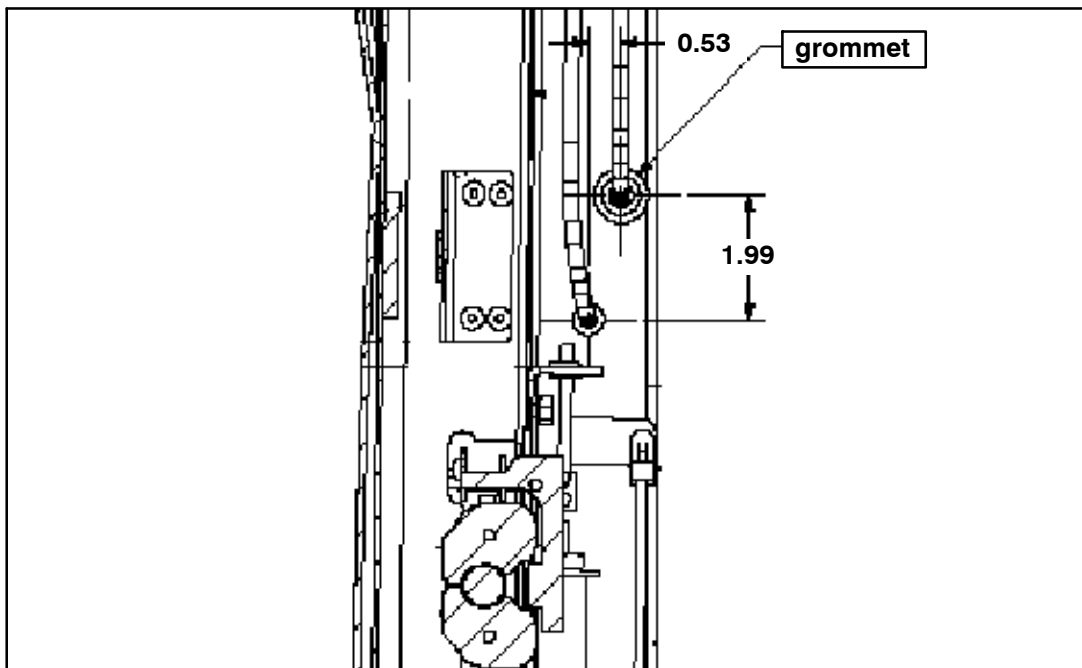

**Figure 19.**

23. Using a 0.62 inch drill bit, drill a hole as per dimensions shown in Figure 20. Install grommet, p/n 19-12-4, in drilled hole ( refer to Figure 20 ).

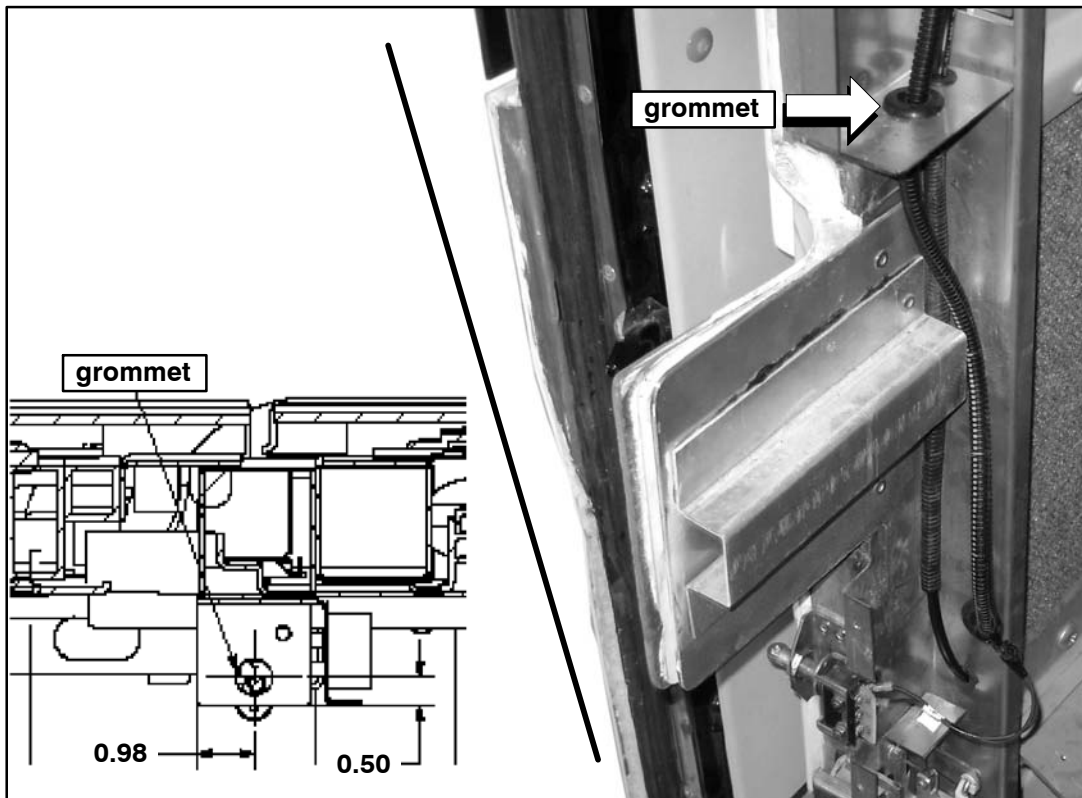

**Figure 20.**

24. Route and install solenoid adapter harness, p/n 07-12-3066, in the following order:
- Starting at the lower, RH side of upper door ( refer to Figure 14 ),
  - Pass the solenoid adapter harness through grommet installed in Step 22. , and route harness to the top, LH side of the door. Locate existing harness that was disconnected to existing switch and actuator in Step 20.
  - Route the lower part of the harness through existing hole that routes to battery compartment. Continue routing harness in the battery compartment until reaching grommet installed in Step 17.
  - Route harness through grommet. Continue routing harness to bracket assy-solenoid installed in Step 15.
  - Route the harness in the battery compartment to the voltage regulator ( use existing harnesses as reference ).
25. Use tywraps, p/n 19-11-569 throughout routing to secure harness to existing harnesses.
26. Remove ring terminals on existing harness that was disconnected in Step 20. Insert pins p/n 19-11-760, seals, p/n 19-11-2048, and connector, p/n 19-11-845 ( refer to schematics in Figure 21 or 22 ).
27. Route existing harness and connect to harness adapter, p/n 07-12-3066.
28. Connect solenoid adapter harness to the switch and actuator removed in Step 20. , the assy-solenoid p/n 03-31-3265, and the 24V ignition terminal on the voltage regulator ( refer to schematics in Figure 21 or 22 ).

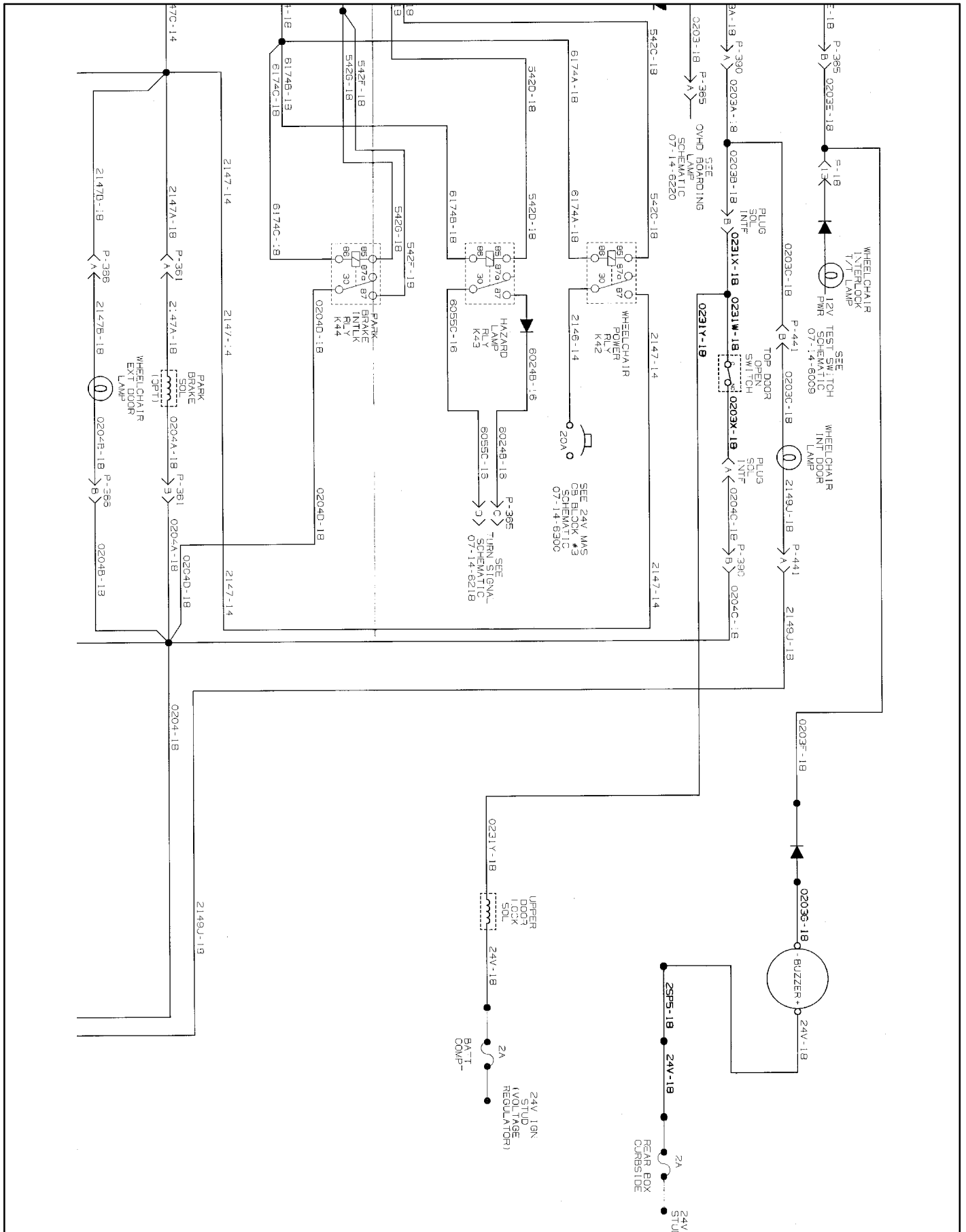

Figure 21. Schematic for non-multiplex coaches.

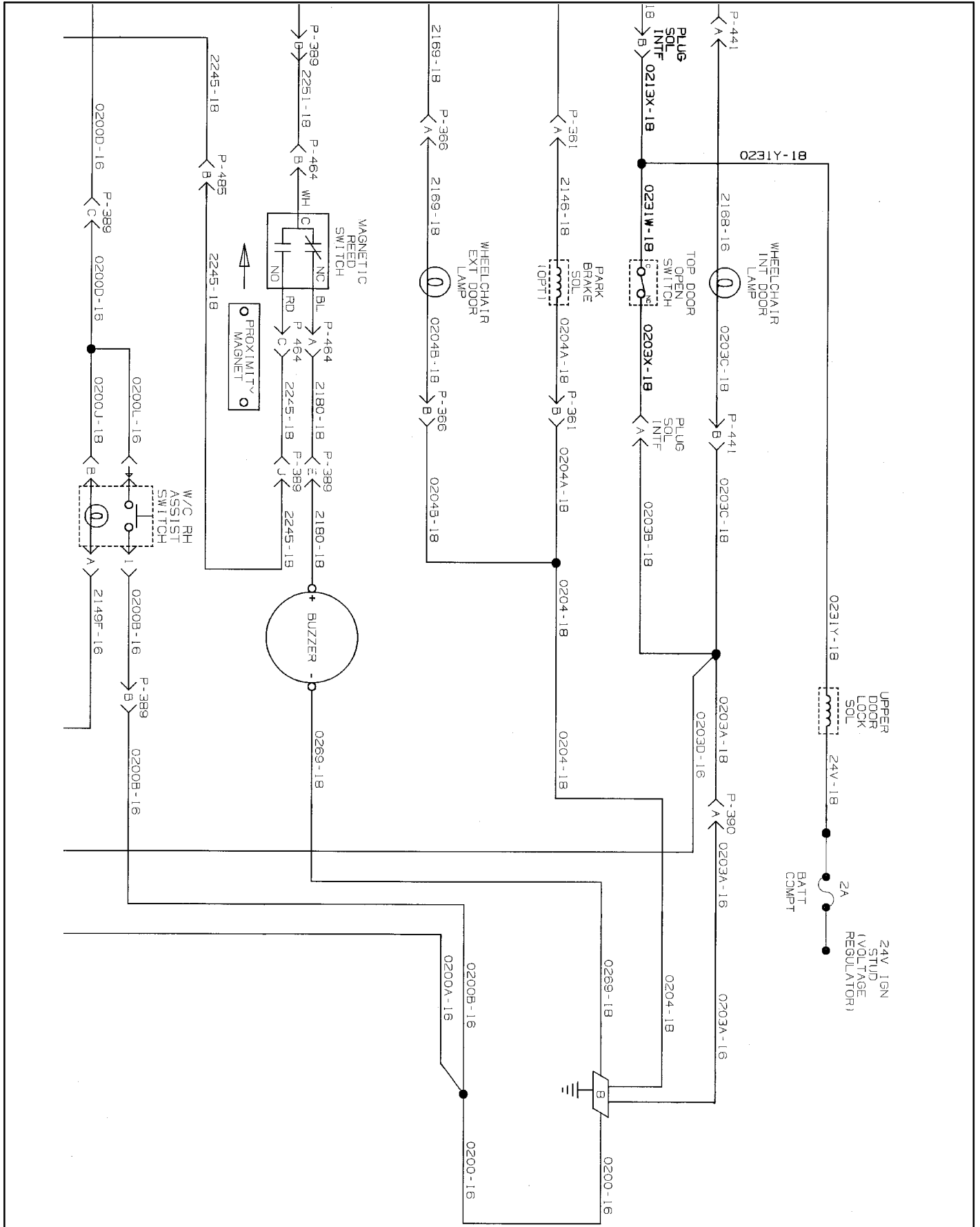
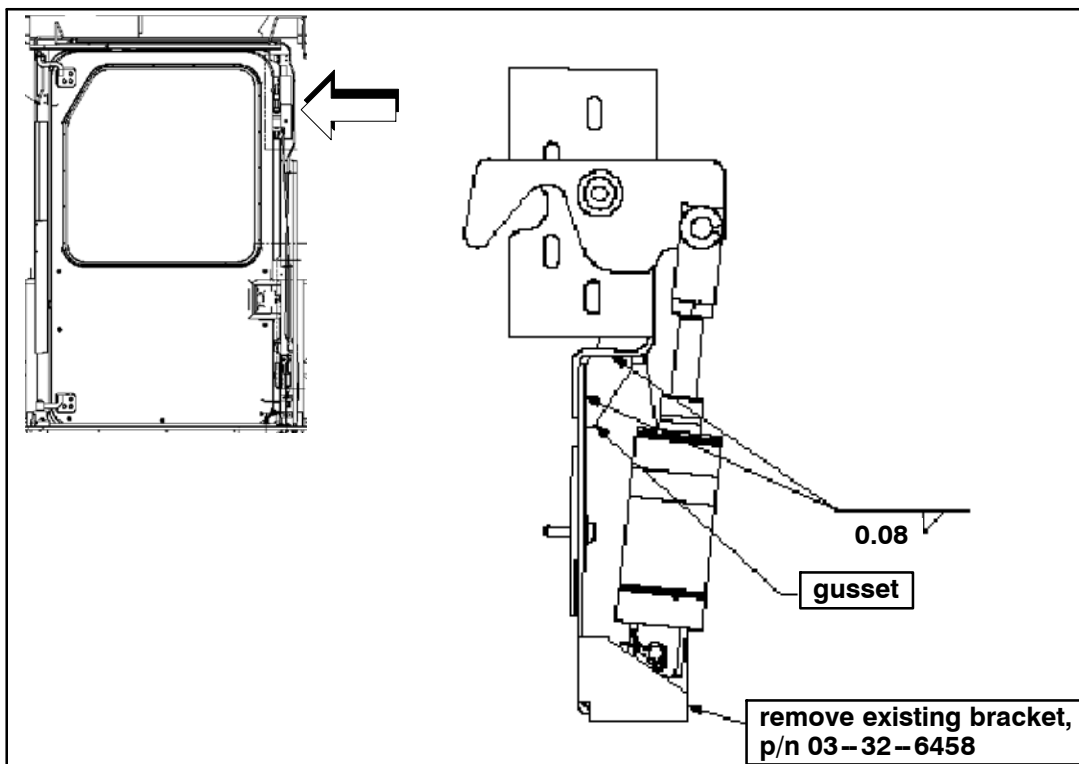

Figure 22. Schematic for multiplex coaches.

- 29. Remove existing bracket assy–cylinder upper, p/n 03–32–6458, from door ( refer to Figure 23 ) and place on a workbench. Retain mounting hardware.
- 30. Position gusset, p/n 03–31–3261, as shown in Figure 23. Weld gusset flush on existing bracket assy–cylinder upper as per specifications shown in Figure 23.



**Figure 23.**

- 31. Position gusset, p/n 03–31–3260, as shown in Figure 24. Weld gusset flush on existing bracket assy–cylinder upper as per specifications shown in Figure 24.

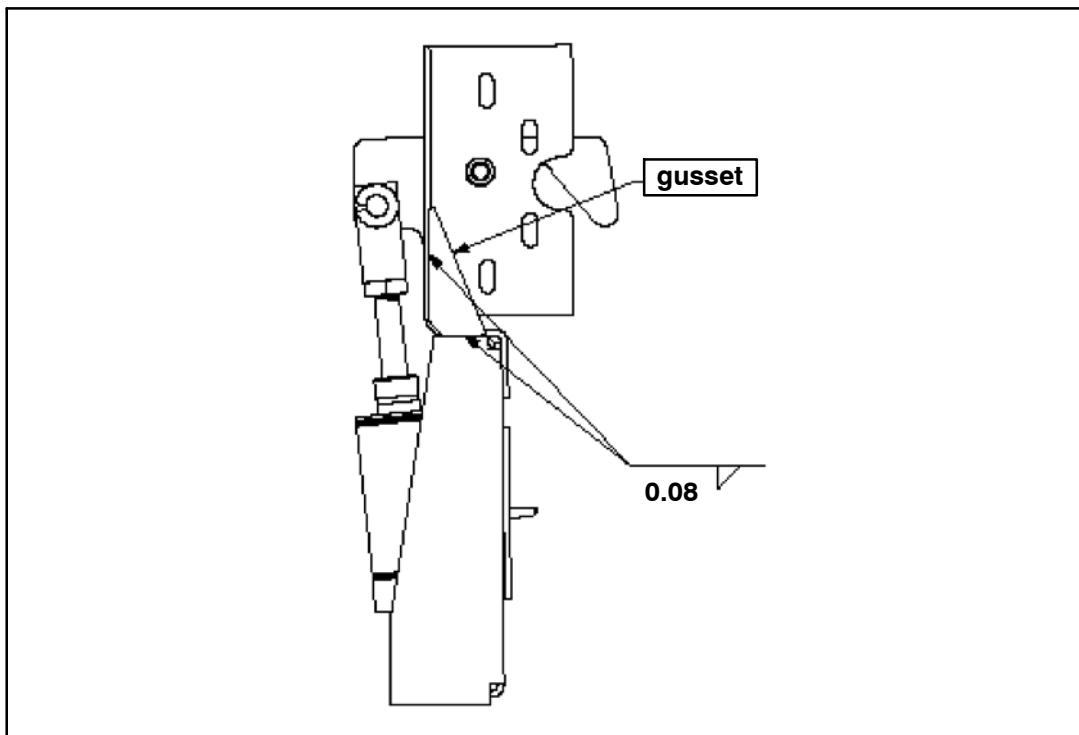

**Figure 24.**

32. Position plate, p/n 03-31-3259, as per dimensions shown in Figure 25. Weld plate on existing bracket assy-cylinder upper as per specifications shown in Figure 25

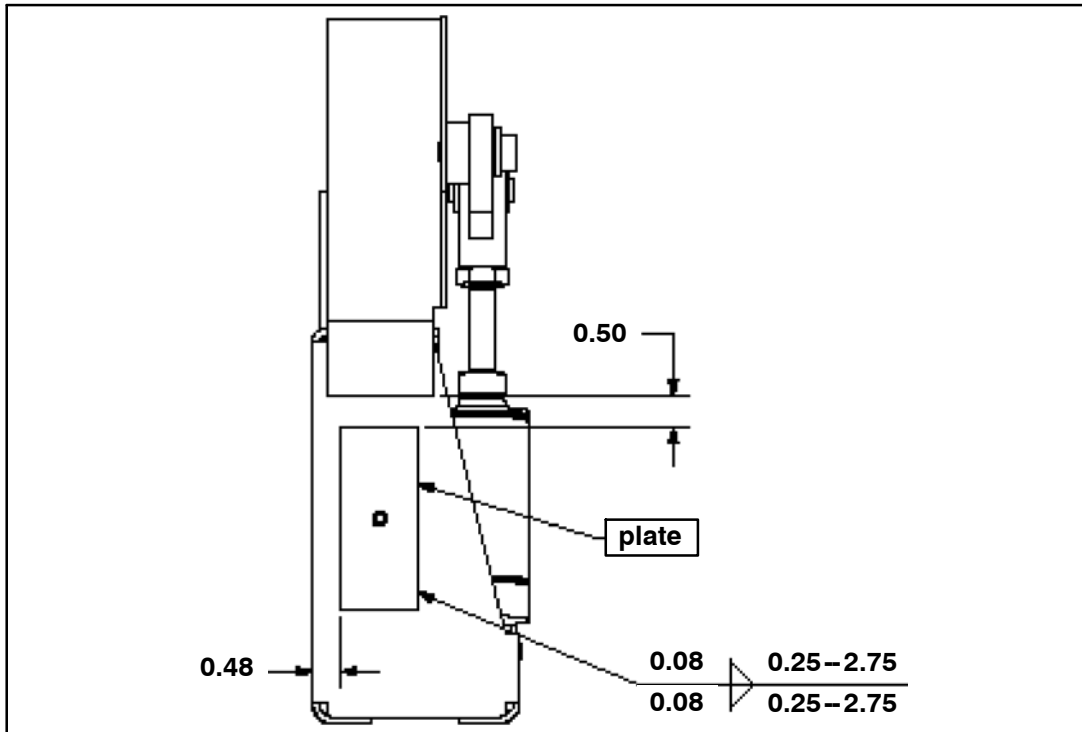

Figure 25.

## CAUTION

To prevent personal injury, allow enough time for the welds to cool down.

33. Using a 0.22 dia. drill bit and the hole on plate, p/n 03-31-3259, as a template, drill a hole into existing bracket assy-cylinder.
34. Using MCI black paint, paint the reworked bracket assy.
35. Using existing hardware removed in Step 29. , re-install the reworked bracket assy-cylinder upper.
36. Using a 0.149 dia. drill bit and the hole on the reworked bracket assy-cylinder as a template, drill a hole into the frame. Install screw, p/n 19-01-1957, into drilled hole.



**Figure 26.**

37. Route a 24 inch piece of tubing–airline, ¼ black, p/n 21–7408–155, between the existing valve, p/n 04–22–6094 and assy–solenoid 03–31–3265 ( refer to Figure 27 ). Pass tubing–airline through grommet and then connect with assy–solenoid 03–31–3265 ( refer to Figure 27 ).

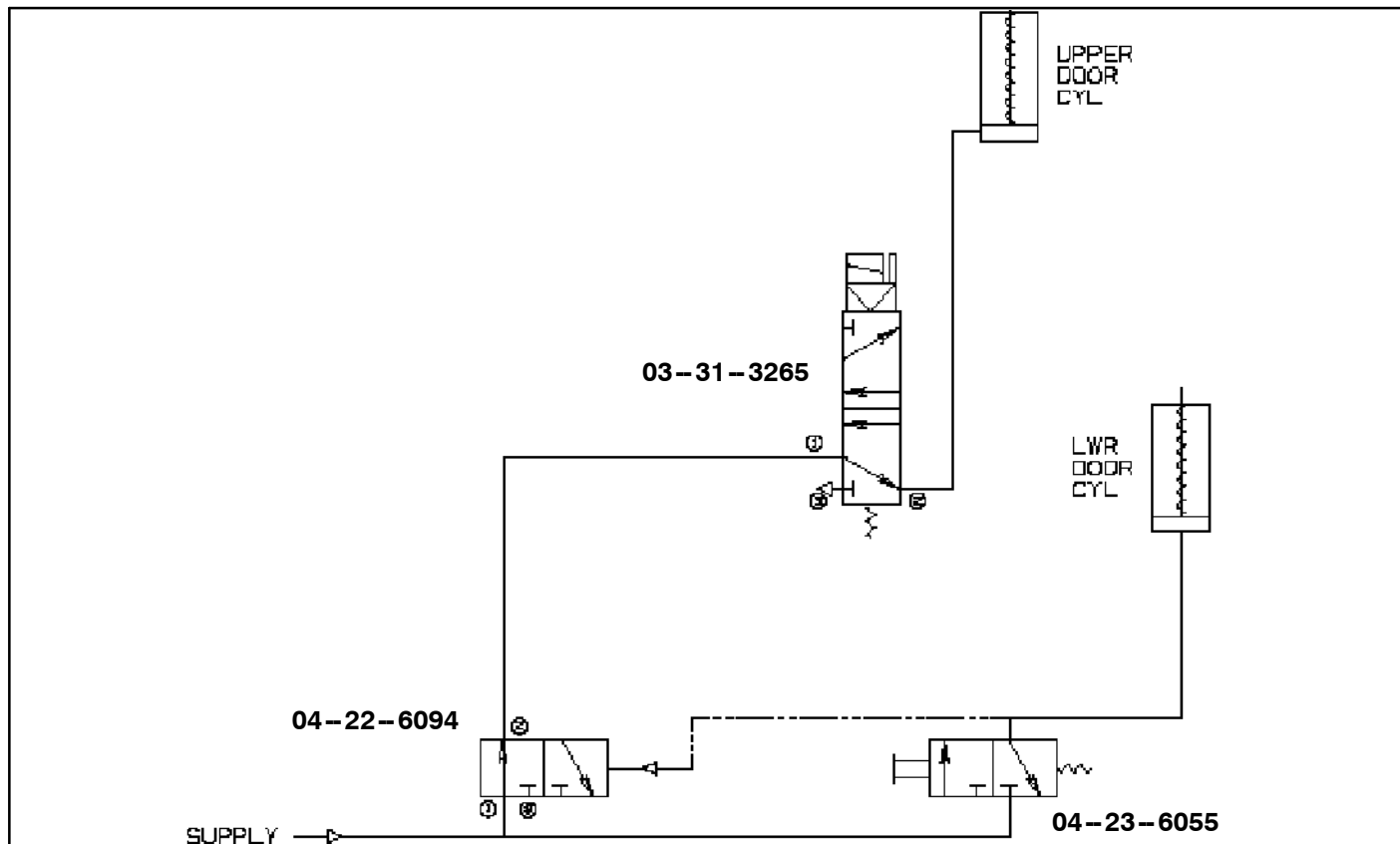

**Figure 27.**

38. Route a 76 inch piece of tubing—airline, ¼ black, p/n 21-7408-155, between assy—solenoid 03-31-3265 and existing upper cylinder ( part of reworked bracket assy—cylinder upper from Step 29. ).
39. Pass tubing—airline through grommet, then route it up through existing hole that goes to inside coach. Route it up through existing grommet and then connect it on lower port of existing upper cylinder ( part of reworked bracket assy—cylinder upper from Step 29. )
40. Adjust the position of the existing switch w/actuator as follows:
  - a. With the upper door closed, ensure the lower latch is fully closed ( to it's totally lock applied position, this latch has 2 closing steps make sure that the second step is reached).
  - b. Then, adjust the position of the existing switch w/actuator to its closed position when the door is closed.
  - c. Verify that when the door is fully closed the switch w/actuator is activated ( upper latch is applied, interior lights WCL and buzzer are OFF ).
41. Cycle door to verify that the door opens and closes properly, ensuring proper installation. Inspect to verify that the upper lock latch engages and opens properly.
42. Verify the proper operation of the new manual release lever ( located in the lift access compartment ). Pull down on the lever to release the lower mechanical latch.
43. Re-install the post covers and service module cover removed in Step 3.

## ***NOTICE***

***Coaches equipped with a multiplex system ( 80413 to 80417 and 80452 to 80518 ) proceed to Step 44.***

***Coaches that are NOT equipped with a multiplex system ( 80026 to 80412 and 80418 to 80451 ) proceed to Step 58.***

**G4500 MULTIPLEXED COACHES ( VINS 80413 – 80417 AND 80452 – 80518 )**

- 44. Release the fasteners and remove the driver defroster panel, located directly above the stepwell ( refer to Figure 28 ).

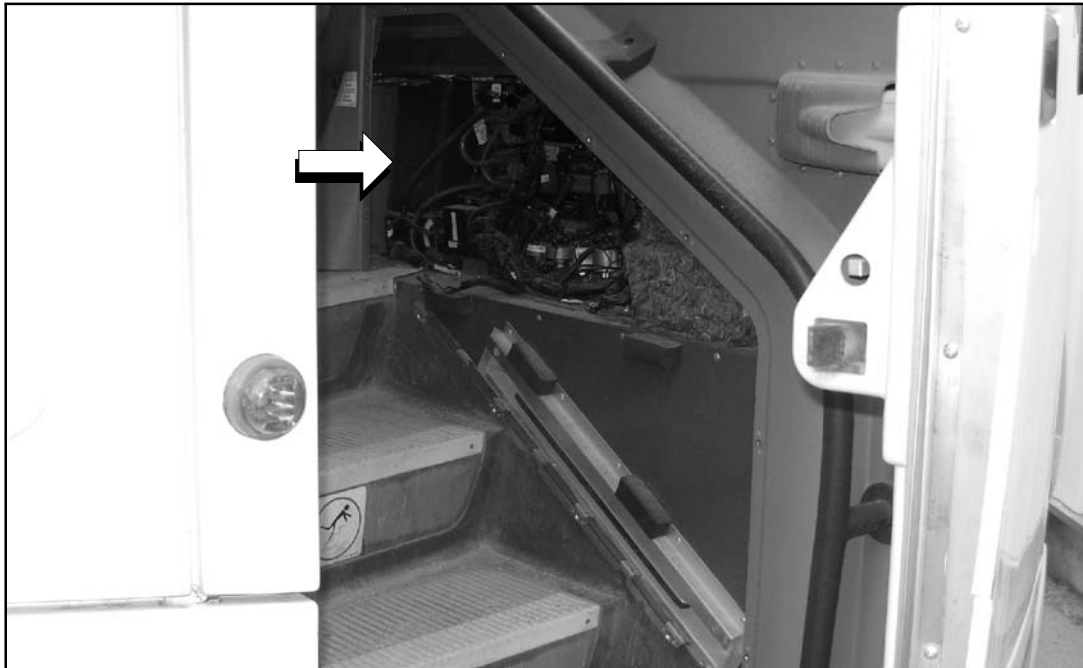

**Figure 28.**

- 45. Using a 0.149 dia. drill bit and the holes on the bracket, p/n 07-08-2796, as a template, drill two (2) holes at dimension shown in Figure 29. Using screws, p/n 19-1-758, install the bracket, p/n 07-08-2796.

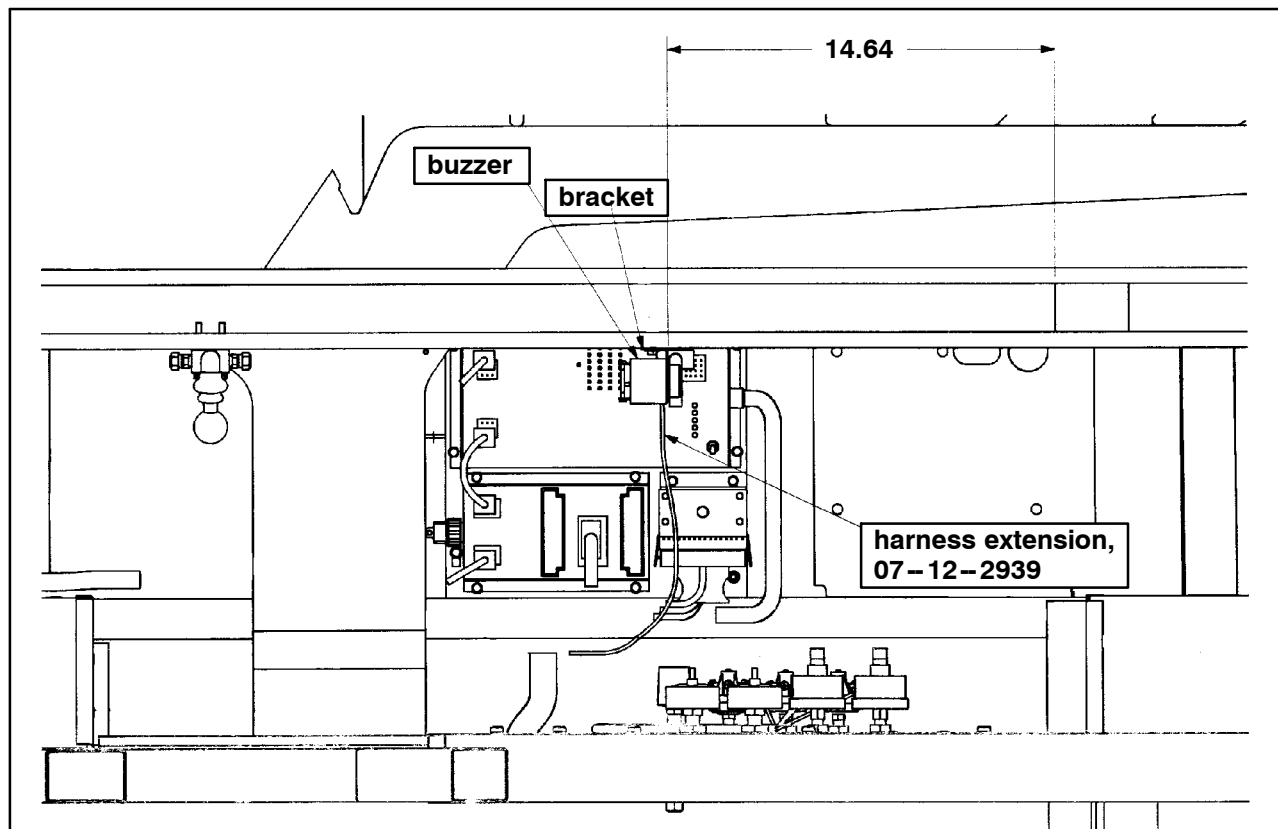

**Figure 29.**

46. Install the beeper, p/n 07-08-6252, in the bracket, p/n 07-08-2796 ( refer to Figure 30 ).
47. Locate the front main harness. Locate wire 2SP5 in the front main harness bundle.
48. Using heat shrink, p/n 19-11-1465, and solder splice, p/n 19-11-1466, splice wire 2SP5 to wire 24V on harness, p/n 07-12-2939.
49. Locate wire OSP5 in the front main harness bundle. Using heat shrink, p/n 19-11-1465, and solder splice, p/n 19-11-1466, splice wire 2SP5 to wire 0231C on harness, p/n 07-12-2939. Connect harness, p/n 07-12-2939, to beeper. Using tyrap, p/n 19-11-569, secure harness to existing harness bundle.

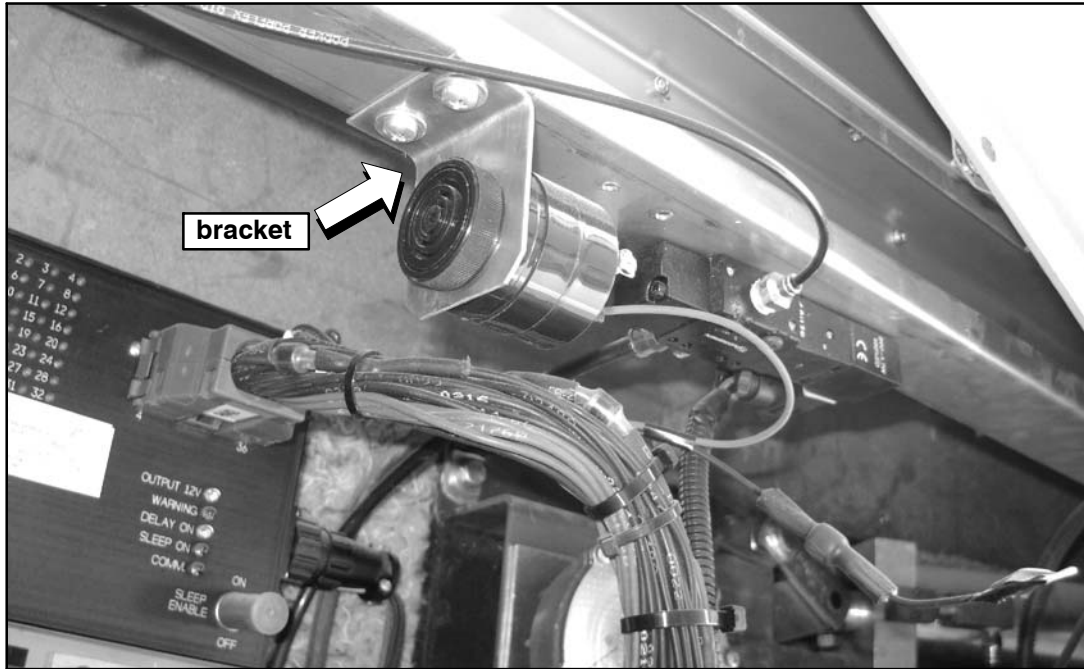

**Figure 30.**

50. Open the curbside and roadside #3 baggage bay compartment doors. Locate the junction box and remove cover ( refer to Figure 31 ).



**Figure 31. #3 baggage bay compartment.**



51. Locate wire 2SP5 in the front main harness ( refer to Figure 33 ). Using heat shrink, p/n 19-11-1465, and solder splice, p/n 19-11-1466, splice wire 2SP5 to harness, p/n 07-12-2940.
52. Connect harness, p/n 07-12-2940, to the 24V distribution stud ( refer to Figure 33 ).
53. Locate wire 0231 on P-451 (3) on Module B8. Using heat shrink, p/n 19-11-1465, and solder splice, p/n 19-11-1466, splice wire 18AWG, bk 19-11-969, three (3) inches before the connector P-451 ( refer to Figure 33 ).
54. Locate wire 0SP5 in the front main harness ( refer to Figure 33 ). Using heat shrink, p/n 19-11-1465, and solder splice, p/n 19-11-1466, splice wire 0SP5 to wire 18AWG bk 19-11-969.
55. Using tyrap, p/n 19-11-569, secure harness, p/n 07-12-2940 and 19-11-969 to existing harnesses.

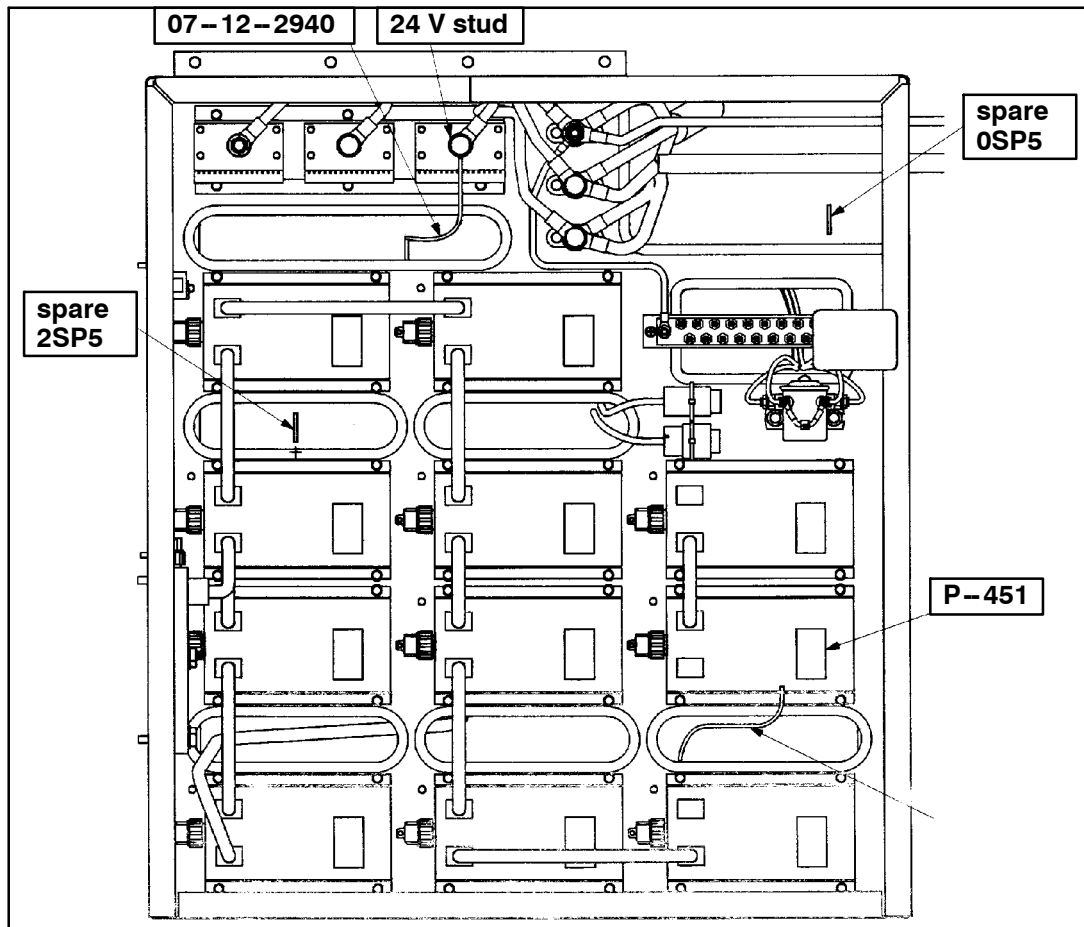

**Figure 33. #3 baggage bay compartment.**

56. Close the baggage bay compartment doors. Re-install the driver defroster panel by securing fasteners.
57. Perform outlines steps of POST-WELDING RE-CONNECTION PROCEDURE on Page 5.

**G4500 Multiplex coaches Procedure complete.**

## G4500 NON-MULTIPLEX COACHES ( VINS 80026-80412 AND 80418-80451 )

58. Release the fasteners and remove the driver defroster panel, located directly above the stepwell ( refer to Figure 28 ).

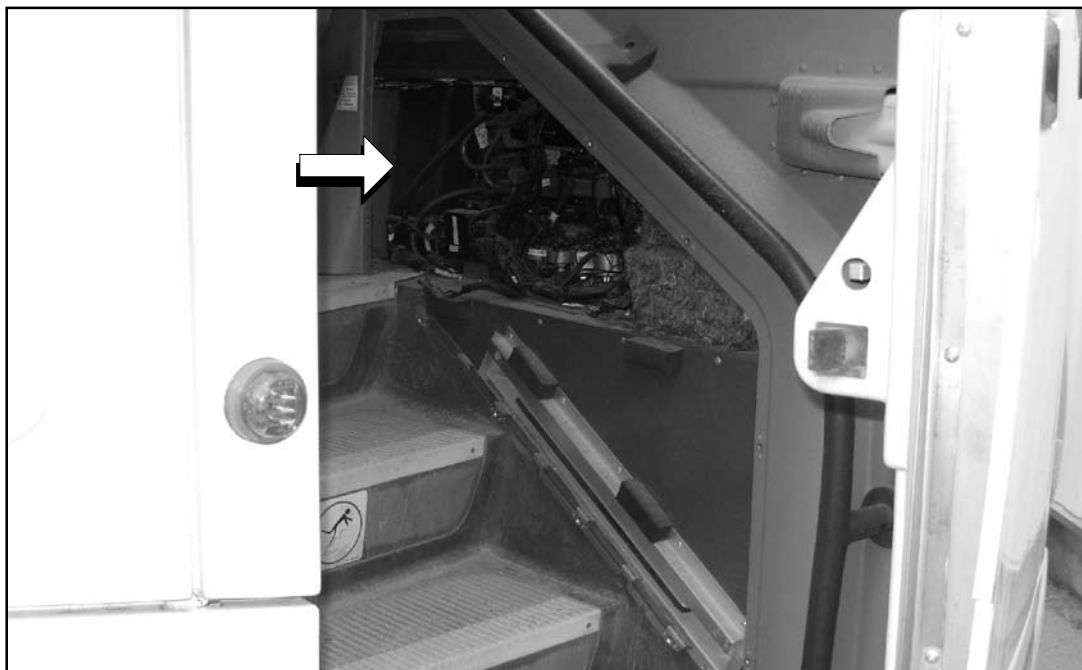

**Figure 34.**

59. Using a 0.149 dia. drill bit and the holes on the bracket, p/n 07-08-2796, as a template, drill two (2) holes at dimension shown in Figure 35. Using screws, p/n 19-1-758, install the bracket, p/n 07-08-2796.

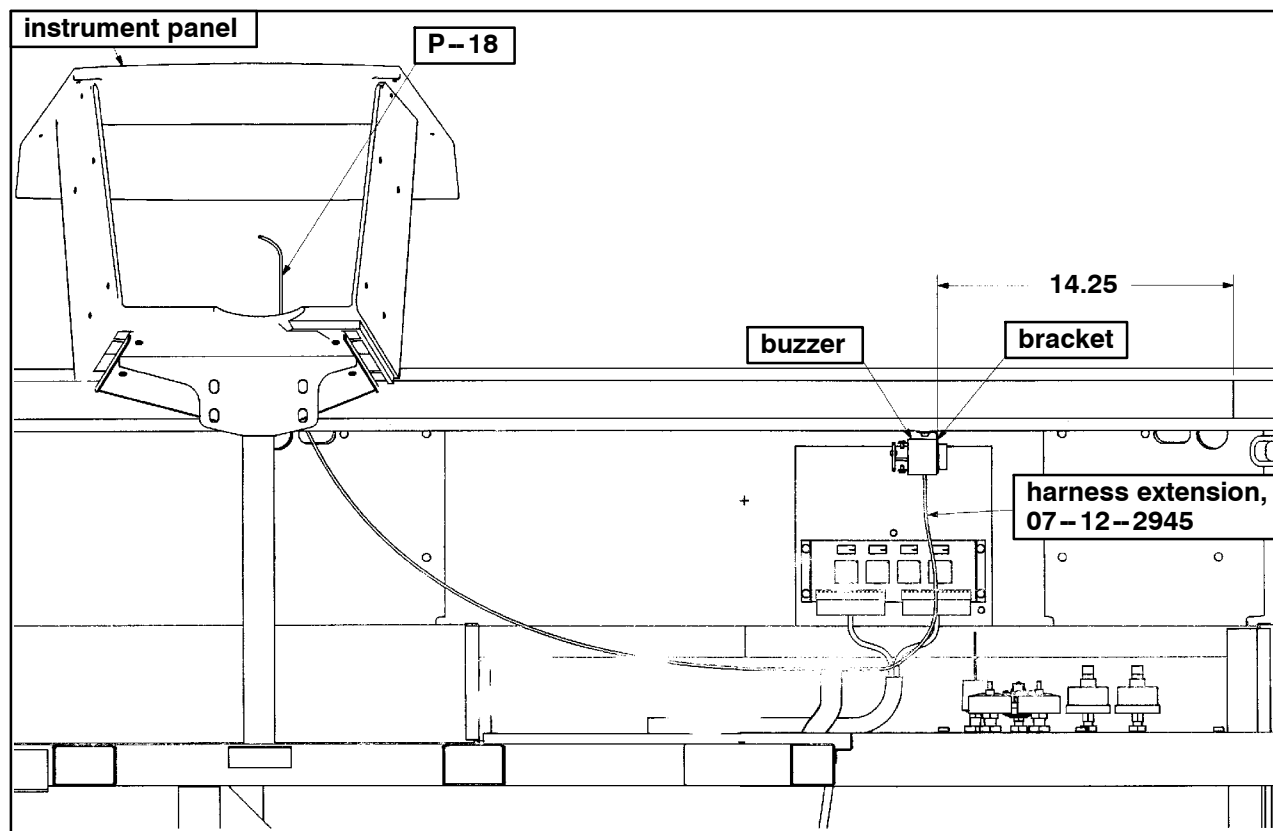

**Figure 35.**

60. Install the beeper, p/n 07-08-6252, in the bracket, p/n 07-08-2796 ( refer to Figure 36 ).
61. Locate the front main harness. Locate wire 2SP5 in the front main harness bundle.
62. Using heat shrink, p/n 19-11-1465, and solder splice, p/n 19-11-1466, splice wire 2SP5 to wire 24V on harness, p/n 07-12-2945.

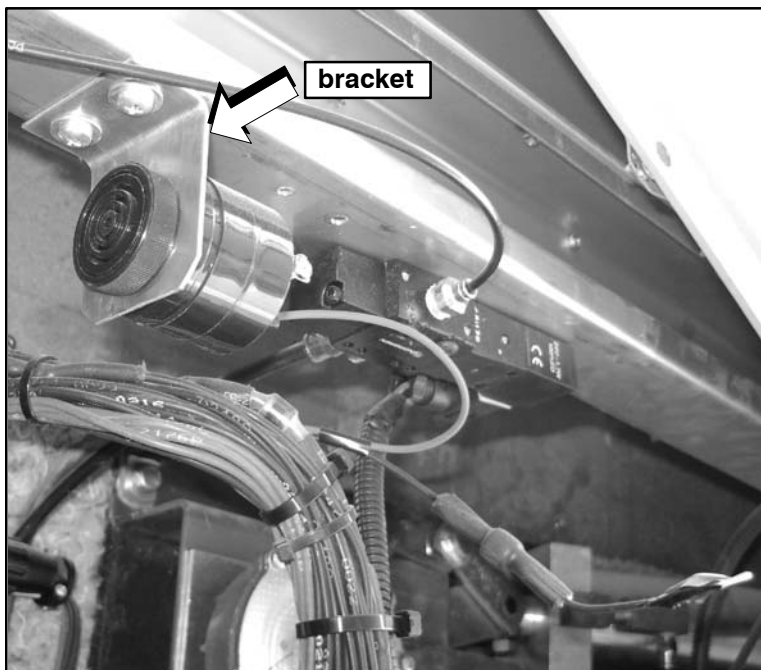

**Figure 36.**

63. Locate wire 0203E on P-18 (3) in the instrument panel connectors ( refer to Figure 35 ). Using heat shrink, p/n 19-11-1465, and solder splice, p/n 19-11-1466, splice wire 0203E to wire 0203F on harness, p/n 07-12-2945, three (3) inches before the connector P-18. Connect harness, p/n 07-12-2945, to beeper. Using tyrap, p/n 19-11-569, secure harness to existing harness bundle.
64. Open the curbside and roadside #3 baggage bay compartment doors. Locate the junction box and remove cover ( refer to Figure 37 ).



**Figure 37. #3 baggage bay compartment.**

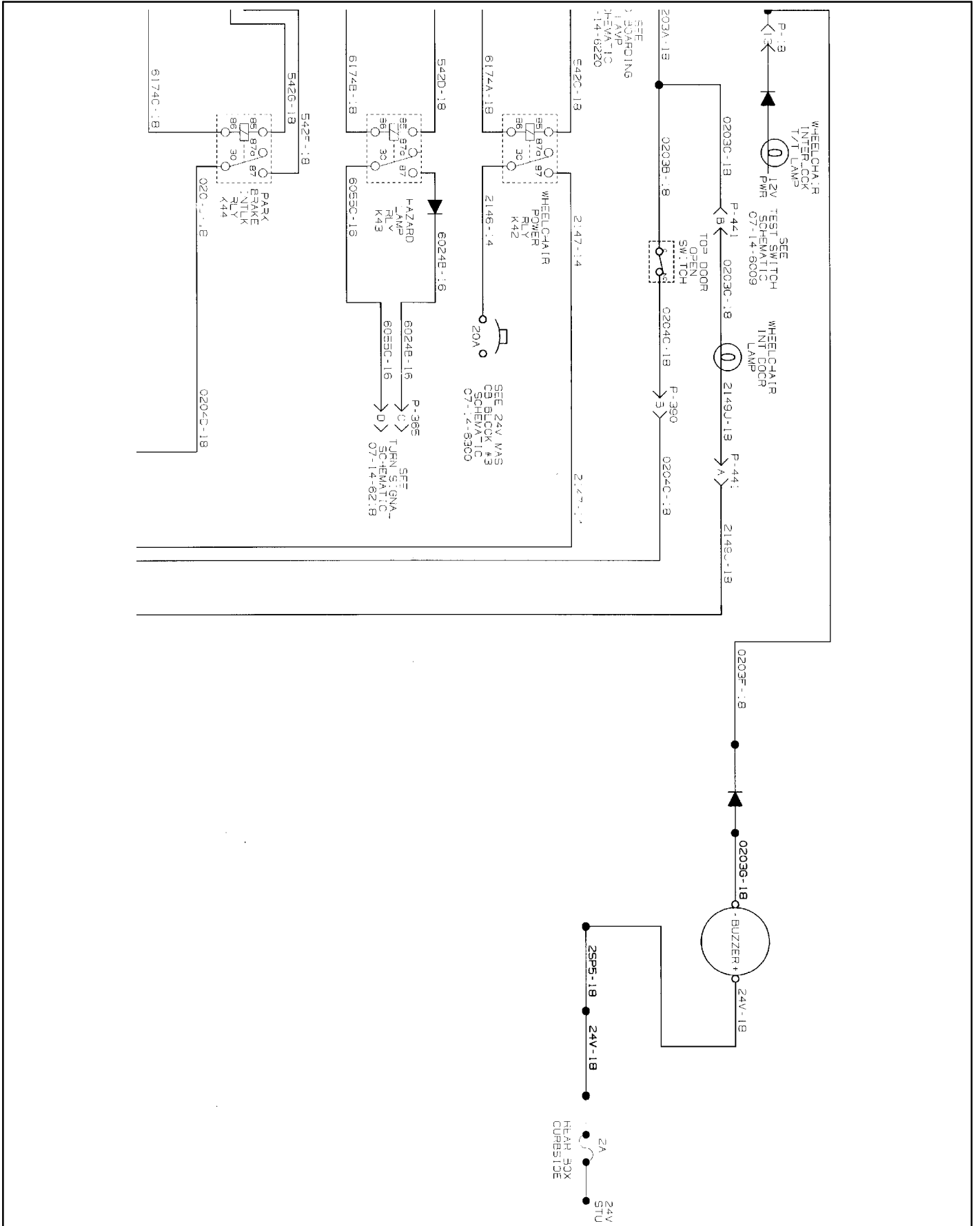
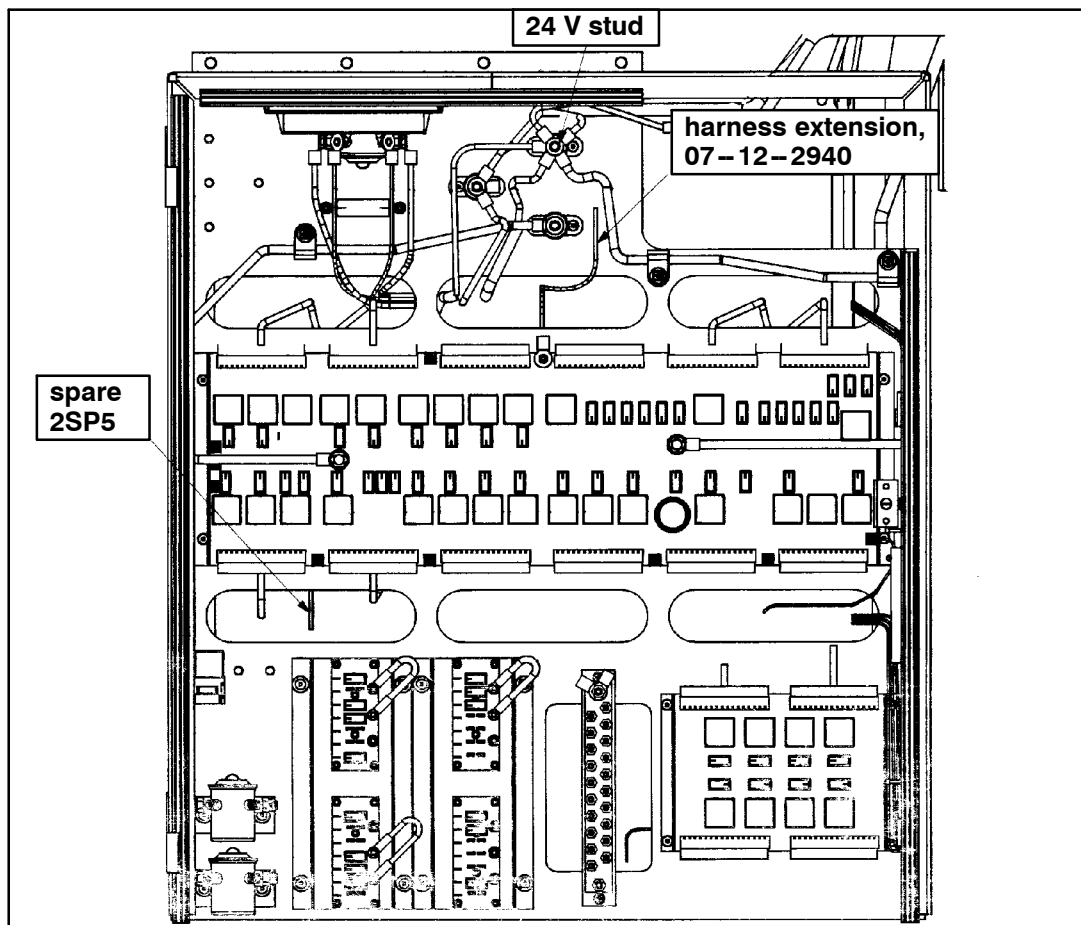

Figure 38.



**Figure 39. #3 baggage bay compartment.**

65. Locate wire 2SP5 in the front main harness ( refer to Figure 39 ). Using heat shrink, p/n 19-11-1465, and solder splice, p/n 19-11-1466, splice wire 2SP5 to harness, p/n 07-12-2940.
66. Connect harness, p/n 07-12-2940, to the 24V stud.
67. Using tyrap, p/n 19-11-569, secure harness, p/n 07-12-2940 to existing harnesses.
68. Close the baggage bay compartment doors. Re-install the driver defroster panel by securing fasteners.
69. Perform outlines steps of POST-WELDING RE-CONNECTION PROCEDURE on Page 5.

**G4500 Non-multiplex coaches Procedure complete.**

Mail or fax the completed warranty claim form to MCI's warranty department, or photocopy and mail it to:

MCI Fleet Support  
Attn: Warranty Department  
7001 Universal Coach Drive  
Louisville, KY 40258  
Fax Number 1-800-360-8886

to receive credit for the hours used to complete this task. Contact the MCI Fleet Support Technical Center at 1-800-241-2947 for any further information.

***Field Change Program Conditions:***

The parts required for this change will be supplied without charge.

**ONLY ONE ( 1 ) CLAIM CAN BE FILED AGAINST THE COACH VIN, SB 325 OR SB 325B.**

A labor allowance of 8.0 hours will be granted, for the procedure of installing the specified part(s) in this bulletin on G4500 model coaches equipped with wheelchair lift.

This labor allowance will be credited to your MCI Fleet Support Parts Account on receipt of a "Warranty Claim Form" as detailed in your Owner Warranty manual.

Motor Coach apologizes for any inconvenience resulting from this campaign, but urges you to implement this change as soon as possible.

Sincerely,

*Motor Coach Industries*  
U.S. and Canadian Service Departments.