

Recall Campaign

Daimler Trucks
North America LLC

January 2010
FL569AB
NHTSA #09V-461
REVISED NOTICE

Work Instructions

Subject: KPPS Adjustable Brake Pedals

Models Affected: Specific Freightliner Custom Chassis B2 school bus chassis (Thomas Built Buses Saf-T-Liner C2 school buses) manufactured October 6, 2004, through November 12, 2009, and XC motorhome chassis manufactured March 6, 2007, through December 11, 2009, with certain Kongsberg Power Products Systems (KPPS) adjustable brake pedals. (Please note, there are also three XB shuttle bus chassis included in this recall.)

REVISIONS: Motorhome chassis have been added as FL569B and a new kit for this group has been added. The Work Instructions have been updated to show that the C-clamp assembly comes with the top bolt pre-torqued. The procedure is the same for all vehicles.

NOTE: It is expected that all vehicles need the clamp assembly installed. An inspection is included to catch any vehicles that were repaired at the factory before delivery.

Inspection

1. Check the base label (Form WAR259) for a completion sticker for campaign FL569 (Form WAR260) indicating this work has been done. The base label is usually located above the driver's window on school buses or on the front wall under the dash on motorhomes. If a completion sticker for this campaign is present, no further work is needed. If a completion sticker is not present, proceed with the next step.
2. Park the vehicle on a level surface, shut down the engine, apply the parking brake, and chock the tires.
3. Check to see if a C-clamp or roll pin is installed on the adjustable brake pedal. See Fig. 1.
4. If either a C-clamp or a roll pin is found, no further work is needed. Clean a spot on the base label (Form WAR259), write the recall number, FL569, on a blank completion sticker (Form WAR260), and attach it to the base label. Remove the chocks from the tires.

If a C-clamp or a roll pin is not found, go to "C-clamp Installation" below.

C-clamp Installation

NOTE: The bolt threads come equipped with an application of Loctite®. The top bolt of the C-clamp assembly comes pre-torqued.

1. With the C-clamp in your hand, install the C-clamp assembly in the guide hole at the top of the brake arm casting. Make certain the C-clamp is against the casting. The bolt with the lockwasher should be installed at the top, as shown in Fig. 1, Items 4 and 5. Then tighten the bottom bolt 40 ± 5 lbf-in (452 ± 5 N-cm).
2. Clean a spot on the base label (Form WAR259), write the recall number, FL569, on a blank completion sticker (Form WAR260), and attach it to the base label.
3. Remove the chocks from the tires.

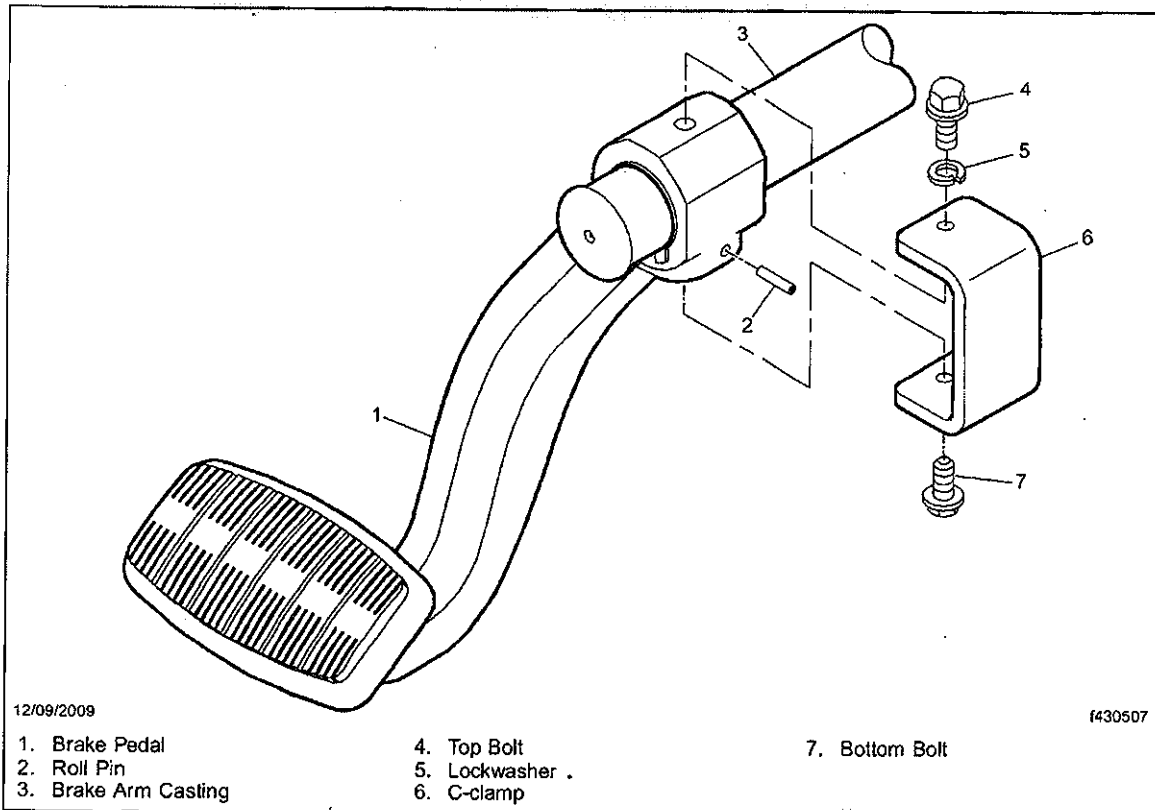

Fig. 1, Adjustable Brake Pedal Assembly