

TOYOTA

Toyota Motor Sales, U.S.A., Inc.
19001 South Western Avenue
Torrance, CA 90501
(310) 468-4000

To: All Toyota Dealer Principals, Service Managers, Parts Managers

Subject: Update – Safety Recall 90M Phase 1 (Interim Notice)



As the Safety Recall 90M remedy is now available, previous interim instructions and operation codes are no longer applicable. Please update all 90M documents using the following link.

[Safety Recall 90M – Certain 2000 – 2003 Model Year Toyota Tundra Vehicles in Severe Cold Climate States – Excessive Corrosion of the Rear Cross Member \(Spare Tire Carrier\)](#)

TOYOTA

Toyota Motor Sales, U.S.A., Inc.
19001 South Western Avenue
Torrance, CA 90501
(310) 468-4000

To: All Toyota Dealer Principals, Service Managers, Parts Managers

Subject: Safety Recall (Special Service Campaign) – 90M
Certain 2000 – 2003 Model Year Toyota Tundra Vehicle in Severe Cold Climate States
Excessive Corrosion of the Rear Cross Member (Spare Tire Carrier)
Phase I – 20 Severe Cold Climate States

On November 16, 2009, Toyota filed a Defect Information Report (DIR) with the National Highway Traffic Safety Administration (NHTSA) informing the agency of our intent to conduct a voluntary Safety Recall on certain 2000 - 2003 Model Year Toyota Tundra vehicles registered in specific Severe Cold Climate States. **Only vehicles registered in the following 20 Severe Cold Climate States and the District of Columbia are affected:**

CT, DE, IL, IN, KY, MA, MD, ME, MI, MN, NH, NJ, NY, OH, PA, RI, VA, VT, WI & WV

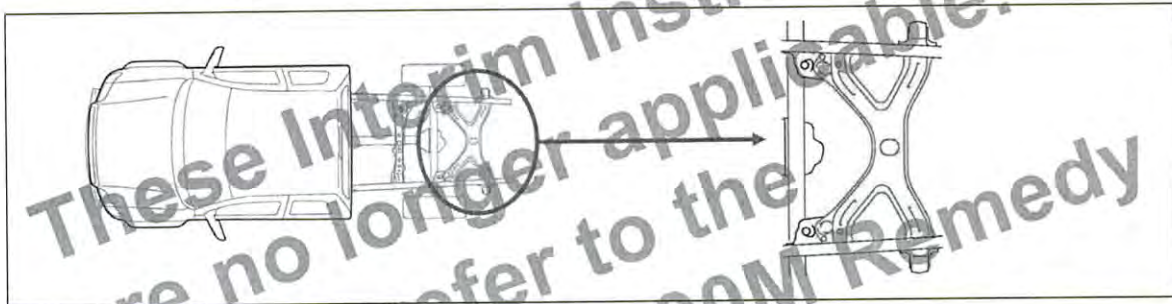

Condition

- On certain 2000 through 2003 model year Tundra vehicles operated in cold climate areas with high road salt use (*Severe Cold Climate States*) excessive corrosion may be exhibited on the rear cross-member. In the worst case, the spare tire stowed under the truck-bed may become separated from the rear cross-member. Eventually, excessive corrosion of the rear cross-member may also affect the functionality of the rear brake line at the proportioning valve.
- Exposure to cold climate and high road salt usage conditions are primary contributors. This is unrelated to, and separate from, normal surface rust which is commonly found on metallic surfaces after some years of usage and/or exposure to the environment.

1. Owner Notification Letter Mailing Date

The owner notification will commence in mid-December, 2009, approximately one week after the dealer notification. The owner letter will be mailed out over several months consistent with parts availability and repair capacity.

Two different owner letters will be sent:

- Phase 1 owner letters will be mailed to owners of Tundra vehicles registered in the affected 20 Severe Cold Climate States encouraging owners to have the campaign performed as soon as possible. A sample of the Phase 1 owner letter is included in this package.
- Phase 2 owner letters will be sent to owners in the remaining 30 states advising them of this safety recall and details on how to obtain an inspection if the owner desires it. A sample of the Phase 2 owner letter will be sent when the Phase 2 portion is ready. The VINs for phases 2 will be activated in TIS as that specific phase is launched.

Please note that only owners of the affected vehicles will be notified. If your dealership is contacted by an owner who has not received a notification, please **verify eligibility by confirming through Dealer Daily/TIS prior to performing repairs**. Dealers should perform the inspection and if necessary replacement as outlined in the Technical Instructions found on TIS.

2. Vehicles in Dealer Stock

Dealers are requested to perform SSC procedures on any vehicles in their stock prior to sale or lease. Vehicle SSC completion can be verified through TIS.

3. Dealer/Owner Lists

Affected vehicle VIN lists (VIN only due to Privacy Laws) for SSC 90M will be distributed when the repair instructions are available for Rear Cross-Member replacement.

4. Number and Identification of Involved Vehicles

There are approximately 110,000 Toyota Tundra (model year 2000 – 2003) vehicles registered in the Severe Cold Climate States involved in this SSC.

MODEL	WMI	Year	VIN Range		
			VDS	Range	
Tundra	5TB	2000	BN441	S001001 - S125840	
			BN481	S001001 - S001001	
			BT441	S001001 - S125901	
			BT481	S001001 - S125894	
			JN321	S001001 - S125878	
			KN421	S001001 - S001003	
			KN441	S001001 - S051314	
			KT441	S001001 - S125833	
			RN341	S001001 - S125859	
			RN381	S001001 - S001003	
			RT341	S001001 - S125904	
			RT381	S001001 - S125897	
		2001	BN441	S125937 - S220312	
			BT441	S125905 - S220327	
			BT481	S064335 - S220350	
			JN321	S126112 - S220343	
			KN441	S064852 - S064852	
			KT421	S090565 - S090565	
			KT441	S125921 - S220297	
			RN341	S125909 - S220341	
			RT341	S125907 - S220347	
			RT381	S064333 - S220345	
			BN441	S220394 - S332707	
			BT441	S219294 - S332720	
		2002	BT481	S219295 - S332685	
			JN321	S220351 - S332714	
			KT441	S220392 - S332706	
			RN341	S220353 - S332719	
			RT341	S220360 - S332721	
			RT381	S220365 - S332666	
			2003	BN441	S332744 - S434010
				BT441	S316368 - S439612
				BT481	S306031 - S439613
				JN321	S332745 - S436914
				KT441	S330788 - S439601
				RN341	S307943 - S436915
		RT341		S306032 - S439732	
		RT381		S308386 - S439716	
		BN441		S001001 - S125840	

These Interim Instructions are no longer applicable. Please refer to the Safety Recall 90M Remedy document.

Please note that **not all vehicles in the VIN range are affected by this SSC**. If your dealership is contacted by an owner who has not received a notification, please **verify eligibility by confirming through Dealer Daily/TIS prior to performing repairs**. Dealers should perform the repair as outlined in the Technical Instructions found on TIS.

5. **Parts Ordering**

As parts are still being prepared, parts ordering information will be provided when parts become available.

6. **Inspection Procedures**

Refer to TIS for inspection Instructions. Rear Cross-Member replacement instructions will become available in January, 2010.

7. **Customer Handling Process, if the Rear Cross-Member is Perforated**

Toyota is working quickly to make the replacement Rear Cross-Members available for this program. Until Rear Cross-Members become available in January, 2010, we request dealerships utilize the following guide to assure smooth handling of our customers. We understand there may be unique situations that requiring case-by-case handling. In these special circumstances, please contact your DSPM. They will work with your dealership to resolve issues where possible before escalating the cause.

8. **Warranty Processor Instructions**

Please note the following for this campaign:

- This SSC involves the inspection of the Rear Cross-Member, Brake Tube, LSPV and Fuel Tank Strap and if applicable the replacement of the aforementioned parts.

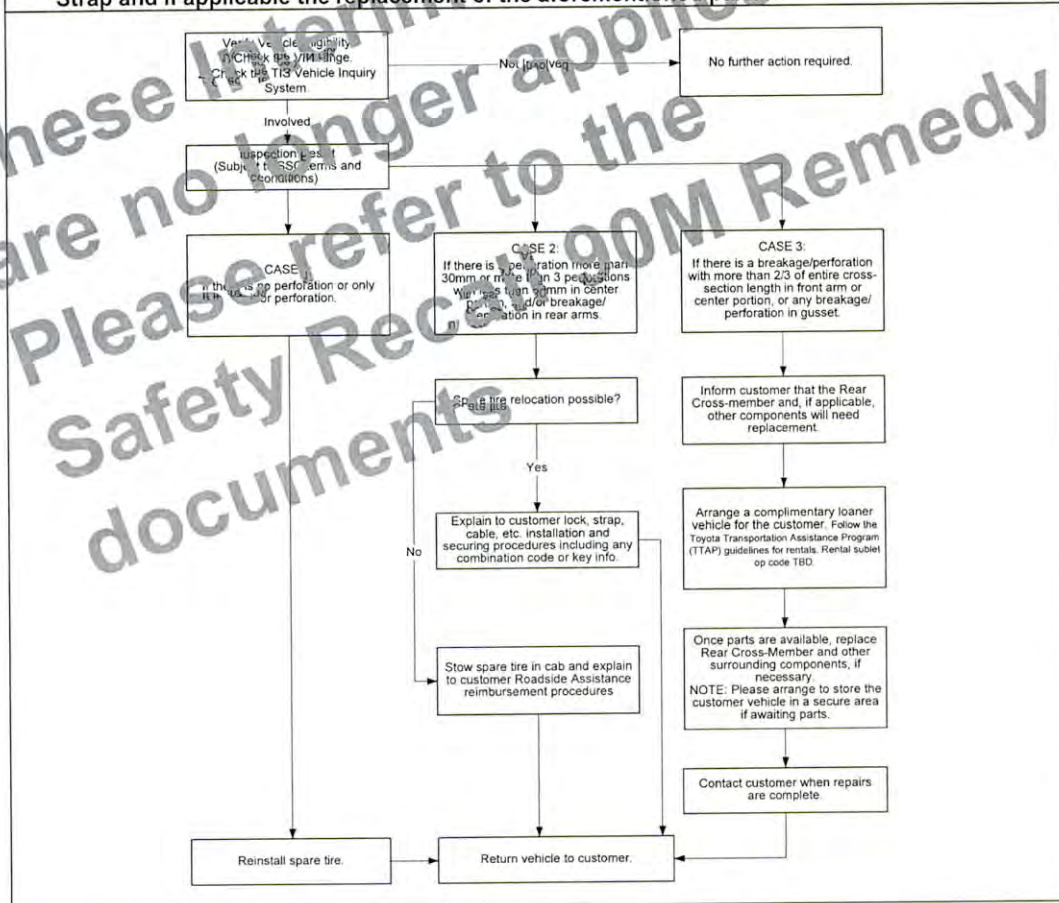

The operation code (Case 1) to be used for this campaign is:

SSC #	Op. Code	Description	Flat Rate Hour
90M	9502LA	Inspect the Rear Cross-Member and surrounding components (Brake Tube, LSPV, Fuel Tank Strap, etc.) for Rust Perforation [No Rust Perforation found (Case 1 shown in the Flow Chart)]	0.5 hr/vehicle

The following operation codes will rarely be used, as a vast majority of vehicles will not require the replacement of the Rear Cross-Member, Brake Tube, LSPV and Fuel Tank Strap(s). TMS will be monitoring the usage of these operation codes.

If Case 2 in the Technical Instructions is the result, the opcode to be used for this campaign is:

SSC #	Op. Code	Description	Flat Rate Hour
90M	9502LC	Inspect the Rear Cross-Member and surrounding components (Brake Tube, LSPV, Fuel Tank Strap, etc.) for Rust Perforation. Spare tire relocation to the truck bed if necessary or explain the Roadside Assistance reimbursement procedure to the customer. [Rust Perforation found (Case 2 shown in the Flow Chart)]	0.7 hr/vehicle

Note:

- For Operation Code 9502LC, a \$50.00 per vehicle for the cost of the straps, cable locks, etc. should be included on the SSC claim. Use "ZZ" sublet type. State "Straps, Cables, and Locks" in the sublet description. Sublet cost maximum is \$50.00.
- If the spare tire cannot be relocated to the bed, please request the customer to contact the Toyota Customer Experience Center at 1-800-331-4331 if they need reimbursement for Roadside Assistance.

If Case 3 in the Technical Instructions is the result, the opcode to be used for this campaign is:

SSC #	Op. Code	Description	Flat Rate Hour
90M	9502LB	Inspect the Rear Cross-Member and surrounding components (Brake Tube, LSPV, Fuel Tank Strap, etc.) for Rust Perforation. [Rust Perforation found (Case 3 shown in the Flow Chart)]	0.5 hr/vehicle
	9502LL	Vehicle Rental 1-30 days	Maximum \$35.00 per day

Note: For Operation Code 9502LL, use "RT" sublet type.

Rear Cross-Member replacement reimbursement procedures which will include the operation codes for the additional repair time will be released with the Technical Instructions in January, 2010.

Note: We anticipate a vast majority of vehicles will not require replacement of the Rear Cross-Member or surrounding components. Operation Codes for repair and/or replacement of the Rear Cross-Member and surrounding components (Brake Tube, LSPV, Fuel Tank Strap, etc.) will be provided in the near future. The above Operation Codes will only cover the inspection.

Submit Special Service Campaign claims following the procedures described in the Toyota Warranty Policy and Procedures Manual.

NOTE: The above flat rate times includes 0.1 hour for administrative cost per unit for the dealership.

Please review this entire package with your Service and Parts staff to familiarize them with the proper step-by-step procedures required to implement this Special Service Campaign.

Thank you for your cooperation.
TOYOTA MOTOR SALES, U.S.A., INC.

**SSC 90M – Certain 2000 through 2003 Tundra Vehicles
Severe Corrosion of the Rear Cross-Member
Safety Recall Notice (Interim Notice)**

Dear Toyota Customer:

This notice is being sent to you in accordance with the requirements of the National Traffic and Motor Vehicle Safety Act. Toyota has decided that a defect, which relates to motor vehicle safety, exists in certain 2000 through 2003 model year Tundra vehicles.

What is the condition?

On certain 2000 through 2003 model year Tundra vehicles operated in cold climate areas with high road salt use (*Severe Cold Climate States*), excessive corrosion may be exhibited on the rear cross-member of the frame. In the worst case, the spare tire stowed under the truck bed may become separated from the rear cross-member. Spare tire separation will create a road hazard for following vehicles and increase the likelihood of a crash. Eventually, excessive corrosion of the rear cross-member may also affect the functionality of the rear brake line at the proportioning valve. If this occurs, it can lead to the loss of the rear brake circuits which will increase vehicle stopping distances and the risk of a crash.

What will Toyota do?

Any Toyota Dealer will inspect the rear cross-member. During this inspection, the rear cross-member including the surrounding components such as, the brake line at the proportioning valve (which is mounted on the cross-member assembly) will also be inspected. Based upon the inspection, Toyota will do **one** of the following at **no charge** to you.

- If there is no significant corrosion of the rear cross-member assembly or the rear brake line at the proportioning valve, you will be notified of that fact and requested to subsequently bring your vehicle back to the dealership so that a corrosion-resistant compound can be applied to the rear cross-member. Toyota will notify you when the corrosion-resistant compound is available.

or

- If significant corrosion is detected such that the rear cross-member can no longer safely support the spare tire and replacement components are available, the cross-member assembly will be replaced. **In the event replacement components are not available**, a temporary solution, such as the removal of the spare tire and securing it to the truck bed, will be performed until parts are available.

In those relatively rare cases where the rear cross-member is significantly corroded and can no longer safely support the spare tire, but the rear cross-member cannot be replaced due to excessive frame corrosion at the mounting location (e.g., if the side rails are too damaged), Toyota will develop an appropriate remedy for those vehicles on a case-by-case basis.

What should you do?

This is an important Safety Recall

Please contact your authorized Toyota dealer to make an appointment to have the rear cross-member and surrounding components such as, the brake line at the proportioning valve, inspected as soon as possible. The inspection will take approximately 20 minutes. However, depending upon the dealer's work schedule, it may be necessary to make your vehicle available for a longer period of time.

This Safety Recall involves customers whose vehicles are registered in the following 20 Severe Cold Climate States and the District of Columbia.

CT, DE, IL, IN, KY, MA, MD, ME, MI, MN, NH, NJ, NY, OH, PA, RI, VA, VT, WI & WV

Until your vehicle is inspected, you may minimize the risk of the spare tire separating from the rear cross-member by removing it. If you choose to do so, please be sure not to be under the rear cross-member or spare tire carrier during the lowering process. In addition, if placing the spare tire in the truck bed or other area of the vehicle, it should be secured

when driving.

We request that you present this notice to the dealer at the time of your service appointment.

If you would like to update your vehicle ownership or contact information, please go to www.toyota.com/ownersupdate. You will need your full 17-digit Vehicle Identification Number (VIN) to input the new information.

If you have moved to another state, but would like to have your vehicle inspected, please contact your local Toyota dealer and make an appointment. Toyota will perform the same inspection and, if necessary repair, at **no charge**. Please see your dealer for details.

What if you have other questions?

Your local Toyota dealer will be more than happy to answer any of your questions and set up an appointment to perform this important Safety Recall. If you require further assistance, you may contact the Toyota Customer Experience Center at 1-888-270-9371 Monday through Friday, 5:00 am to 6:00 pm, Saturday 7:00 am through 4:00 pm Pacific Time.

If you believe that the dealer or Toyota has failed, or is unable to remedy the defect within a reasonable time, you may submit a complaint to the Administrator, National Highway Traffic Safety Administration, 1200 New Jersey Avenue S.E., Washington, DC 20590 or call the toll free Vehicle Safety Hot Line at 1-888-327-4236 (TTY: 1-800-424-9153), or go to <http://www.safercar.gov>.

What if you have previously paid for repairs to your vehicle for this specific condition?

If you have previously paid for repair to the rear cross-member and/or the rear brake line at the proportioning valve (including the proportioning valve) on your vehicle for this specific condition prior to receiving this letter you may be entitled to reimbursement of your costs for these repairs. Please mail a copy of your repair order, proof-of-payment, and proof-of-ownership to the following address for consideration

Toyota Motor Sales, U.S.A., Inc.
Toyota Customer Experience, WC 10
19001 South Western Avenue
Torrance, CA 90509

If you are a vehicle lessor, Federal law requires that any vehicle lessor receiving this recall notice must forward a copy of this notice to the lessee within ten days.

We have sent this notice in the interest of your continued satisfaction with our products, and we sincerely regret any inconvenience this condition may have caused you.

Thank you for driving a Toyota.

Sincerely,

TOYOTA MOTOR SALES, U.S.A., INC



**Special Service Campaign (Safety Recall) Q&A
Certain 2000 through 2003 Toyota Tundra Vehicles
Severe Corrosion of Rear Cross-Member**

Q1: What is the condition?

A1: On certain 2000 through 2003 model year Tundra vehicles operated in cold climate areas with high road salt use (*Severe Cold Climate States*), excessive corrosion may be exhibited on the rear cross-member. In the worst case, the spare tire stowed under the truck bed may become separated from the rear cross-member. Eventually, excessive corrosion may also affect the functionality of the rear brake line at the proportioning valve which is mounted on the rear cross-member.

Q2: Which are the Severe Cold Climate States with high road salt usage?

A2: The following states and the District of Columbia are included:
CT, DE, IL, IN, KY, MA, MD, ME, MI, MN, NH, NJ, NY, OH, PA, RI, VA, VT, WI, WV

Q2a: Why are some states contiguous to the Severe Cold Climate States not included?

A2a: Only portions of the listed states may exhibit the cold climate and high road salt usage which can cause this condition. To simplify the administration of this campaign and avoid confusion, Toyota has elected to include the entire state as a Severe Cold Climate State rather than a portion. Therefore, contiguous states not identified as a Severe Cold Climate State are not directly involved in the safety recall.

Owners of subject vehicles in other states will receive a separate notification including details on how to obtain an inspection if they desire. Toyota will perform the same inspection and repair for those vehicles at **no charge**.

Q3: What is the cause of this condition?

A3: Toyota is still investigating this issue, but tentatively, it is a combination of factors, including usage in areas where a great amount of road salt is applied, the design of the rear cross-member and manufacturing issue.

Q4: What is Toyota going to do?

A4: Owners of the affected vehicles will be notified by first class mail to bring their vehicles to a Toyota dealer for an initial inspection of the rear cross-member beginning in December, 2009. During this inspection, the rear cross-member including the surrounding components such as the brake line at the proportioning valve (which is mounted on the rear cross-member assembly) will also be inspected. Based upon the inspection, Toyota will do one of the following at **no charge** to vehicle owners:

1. If there is no significant corrosion of the rear cross-member assembly, the owner will be notified of that fact and told that he or she will subsequently be requested to bring the vehicle back to the dealership so that a corrosion-resistant compound can be applied to the rear cross-member when it becomes available.
2. If significant corrosion is detected such that the rear cross-member can no longer safely support the spare tire and replacement components are available, the cross-member assembly will be replaced.
3. If significant corrosion is detected such that the rear cross-member can no longer safely support the spare tire and replacement components are not available, a temporary solution, such as the removal of the spare tire and relocating it to the truck bed or other area, will be performed until parts are available. The owner will be notified as soon as parts are available.
4. In those relatively rare cases where the rear cross-member is significantly corroded and can no longer safely support the spare tire, but the cross-member cannot be replaced due to excessive frame corrosion at the mounting locations (e.g., if the side rails are too damaged), Toyota will develop an appropriate remedy for those vehicles.

Q4a: What if the customer has other concerns with the vehicle?

A4a: Customer satisfaction is very important to Toyota. If customers have other concerns with the vehicle we request they work with their Toyota dealer and the Toyota Customer Experience Center. The Customer Experience Center telephone number is 1-800-331-4331.

Q4b: What if the rear cross-member is intact, but other areas of the frame exhibit corrosion perforation?

A4b: The Safety Recall involves the rear cross-member. Customer satisfaction is very important to Toyota. If customers have a perforated frame on their Tundra, we request they work with their Toyota dealer and the Toyota Customer Experience Center. The Customer Experience Center telephone number is 1-800-331-4331. Toyota will make every effort to minimize customer inconvenience.

A4c: What will Toyota do if my frame is confirmed perforated?

A4c: Toyota continues to investigate perforation in other areas of the frame. Currently we are investigating each complaint on a case-by-case basis.

A4d: Will Toyota provide me a rental vehicle until the vehicle is repaired if my frame is perforated?

A4d: Each case is different, but Toyota will consider each customer circumstance to minimize their inconvenience during this time. We encourage customers to contact the Toyota Customer Experience Center at 1-800-331-4331.

Q5: What should customers do?

A5: If the vehicle is registered in the Severe Cold Climate States or the District of Columbia, customers are requested to bring the vehicle to a Toyota dealer located in one of the specific 20 Severe Cold Climate States as soon as possible. The dealer will inspect the condition of the rear cross-member, spare tire carrier and brake line at the proportioning valve and other safety-related components. Based upon the inspection results, Toyota will take one of the four actions outlined above (see "What is Toyota going to do?")

Q6: Why is Toyota not launching this Safety Recall in the remaining 30 states?

A6: Continued prolonged exposure to road salts and other severe cold climate environmental factors may contribute to the development of excessive corrosion and perforation of the rear cross-member in some vehicles. Therefore, customers in non-affected states do not need to take any action at this time.

Owners of subject vehicles in other states will receive a separate notification including details on how to obtain an inspection if they desire. Toyota will perform the same inspection and repair for those vehicles at no charge.

Q7: Why is Toyota requiring some customers with corroded rear cross-members to remove the spare tire?

A7: Toyota is currently working diligently to increase the supply of replacement parts. If rear cross-member replacement becomes necessary, but replacement components are not available, Toyota will temporarily remove and relocate the spare tire to the truck bed or other area.

Q7a: When will replacement parts be available?

A7a: Toyota is producing the replacement rear cross-member components now. They will be available in the next several weeks.

Q7b: What steps can consumers take to mitigate any risk prior to completion of the recall inspection and/or repair?

A7b: Customers may minimize any risks by removing the spare tire from the spare tire carrier located underneath the vehicle. However, if stowing the spare tire in the truck bed it must be secured to the vehicle.

Q8: Which and how many vehicles are involved?

A8: There are approximately 110,000 vehicles registered in the affected Severe Cold Climate States.

	Model Year	Model	Approx UIO
USA	2000 - 2003	Tundra	110,0000 units

Q9: Are there any other Toyota or Lexus vehicles involved?

A9: This specific condition only affects certain 2000 through 2003 model year Toyota Tundra vehicles at this moment. Toyota is currently investigating other Tundra model years.

Q9a: Is this condition related to the Tacoma rust condition.

A9a: Severe cold climate conditions and high road salt usage are primary contributors in both instances. However, the Tundra is a completely different designed vehicle.

Q9b: The Tacoma frame was supplied by Dana Corp. Is Tundra rear cross-member also made by Dana Corporation?

A9b: Yes, but the frames are differently designed and built at two separate supplier plants.

Q9c: How many cases have been reported for this condition?

A9c: According to the information we received from the NHTSA, the agency has received 20 consumer complaints when the NHTSA investigation opened.

Q9d: Is Toyota considering a Tacoma-like Customer Support Program for the Tundra?

A9d: Customer satisfaction is very important to Toyota, however, it is premature to speculate at this moment. In the mean time, if a customer has a perforated frame on their Tundra, we request they work with their Toyota dealer and the Toyota Customer Experience Center. The Customer Experience Center telephone number is 1-800-331-4331. Toyota will make every effort to minimize customer inconvenience.

Q10: What is the production period of the affected vehicles?

A10: The affected vehicles were produced from January 13, 1999 to September 13, 2003.

Q11: How long will the repair take?

A11: Inspection of the vehicle will take approximately 20 minutes, however it may take longer depending upon the dealer's work schedule. Following the inspection, if the replacement of the rear cross-member becomes necessary the vehicle will need to be available for several days based upon the dealer's work schedule and parts availability.

Q12: What should customers in non-affected states do?

A12: Owners of subject vehicles in other states will receive a separate notification including details on how to obtain an inspection if they desire. Toyota will perform the same inspection and repair for those vehicles at no charge.

Q13: What if a customer has previously paid for the repair of the vehicle's rear cross-member for this specific condition as it applies to their 2000 through 2003 model year vehicle?

A13: If a customer has previously paid for repairs to the rear cross-member for this specific condition prior to receiving a letter, the customer should mail a copy of their repair order, proof-of-payment, and proof-of-ownership to the following address for reimbursement consideration.

Toyota Motor Sales, U.S.A., Inc
Toyota Customer Experience, WC 10
19001 South Western Avenue
Torrance, CA 90509

Q14: When will owners be notified?

A14: Owners of involved vehicles will receive a Safety Recall notification by first class mail beginning in December, 2009. However, involved vehicle owners may contact their dealership without the letter if they have a concern.

Q15: What should an owner do if they experience the condition, or have immediate concerns about their vehicle?

A15: If an owner has any immediate concerns they are requested to contact their local Toyota dealer for diagnosis, and if applicable, necessary repair.

**These Interim Instructions
are no longer applicable.
Please refer to the
Safety Recall 90M Remedy
documents**

PRELIMINARY INSPECTION INSTRUCTIONS

FOR

SPECIAL SERVICE CAMPAIGN

REAR FRAME CROSS MEMBER &
LOAD SENSING PROPORTIONING & BY-PASS VALVE INSPECTION

2000-2003 MODEL YEAR TUNDRA

These Interim Instructions
are no longer applicable.
Please refer to the
Safety Recall 90M Remedy
documents

I. OPERATION FLOW CHART

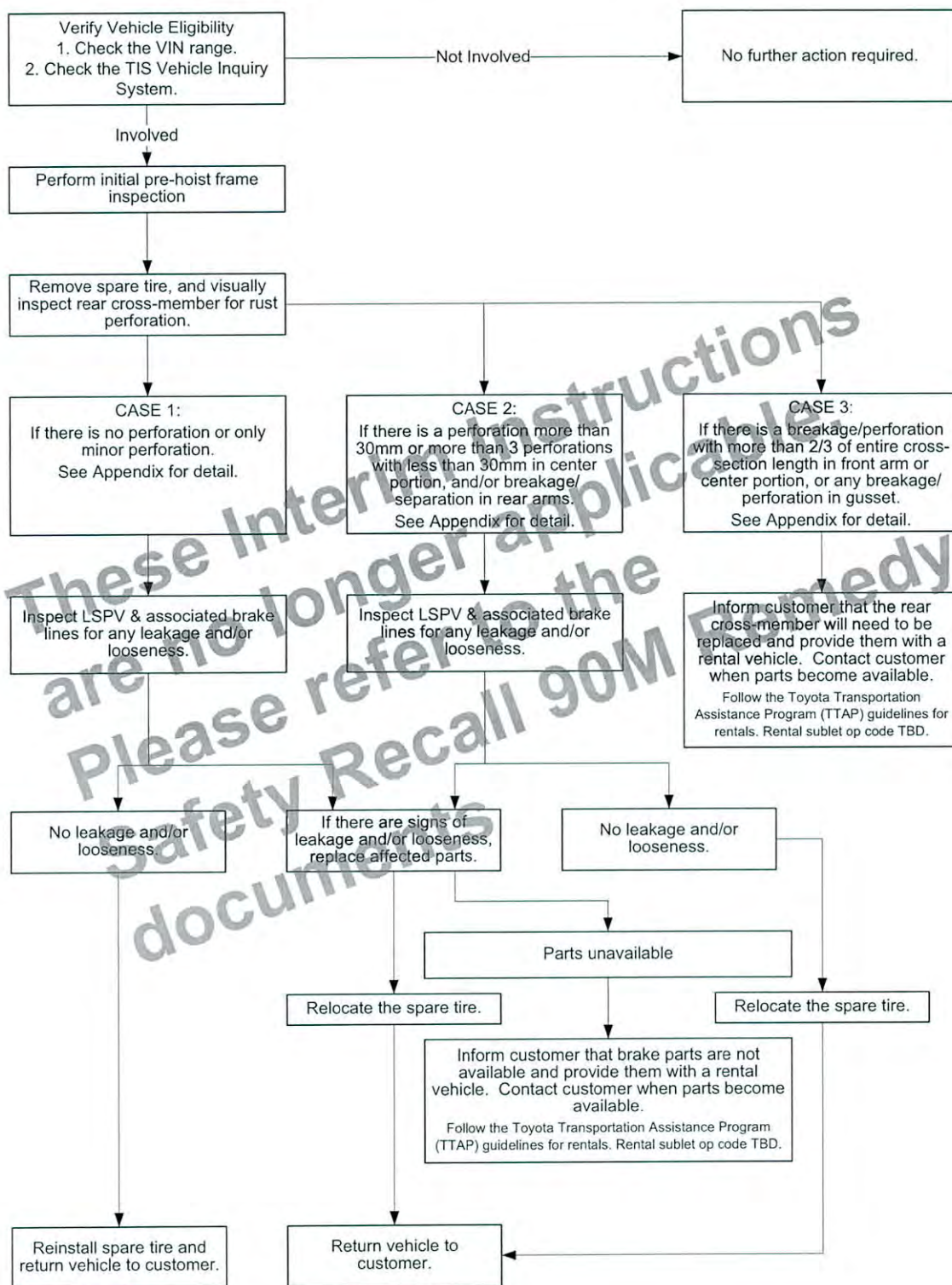

II. IDENTIFICATION OF AFFECTED VEHICLES

A. AFFECTED VIN RANGE

Model	WMI	Year	VIN Range			
			VDS	Range		
Tundra	5TB	2000	BN441	S001001 – S125840		
			BN481	S001001 – S001001		
			BT441	S001001 – S125901		
			BT481	S001001 – S125894		
			JN321	S001001 – S125878		
			KN421	S001001 – S123980		
			KN441	S001001 – S051314		
			KT441	S001001 – S125833		
			RN341	S001001 – S125859		
			RN381	S001001 – S001003		
			RT341	S001001 – S125904		
			RT381	S001001 – S125897		
			BN441	S125937 – S220312		
			BT441	S125905 – S220327		
		BT481	S064334 – S220350			
		JN321	S126112 – S220343			
		KN441	S064852 – S064852			
		KT421	S090565 – S217964			
		KT441	S125921 – S220297			
		RN341	S125909 – S220341			
		RT341	S125907 – S220347			
		RT381	S064333 – S220345			
		BN441	S220394 – S332707			
		BT441	S219294 – S332720			
		BT481	S219295 – S332685			
		JN321	S220351 – S332714			
		KT421	S220380 – S328382			
		KT441	S220392 – S332706			
		RN341	S220353 – S332719			
		RT341	S220360 – S332721			
		RT381	S220365 – S332666			
		BN441	S332744 – S434010			
		BT441	S316368 – S439612			
		BT481	S306031 – S439613			
		JN321	S332745 – S436914			
		KT421	S332818 – S414089			
		KT441	S330788 – S439601			
		RN341	S307943 – S436915			
		RT341	S306032 – S439732			
		RT381	S308386 – S439716			
				2001	BN441	S125937 – S220312
					BT441	S125905 – S220327
		BT481	S064334 – S220350			
		JN321	S126112 – S220343			
		KN441	S064852 – S064852			
		KT421	S090565 – S217964			
		KT441	S125921 – S220297			
		RN341	S125909 – S220341			
		RT341	S125907 – S220347			
		RT381	S064333 – S220345			
		BN441	S220394 – S332707			
		BT441	S219294 – S332720			
		BT481	S219295 – S332685			
		JN321	S220351 – S332714			
		KT421	S220380 – S328382			
		KT441	S220392 – S332706			
		RN341	S220353 – S332719			
		RT341	S220360 – S332721			
		RT381	S220365 – S332666			
		BN441	S332744 – S434010			
		BT441	S316368 – S439612			
		BT481	S306031 – S439613			
		JN321	S332745 – S436914			
		KT421	S332818 – S414089			
		KT441	S330788 – S439601			
		RN341	S307943 – S436915			
		RT341	S306032 – S439732			
		RT381	S308386 – S439716			
		2002	BN441	S220394 – S332707		
			BT441	S219294 – S332720		
			BT481	S219295 – S332685		
			JN321	S220351 – S332714		
			KT421	S220380 – S328382		
			KT441	S220392 – S332706		
			RN341	S220353 – S332719		
			RT341	S220360 – S332721		
			RT381	S220365 – S332666		
			BN441	S332744 – S434010		
			BT441	S316368 – S439612		
			BT481	S306031 – S439613		
			JN321	S332745 – S436914		
			KT421	S332818 – S414089		
		KT441	S330788 – S439601			
		RN341	S307943 – S436915			
		RT341	S306032 – S439732			
		RT381	S308386 – S439716			
		2003	BN441	S220394 – S332707		
			BT441	S219294 – S332720		
			BT481	S219295 – S332685		
			JN321	S220351 – S332714		
			KT421	S220380 – S328382		
			KT441	S220392 – S332706		
			RN341	S220353 – S332719		
			RT341	S220360 – S332721		
			RT381	S220365 – S332666		
			BN441	S332744 – S434010		
			BT441	S316368 – S439612		
			BT481	S306031 – S439613		
			JN321	S332745 – S436914		
			KT421	S332818 – S414089		
		KT441	S330788 – S439601			
		RN341	S307943 – S436915			
		RT341	S306032 – S439732			
		RT381	S308386 – S439716			

NOTE:

- Check the TIS Vehicle Inquiry System to confirm the VIN is involved in this SSC, and that the campaign has not already been completed prior to dealer shipment or by another dealer.
- TMS warranty will not reimburse dealers for repairs conducted on vehicles that are not affected or were completed by another dealer.

III. PREPARATION

A. PARTS

- No parts are required for the inspection.

B. EQUIPMENT & MATERIALS

- Protective eyewear
- Standard heater core hose
 - Length: 6 in.
- Ratcheting tie down strap (quantity 1)
 - Minimum Width & Length: 1 in. x 6 ft.
- Bicycle Cable Lock (quantity 1)
 - Minimum Width & Length: 3/8 in. x 5 ft.
 - Built-in lock with key
 - **Bell: P/N 1002107, Master Lock: P/N 8126D, Kryptonite: P/N 999782 or equivalent**

IV. BACKGROUND

On certain 2000 through 2003 model year Tundra vehicles operated in cold climate areas with high road salt use (*Severe Cold Climate States*) excessive corrosion may be exhibited on the rear frame cross-member. In the worst case, the spare tire stowed under the truck bed may become separated from the rear cross-member. Eventually, excessive corrosion of the rear cross-member may also affect the functionality of the brake system Load Sensing Proportioning & By-Pass Valve and/or associated brake lines.

V. WORK PROCEDURE

A. INITIAL PRE-HOIST FRAME INSPECTION

1. Visually inspect the frame for rust perforation.

- a) If NG, use a drive on vehicle lift for the inspection. Do not lift vehicle by the frame.
- b) If OK, you may use a frame contacting vehicle lift for the inspection.
- c) Proceed to rear frame cross member inspection procedure.

B. VISUAL INSPECTION OF REAR FRAME CROSS MEMBER

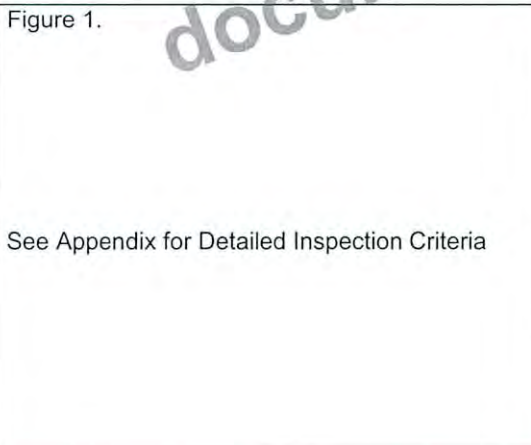

Inspect the rear frame cross member for rust perforation and ability to support spare tire.

- a. Using the decision criteria in Appendix, determine if the vehicle qualifies for Case 1, Case 2 or Case 3
 - i. Case 1: The rear cross member is not perforated by rust; proceed to section C. *Load Sensing Proportioning & By-Pass Valve and Associated Brake Line Inspection* below.
 - ii. Case 2: Proceed to section E. *Spare Tire Relocation*.
 - iii. Case 3: Inform customer that rear cross member will require replacement and provide customer with a rental vehicle.

C. LOAD SENSING PROPORTIONING & BY-PASS VALVE AND ASSOCIATED BRAKE LINE INSPECTION

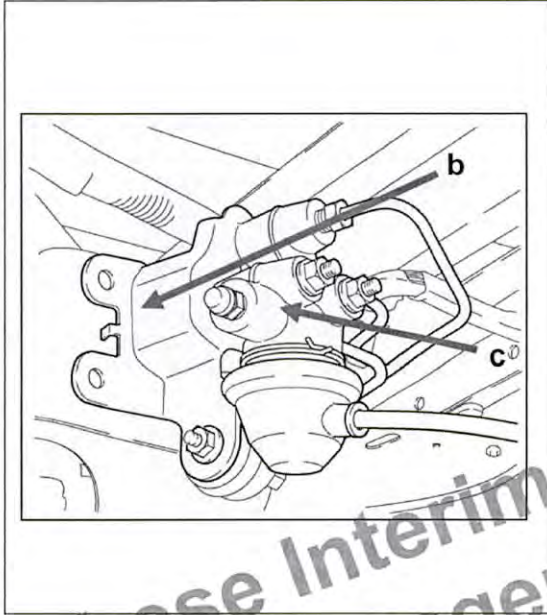

1. Inspect the Load Sensing Proportioning & By-Pass Valve (LSP & BV) for excessive rust, looseness & normal function.
 - a) If there are signs of excessive rust and/or any sign of brake fluid leakage, note that the valve will require replacement and continue inspection.
 - b) With one hand using minimal force, attempt to wiggle the **valve bracket (b)**.
 - i. If the LSP & BV bracket is loose, note that the LSP & BV and bracket will require replacement and continue inspection.
 - c) With one hand using minimal force, attempt to wiggle the **valve body (c)**.
 - i. If the LSP & BV body and/or associated components are loose or show any signs of leakage, note that the LSP & BV and bracket will require replacement and continue inspection.

D. OTHER COMPONENTS SURROUNDING THE REAR CROSS MEMBER

Inspect the components surrounding the Rear Cross-Member for breakage, damage, and/or leakage due to excessive corrosion:

- Brake lines
- Fuel lines
- Fuel tank and straps
- Exhaust pipe brackets
- Suspension mounts

E. SPARE TIRE RELOCATION

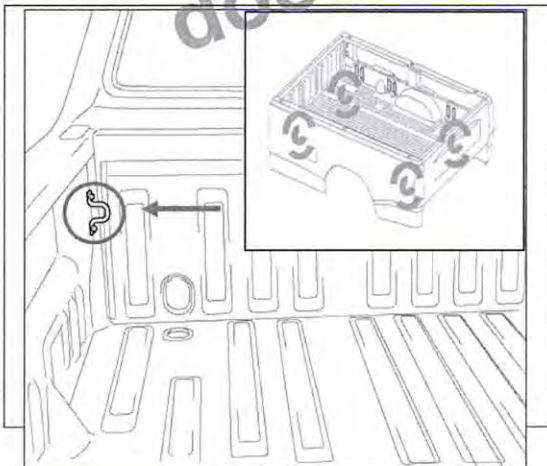

1. Selecting the spare tire relocation site.
 - a) Select a location on the bed of the truck that will accommodate the customer's needs while still allowing access to one of the four rope hooks.

NOTE:

If a suitable location in the bed cannot be found, the spare tire will need to be stowed in the cab or other location. Please explain to the customer about the Roadside Assistance reimbursement procedures.

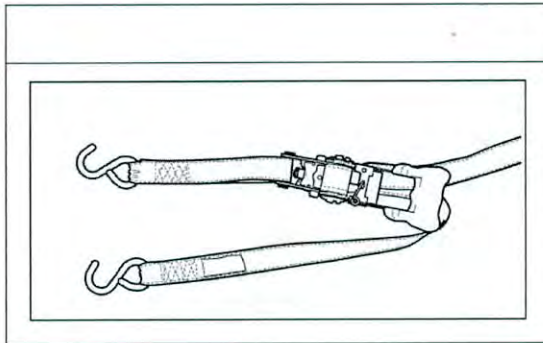

Figure 3

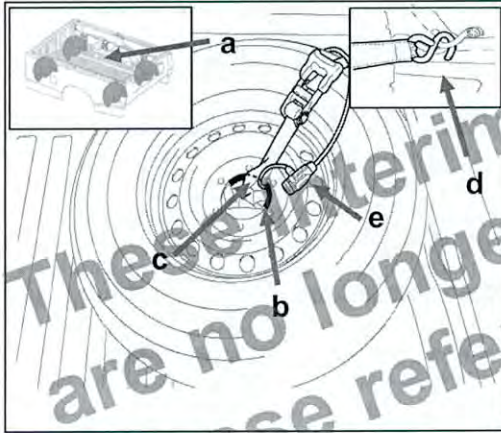
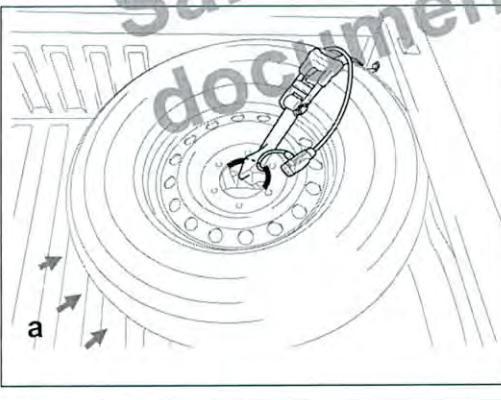

Figure 4



2. Preparing the ratcheting tie-downs.

- a) Follow the instructions included with the tie-downs to make sure that they are ready to be used with the truck and tire.

NOTE:

Improperly loading the ratcheting mechanism can lead to the failure of the locking function.

3. Placing the tire in the bed of the truck.

- a) Place the tire in the customer's preferred location.

NOTE:

If the vehicle is not equipped with a tail gate, then the spare tire can only be secured to one of the two front rope hooks.

- b) Using 6 inches of standard heater core hose or equivalent, cut a slit down the middle and slide it over the center of the wheel where the strap will make contact.
- c) With the ratcheting mechanism located on the outer sidewall of the tire, route the ratcheting tie-down strap through the center of the wheel and over the cut hose.
- d) Hook both ends of the tie-down strap to the rope hook.
- e) Route the cable lock through center of the wheel and through the rope hook and lock.

4. Securing the tire to the bed of the truck.

- a) Wedge the tire firmly against the select sides of the truck.
- b) Keeping the tire firmly in place, tighten the ratcheting strap.
- c) Take the vehicle out for a test drive to verify proper spare tire installation

NOTE:

Never operate the truck without the tire and lock being secured.

VI. APPENDIX

Guidelines for Rear Cross Member Replacement

Case 3:

Vehicle should not be driven without rear cross member replacement

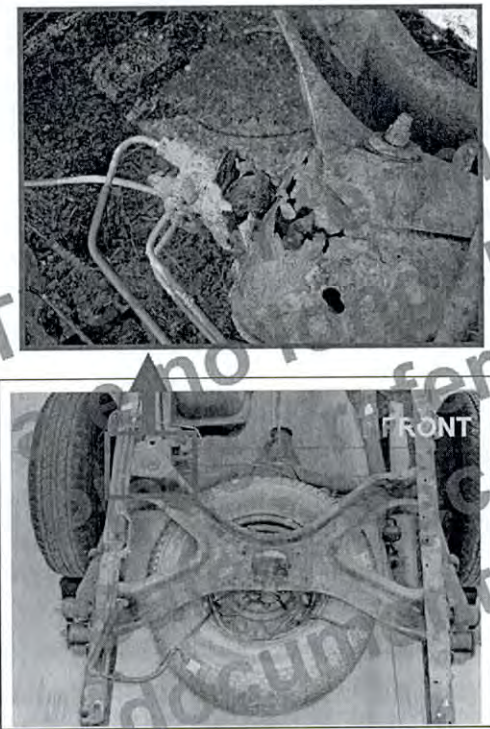
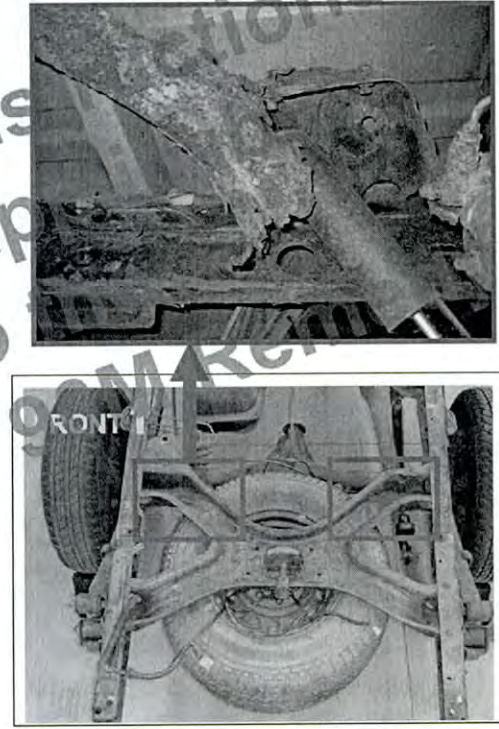
<p>Gusset Area</p> <p>Guideline: Any perforation in gusset area</p> <ul style="list-style-type: none"> - Rear LH Shock absorber mounting area - LSP&BV Bracket installation area <p>Example of NG Condition: Replace Rear Cross Member</p> 	<p>Rear Cross Member - Front Arm Areas</p> <p>Guideline: The size of the perforation is more than 2/3 of the cross section length</p> <p>Example of NG Condition: Replace Rear Cross Member</p> 
------------------------------------------------------------------------------------------------------------------------------------------------------------------------------------------------------------------------------------------------------------------------------------------------------------------------------------------------------------------	--------------------------------------------------------------------------------------------------------------------------------------------------------------------------------------------------------------------------------------------------------------------------------------------

(NOTE) Explanation of the meaning of "The length of perforation is more than 2/3 of the cross section length"

Rear Cross Member - Front Arm Cross Section

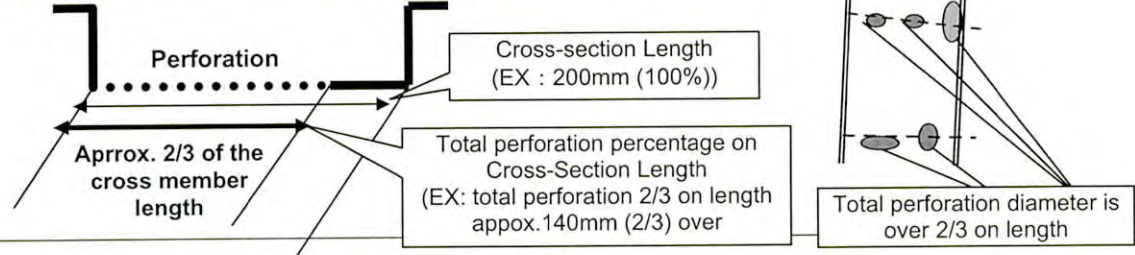

Case 3 (cont'd):

Vehicle should not be driven without rear cross member replacement

Rear Cross Member - Center Portion

Guideline: The size of the perforation is more than 2/3 of the cross section length

Example of NG Condition: Replace Rear Cross Member

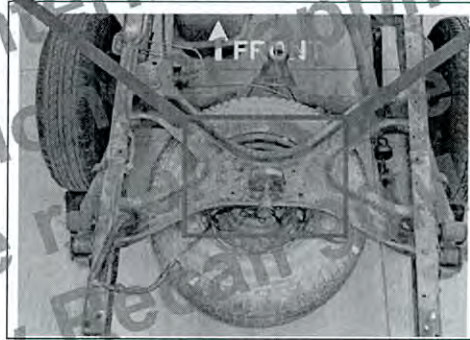

These Interim Instructions are no longer applicable. Please Refer to Safety Recall documents. Remedy

((NOTE)) Explanation of the meaning of

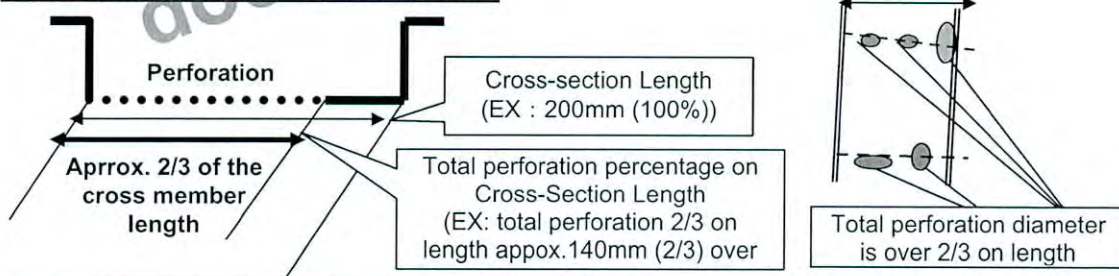

"The length of perforation is more than 2/3 of the cross-section length"

Rear Cross Member - Center Cross Section

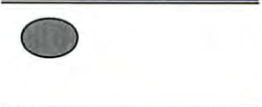
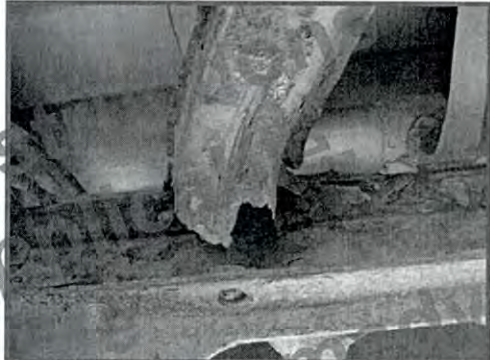

Case 2:

Vehicle can be driven without rear cross member replacement however; spare tire must be removed from carrier and secured in truck bed.

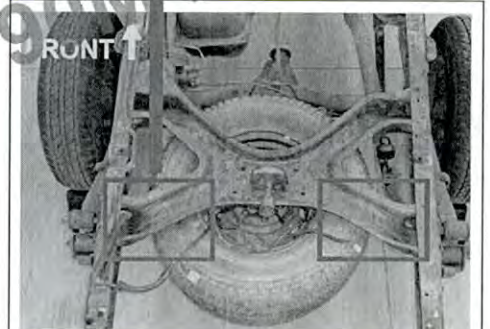
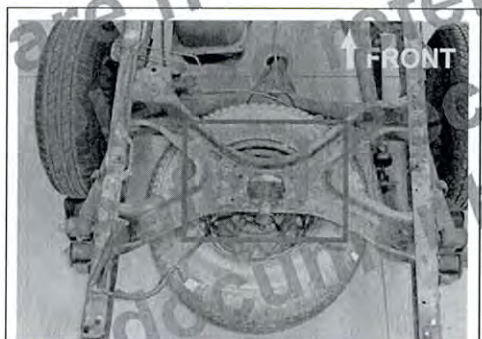
Rear Cross Member - Center Portion	Rear Cross Member - Rear Arm Area
<p>Guideline: Perforation exceeds 30 mm diameter or more than 3 perforated spots in the center portion of the rear cross member.</p>	<p>Guideline: if a complete breakage/separation from side rail is observed in rear arm of the cross-member, spare tire should be removed and secured in bed of truck.</p>
<p>Example of NG Condition: Spare tire should be removed and secured in bed of truck.</p>	<p>Example of NG Condition: Necessary to replace Rear Cross Member</p>
<p>NG Case 1: perforation exceeds 30mm diameter</p>	
 <div data-bbox="516 688 787 787" style="border: 1px solid black; padding: 5px; display: inline-block;"> <p>Single perforation over 30mm</p> </div>	
<p>NG Case 2: more than 3 perforated spots in center portion of rear cross member</p>	
 <div data-bbox="516 919 787 1029" style="border: 1px solid black; padding: 5px; display: inline-block;"> <p>More than 3 perforated spots in center portion of cross member</p> </div>	
	

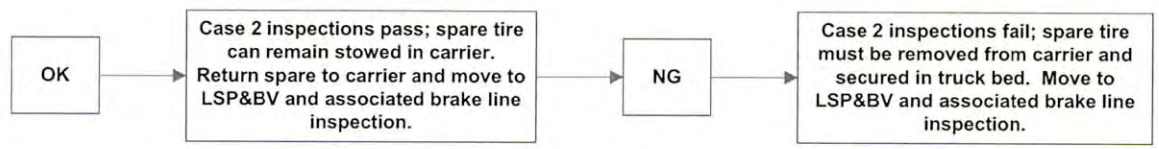

Case 1:

Spare tire can remain stowed in carrier and it is not necessary to replace rear cross member

Decision criteria: No "NG" results for Case 2 and Case 3 inspections.



A. Go to "LOAD SENSING PROPORTIONING & BY-PASS VALVE AND ASSOCIATED BRAKE LINE INSPECTION".

**These Interim Instructions
are no longer applicable.
Please refer to the
Safety Recall 90M Remedy
documents**