

ATTENTION:
GENERAL MANAGER
PARTS MANAGER
CLAIMS PERSONNEL
SERVICE MANAGER

IMPORTANT - All
Service Personnel
Should Read and
Initial in the boxes
provided, right.

QUALITY DRIVEN® SERVICE



PRODUCT CAMPAIGN BULLETIN

APPLICABILITY: 2005~06MY Subaru Baja
SUBJECT: Fuel Pump Outlet Pipe

NUMBER: WVJ-20
DATE: October 2009

INTRODUCTION

Subaru of America, Inc. has determined that certain 2005 & 2006 Baja models may have been produced with a fuel pump plastic outlet pipe that may develop cracks and potentially cause a fuel leak.

There is a potential safety risk associated with this condition. If cracks at the outlet pipe were to develop, a fuel leak could occur and pose a risk of a fire.

This recall will involve replacement of the fuel pump assembly housing.

AFFECTED VEHICLES

- All 2005 & 2006 Subaru Baja models

Affected vehicles are identified in the VIN range chart below. Prior to performing repairs, confirm coverage for potentially affected vehicles by using the Vehicle Coverage Inquiry function at Subarunet.com.

MODEL		FROM	TO
2005MY	Baja	5*100002	5*108382
2006MY	Baja	6*100001	6*107749

* Various Characters may occupy this position

OWNER NOTIFICATION

SOA will prepare and mail Owner Notification Letters to owners of affected vehicles on or around October 14, 2009.

A copy of the Owner Notification Letter is included at the end of this bulletin.

Continued...

<p>CAUTION: VEHICLE SERVICING PERFORMED BY UNTRAINED PERSONS COULD RESULT IN SERIOUS INJURY TO THOSE PERSONS OR TO OTHERS. Subaru Service Bulletins are intended for use by professional technicians ONLY. They are written to inform those technicians of conditions that may occur in some vehicles, or to provide information that could assist in the proper servicing of the vehicle. Properly trained technicians have the equipment, tools, safety instructions, and know-how to do the job correctly and safely. If a condition is described, DO NOT assume that this Service Bulletin applies to your vehicle, or that your vehicle will have that condition.</p>	<p>SUBARU OF AMERICA, INC. IS "ISO 14001 COMPLIANT" The international standard for excellence in Environmental Management Systems. Please recycle or dispose of automotive products in a manner that is friendly to our environment and in accordance with all local, state and federal laws and regulations.</p>
---	--

DEALER PROGRAM RESPONSIBILITY

Dealers are to promptly perform the applicable service procedures defined in this bulletin to correct all affected vehicles in their inventory (new, used, demo). Additionally, whenever a vehicle subject to this recall is taken into dealer new or used inventory, or is in the dealership for service, necessary steps should be taken to ensure the recall correction has been made before selling or releasing the vehicle.

New or used vehicles listed in a recall/campaign that are in dealer stock must be:

- Immediately identified.
- Tagged or otherwise marked to prevent their delivery or use prior to repair.
- Repaired in accordance with the repair procedures outlined in this Product Campaign Bulletin.

Please be advised that it is a violation of Federal law for a dealer to deliver a new motor vehicle covered by a recall under a sale or lease until the defect is remedied. Therefore, any Authorized Subaru Dealer failing to perform the applicable service procedures defined in this bulletin to correct all affected vehicles in their inventory (new, used, demo) prior to the vehicle being placed in service may be subject to civil penalties of up to \$6,000 per violation (i.e., for each vehicle), as provided in 49 USC §30165(a) of the Safety Act, and will also be in breach of the Subaru Dealer Agreement.

PARTS INFORMATION

Each affected vehicle will require replacement of the fuel pump housing. SOA will automatically pre-order and ship each dealer a supply of repair parts equivalent to 25% of their affected owner list. Dealers will need to order any additional supply through normal part ordering procedures.

DESCRIPTION	PART NUMBER
Fuel Pump Housing Kit	42029AE02A
Retainer Clamp	42037AE110

SPECIAL TOOL INFORMATION

DESCRIPTION	PART NUMBER
Fuel Line Retaining Clamp Removal Tool	42099AE000

Continued...

SERVICE PROCEDURE

This service procedure will involve replacement of the fuel pump housing and includes transferring the fuel pump, fuel level sensor, and fuel filter from the original housing to the new housing.

Fuel Pump Housing Replacement

WARNING:

- Place “Caution” signs near the work area indicating “No Fire” or “No Smoking”.
- Be careful not to spill fuel on the floor.
- Make sure there is no more than half a tank of fuel in fuel tank.

Fuel Pump Housing Removal

CAUTION: Use extreme care while performing the following steps. Gasoline contained in the fuel tank is extremely flammable.

- Do not use electrical devices, such as drop lights, or other items that could cause a spark.
- Do not allow smoking or other activities in the work area that could result in ignition of fuel vapors.
- Be sure the vehicle’s battery is disconnected as indicated in these instructions.

- 1) Raise rear seat and turn floor mat up.
- 2) Remove the fuel pump access cover.

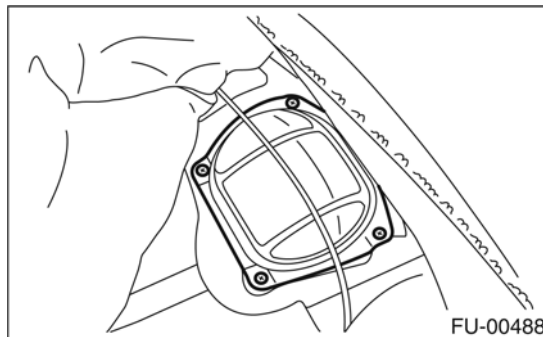

Continued...

3) Release fuel pressure:

- Disconnect the electrical connector from fuel pump.

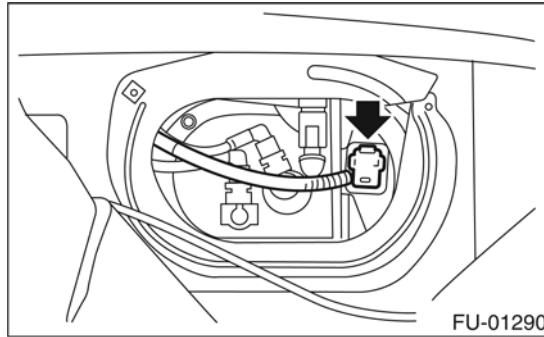

- Start the engine and run it until it stalls.
- After the engine stalls, crank it for five more seconds.
- Turn ignition switch to OFF.

NOTE: Record radio pre-set stations.

4) Disconnect battery ground cable.

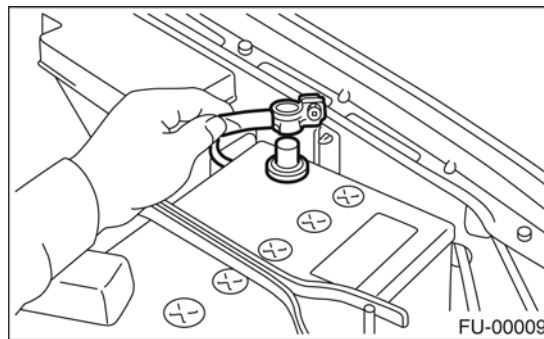

- 5) Please use caution and observe the following instructions when separating the fuel pump line connections. **Note:** The larger fuel line retainer clamp used on line “A” will be replaced during reassembly. However, the smaller retainer clamps used on lines “B” and “C” will be reused so use care not to cause damage during disassembly.

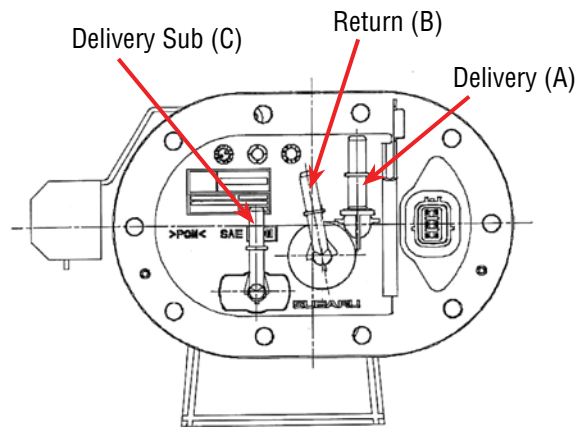

Continued...

Separation of the Quick Connector on the Fuel Pump Delivery Line (A) Only

- (1) Hold the connector and pick up the retainer clamp using your fingers.

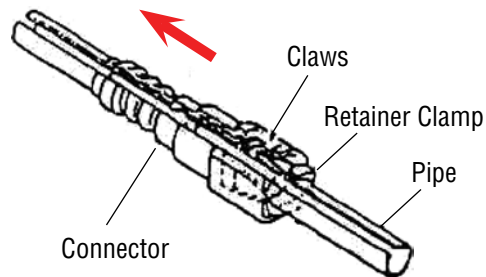

- (2) Pull out the connector from the retainer clamp.

Points to Notice

- (A) Sticking is expected between the Connector and the Pipe. Prior to separation, push and pull the connector in the pipe axis direction while holding up the retainer clamp with your fingers. Pull out the connector in the pipe axis direction after the connector becomes free. **Never wiggle or add force to the pipe from the top and bottom or right and left.**

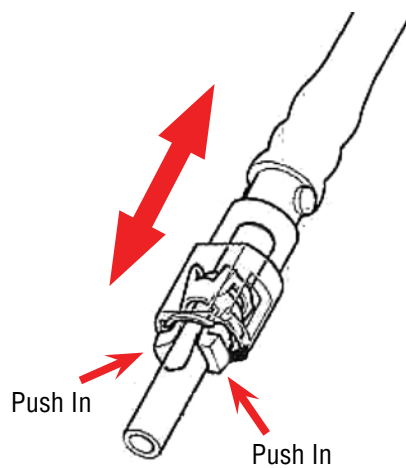

- (B) Follow the procedure below if the retainer clamp can not be lifted up using your fingers. Pick up the retainer clamp with a thin tip tool like a pair of needle nose pliers. Since the pipe must not be damaged, take care to pick up on the retainer clamp only.

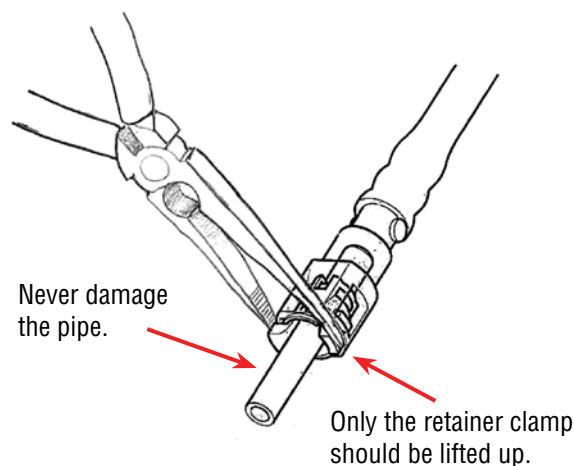

Continued...

Separation of the Quick Connector on the Fuel Pump Return Line (B) and Delivery Sub (C)

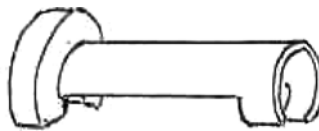

Special Tool: 42099AE000

The special tool: 42099AE000, which is set up to separate fuel hoses with quick connectors in the engine compartment, can also be used for return and delivery sub hoses. The quick connector can be unlocked by inserting the special tool around the pipe and pushing it forward as shown. Pull out and separate the connector.

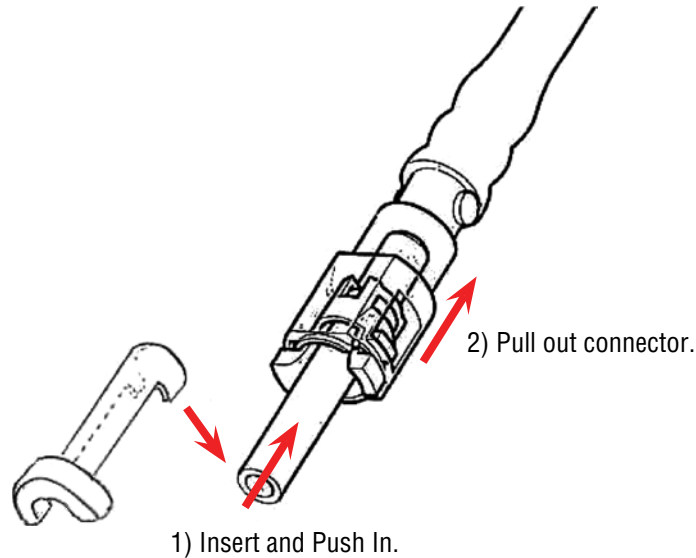

- 6) Remove nuts which secure fuel pump assembly onto fuel tank

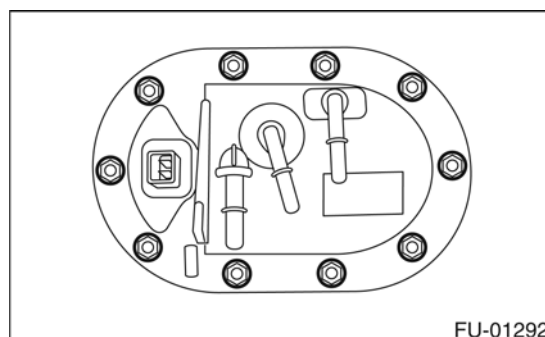

- 7) Carefully remove fuel pump assembly from fuel tank. To ease removal, lift up on the float while removing. **Do not attempt to force the pump assembly from the tank.**

Continued...

Fuel Pump Housing Component Removal & Transfer

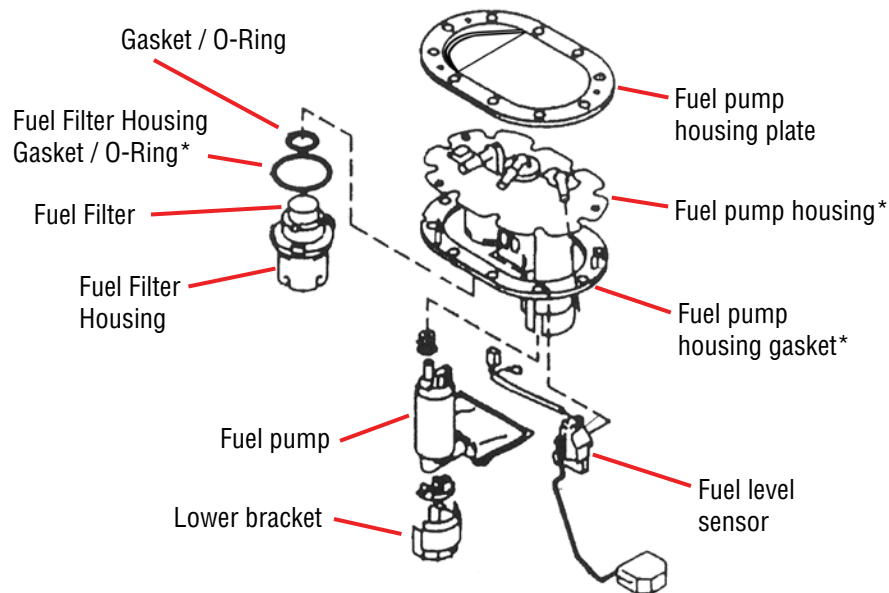

(*) Indicates replacement part contained in Fuel Pump Housing Kit P/N 42029AE02A

Fuel Pump

- 1) Remove fuel pump and pump holder from the housing by carefully spreading the two adjacent plastic pawls with just enough pressure to release the tabs. **Note:** It is not necessary to remove the pump holder or pick-up tube and sock from the fuel pump. Damage to these components could occur if attempted.

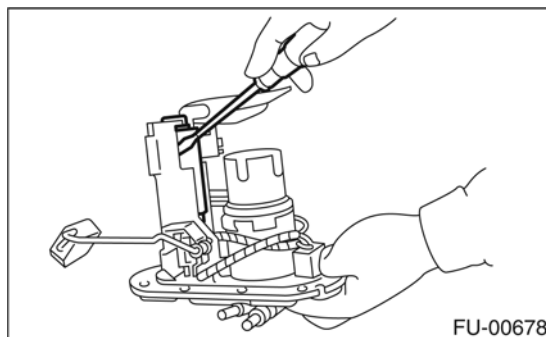

- 2) Disconnect the electrical connector from fuel pump.

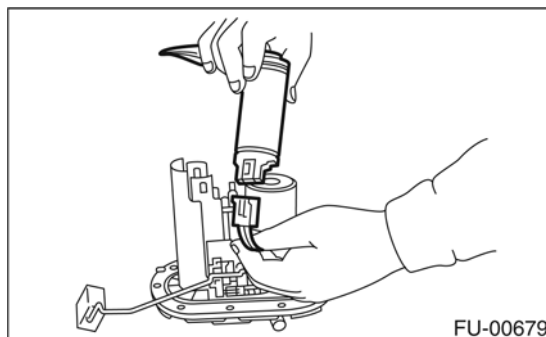

Continued...

Fuel Level Sensor

- 1) Disconnect the electrical connector from fuel pump bracket.

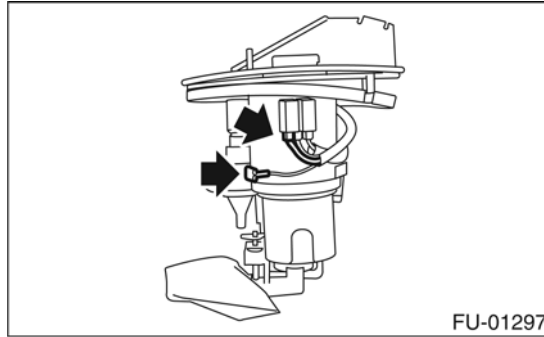

- 2) While pushing the pawls found on the back side of the fuel level sensor with a screw driver, remove the sensor by pulling it downwards. **Caution: Do not attempt to pry on the clips found at the top and bottom of the sensor as this will cause permanent damage to the sensor.**

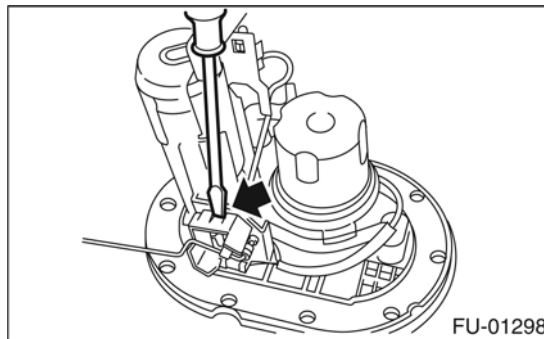

Fuel Filter and Housing

- 1) Disconnect the ground cable from filter holder.

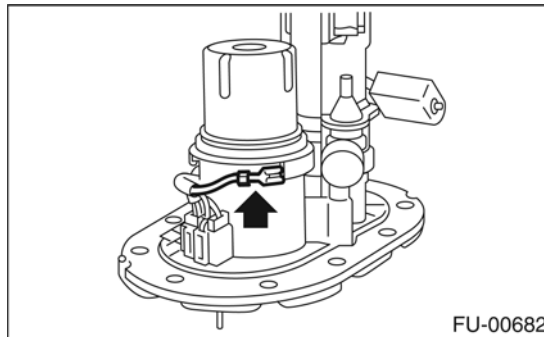

Continued...

- 2) Remove the filter holder by turning it to the left from the body pawls, and then remove the filter.

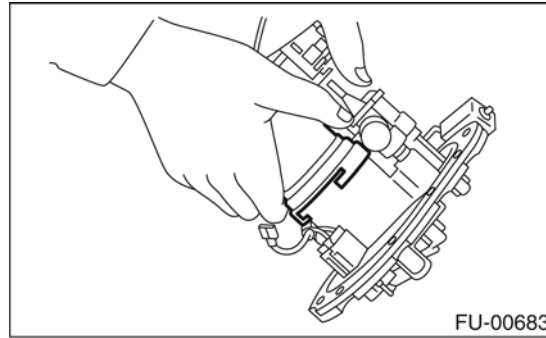

Transfer all components to the new fuel pump housing.

Be sure to use the new fuel filter housing large o-ring / gasket contained in the repair kit when installing the filter.

Install The New Fuel Pump Housing

IMPORTANT:

- Always use the new gaskets provided in the fuel pump housing kit.
 - Ensure the sealing portion is free from fuel or foreign particles before installation.
- 1) Carefully reinstall the fuel pump housing into the fuel tank using caution while inserting the fuel level float through the fuel tank opening. It will be necessary to hold the float up to avoid interference with the inner tank fuel reservoir.
 - 2) Tighten nuts in alphabetical sequence as shown to specified torque.

Tightening torque: 5.9 N•m (0.6 kgf-m, 4.3 ft-lb)

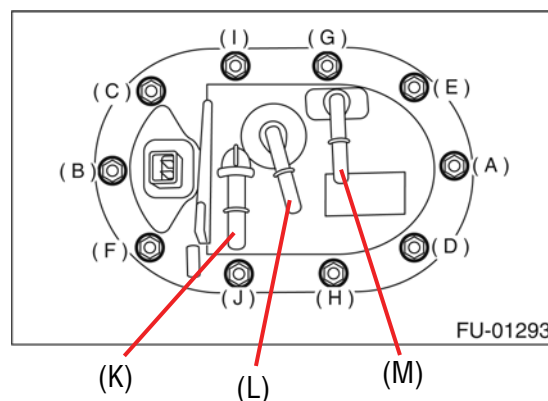

Continued...

3) Reattach the fuel lines using a new retainer clamp on the fuel delivery line (K); part number 42037AE110. Reuse the retainer clamps previously removed on lines (L) and (M). **NOTE: If any retainer clamps were damaged during removal replace with new ones.**

- When the connector is reconnected, be careful not to force, bend, or twist the pipe.
When the retainer was separated using the special tool or the retainer was replaced with a new part:
Hold the connector body with your fingers, align the axis of the pipe and the connector and then push in the pipe until the retainer clicks.
When the retainer was separated by hand:
Hold the connector body with your fingers, align the axis of the pipe, fit the retainer claw in the connector groove and push in the pipe until the retainer clicks.
- Push and pull the connector lightly several times to ensure the pipe is fully engaged with the connector. Also, visually check if the retainer claws are engaged with the connector groove at both of the two points.

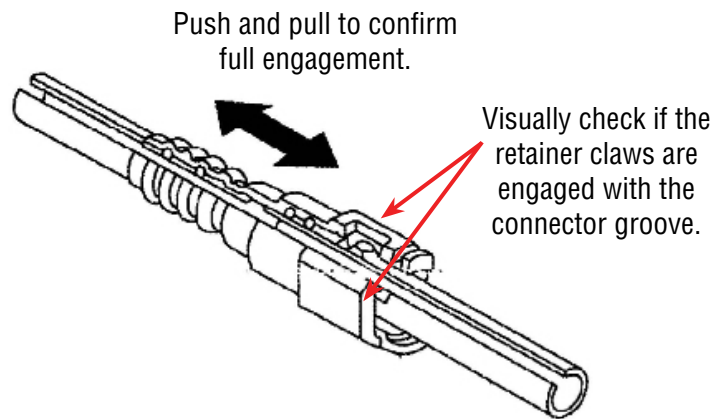

- 4) Reattach the fuel pump electrical connector.
- 5) Reconnect the battery.
- 6) Start vehicle and confirm there are no fuel leaks.
 - Raise fuel pressure in the high pressure fuel lines and check for leakage at each of the connectors, tubes and pipes.
- 7) Reinstall the fuel pump access cover and remaining components to their original condition.
- 8) Reprogram radio pre-set stations.

Continued...

RECALL IDENTIFICATION LABEL

Type or print the necessary information on a recall identification label. The completed label should be attached to the vehicle's upper radiator support.

Additional labels are available through the Customer Dealer Services Department (CDS) at 1-866- 782-2782.

SUBARU
Campaign Code
W V J - 20
COMPLETED
DIST./DEALER NO.
SERIAL NO.
DO NOT REMOVE

CLAIM REIMBURSEMENT AND ENTRY PROCEDURES

Credit to perform this recall will be based on the submission of properly completed repair order information. Dealers may submit claims through Vehicle Claim Entry on Subarunet.

CLAIM TYPE	CAMPAIGN CODE	LABOR OPERATION	LABOR DESCRIPTION	PART NUMBERS
RC	WVJ-20	A 186-901 0.6 hrs.	Replace Fuel Pump Assembly Housing	Fuel Pump Housing Kit: 42029AE02A Clamp Retainer: 42037AE110

Continued...

OWNER NOTIFICATION LETTER

Important Safety Recall Notice
Subaru Recall Campaign WVJ-20
NHTSA Recall No. 09V-277
October 2009

Dear Subaru Owner:

This notice is sent to you in accordance with the National Traffic and Motor Vehicle Safety Act. Subaru of America, Inc. has decided that a defect which relates to motor vehicle safety exists in 2005 & 2006 model year Subaru Baja vehicles.

DESCRIPTION OF THE SAFETY DEFECT

Subaru has determined that the plastic outlet pipe on your vehicle's fuel pump may develop cracks and potentially cause a fuel leak.

DESCRIPTION OF THE SAFETY HAZARD

The fuel pump is positioned at the top of the fuel tank which is located under the rear passenger seat. If cracks at the outlet pipe were to develop, a fuel leak could occur and pose a risk of a fire.

REPAIRS

To correct this condition, Subaru will replace the fuel pump bracket which contains the outlet pipe. This repair will be performed at no cost to you.

WHAT YOU SHOULD DO

You should immediately contact your Subaru Dealer for an appointment to have the fuel pump bracket replaced. Even if your vehicle was previously repaired for this condition, it is still necessary to make an appointment with your dealer to have the fuel pump bracket replaced to insure that your vehicle is equipped with the new, modified part.

Since it will be necessary for your dealer to remove the fuel pump from your vehicle's fuel tank, it would be helpful if the tank were less than half full at the time of service.

There are two important precautions you should take until this repair has been performed:

- It is highly recommended that you not park your vehicle in a garage, car port or other structure.
- If you notice the smell of gasoline, do not operate the vehicle. Immediately contact your Subaru dealer for assistance.

HOW LONG WILL THE REPAIR TAKE?

The actual time to replace the fuel pump bracket is approximately 36 minutes. However, it may be necessary to leave your vehicle for a longer period of time on the day of your scheduled appointment to allow your dealer flexibility in scheduling.

Please present this letter to your Subaru Dealer at the time this repair procedure is performed.

Continued...

IF YOU HAVE PREVIOUSLY PAID FOR A REPAIR

In the event that you have already paid for repairs associated with this condition, you may be eligible for reimbursement. The actual sum reimbursed will be equivalent to the amount Subaru of America would reimburse an authorized Subaru dealer in your area for replacement of the fuel pump bracket.

Please send the original service repair order, which has complete information including the name of the repair facility, date of repair, mileage at the time of repair, complete vehicle identification number (17 digits), and your name, with correct mailing address and telephone number to the address listed below.

Subaru of America, Inc.
Customer Dealer Services Department
Attention: WVJ-20 Recall
P.O. Box 6000
Cherry Hill, NJ 08034-6000

Please send original receipts only and retain a photocopy for your records. Please be assured that we will attempt to process your reimbursement request as quickly as possible, but may take up to 60 days for this process to be completed.

CHANGED YOUR ADDRESS OR SOLD YOUR SUBARU?

If you have moved or sold your vehicle, please complete the enclosed prepaid postcard and mail it to us.

IF YOU NEED FURTHER ASSISTANCE

To locate the nearest Subaru Dealer you can access our website at www.Subaru.com and select "Find a Dealer". Or, you may call us at 1-800-SUBARU3 (1-800-782-2783) during normal business hours for assistance. Please call us immediately if the dealer fails or is unable to make the necessary repairs free of charge or write to the address listed on the first page of this letter.

You may also contact the Administrator, National Highway Traffic Safety Administration, 1200 New Jersey Ave. SE, West Building, Washington, DC 20590 or call the toll free Auto Safety Hotline at 1-888-327-4236 (TTY: 1-800-424-9153) or go to <http://www.safercar.gov> if you believe the dealer has failed or is unable to remedy your vehicle without charge within a reasonable amount of time.

Your continued satisfaction with your Subaru is important to us. Please understand that we have taken this action in the interest of your safety and your vehicle's proper operation. We sincerely apologize for any inconvenience this matter may cause and urge you to schedule an appointment as soon as possible to have this repair performed.

Sincerely,

Subaru of America, Inc.

Notice to Lessors

Under Federal law the lessor of a vehicle who receives this letter must provide a copy of it to the vehicle lessee(s) within 10 business days from receipt. The lessor must also keep a record of the lessee(s) to whom this letter is sent, the date sent, and the applicable vehicle identification number (VIN). (For the purposes of this section, a lessor means a person or entity that in the last twelve months prior to the date of this notification has been the owner, as referenced on the vehicle's title, of any five or more leased vehicles. A leased vehicle is a vehicle leased to another person for a term of at least four months.)

A subsidiary of Fuji Heavy Industries Ltd.