



Service Bulletin No. 277C

MODEL	TYPE	SECTION/GROUP	DATE
D4500 / D4505 Series Coaches	Field Change Program	12-Suspension	Feb. 24, 2009
SUBJECT TAG AXLE / DRIVESHAFT INTERFERENCE-FIXED TAG AXLE			
CONDITIONS REVISION TO 277B-ADDITIONAL UNITS INCLUDED			

THIS BULLETIN SUPERSEDES FIELD SERVICE BULLETINS 277 & 277B IN THEIR ENTIRETY.

Ref. NHTSA Recall No.: 09V-041

Customer Complaint:

Customers may experience interference between the drive shaft U-joint bearing cap bolts and the tag axle center beam assembly. This can occur when,

- The coach auxiliary air system is depleted of air, the tag axle is forced up into the air bag bump stops and the coach is put in motion prior to this system reaching its minimum acceptable operational air pressure, and/or
- Through curbing of the axle and the tag axle is forced up into the air bag bump stops, and/or
- The coach is in low ride position and the tag axle is forced up into the air bag bump stops by uneven ground.

Cause:

The interference is due to limited clearance between the drive shaft U-joint bearing cap bolts and the tag axle center beam. This can take place when the coach is positioned such that the tag axle air springs are fully collapsed and the weight of the coach is supported by the air spring internal bumpers. Under these circumstances, interference between the bearing cap bolts and the axle center beam assembly is possible. This situation can be found on certain D4500 / D4505 coaches equipped with a Detroit Diesel Series 60 engine, a ZF transmission and a fixed tag axle.

Corrective Action:

MCI strongly encourages customers operating coaches equipped with a Detroit Diesel Series 60 engine, ZF transmission and a fixed tag axle to install the parts referenced in this bulletin to reduce the swing diameter of the driveshaft and increase the clearance, eliminating any possible interference.

As a result, MCI advises that owners of D4500 / D4505 model coaches between the range of, and including, unit numbers 56555 to 56577, 57147 to 57166, 57540 and 57544 to 57549 implement the specified steps in this procedure.

Service Procedure:

General notes

Read this entire procedure before beginning work.

Use Safe Shop Practices At All Times.



REFER TO MANUAL

Refer to Section 12 / Suspension, in the MCI D Series Maintenance Manual, in conjunction with this procedure.

Parts

Qty.	Old P/N	New P/N	Description
1		08-18-1200	Kit, Shim-Engine Mount <i>Kit Contents Are:</i>
2		08-18-1198	Shim
2		08-18-1199	Shim
2		19-01-1648	Capscrew, 7/8-14 UNF x 6
2		8G-18-154	Capscrew, 3/16-16 UNF x 5
2		19-02-0393	Washer, Flat
2		19-3-479	Nut, Lock, 7/8-14 UNF
2		19-3-480	Nut, Lock, Hex, 3/4-16 UNF
1		12-04-1082	Kit, Spacers-Tag Suspension <i>Kit Contents Are:</i>
2	12-04-1079		Plate Assembly
2		12-04-1160	Plate Assembly
2		12-04-1083	Spacer, 1.00 inch
4		19-1-240	Capscrew, 5/16-18 x 2.25
12		19-2-26	Washer, Lock, 5/16
16		19-2-8	Washer, Flat, 5/16
4		19-3-20	Nut, Hex, 5/6-18
2		12-04-1074	Spacer
4		12G-1-5	Bumper, Rubber
4		12R-1-6	Spacer, Bumper Block
2		19-1-1074	Capscrew, 5/16-18 x 1.25

1. Turn the main battery disconnect switch to the " OFF " position. Chock both sides of the tires.
2. Open the engine compartment doors. Locate the engine remote and position the ENGINE RUN and ENGINE START to the OFF position.
3. Locate the engine cradle mounting hardware shown in Figure 1 (four locations).
4. Remove and discard the existing locknuts only from the four locations shown in Figure 1.

NOTICE

DO NOT remove the capscrews at this time as they are required to maintain orientation alignment between the engine and the engine cradle.

DO NOT disconnect any engine components.

5. Position a jack under the engine, in a safe location that can support the load of the engine and transmission without any structural damage.
6. In a safe, controlled manner, jack up the engine enough to allow for spacer installation (approximately one inch).

NOTICE

The engine must be supported to avoid component damage.

NOTICE

Remove and replace ONE fastener at a time.

7. Remove and discard the existing fastener (and washer if applicable). Install appropriate shim (p/n 08-18-1198 or 08-18-1199) and new mounting hardware provided in Parts list. Tighten nut hand tight only.
8. Repeat Step 7. to next fastener.

NOTICE

The exhaust pipe may require removal to access the rear, roadside fastener. If removal is required, re-install exhaust pipe after completion of shim and mounting hardware installation.

Ensure that the exhaust pipe temperature has cooled down prior to handling.

9. Upon completion of installing the four shims and mounting hardware, lower the jack removing all stress from the engine. Remove the jack from under the coach.
10. Torque 19-3-480 to 285–385 lbs.-ft. Torque 19-3-479 to 451 –546 lbs.-ft.

NOTICE

Procedure Steps 11. to 17. are performed with the coach on a lift. Position jackstands at the front and rear frame support points, according to Figure 2, to ensure that the coach is securely supported before attempting work underneath the coach. Support the tag axle.

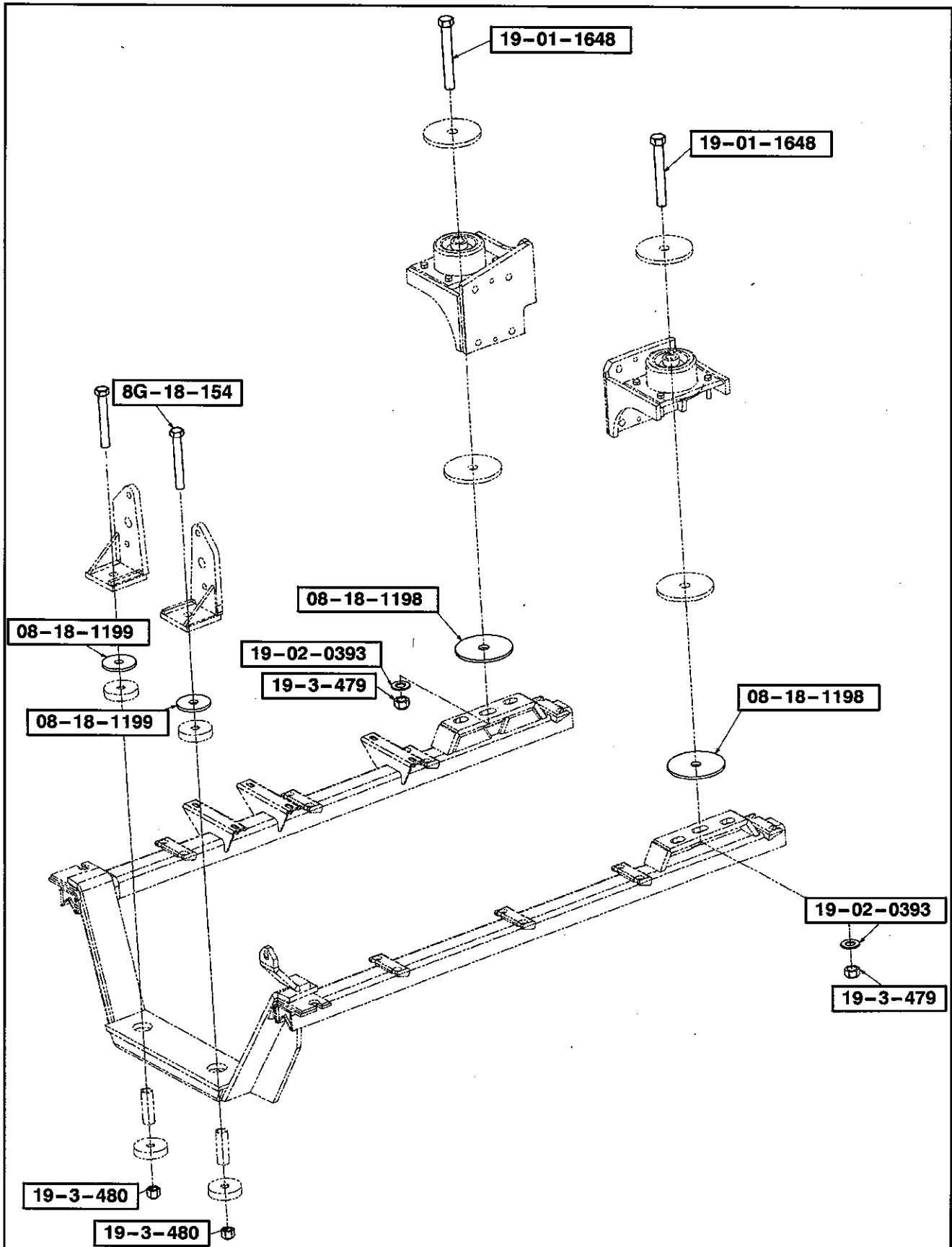

Figure 1.

NOTICE

Steps 11. to 17. will be performed with the coach on a lift.

NOTICE

PRIOR TO lifting the coach, exhaust all coach air. Locate the tag axle dump valves in the curbside, rear service compartment. Turn the tag axle dump valves to the OFF (vertical) position, completely dumping the tag axle air springs.

Dump the air from the tag axle suspension and raise coach to desired height. Position jackstands at the front and rear frame support points, according to Figure 2, to ensure that the coach is securely supported before attempting work underneath the coach.

Support the tag axle.

REFER TO MANUAL

Refer to Lifting and Towing, in the MCI Maintenance Manual, for the basic rules, procedures and safety precautions that must be followed before a coach is to be lifted.

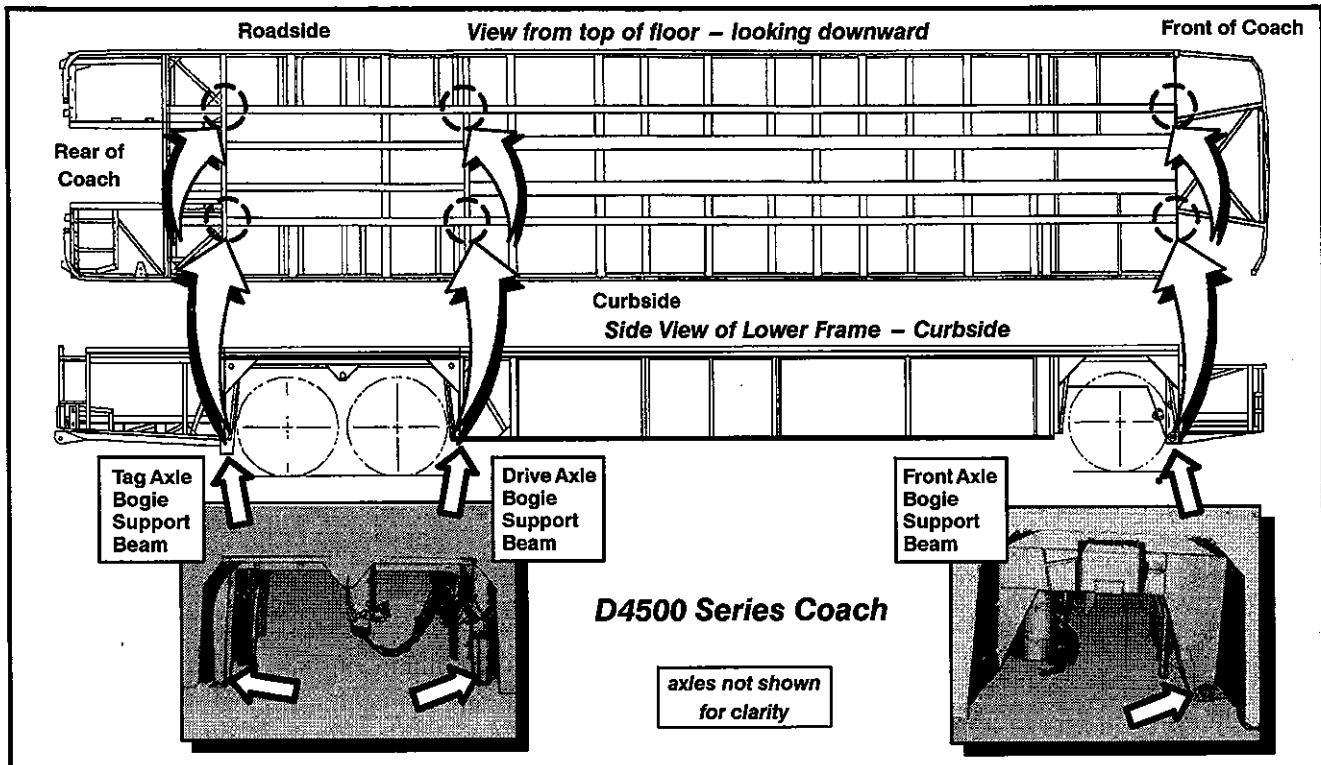

Figure 2. – D4500 Under Frame Jackstand Support Points

11. Locate the four existing rubber bumpers on the tag axle suspension assembly (Figures 3 and 5).

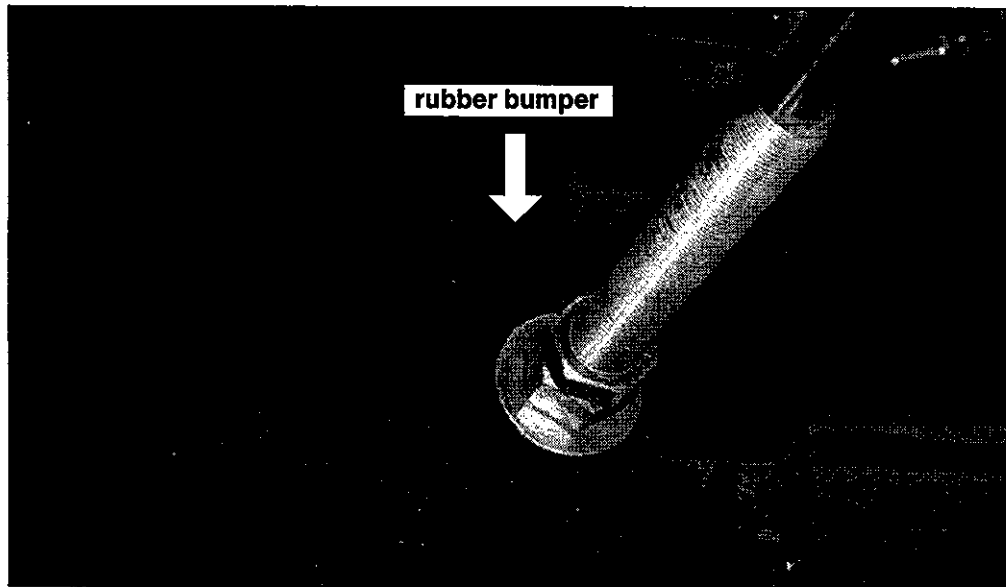

Figure 3. Reference photo.

NOTICE

Remove and replace ONE bumper assembly at a time.

12. Remove existing bumper assembly and discard. DO NOT re-use existing bumper.

NOTICE

If necessary, use a reciprocating saw to cut the threads on the existing bumper assembly, to aid in removal.

Assemble with Never-seize.

13. Disk sand the mounting surface in preparation of good reassembly.
14. Install the new rubber bumper (p/n 12G-1-5) and bumper block spacer (p/n 12R-1-6) (Detail B / Figure 5).

NOTICE

Always use new fastener hardware when installing / re-installing suspension components on the front, drive and tag suspension systems.

CAUTION

DO NOT attempt repair or removal of the air spring unless the air is completely released from the spring. Use caution when working near an inflated air spring.

- 15. Remove and discard the plate assembly and mounting hardware (Figures 4 and 5).

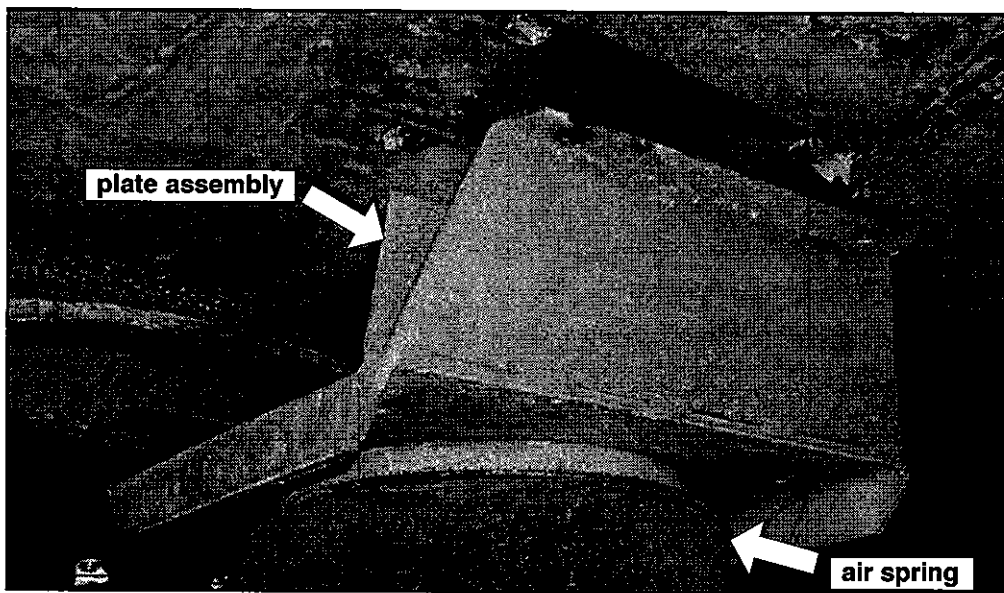

Figure 4. Reference photo.

- 16. Install the new plate assembly (p/n 12-04-1160) and spacer (p/n 12-04-1083) in the locations shown in Figure 5., using the new plate assembly mounting hardware provided in the Parts list. Torque nut (p/n 19-3-314) to 18–22 ft.-lbs.
- 17. Align and position the spacer (p/n 12-04-1074) in the location shown in Figure 5.

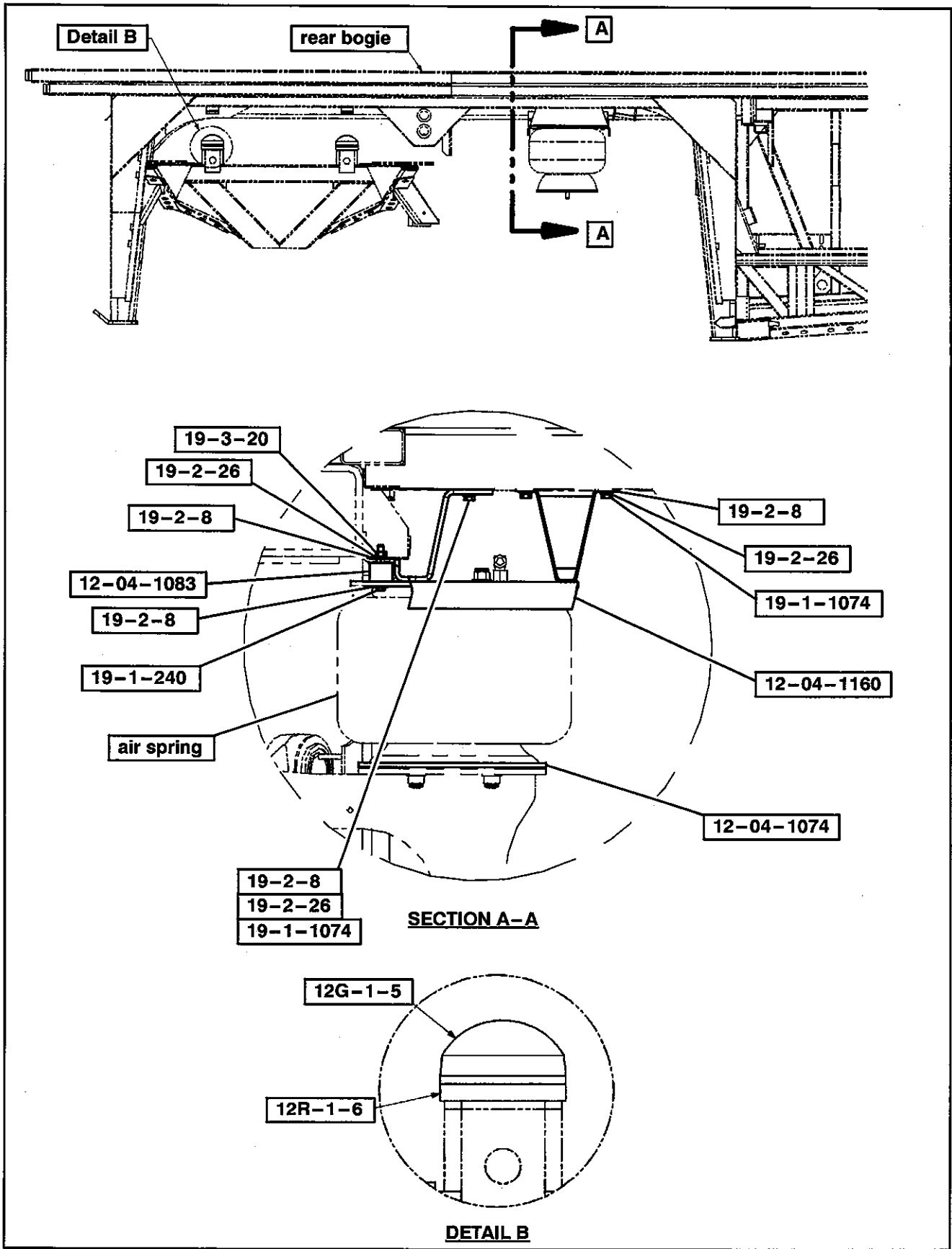

Figure 5.

18. After the coach has been lowered to the ground and lifts removed, return the tag axle dump valves to the ON (horizontal) position. Close the curbside, rear service department door.

Procedure complete.

Mail or fax the completed warranty claim form to MCI's warranty department, or photocopy and mail it to:

MCI Fleet Support
Attn: Warranty Department
7001 Universal Coach Drive
Louisville, KY 40258
Fax Number 1-800-360-8886

to receive credit for the hours used to complete this task. Contact the MCI Fleet Support Technical Center at 1-800-241-2947 for any further information.

Field Change Program Conditions:

The parts required for this change will be supplied without charge.

A labor allowance of 5.5 hours will be granted, for the procedure of installing the specified part(s) in this bulletin on D4500 / D4505 model coaches.

Only 1 claim can be filed against the coach VIN, SB 277, SB 277B or SB 277C.

This labor allowance will be credited to your MCI Fleet Support Parts Account on receipt of a "Warranty Claim Form" as detailed in your Owner Warranty manual.

Motor Coach apologizes for any inconvenience resulting from this campaign, but urges you to implement this change as soon as possible.

Sincerely,

Motor Coach Industries
U.S. and Canadian Service Departments.



Service Bulletin No. 320

MODEL D4500 / D4505 Series Coaches	TYPE Field Change Program	SECTION/GROUP 14-Drive Shaft	DATE Feb. 24, 2009
SUBJECT TAG AXLE / DRIVE SHAFT INTERFERENCE – DETROIT DIESEL SERIES 60 ENGINE AND ZF TRANSMISSION			
CONDITIONS IN CONJUNCTION WITH THIS CAMPAIGN, COMPLETION OF FCP 276B AND FCP 277C IS REQUIRED ON COACHES IDENTIFIED ON THOSE FCP'S.			

Ref. NHTSA Recall No.: 09V-041

Ref. TC Recall No.: 09-052

Customer Complaint:

Customers may experience interference between the drive shaft U-joint bearing cap bolts and the tag axle center beam assembly. This can occur when,

- The coach auxiliary air system is depleted of air, the tag axle is forced up into the air bag bump stops and the coach is put in motion prior to this system reaching its minimum acceptable operational air pressure, and/or
- Through curbing of the axle and the tag axle is forced up into the air bag bump stops, and/or
- The coach is in low ride position and the tag axle is forced up into the air bag bump stops by uneven ground.

Cause:

The interference is due to limited clearance between the drive shaft U-joint bearing cap bolts and the tag axle center beam. This can take place when the coach is positioned such that the tag axle air springs are fully collapsed and the weight of the coach is supported by the air spring internal bumpers. Under these circumstances, interference between the bearing cap bolts and the axle center beam assembly is possible. This situation can be found on certain D4500 / D4505 coaches equipped with a Detroit Diesel Series 60 engine and a ZF transmission.

Corrective Action:

MCI strongly encourages customers operating coaches equipped with a Detroit Diesel Series 60 engine and a ZF transmission to install the parts referenced in this bulletin to reduce the swing diameter of the driveshaft and increase the clearance, eliminating any possible interference.

As a result, MCI advises that owners of D4500 / D4505 model coaches between the range of, and including, unit numbers 56555 to 56577, 56773 to 56775, 57046, 57147 to 57166, 57203 and 57204, 57340, 57345 to 57379, 57540 to 57549, 58311 to 58313, 58337, 58338, 58500, 58582, 58583 implement the specified steps in this procedure.

Parts

<u>Qty.</u>	<u>Old P/N</u>	<u>New P/N</u>	<u>Description</u>
1		26-14-0001	Kit, SPL250 Driveshaft Retrofit <i>Kit Contents Are:</i>
1		02-03-1028	Seal, Pinion, Oil, Drive
1		13-01-1087	Flange, Output, ZF
1		13-01-1088	Seal, Output Shaft, ZF
1		13-01-1089	O-Ring, Yoke, Retaining Plate, ZF
1		13-01-1090	Plate, Yoke Retaining, ZF
2		13-01-1091	Bolt, Hex, M12x60, Yoke, Retaining Plate
1		14-01-1025	End Yoke Assembly, 1/2 Round, SPL250
1		14-01-1026	Driveshaft, SPL250, S60, ZF
2		14-01-1027	Yoke Flange, 1/2 Round, SPL250
1		14-01-1028	Kit, Strap / Bolt, SPL250
4		14-01-1029	Capscrew, Hex Head, M14x1.5x50
4		19-03-0634	Nut, Hex, M14x1.5
a/r		21-7212-26	Loctite 262
a/r		21-7512-5	Grease, Heavy
1		13-01-1097	Decal, ZF Trans. Label, Pre-2007 EPA (applicable for units 56555-57549) OR,
1		13-01-1096	Decal, ZF Trans. Label, 2007 EPA (applicable for units 58311-58583)

Service Procedure:

General notes

Read this entire procedure before beginning work.

Use Safe Shop Practices At All Times.

1. Turn the main battery disconnect switch to the " OFF " position.

NOTICE

PRIOR TO lifting the coach, exhaust all coach air. Locate the tag axle dump valves in the curbside, rear service compartment. Turn the tag axle dump valves to the OFF (vertical) position, completely dumping the tag axle air springs.

Dump the air from the tag axle suspension and raise coach to desired height. Position jackstands at the front and rear frame support points, according to Figure 1, to ensure that the coach is securely supported before attempting work underneath the coach.

Support the tag axle.

REFER TO MANUAL

Refer to Lifting and Towing, in the MCI Maintenance Manual, for the basic rules, procedures and safety precautions that must be followed before a coach is to be lifted.

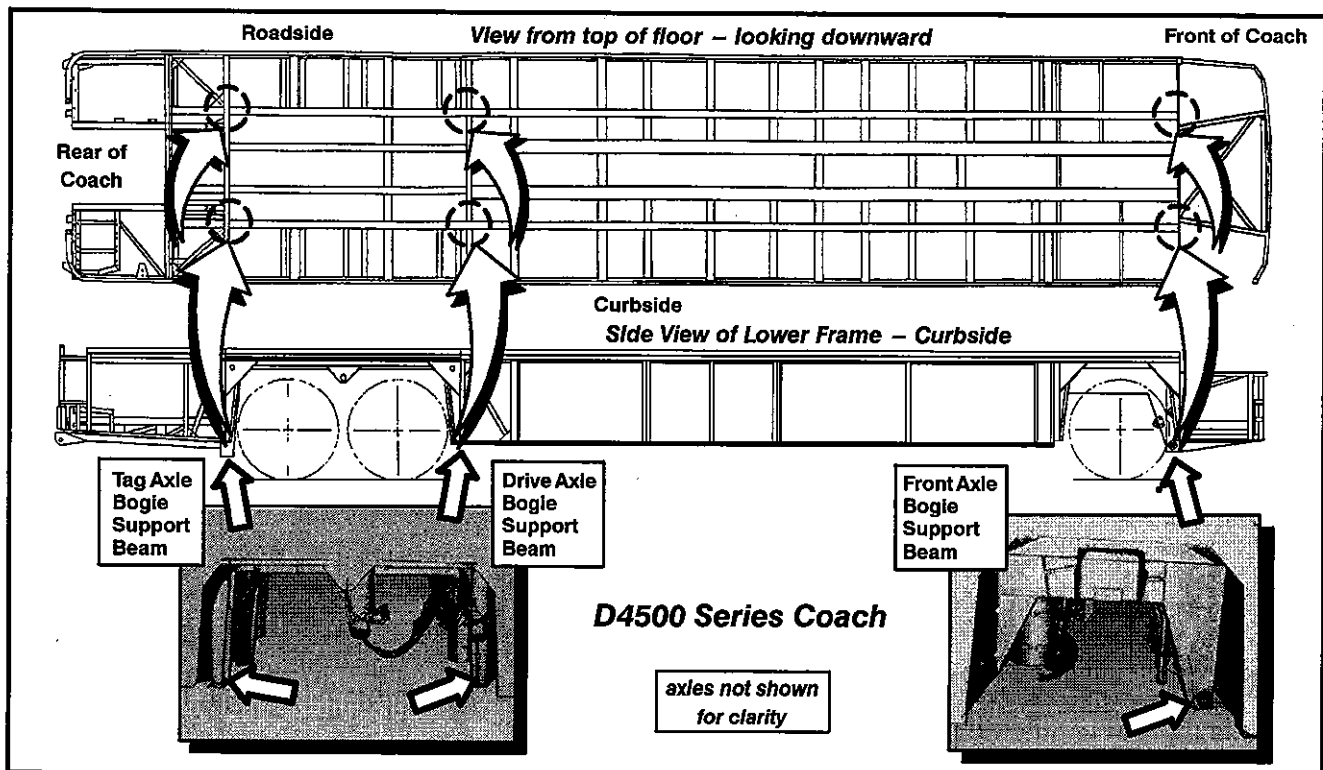

Figure 1. - D4500 Under Frame Jackstand Support Points



REFER TO MANUAL

Refer to Section 14 / Driveshaft, in the MCI D Series Maintenance Manual, in conjunction with this procedure.

2. Remove and retain the driveshaft guard.
3. Remove the half-round straps at the differential yoke.
4. Remove the driveshaft from the differential yoke by collapsing the slip-joint.
5. Remove the half-round straps at the transmission yoke.
6. Remove and discard the driveshaft from the coach.
7. Drain the transmission fluid into a clean, suitably-sized container. Place container aside to be re-used later.
8. Drain the drive axle oil into a clean, suitably-sized container. Place container aside to be re-used later.
9. Remove and discard the existing transmission end yoke and output seal.
10. Remove and discard the existing the drive axle end yoke and pinion seal. Retain the pinion nut and washer to be re-installed at a later step in this procedure.
11. Using tool no. 20-710, install the drive axle pinion seal (p/n 02-03-1028) (refer to Figure 2).
12. Lubricate the seal mounting surface of the end yoke assembly (p/n 14-01-1025) and install on the output shaft taking care not to damage the seal. Install the washer and pinion nut removed in Step 10. and torque the pinion nut to 1000-1230 lb-ft.
13. Using an appropriate size seal installation tool, install the output seal (p/n 13-01-1088) into the transmission. Take care not to damage the seal.
14. Lubricate the seal contact surface on the output flange (p/n 13-01-1087) and install in transmission using plate (p/n 13-01-1091) , o-ring (p/n 13-01-1089) and bolts (p/n 13-01-1091). Apply Loctite to bolts and torque to 80-95 lb-ft.
15. Using bolts (p/n 14-01-1029) and nuts (p/n 19-03-0634), install flange yoke (p/n 14-01-1027) to output flange. Torque to 115-125 ft-lbs.

NOTICE

Install the slip joint end towards axle.

16. Using the straps and bolts kit (p/n 14-01-1028), install the driveshaft (p/n 14-01-1026) being sure to install the slip yoke end towards the drive axle. Torque the bearing cap bolts to 115 - 125 lb-ft.
17. Re-fill the drive axle with oil saved in Step 2. Top-up level as required.
18. Re-fill the transmission with fluid saved in Step 2. Top-up level as required.
19. Using grease (p/n 21-7512-5), grease driveshaft u-joint.
20. Reinstall the driveshaft guard and fasteners removed in Step 2. Torque fasteners to 16-28 lb-ft.

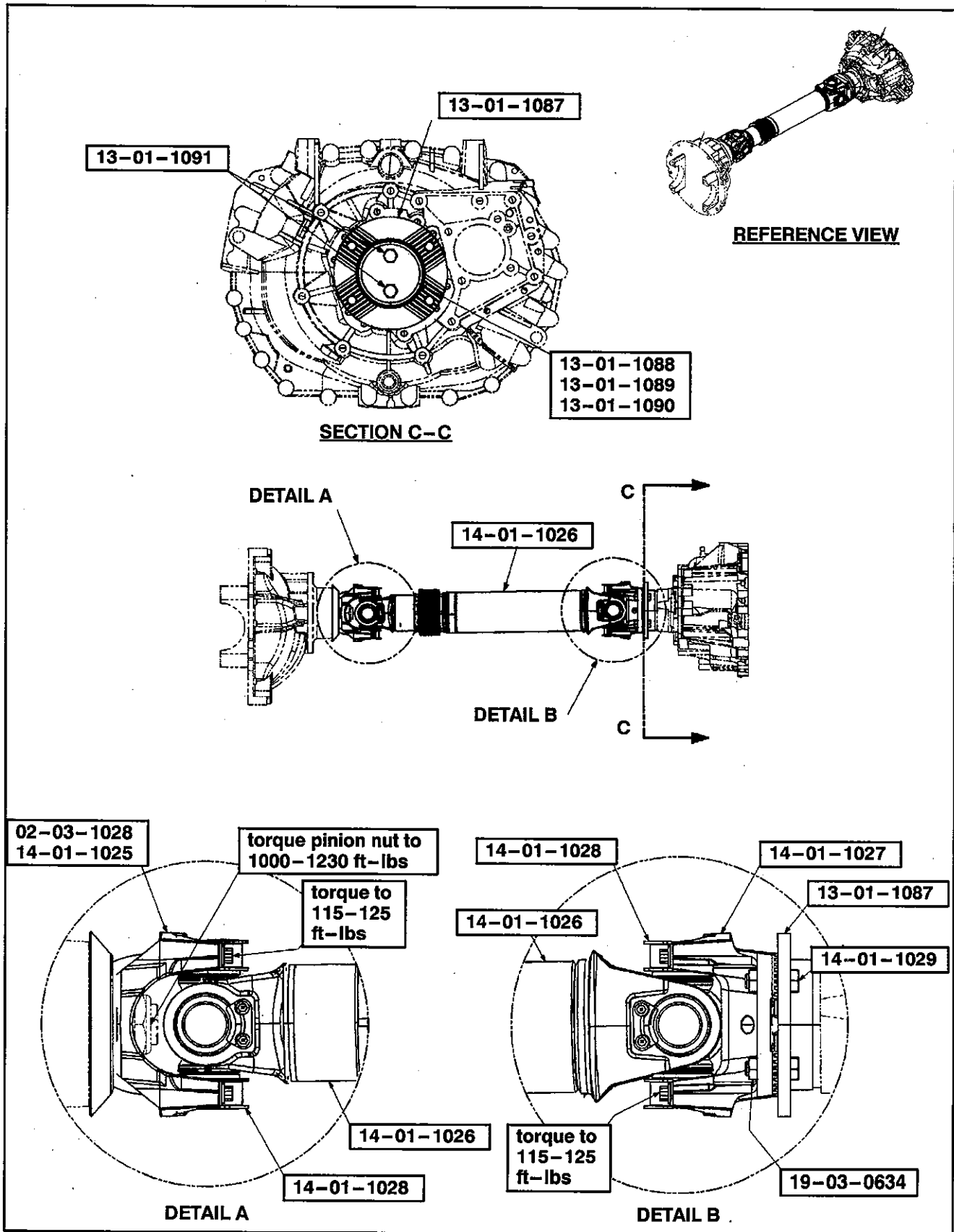

Figure 2.

- 21. Locate the blue w/ silver serial number plate on the curbside of the transmission (refer to Figures 5 and 6).
- 22. Using a clean cloth, remove all dirt from the face of the transmission serial number plate.
- 23. Using a 50/50 mixture of isopropyl alcohol and water, clean the face of the serial number plate.

NOTICE

Allow enough time for mixture to flash off.

- 24. Carefully align and apply the applicable decal, p/n 13-01-1096 **or** 13-01-1097 over the existing transmission serial number plate (refer to Figure 5). Discard other decal.

NOTICE

Decal, p/n 13-01-1096, is applicable for unit numbers 58311–58583 (refer to Figure 3).

Decal, p/n 13-01-1097, is applicable for unit numbers 56555–57549 (refer to Figure 4).

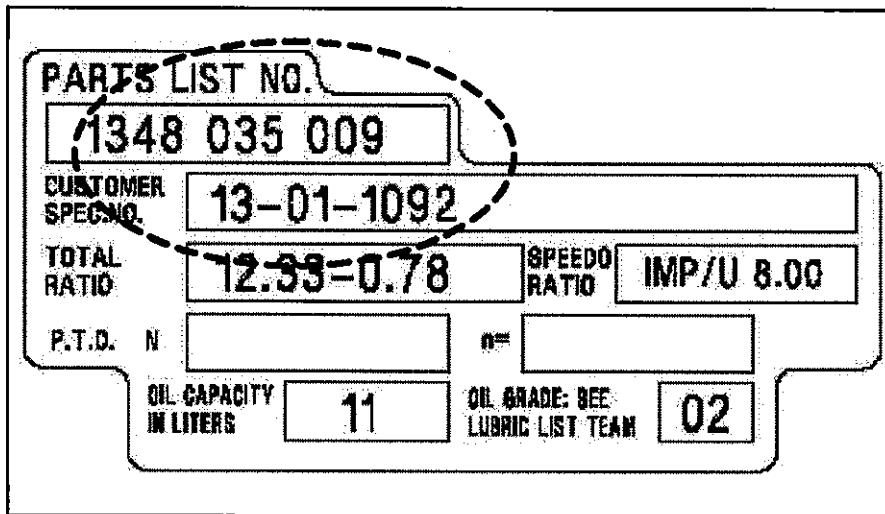

Figure 3. Decal, p/n 13-01-1096, used on 2007 EPA compliant coaches.

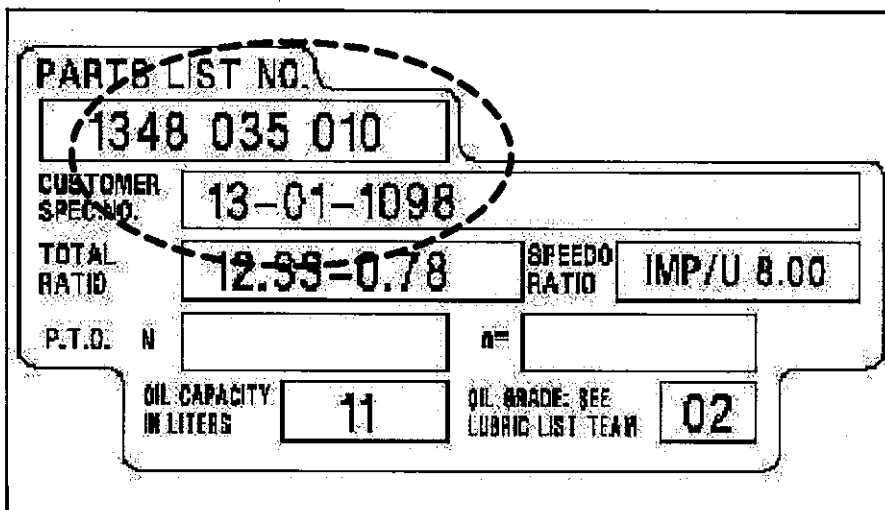

Figure 4. Decal, p/n 13-01-1097, used on pre-2007 coaches.

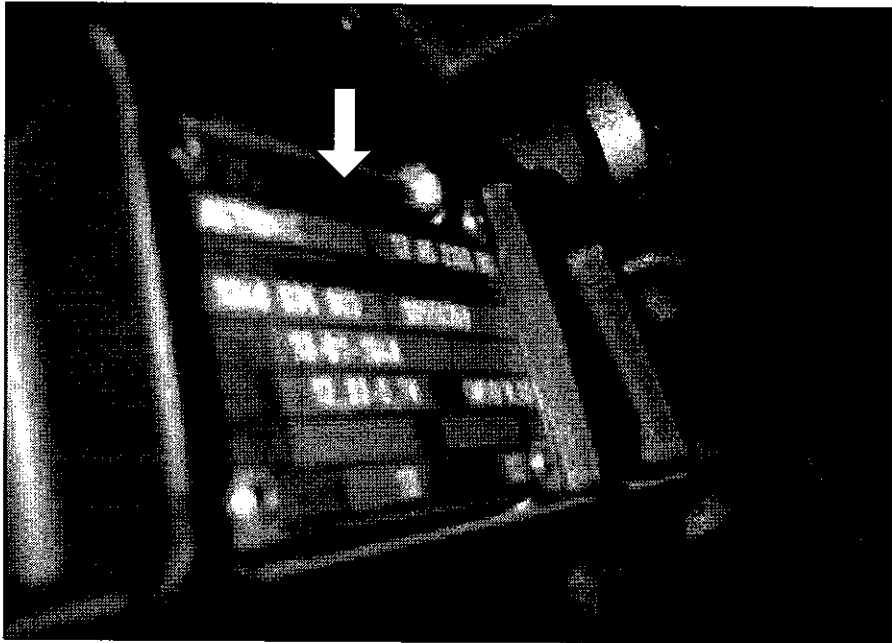

Figure 5. ZF transmission serial number plate.

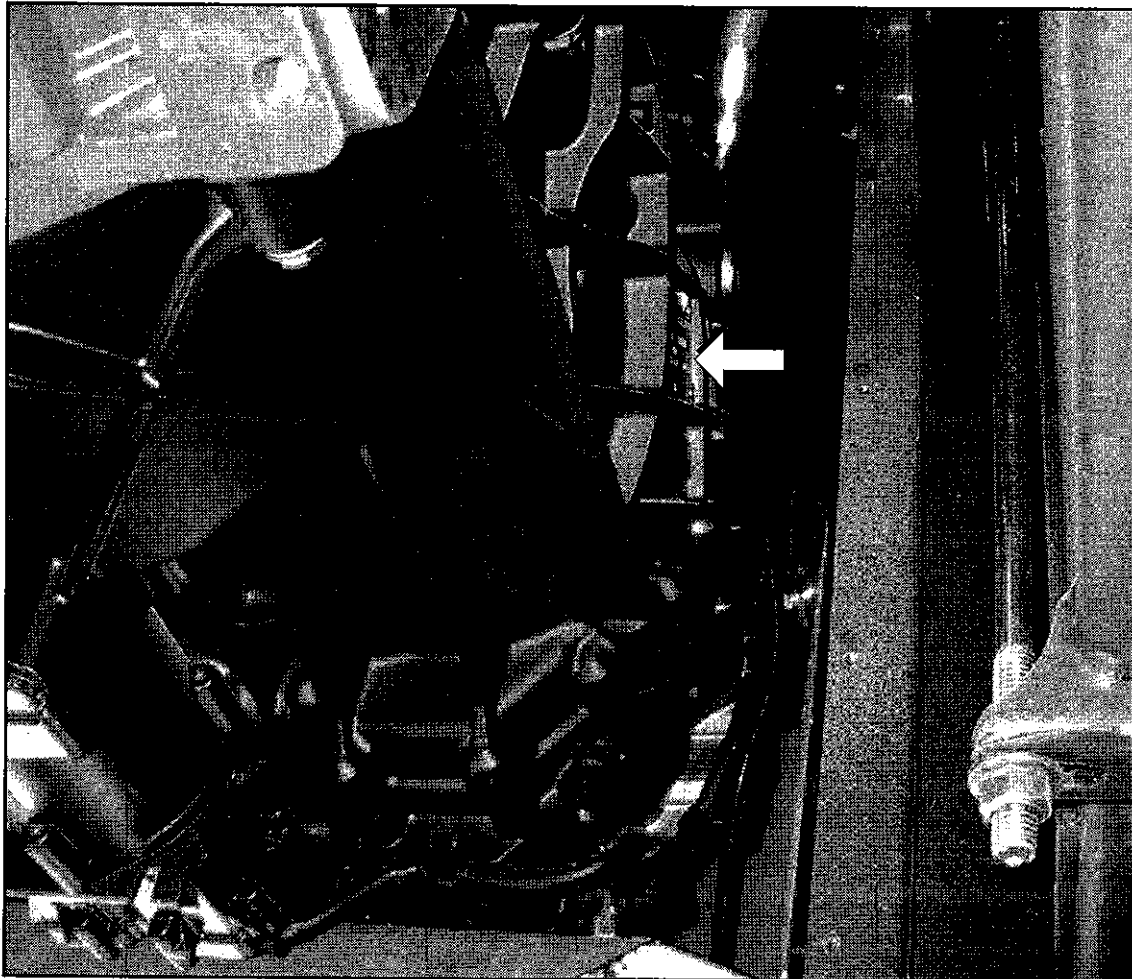

Figure 6. Location of ZF transmission serial number plate, on curbside of coach.

25. After the coach has been lowered to the ground and lifts removed, return the tag axle dump valves to the ON (horizontal) position. Close the curbside, rear service department door.
26. After 50 to 100 miles of operation, check transmission output shaft seal and drive axle input seal for leaks. Replace if necessary.

Procedure complete.

Mail or fax the completed warranty claim form to MCI's warranty department, or photocopy and mail it to:

MCI Fleet Support
Attn: Warranty Department
7001 Universal Coach Drive
Louisville, KY 40258
Fax Number 1-800-360-8886

to receive credit for the hours used to complete this task. Contact the MCI Fleet Support Technical Center at 1-800-241-2947 for any further information.

Field Change Program Conditions:

The parts required for this change will be supplied without charge.

A labor allowance of 5.0 hours will be granted, for the procedure of installing the specified part(s) in this bulletin on D4500 / D4505 model coaches.

This labor allowance will be credited to your MCI Fleet Support Parts Account on receipt of a "Warranty Claim Form" as detailed in your Owner Warranty manual.

Motor Coach apologizes for any inconvenience resulting from this campaign, but urges you to implement this change as soon as possible.

Sincerely,

Motor Coach Industries
U.S. and Canadian Service Departments.