



February 5, 2009

Mr. Daniel Smith
Associate Administrator for Enforcement
National Highway Traffic Safety Administration
1200 New Jersey Ave. S.W.
Washington, D.C. 20590

Dear Mr. Smith:

Reference: NHTSA Identification Number 09V-005

Enclosed are representative copies of communications relating to the 2008 and 2009 model year vehicles involved in the referenced recall. Chrysler expects to notify dealers during the week of February 9, 2009 and to begin owner notification during the week of February 16, 2009. The exact number of manufactured vehicles in the recall is 32,782.

This completes Chrysler's package of information for this recall as required by the Defects Report Regulation.

Sincerely,

A handwritten signature in cursive script, appearing to read "Lawrence J. Sak".

Lawrence J. Sak
Vehicle Compliance and Safety Affairs

Enclosure: Dealer and Owner Letter for Recall H36

cc: K.C. DeMeter



February 2009

Dealer Service Instructions for:

Safety Recall H36

Steering Drag Link inner Joint and Damper Bracket

Models

2008-2009 (DH / D1) Dodge Truck

NOTE: This recall applies only to the above vehicles equipped with four wheel drive (sales code 5I4) built from February 19, 2008 through October 30, 2008 (MDH 021910 through 103006).

2008-2009 (DC) Dodge Truck

NOTE: This recall applies only to the above vehicles built from February 19, 2008 through October 30, 2008 (MDH 021910 through 103006).

IMPORTANT: Many of the vehicles within the above build period have already been inspected or repaired and, therefore, have been excluded from this recall.

IMPORTANT: Some of the involved vehicles may be in dealer new vehicle inventory. Federal law requires you to complete this recall service on these vehicles before retail delivery. Dealers should also consider this requirement to apply to used vehicle inventory and should perform this recall on vehicles in for service. Involved vehicles can be determined by using the VIP inquiry process.

Subject

The steering drag link inner joint on about 32,700 of the above vehicles may fracture under certain driving conditions. This could result in a loss of steering control and cause a crash without warning.

Also the steering damper bracket at the tie rod tube may loosen. This could allow the bracket to slide on the tube and may cause increased vehicle turning radius.

Repair

The drag link inner joint must be replaced and the steering damper bracket must be inspected and replaced if required.

Alternate Transportation

Dealers should attempt to minimize customer inconvenience by placing the owner in a loaner vehicle if inspection determines that the steering damper bracket is required and the vehicle must be held overnight.

Parts Information

Part Number Description
CBD1H361 Damper Bracket Package

Each package contains the following components:

<u>Quantity</u>	<u>Description</u>
1	Bracket, Damper
2	U-Bolts
4	Nuts
1	Carriage bolt

Each dealer to whom vehicles in the recall were assigned will receive enough Damper Bracket Packages to service about 20% of those vehicles.

Part Number Description
CBFAH362 Drag Link Inner Joint Package

Each package contains the following components:

<u>Quantity</u>	<u>Description</u>
1	Joint, Drag Link Inner
1	Nut, Drag Link Inner Joint-to-Pitman Arm Retaining

Each dealer to whom vehicles in the recall were assigned will receive enough Drag Link Inner Joint Packages to service about 20% of those vehicles.

Service Procedure

1. Lift the vehicle on an appropriate hoist.
2. Inspect the steering damper bracket mounting nuts by putting a 13 mm box-end wrench onto the nut (Figure 1):
 - If a **13 mm wrench fits** the steering damper bracket mounting nuts, the bracket and fasteners **must be replaced**. Continue with Step 3 of this procedure.
 - If a **13 mm wrench does not fit** the steering damper bracket mounting nuts, the bracket **does not require replacement**. Continue with Step 4 of this procedure.

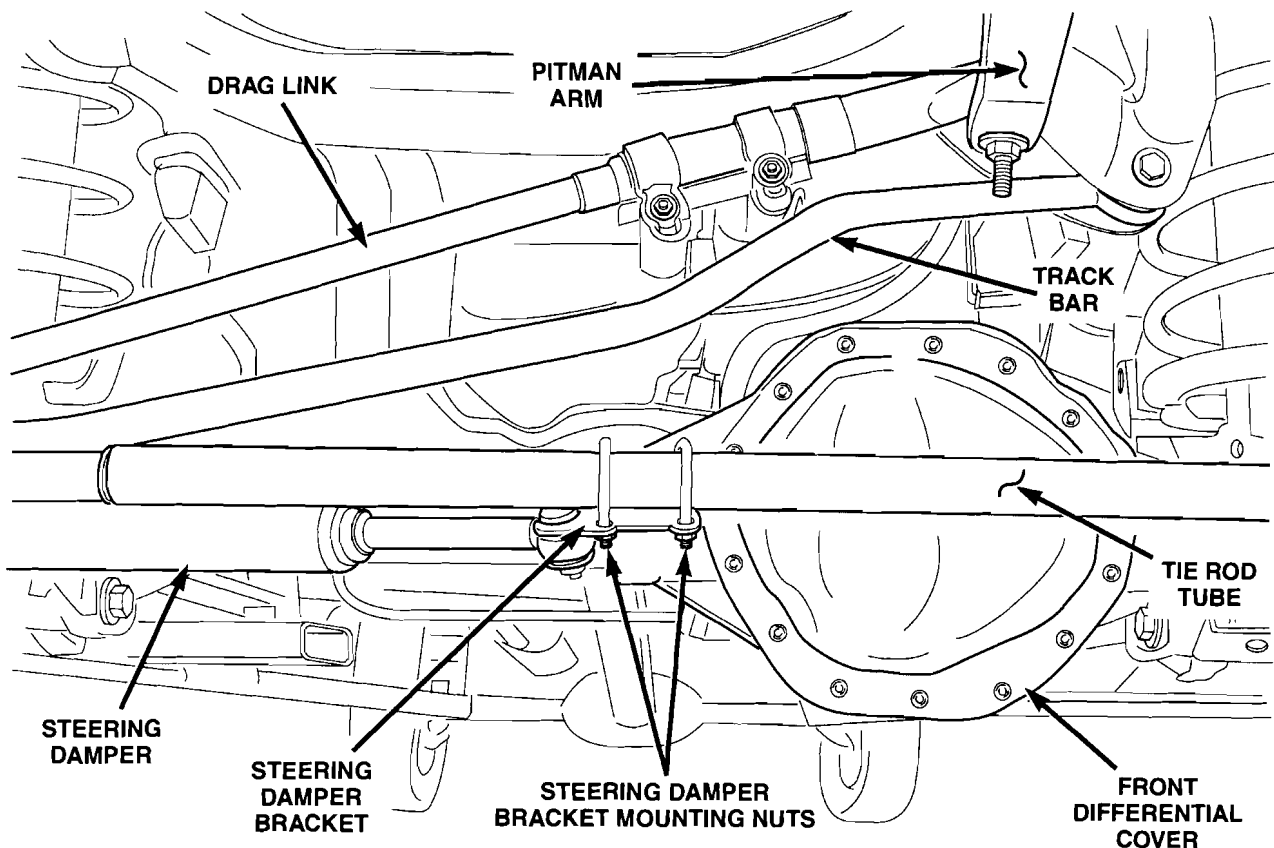

Figure 1

Service Procedure (Continued)

3. Replace the steering damper bracket and fasteners using the following procedure:

- a. Remove and save the steering damper-to-damper bracket mounting nut (Figure 2).
- b. Disconnect the steering damper from the steering damper bracket.
- c. Remove and discard the four steering bracket nuts, two u-bolts and the bracket (Figure 2).

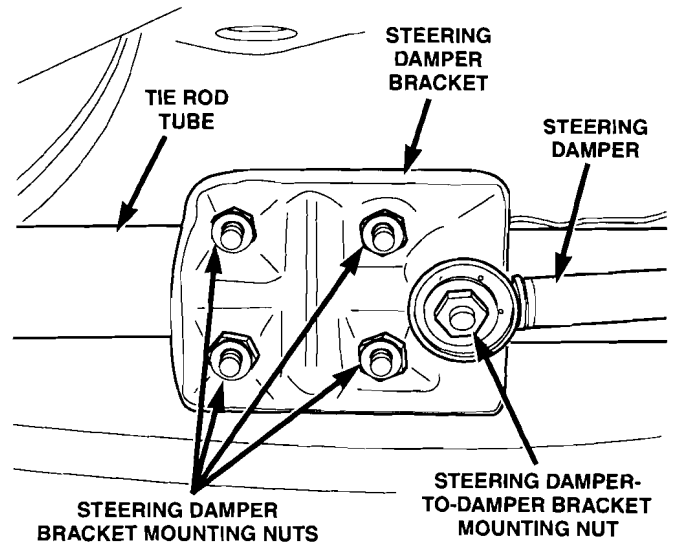

Figure 2

- d. Place the new steering damper carriage bolt through the square hole in the new bracket.
- e. Place the new steering damper bracket assembly onto the tie rod tube at the flat spot area on the tube and install the new u-bolts and nuts. Lightly snug the nuts to hold the steering damper bracket in position.
- f. Center the new steering damper bracket on the flattened area of the tie rod tube.
- g. Evenly tighten the four steering damper bracket u-bolt nuts to 25 ft. lbs. (34 N·m). Then tighten the four u-bolt nuts to 45 ft. lbs. (61 N·m).
- h. Connect the steering damper to the steering damper carriage bolt.
- i. Install the steering damper mounting nut and tighten to 75 ft. lbs. (100 N·m).
- j. Continue with Step 4 of this procedure.

Service Procedure (Continued)

4. Replace the drag link inner joint using the following procedure:
 - a. Loosen both drag link adjuster sleeve clamp nuts (Figure 3).
 - b. Remove and discard the drag link inner joint-to-pitman arm retaining nut (Figure 3).

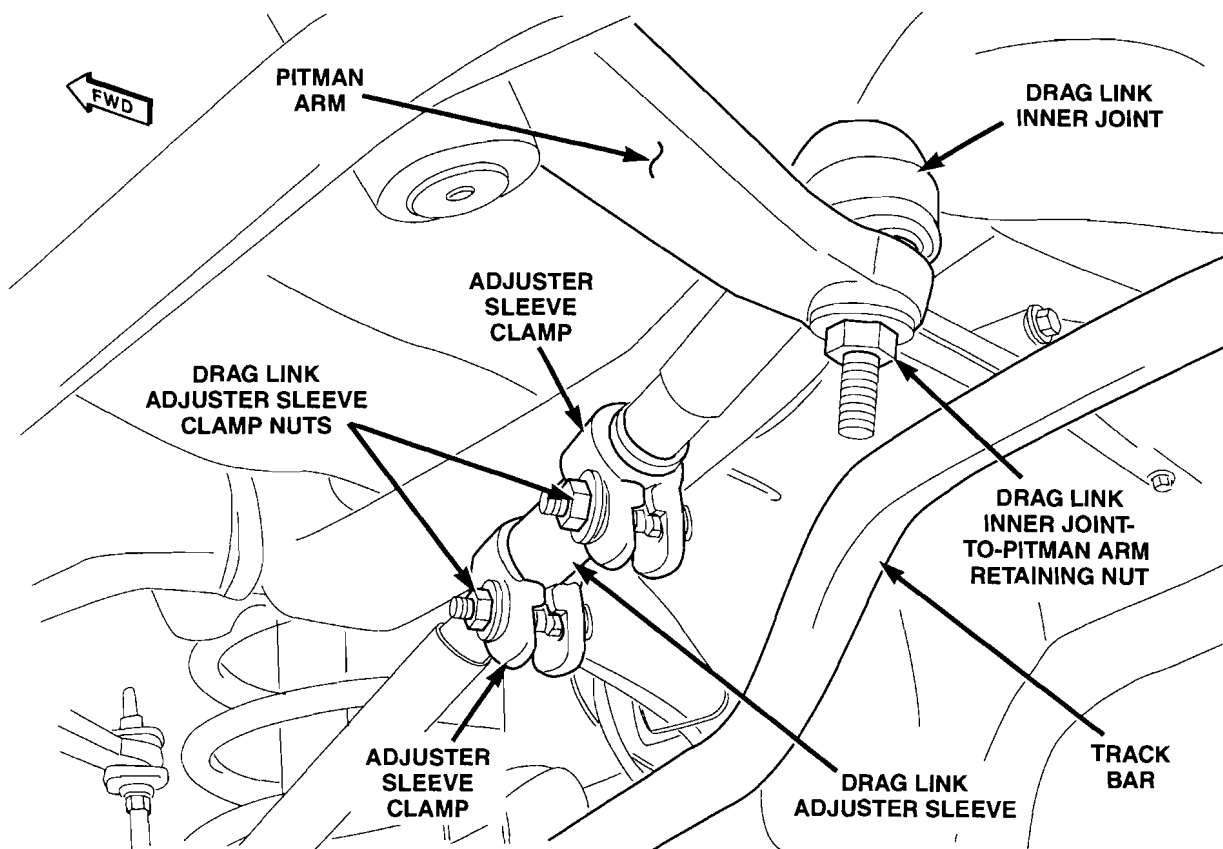

Figure 3

Service Procedure (Continued)

c. Using special tool C-4150A, separate the steering drag link inner joint from the pitman arm (Figure 4).

d. While counting the number of turns, unscrew the steering drag link inner joint from the drag link adjuster sleeve (right handed threads) (Figure 5).

CAUTION: Do not allow the drag link adjuster sleeve to turn while unscrewing the drag link inner joint.

e. Screw in the new steering drag link inner joint into the drag link adjuster sleeve the same number of turns counted in step 4d. of this procedure.

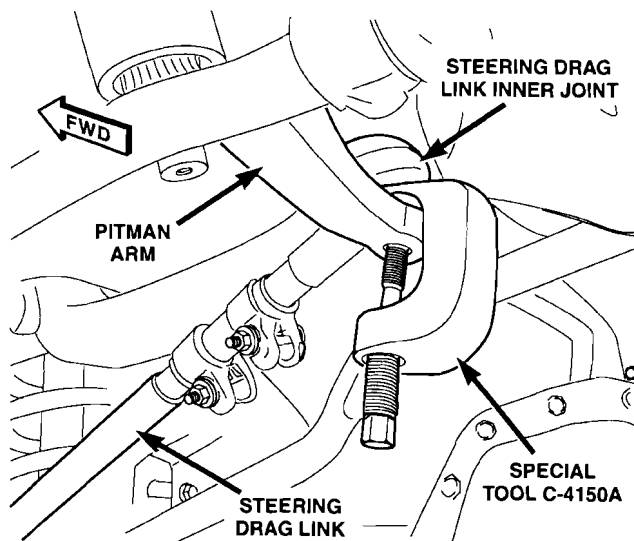

Figure 4

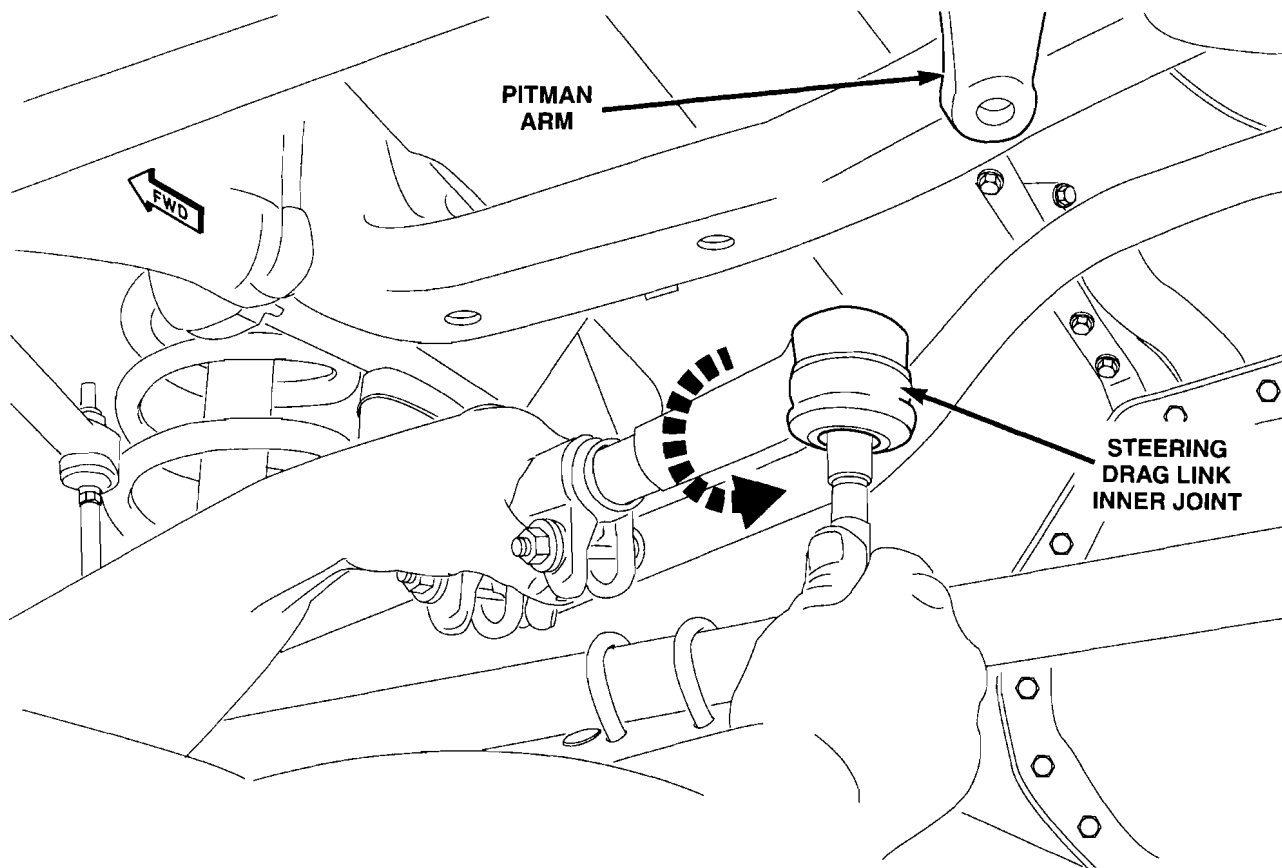

Figure 5

Service Procedure (Continued)

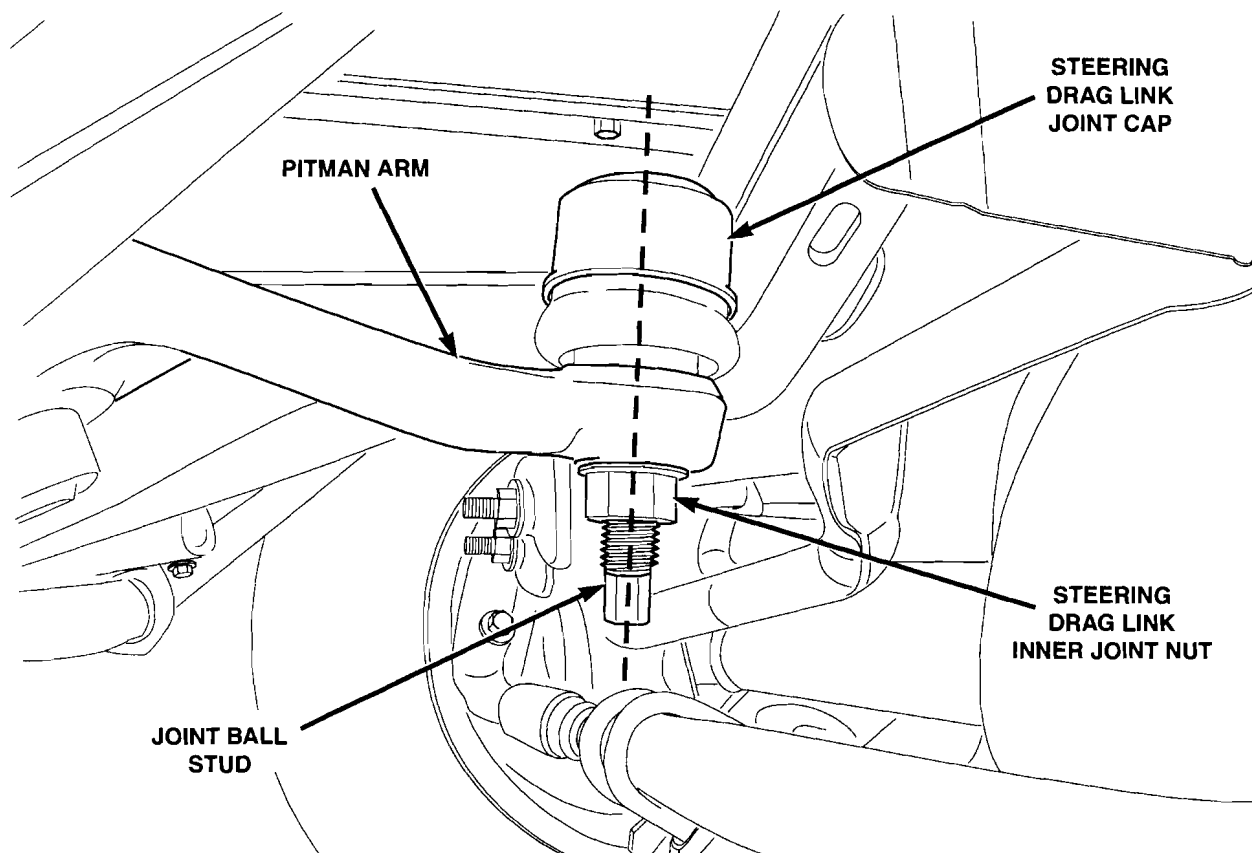

Figure 6

- f. Connect the new steering drag link inner joint to the pitman arm.
- g. Install the new steering drag link inner joint nut and tighten the nut to 100 ft. lbs. (135 N·m).
- h. With the wheels in the straight ahead position, make sure that both inner and outer steering drag link joint caps are centered over the joint ball stud (Figure 6).

CAUTION: Failure to center the drag link inner and outer joint caps over the joint ball studs before tightening the drag link adjuster sleeve clamps could cause joint failure.

- i. Tighten the drag link adjuster sleeve clamp nuts to 45 ft. lbs. (61 N·m).

CAUTION: The drag link adjuster sleeve clamp tabs must be pointing downward before tightening (as shown in Figure 3).

Service Procedure (Continued)

5. Lower the vehicle from the hoist.
6. Drive the vehicle to verify that the steering wheel is straight.
 - If the steering wheel is turned to the left, **shorten** the drag link at the adjuster sleeve located on the drag link.
 - If the steering wheel is turned to the right, **lengthen** the drag link at the adjuster sleeve located on the drag link.
7. Repeat Step 6 until steering wheel is straight.

Completion Reporting and Reimbursement

Claims for vehicles that have been serviced must be submitted on the DealerCONNECT Claim Entry Screen located on the Service tab. Claims submitted will be used by Chrysler to record recall service completions and provide dealer payments.

Use one of the following labor operation numbers and time allowances:

	<u>Labor Operation Number</u>	<u>Time Allowance</u>
Inspect steering damper bracket and replace the steering drag link inner joint	19-H3-61-82	0.3 hours
Inspect and replace steering damper bracket and the steering drag link inner joint	19-H3-61-83	0.5 hours

Related Operation

Center steering wheel	19-H3-61-50	0.1 hours
-----------------------	-------------	-----------

Add the cost of the recall parts package plus applicable dealer allowance to your claim.

NOTE: See the Warranty Administration Manual, Recall Claim Processing Section, for complete recall claim processing instructions.

Dealer Notification

To view this notification on DealerCONNECT, select “Global Recall System” on the Service tab, then click on the description of this notification.

Owner Notification and Service Scheduling

All involved vehicle owners known to Chrysler are being notified of the service requirement by first class mail. They are requested to schedule appointments for this service with their dealers. A generic copy of the owner letter is attached.

Enclosed with each owner letter is an Owner Notification postcard to allow owners to update our records if applicable.

Vehicle Lists, Global Recall System, VIP and Dealer Follow Up

All involved vehicles have been entered into the DealerCONNECT Global Recall System (GRS) and Vehicle Information Plus (VIP) for dealer inquiry as needed.

GRS provides involved dealers with an updated VIN list of their incomplete vehicles. The owner's name, address and phone number are listed if known. Completed vehicles are removed from GRS within several days of repair claim submission.

To use this system, click on the “**Service**” tab and then click on “**Global Recall System.**” Your dealer's VIN list for each recall displayed can be sorted by: those vehicles that were unsold at recall launch, those with a phone number, city, zip code, or VIN sequence.

Dealers must perform this repair on all unsold vehicles before retail delivery. Dealers should also use the VIN list to follow up with all owners to schedule appointments for this repair.

Recall VIN lists may contain confidential, restricted owner name and address information that was obtained from the Department of Motor Vehicles of various states. Use of this information is permitted for this recall only and is strictly prohibited from all other use.

Additional Information

If you have any questions or need assistance in completing this action, please contact your Service and Parts District Manager.

Customer Services Field Operations
Chrysler