



November 12, 2009

Mr. Daniel Smith
Associate Administrator for Enforcement
National Highway Traffic Safety Administration
1200 New Jersey Ave. S.W.
Washington, D.C. 20590



Dear Mr. Smith:

Reference: NHTSA Identification Number 09E-044

Enclosed are representative copies of communications relating to the 2007 and 2008 model year vehicles involved in the referenced recall. Chrysler expects to notify dealers during the week of November 16, 2009 and to begin owner notification during the week of November 23, 2009. The exact number of manufactured vehicles in the recall is 308.

This completes Chrysler's package of information for this recall as required by the Defects Report Regulation.

Sincerely,

A handwritten signature in blue ink, appearing to read "David D. Dillon".

For: David D. Dillon
Vehicle Compliance and Safety Affairs

Enclosure: Dealer and Owner Letter for Recall J24

cc: K.C. DeMeter



November 2009

Dealer Service Instructions for:

Safety Recall J24 - MOPAR Tow Bar

Models

2007-2008 (JK) Jeep® Wrangler

NOTE: This recall applies only to the above vehicles built through June 2, 2008 (MDH 060223).

IMPORTANT: Some of the involved vehicles may be in dealer vehicle inventory. Federal law requires you to complete this recall service on these vehicles before retail delivery. Dealers should also consider this requirement to apply to used vehicle inventory and should perform this recall on vehicles in for service. Involved vehicles can be determined by using the VIP inquiry process.

Subject

The MOPAR brand tow bar purchased for use, on about 315 of the above vehicles, may allow the towed vehicle to become detached from the tow vehicle. This can result in a crash without warning.

Repair

The cross tube, vertical hitch pins, hair pins, horizontal hitch pins, frame mounting brackets, and fasteners must be replaced.

Parts Information**Part Number Description****CBACJ240AA Tow Bar Kit**

Each package contains the following components:

| <u>Quantity</u> | <u>Description</u> |
|-----------------|--|
| 1 | Bar, Cross Tube |
| 2 | Pin, 5/8" – Perma Hitch |
| 1 | Bracket, Passenger Side Frame Mounting |
| 1 | Bracket, Drivers Side Frame Mounting |
| 4 | Bolt |
| 4 | Nut, Handle |
| 4 | Sleeve |
| 2 | Pin, 1/2" – Hitch |
| 2 | Pin, 1/8" – Hair |
| 1 | Sheet, Instruction (p/n K6855693) |

Due to the small number of involved vehicles, no parts will be distributed initially. **Tow Bar packages should be ordered only after inspection determines that the vehicle is equipped with a MOPAR tow bar. *Very few vehicles are expected to require the tow bar repair.***

NOTE: Before performing this repair, the customer must provide the original cross tube (see Parts Return section).

Service Procedure

1. Remove and save the two plastic push pins from the front bumper closeout panel (Figure 1).

NOTE: Do not attempt to remove the closeout panel from the vehicle.

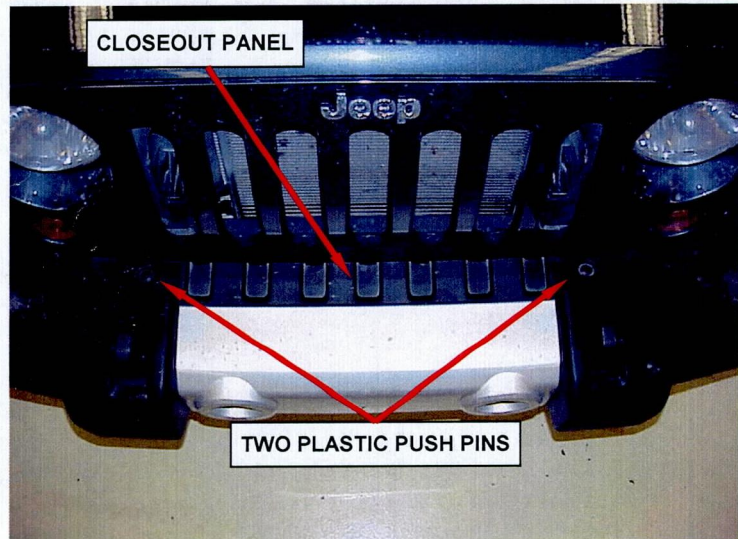

Figure 1 - Closeout Panel

2. Raise the vehicle on a hoist.
3. Remove the cross tube (if currently installed), the two horizontal pivot pins and the two hair pins (Figure 2).

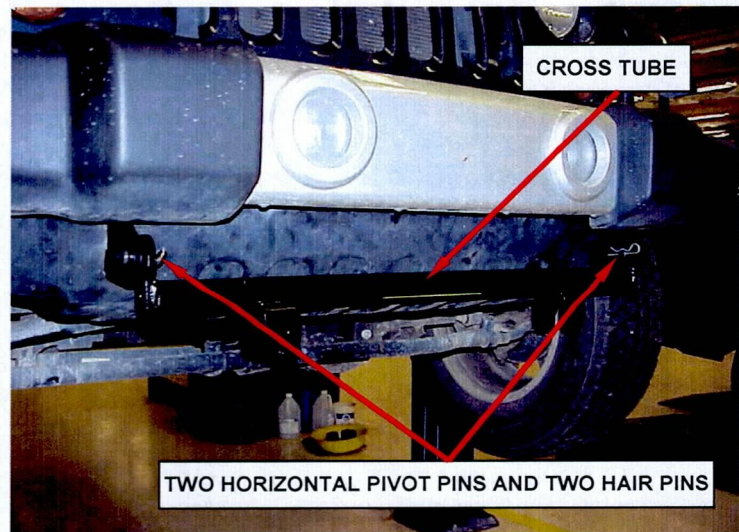

Figure 2 – Cross Tube Removal

Service Procedure (Continued)

4. Remove and save the two plastic push pins from the rear of the front air dam (Figure 3).

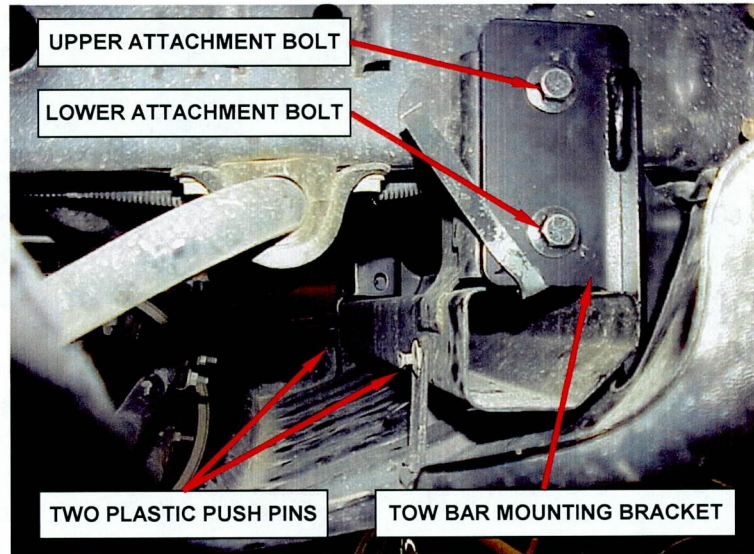

Figure 3 – Front Air Dam Rear Fasteners

5. Remove and save the four plastic push pins from the front mounting flange of the front air dam (Figure 4).
6. Remove the front air dam by slipping the front mounting flange of the air dam between the bumper cushions and the tow bar brackets (Figure 4).

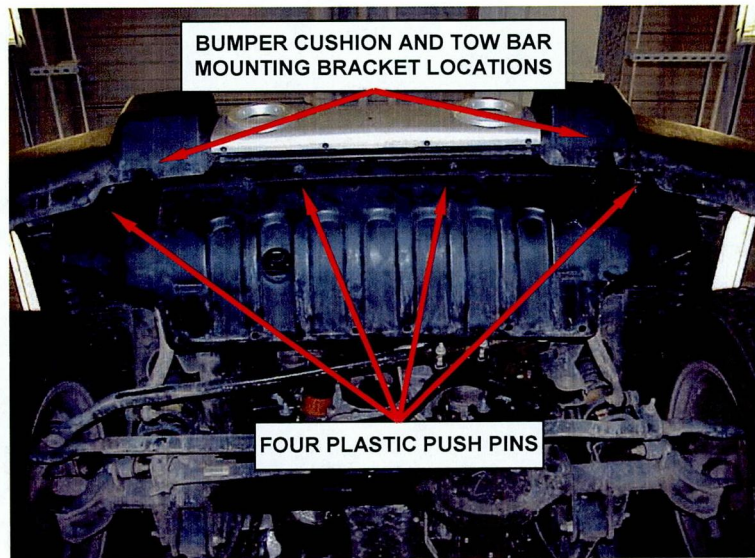

Figure 4 – Front Air Dam Fasteners

Service Procedure (Continued)

7. The tow bar mounting brackets and fasteners must be removed from both sides of the vehicle using the following procedure:

a. Access the tow bar retainer nuts by sliding the front bumper closeout panel to the side opposite the mounting bracket being removed (Figure 5).

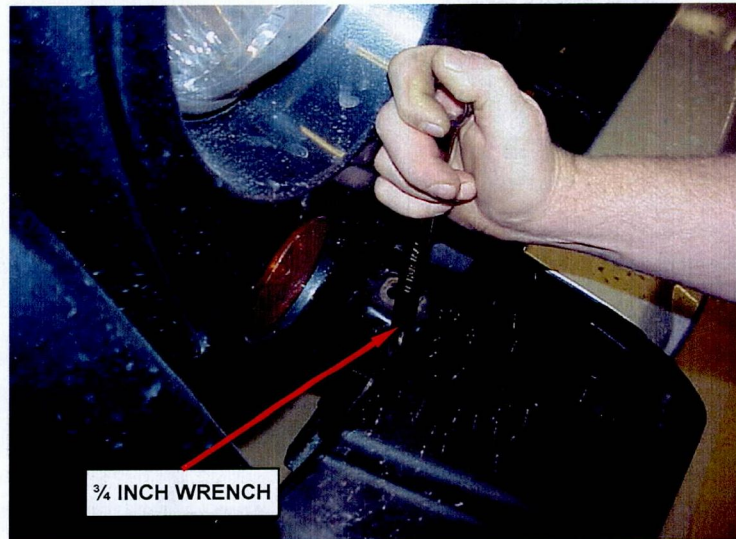

Figure 5 – Tow Bar Bracket Removal

b. Attach a $\frac{3}{4}$ inch wrench to the top tow bar bracket handle nut and remove the upper attachment bolt (Figure 3).

c. Attach the $\frac{3}{4}$ inch wrench to the lower tow bar bracket handle nut and remove the lower attachment bolt (Figure 3).

d. Repeat Steps 7a. through 7c. on the opposite side tow bar mounting bracket.

8. Install the new tow bar mounting brackets and fasteners on both sides of the vehicle using the following procedure:

a. Place a mark on the metal tabs of all four handle nuts at $2\frac{1}{4}$ inches from the nut end. Align the mark on the tab in a vice and bend the tab at a 90 degree angle in the direction opposite the weld nut. Repeat this procedure on all four handle nuts (Figure 6).

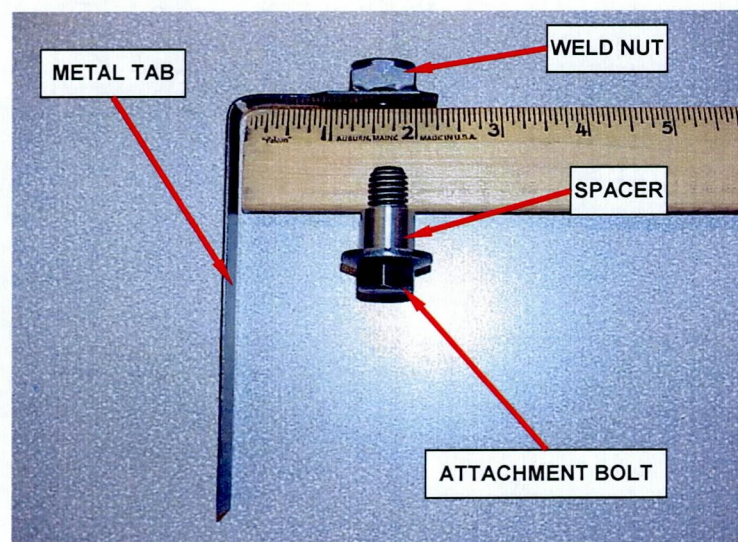

Figure 6 – Handle Nut Tab Bending Procedure

Service Procedure (Continued)

- b. Insert the four supplied spacers on the four supplied attachment bolts (Figure 6).
- c. Loosely assemble the tow bar mounting brackets to the right and left side of the frame using the handle nuts and attachment bolts with spacers (Figure 7).

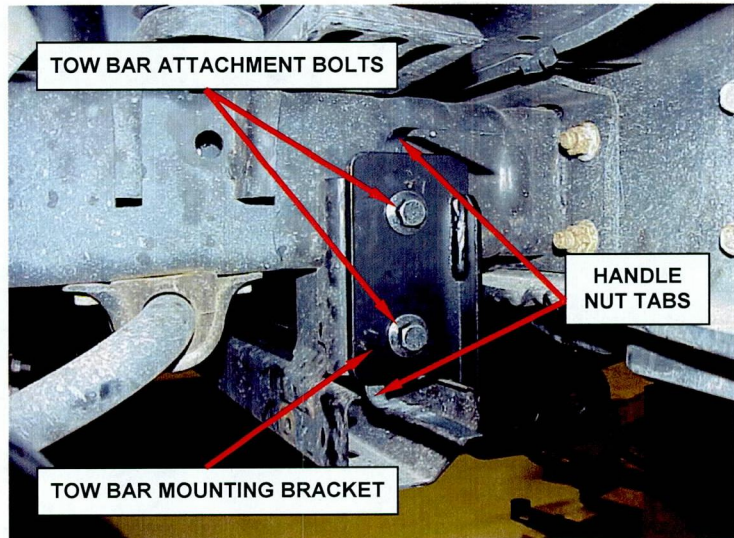

Figure 7 – Tow Bar Mounting Brackets To Frame

CAUTION: The spacers must be centered in both the frame and bracket holes. The spacers are properly centered when there is no gap between the tow bar mounting bracket and the frame or between the head of the bolt and the face of the tow bar mounting bracket (Figure 7).

- d. Bend the tab of the handle nut until it lays flush with the tow bar bracket (Figure 8).
- e. Pinch the tab of the handle nut between the tow bar bracket and the frame with a pair of vice grips (Figure 8).
- f. Tighten the tow bar mounting bracket attachment bolts to 85 ft. lbs. (115 N·m) (Figure 8).
- g. Repeat steps 8 d. through 8 f. on the remaining three attachment bolts.

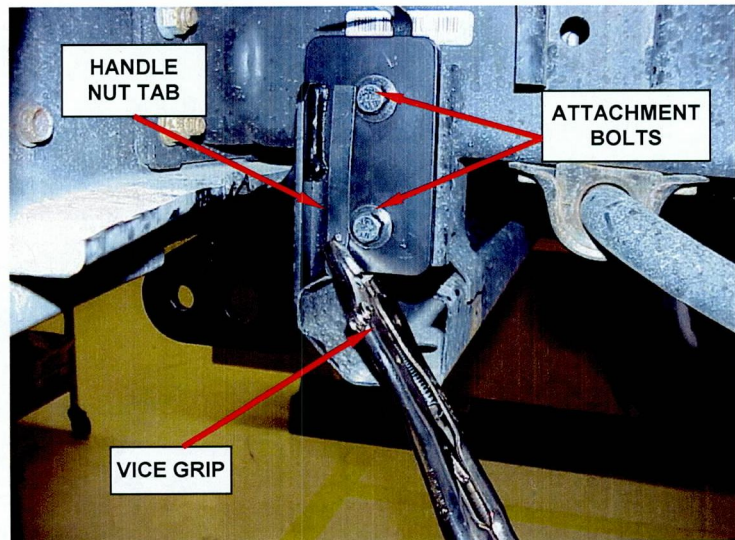
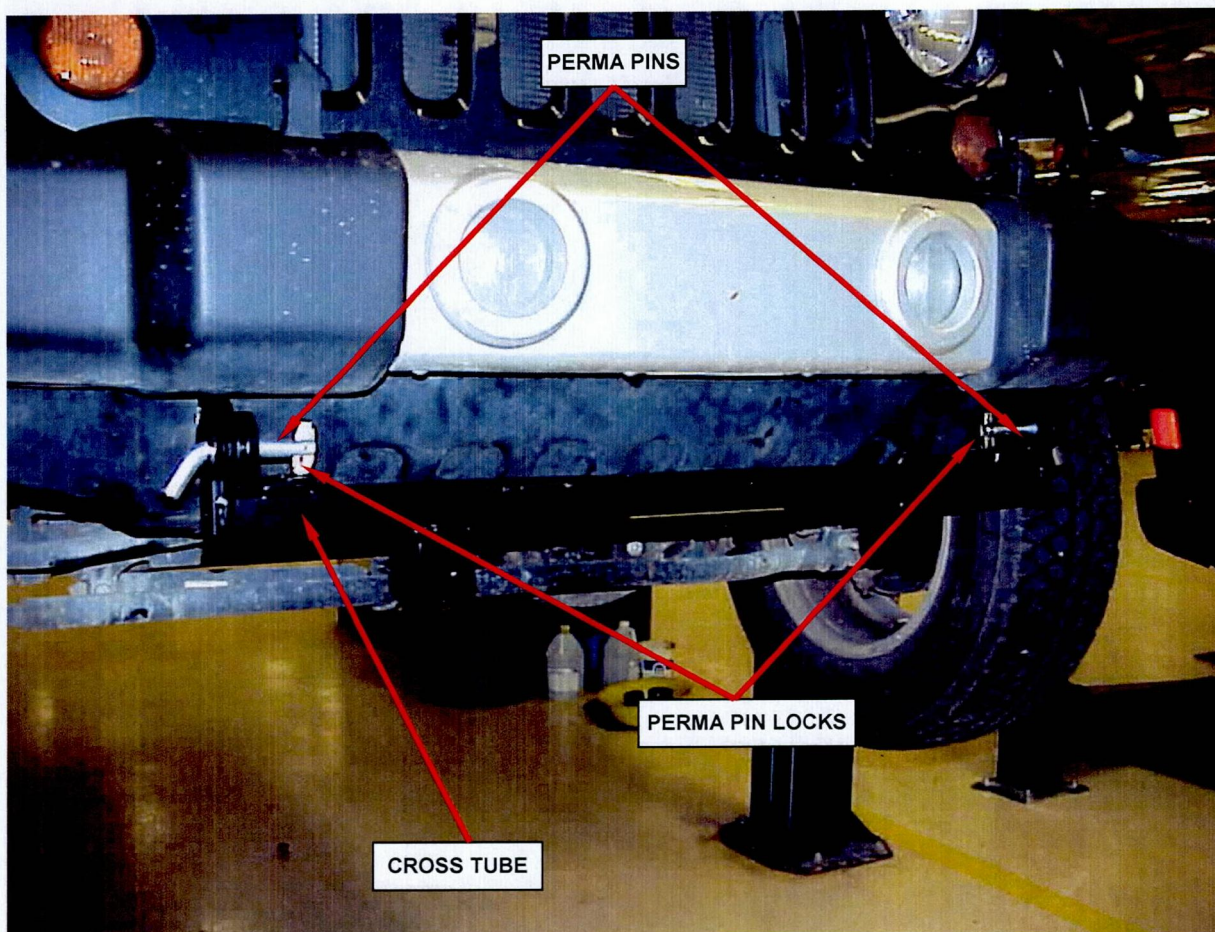

Figure 8 – Attachment Bolts

Service Procedure (Continued)**Figure 9 – Cross Tube Installation**

9. Position the front air dam on the vehicle by slipping the mounting flange of the air dam between the bumper cushions and the tow bar brackets (Figure 4).
10. Install the four plastic push pins in the mounting flange of the air dam (Figure 4).
11. Install the two plastic push pins at the rear of the air dam (Figure 3).
12. Install the supplied cross tube with the supplied Perma pins. The cross tube is properly installed when the words on the warning label are right side up. Rotate the Perma pin lock tab to a 90 degree angle and lock it in place (Figure 9).
13. Lower the vehicle from the hoist.
14. Return the front bumper closeout panel to its original position and install the two plastic push pins (Figure 1).
15. Provide the customer with the supplied front tow bar installation instruction sheet p/n K6855693, two hitch pins and two hair pins.

Completion Reporting and Reimbursement

Claims for vehicles that have been serviced must be submitted on the DealerCONNECT Claim Entry Screen located on the Service tab. Claims submitted will be used by Chrysler to record recall service completions and provide dealer payments.

| | Labor Operation | Time |
|---------------------|------------------------|------------------|
| | <u>Number</u> | <u>Allowance</u> |
| Install Tow Bar Kit | 13-J2-41-82 | 0.6 hours |

Add the cost of the recall parts package plus applicable dealer allowance to your claim.

NOTE: See the Warranty Administration Manual, Recall Claim Processing Section, for complete recall claim processing instructions.

Parts Return

The removed cross tube, vertical hitch pins, hair pins, tow bar brackets, horizontal hitch pins and fasteners must be returned to the Warranty Material Return Center.

NOTE: See the Warranty Administration Manual, Recall Claim Processing and Material Return Sections, for complete recall claim processing instructions.

Dealer Notification

To view this notification on DealerCONNECT, select “Global Recall System” on the Service tab, then click on the description of this notification.

Owner Notification and Service Scheduling

All involved vehicle owners known to Chrysler are being notified of the service requirement by first class mail. They are requested to schedule appointments for this service with their dealers. A generic copy of the owner letter is attached.

Enclosed with each owner letter is an Owner Notification postcard to allow owners to update our records if applicable.

Vehicle Lists, Global Recall System, VIP and Dealer Follow Up

All involved vehicles have been entered into the DealerCONNECT Global Recall System (GRS) and Vehicle Information Plus (VIP) for dealer inquiry as needed.

GRS provides involved dealers with an updated VIN list of their incomplete vehicles. The owner's name, address and phone number are listed if known. Completed vehicles are removed from GRS within several days of repair claim submission.

To use this system, click on the “**Service**” tab and then click on “**Global Recall System.**” Your dealer's VIN list for each recall displayed can be sorted by: those vehicles that were unsold at recall launch, those with a phone number, city, zip code, or VIN sequence.

Dealers must perform this repair on all unsold vehicles before retail delivery. Dealers should also use the VIN list to follow up with all owners to schedule appointments for this repair.

Recall VIN lists may contain confidential, restricted owner name and address information that was obtained from the Department of Motor Vehicles of various states. Use of this information is permitted for this recall only and is strictly prohibited from all other use.

Additional Information

If you have any questions or need assistance in completing this action, please contact your Service and Parts District Manager.

Customer Services Field Operations
Chrysler Group LLC



SAFETY RECALL J24 – MOPAR TOW BAR

Dear: (Name)

This notice is sent to you in accordance with the requirements of the National Traffic and Motor Vehicle Safety Act.

Chrysler has determined that a defect, which relates to motor vehicle safety, exists in some **2007 and 2008 model year Jeep® Wrangler vehicles equipped with a MOPAR brand tow bar that you purchased, or may have purchased, prior to June 2, 2008.**

The problem is... The MOPAR brand tow bar, purchased for your Jeep® Wrangler (VIN: xxxxxxxxxxxxxxxxx), may allow the towed vehicle to become detached from the tow vehicle. This can result in a crash without warning.

What your dealer will do... Chrysler will repair your vehicle free of charge (parts and labor). To do this, your dealer will replace the cross tube, vertical hitch pins, hair pins, horizontal hitch pins, frame mounting brackets, and fasteners. The work will take about 1 hour to complete. However, additional time may be necessary depending on service schedules.

What you must do to ensure your safety... Simply contact your dealer right away to schedule a service appointment. Remember to bring this letter, your vehicle and the complete tow bar kit with you to your dealer.

If you need help... If you have questions or concerns which your dealer is unable to resolve, please contact Chrysler at 1-800-853-1403.

Please help us update our records by filling out the attached prepaid postcard, if any of the conditions listed on the card apply to you or your vehicle. You may also update this information on the web at www.jeep.com/ownersreg

If you have already experienced this condition and have paid to have it repaired, you may send your original receipts and/or other adequate proof of payment to the following address for reimbursement: Chrysler Recall Customer Assistance, P.O. Box 21-8007, Auburn Hills, MI 48321-8007, Attention: Reimbursement.

If your dealer fails or is unable to remedy this defect without charge and within a reasonable time, you may submit a written complaint to the Administrator, National Highway Traffic Safety Administration, 1200 New Jersey Ave., S.E., Washington, DC 20590, or call the toll-free Vehicle Safety Hotline at 1-888-327-4236 (TTY 1-800-424-9153), or go to <http://www.safercar.gov>.

We're sorry for any inconvenience, but we are sincerely concerned about your safety. Thank you for your attention to this important matter.

Customer Services Field Operations
Chrysler Group LLC
Notification Code J24

Note to lessors receiving this recall: Federal regulation requires that you forward this recall notice to the lessee within 10 days.