

Recall Campaign

Daimler Trucks
North America LLC

December 2009
FL569A
NHTSA #09V-461

Copy of Letter to Owner Subject: KPPS Adjustable Brake Pedals

This notice is sent to you in accordance with the requirements of the National Traffic and Motor Vehicle Safety Act. This notice is also sent in accordance with the Canadian Motor Vehicles Safety Act.

Daimler Trucks North America LLC, on behalf of its wholly owned subsidiary, Freightliner Custom Chassis Corporation, has decided that a defect which relates to motor vehicle safety exists on specific Freightliner Custom Chassis B2 school bus chassis (Thomas Built Buses Saf-T-Liner C2 school buses) manufactured October 6, 2004, through November 12, 2009, with certain Kongsberg Power Products Systems (KPPS) adjustable brake pedals.

The adjustable brake pedal may loosen. The drive pin which secures the brake pedal arm to the balance of the assembly may become disengaged, this may cause a reduction in vehicle braking and/or cause the brake pedal to move out of position and interfere with throttle pedal function. A reduction in braking or interference with the throttle pedal could result in a vehicle crash.

A clamp assembly will be installed on the adjustable brake pedal arm, preventing it from loosening.

Parts are now available for authorized dealers to order. Contact your authorized dealer to arrange to have the recall performed and to ensure that parts are available at the dealership. To locate a dealer, search online at www.FreightlinerTrucks.com or contact the Warranty Campaigns Department for assistance.

When you contact your dealer, refer to campaign number **FL569A**. Once kit(s) are received at the dealership, the Recall will take approximately half an hour and will be performed at no charge to you.

IMPORTANT: When the Recall has been completed, please ensure that a label has been affixed to your vehicle referencing **FL569A**.

If you do not own the vehicle that corresponds to the identification number(s) which appears on the Recall Notification, please return the notification to the Warranty Campaigns Department with any information you can furnish that will assist us in locating the present owner. If you have leased this vehicle, Federal law requires that you forward this notice to the lessee within 10 days. If you are a subsequent stage manufacturer, Federal law requires that you forward this notice to your distributors and retail outlets within five working days. If you have paid to have this recall condition corrected prior to this notice, you may be eligible to receive reimbursement. Please see the reverse side of this notice for details.

If you are not able to have the defect remedied without charge and within a reasonable time, which is not longer than 60 days after you tender the vehicle for repair, please contact the Warranty Campaigns Department at (800) 547-0712, 7:00 a.m. to 4:00 p.m. Pacific Time, Monday through Friday, e-mail address DTNA.Warranty.Campaigns@Daimler.com, or the Customer Assistance Center at (800) FTL-HELP or (800) STL-HELP, after normal business hours. You may also wish to submit a complaint to the Administrator, National Highway Traffic Safety Administration, 1200 New Jersey Avenue, SE., Washington, DC 20590; or call the Vehicle Safety Hotline at (888) 327-4236 (TTY: 800-424-9153); or to <http://www.safercar.gov>. If your vehicle is involved in the Canadian portion, you may wish to notify Transport Canada, ASFAD, Place de Ville Tower C, 330 Sparks Street, Ottawa, ON K1A 0N5, or phone (800) 333-0510.

We regret any inconvenience this action may cause but feel certain you understand our interest in motor vehicle safety.

WARRANTY CAMPAIGNS DEPARTMENT

Enclosure

December 2009
FL569A
NHTSA #09V-461

Work Instructions

Subject: KPPS Adjustable Brake Pedals

Models Affected: Specific Freightliner Custom Chassis B2 school bus chassis (Thomas Built Buses Saf-T-Liner C2 school buses) manufactured October 6, 2004, through November 12, 2009, with certain Kongsberg Power Products Systems (KPPS) adjustable brake pedals.

NOTE: It is expected that all vehicles need the clamp assembly installed. An inspection is included to catch any vehicles that were repaired at the factory before delivery.

Inspection

1. Check the base label (Form WAR259) for a completion sticker for campaign FL569 (Form WAR260) indicating this work has been done. The base label is usually located above the driver's window on school buses. If a completion sticker for this campaign is present, no further work is needed. If a completion sticker is not present, proceed with the next step.
2. Park the vehicle on a level surface, shut down the engine, apply the parking brake, and chock the tires.
3. Check to see if a C-clamp or roll pin is installed on the adjustable brake pedal. See **Fig. 1**.
4. If either a C-clamp or a roll pin is found, no further work is needed. Clean a spot on the base label (Form WAR259), write the recall number, FL569, on a blank completion sticker (Form WAR260), and attach it to the base label. Remove the chocks from the tires.

If a C-clamp or a roll pin is not found, go to "C-clamp Installation" below.

C-clamp Installation

NOTE: The bolt threads come equipped with an application of Loctite®.

1. With the C-clamp in your hand, install the C-clamp assembly in the guide hole at the top of the brake arm casting. Make certain the C-clamp is against the casting and tighten the top bolt 40 ± 5 lbf-in (452 ± 5 N·cm). The bolt with the lockwasher should be installed at the top, as shown in **Fig. 1**, Items 4 and 5. Then tighten the bottom bolt 40 ± 5 lbf-in (452 ± 5 N·cm).
2. Remove the chocks from the tires.
3. Clean a spot on the base label (Form WAR259), write the recall number, FL569, on a blank completion sticker (Form WAR260), and attach it to the base label.

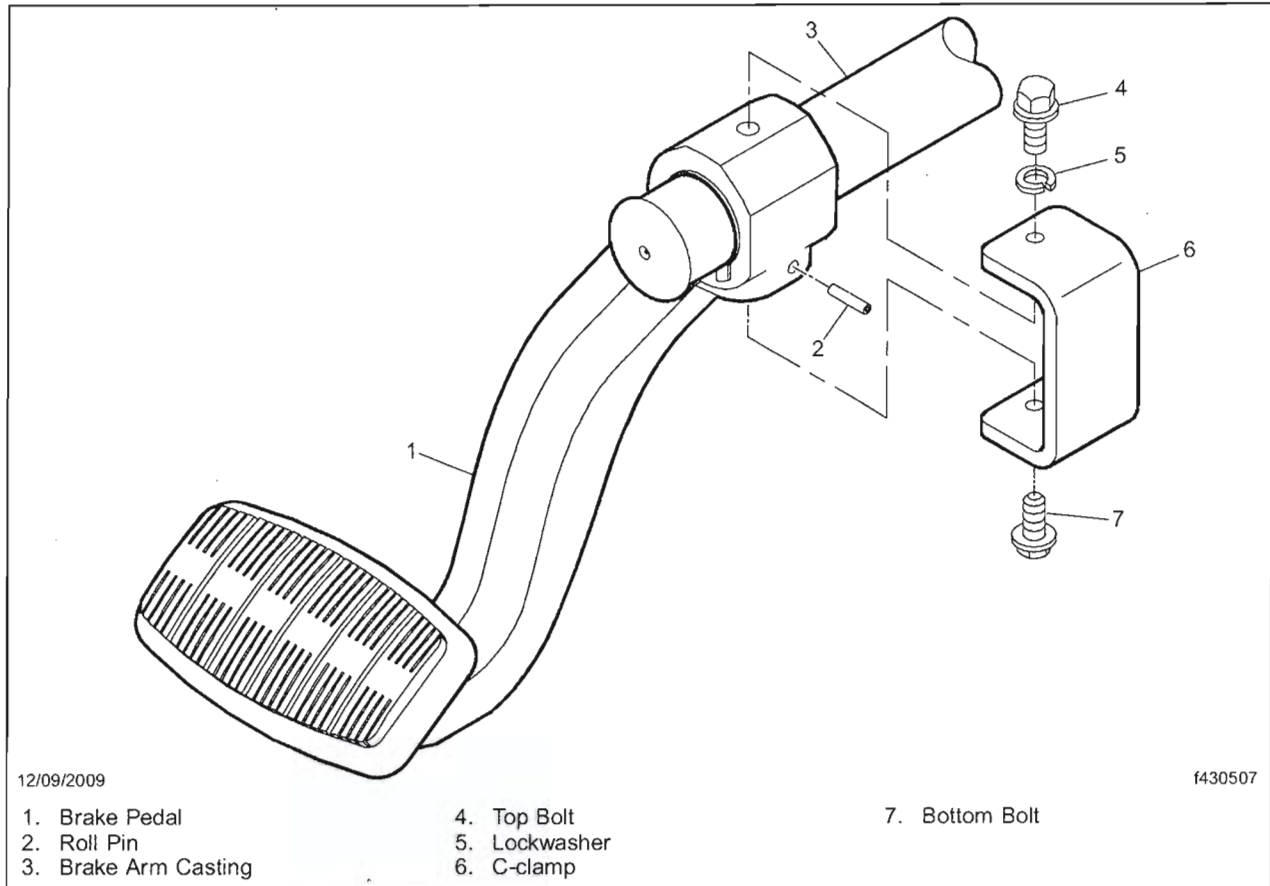

Fig. 1, Adjustable Brake Pedal Assembly