

**Volvo Cars of North America, LLC**

1 Volvo Drive
P.O. Box 914
Rockleigh, NJ 07647
Phone: 201-768-7300
www.volvocars.us

January 21, 2010

TO: ALL U.S. RETAILERS

RE: FUEL PUMP RECALL ADVISORY EXTENDED WARRANTY P29075

Volvo Cars of North America, LLC. (Volvo) has decided that a defect related to motor vehicle safety exists in the fuel pump of certain, model year 2001-2005 S80, 2001-2004 S60, V70, V70XC/XC70 and 2003-2005 XC90, vehicles that were sold, or are registered in the states of Alabama, Arizona, Arkansas, California, Florida, Georgia, Hawaii, Kentucky, Louisiana, Mississippi, Nevada, New Mexico, North Carolina, Oklahoma, South Carolina, Tennessee, Texas, Utah, Virginia, District of Columbia and U.S. Territories.

Volvo investigations has identified that a specific version of the fuel pump can when exposed to certain environmental conditions (hot climate and temperature cycling) over time and in combination of varying fuel quality, develop cracks in the fuel pump flange. If the condition occurs your customer may notice fuel smell and/or fuel seepage.

Volvo will launch a fuel pump recall and mail eligible vehicle owners a Recall Notice letter beginning in March 2010. Due to the number of vehicles involved in the fuel pump recall, customer Recall Notice letters will be mailed in stages from March 2010 – June 2010.

Prior to the customer Recall Notice letter mailings, fuel pump recall eligible vehicle owners will be mailed a Recall Advisory letter in January. The Recall Advisory letter will notify customers that their vehicle is eligible for a fuel pump recall, and that unless they have a fuel smell or fuel seepage issue, no further action is necessary until they receive the next notification (Recall Notice) when parts for their vehicle are available.

Vehicles will be marked with a temporary Recall Advisory Extended Warranty until the Recall Notice letters are mailed. This temporary extended warranty will remain in effect to cover any customer that has a fuel pump fuel smell or seepage issue and requires a fuel pump replacement prior to receiving the Recall Notice Letter.

If a vehicle owner is receiving a Recall Advisory letter and does not currently reside in one of the States or U.S. Territories listed above, or if the vehicle is not part of the model years listed above, it is because our records indicate that the vehicle was originally sold in one of these States or U.S. Territories, or has been fitted with the concerned component and is eligible for the Recall Advisory Extended Warranty.

OWNER NOTIFICATION

Owner notification letter mailings are scheduled to begin this week.

RETAILER RESPONSIBILITIES

All work performed under Fuel Pump Recall Advisory Extended Warranty P29075 is free of charge to the owner. In the event that an eligible vehicle owner does not have a notification letter, and the vehicle has a fuel pump condition described in the attached documents, the owner is not to be refused this work.

Your regional representative will follow up to ensure that this Recall Advisory Extended Warranty is proceeding smoothly.

A complete description of the Recall Advisory Extended Warranty requirements and claim submission procedures are attached to this package.

It is the retailer's responsibility to review the details provided in the materials listed below with all involved personnel.

- Service Manager Bulletin
- Retailer Tech Journal
- Parts Bulletin

Your cooperation in following the attached instructions for Recall Advisory Extended Warranty P29075 is greatly appreciated.

Drive Safely,

Volvo Cars of North America, LLC.

<h1>VOLVO</h1> <h2>Service Manager Bulletin</h2>				TITLE:		GROUP:	NO:	
				Fuel Pump Recall Advisory Extended Warranty P29075		23	220	
				Model Year 2001-2005 S80, 2001-2004 S60, V70 and V70XC/XC70, 2003-2005 XC90		ISSUING DEPARTMENT:		
						Warranty		
				REFERENCE BULLETINS:		CARMARKET:		
				RTJ 22388 PB 23-220		United States		
Service Personnel: read and initial.	SERVICE MANAGER	SERVICE WRITER	WARRANTY ADMINISTRATOR	DATE:		YEAR	MONTH	DAY
				2010 01 21				
				Page 1 of 4				

- A. FUEL PUMP RECALL ADVISORY EXTENDED WARRANTY P29075 DESCRIPTION
- B. VEHICLES INVOLVED
- C. PARTS INFORMATION/PARTS RETURN
- D. OWNER NOTIFICATION
- E. VEHICLES IN RETAILER INVENTORY
- F. RETAILER RESPONSIBILITY
- G. REIMBURSEMENT PROCEDURES
- H. TECHNICIAN COMPETENCY REQUIREMENT
- I. RETAILER ALLOWANCE AND CLAIM SUBMISSION

A. FUEL PUMP RECALL ADVISORY EXTENDED WARRANTY P29075 DESCRIPTION

Volvo Cars of North America, LLC. (Volvo) has decided that a defect related to motor vehicle safety exists in the fuel pump of certain model year 2001-2005 S80, 2001-2004 S60, V70, V70XC/XC70 and 2003-2005 XC90 vehicles that were sold, or are registered in the states of Alabama, Arizona, Arkansas, California, Florida, Georgia, Hawaii, Kentucky, Louisiana, Mississippi, Nevada, New Mexico, North Carolina, Oklahoma, South Carolina, Tennessee, Texas, Utah, Virginia, District of Columbia and U.S. Territories.

Volvo investigations has identified that a specific version of the fuel pump can when exposed to certain environmental conditions (hot climate and temperature cycling) over time and in combination of varying fuel quality, develop cracks in the fuel pump flange. If the condition occurs your customer may notice fuel smell and/or fuel seepage.

Volvo will launch a fuel pump recall and mail eligible vehicle owners a Recall Notice letter beginning in March 2010. Due to the number of vehicles involved in the fuel pump recall, customer Recall Notice letters will be mailed in stages from March 2010 – June 2010. Prior to the customer Recall Notice letter mailings, fuel pump recall eligible vehicle owners will be mailed a Recall Advisory letter in January 2010. The Recall Advisory letter will notify customers that their vehicle is eligible for a fuel pump recall, and that unless they have a fuel smell or fuel seepage issue, no further action is necessary until they receive the next notification (Recall Notice) when parts for their vehicle are available.

"Fixed Right — First Time"



Vehicles will be marked with a temporary Recall Advisory Extended Warranty until all the Recall Notice letters are mailed. This temporary extended warranty will remain in effect to cover any customer that has a fuel pump fuel smell or seepage issue and requires a fuel pump replacement prior to receiving the Recall Notice Letter.

(Please refer to vehicle marking information in section “B” below.)

If a vehicle owner is receiving a Recall Advisory letter and does not currently reside in one of the States or U.S. Territories listed above, or if the vehicle is not part of the model years listed above, it is because our records indicate that the vehicle was originally sold in one of these States or U.S. Territories, or has been fitted with the concerned component and is eligible for the Recall Advisory Extended Warranty.

If the vehicle currently is under a fuel pump extended warranty, this is now superseded by Recall Advisory Extended Warranty P29075.

B. VEHICLES INVOLVED

NOTE: RETAILER MUST CONFIRM VEHICLE ELIGIBILITY PRIOR TO BEGINNING REPAIR FOR THIS CAMPAIGN.

Vehicle eligibility should be confirmed:

- **Prior to the customer Recall Notice letter mailings, fuel pump recall eligible vehicles will be marked as eligible for Recall Advisory Extended Warranty P29075. In VRC² Vehicle Inquiry the message “RC ADV EXTWTY P29075” will appear for these vehicles. When all the customer Recall Notice letters mailings are completed in June, the Recall Advisory Extended Warranty P29075 will be closed and the vehicles will be marked eligible for the fuel pump recall. Vehicles with fuel pump replacements performed due to a customer fuel smell or fuel seepage concern under the Recall Advisory Extended Warranty P29075 will be marked complete for the fuel pump recall. No customer Recall Notice letter will be mailed to these vehicle owners.**

All vehicles should be checked for any other incomplete recalls or service campaigns or service upgrades. All open Recall, Service Campaign or Service Action repairs should be completed.

RETAILER VEHICLE CAMPAIGN LIST

A “Retailer Campaign List” will be posted on VRC² in the Reports Menu under the Service Tab when the Recall Notice letter mailing is completed. This list details all affected vehicles that are on record as being retailed or currently in stock at your facility, and is updated monthly. Vehicle eligibility must be confirmed via VRC² prior to performing a repair under the Recall Advisory Extended Warranty.

C. PARTS INFORMATION / PARTS RETURN

Fuel Pumps will be requested to be held for 30 days from payment date for Volvo representative inspection.

D. OWNER NOTIFICATION

Recall Advisory letters will be mailed to all owners eligible for the fuel pump recall in January 2010. Due to the number of vehicles involved in fuel pump recall, Volvo will mail Recall Notice letters in stages from March 2010 – June 2010 beginning with model year 2001 vehicles.

E. VEHICLES IN RETAILER INVENTORY

All vehicles in retailer's inventory and qualifying for the Recall Advisory Extended Warranty should not have a fuel pump replacement unless they have a fuel smell or fuel seepage issue. No further action is necessary until the next notification (Recall Notice letter) is mailed when parts for the vehicle are available.

F. RETAILER RESPONSIBILITY

Repairs performed under the Recall Advisory Extended Warranty are free of charge to the owner. If a customer presents a Recall Advisory letter for a vehicle that is not found via the VRC² inquiry function, please verify that the letter applies to the customer's vehicle and call the Warranty Assistance Desk at 1-800-807-7712 for instructions. If the Warranty Assistance Desk verifies that the vehicle qualifies for the Recall Advisory Extended Warranty, please perform the repair and place the Recall Advisory letter in the customer's file. Under no circumstances should a customer be denied the required service without a confirmation from VCNA.

G. REIMBURSEMENT PROCEDURES FOR CUSTOMERS WHO PREVIOUSLY PAID FOR THIS REPAIR

Customers send the **repair order** with a **copy of the customer letter** to:

Volvo Recall Advisory P29075 Reimbursement
c/o The Advertising Checking Bureau, Inc.
P.O. Box 1919
Memphis, TN 38101

- To avoid delays do not send this information to any other location.
- The repair order must show that the customer previously paid for a fuel pump repair with the symptoms described in this bulletin, and include the amount paid, the date of payment, and the customer's name and address. If the repair order does not include the vehicle's VIN number, the customer should provide some other documentation reflecting that number, or simply write that VIN number onto the repair order.

Customers can call 866-637-3774 to check on the status of their claim.

- Please allow 8 weeks for reimbursement.

H. TECHNICIAN COMPETENCY REQUIREMENT

The technician competency requirement for this campaign repair is: Level 2.

I. RETAILER ALLOWANCE AND CLAIM SUBMISSION (LONG FORM APPLICATION)

REPAIRS PERFORMED UNDER THE RECALL ADVISORY EXT WARRANTY

Claim Type: P29075
Main Operation Number: 23294
Failed Part Number: 30761742, 30761743, 30761744, 31273510
Cause Code: 10
Symptom Code: XY – Leakage

FUEL PUMP CHECK & REPLACEMENT IS NOT NECESSARY

<u>Operation Number</u>	<u>Description</u>	<u>Qty</u>	<u>Model</u>	<u>Time (Hrs)</u>
23295	Pump Odor / Leakage check	1	S60, V70, S80	0.9
			XC90 5 Seat	0.8
			XC90 7 Seat	1.5

**FUEL PUMP CHECK & REPLACEMENT IS NECESSARY
(Both Operations Below Apply)**

<u>Operation Number</u>	<u>Description</u>	<u>Qty</u>	<u>Model</u>	<u>Time (Hrs)</u>
23295	Pump Odor / Leakage check	1	S60, V70, S80	0.9
			XC90 5 Seat	0.8
			XC90 7 Seat	1.5
23294	Fuel Pump Replace	1	S60, V70, S80	0.9
			XC90 5 Seat	1.5
			XC90 7 Seat	0.9



Nothing can replace them.

Parts Bulletin

SUBJECT Fuel Pump Recall Advisory Extended Warranty P29075, MY 2001-2004 V70, V70XC/XC70 & S60, 2001-2005 S80, 2003-2005 XC90				GROUP	23		NO	220
				MARKET	United States		PAGE	1 of 2
COPY TO / CIRCULATIONS (PLEASE INITIAL)								
GENERAL MGR	PARTS MGR	SERVICE MGR	SALES MGR	DATE	YEAR	MONTH	DAY	
					2010	01	21	

NOTE: PARTS WILL NOT BE ALLOCATED FOR THIS EXTENDED WARRANTY

Reference Bulletins: **SMB 23-220**
RTJ 22388

Volvo Cars of North America, LLC. (Volvo) has decided that a defect related to motor vehicle safety exists in the fuel pump of certain model year 2001-2005 S80, 2001-2004 S60, V70, V70XC/XC70 and 2003-2005 XC90 vehicles that were sold, or are registered in the states of Alabama, Arizona, Arkansas, California, Florida, Georgia, Hawaii, Kentucky, Louisiana, Mississippi, Nevada, New Mexico, North Carolina, Oklahoma, South Carolina, Tennessee, Texas, Utah, Virginia, District of Columbia and U.S. Territories.

Volvo investigations has identified that a specific version of the fuel pump can when exposed to certain environmental conditions (hot climate and temperature cycling) over time and in combination of varying fuel quality, develop cracks in the fuel pump flange. If the condition occurs your customer may notice fuel smell and/or fuel seepage.

Volvo will launch a fuel pump recall and mail eligible vehicle owners a Recall Notice letter beginning in March 2010. Due to the number of vehicles involved in the fuel pump recall, customer Recall Notice letters will be mailed in stages from March 2010 – June 2010.

Prior to the customer Recall Notice letter mailings, fuel pump recall eligible vehicle owners will be mailed a Recall Advisory letter in January. The Recall Advisory letter will notify customers that their vehicle is eligible for a fuel pump recall, and that unless they have a fuel smell or fuel seepage issue, no further action is necessary until they receive the next notification (Recall Notice) when parts for their vehicle are available.

Vehicles will be marked with a temporary Recall Advisory Extended Warranty until the Recall Notice letters are mailed. This temporary extended warranty will remain in effect to cover any customer that has a fuel pump fuel smell or seepage issue and requires a fuel pump replacement prior to receiving the Recall Notice Letter.

(See page 2 for part numbers.)

"Fixed Right — First Time"



Printed in USA on recycled paper containing a minimum of 50% wastepaper and 10% post-consumer waste.

© 2010 VOLVO CARS OF NORTH AMERICA, LLC

SUBJECT Fuel Pump Recall Advisory Extended Warranty P29075, MY 2001-2004 V70, V70XC/XC70 & S60, 2001-2005 S80, 2003-2005 XC90	GROUP 23	NO 220	DATE 2010-01-21	PAGE 2 of 2
----------------------------------------------------------------------------------------------------------------------------------	--------------------	------------------	---------------------------	-----------------------

The following part numbers apply:

Part Number	Description	Qty
30761742	Pump Unit	1
30761743	Pump Unit	1
30761744	Pump Unit	1
31273510	Pump Unit	1
9183708	O-Ring	2
985719	Flange Screw (XC90)	12
987891	Flange Lock Nut (non XC90)	1
986503	Washer (non XC90)	1
985055	Flange Screw (non XC90)	1
985047	Flange Screw (non XC90)	1

- There will not be an allocation of parts sent to your Retail facility.
- Please only order these parts based on the determination that this repair is necessary, after receiving a request from a customer to schedule a service appointment.



Retailer Technical Journal 22388
Fuel Pump Recall Advisory Extend Warranty
P29075

Date 01-20-2010

Volvo Cars of North America, LLC
Technical Engineering

Reference: VIDA, SMB 23-220

Note! If using a printed copy of this Retailer Technical Journal, first check for the latest online version.

AFFECTED VEHICLES:

Model	Type	Model year	Chassis range
S80	184	2001-2005	0176255-0406781
V70	285	2001-2004	0064306-0459385
S60	384	2001-2004	0006099-0422140
XC70	295	2001-2004	0012318-0173074
XC90	275	2003-2005	0000690-0134089

DESCRIPTION:

Volvo Cars of North America, LLC. (Volvo) has decided that a defect related to motor vehicle safety exists in the fuel pump of certain, model year 2001-2005 S80, 2001-2004 S60/V70/XC70 and 2003-2005 XC90, vehicles that were sold, or are registered in the states of Alabama, Arizona, Arkansas, California, Florida, Georgia, Hawaii, Kentucky, Louisiana, Mississippi, Nevada, New Mexico, North Carolina, Oklahoma, South Carolina, Tennessee, Texas, Utah, Virginia, District of Columbia and U.S. Territories.

Volvo investigations has identified that a specific version of the fuel pump can when exposed to certain environmental conditions (hot climate and temperature cycling) over time and in combination of varying fuel quality, develop cracks in the fuel pump flange. If the condition occurs your customer may notice fuel smell and/or fuel seepage.

Volvo will launch a fuel pump recall and mail eligible vehicle owners a Recall Notice letter beginning in March 2010. Due to the number of vehicles involved in the fuel pump recall, customer Recall Notice letters will be mailed in stages from March 2010 – June 2010. Prior to the customer Recall Notice letter mailings, fuel pump recall eligible vehicle owners will be mailed a Recall Advisory letter in January 2010. The Recall Advisory letter will notify customers that their vehicle is eligible for a fuel pump recall, and that unless they have a fuel smell or fuel seepage issue, no further action is necessary until they receive the next notification (Recall Notice) when parts for their vehicle are available.

Vehicles will be marked with a temporary Recall Advisory Extended Warranty until the Recall Notice letters are mailed. This temporary extended warranty will remain in effect to cover any customer that has a fuel pump fuel smell or seepage issue and requires a fuel pump replacement prior to receiving the Recall Notice Letter.

SERVICE: Inspect and/or replace fuel pump assembly according to this document.

TOOLS:

Description	Quantity	Part number
Fuel tank caddy	1	9814070*
Adapter	1	9995480
Adapter	1	9995484
Adapter	1	9995721
Wrench	1	9995720
Leak tester	1	9512761*

*Or equivalent equipment.

MATERIALS: If needed

Description	Quantity	Part number
Pump unit	1	30761742*
Pump unit	1	30761743*
Pump unit	1	30761744*
Pump unit	1	31273510*
O-ring	2	9183708
Flange screw (seat back)	1	985047
Flange screw (mounting child seat)	1	985055
Flange lock nut (mounting child seat)	1	987891
Washer (mounting child seat)	1	986503
Lubricant	0.1	1161580**
Flange screw(XC90)	12	985719

*Chassis and model specific see VIDA

** Standard shop supply

Note! Some variation in the illustrations may occur, but the essential information is always correct.

Note! Exposing steps in this procedure may contain installation details.

1.

Preparations

Note! Ensure that nobody can insert the ignition key during work.

Remove the key from the ignition.

Note! In order to carry out this action in the most efficient way, the fuel pump check should start with draining the fuel tank in accordance with the stated procedure, parallel with the fuel pump checking procedure.

2.

Safety precautions for handling fuel

Warning! Avoid ignition sources.

Use breathing protection, type A/brown (organic substances) filter mask when there is a risk of breathing in fuel vapours.

Use protective gloves to avoid skin contact with fuel.

Ensure that there is good ventilation when draining and filling fuel.

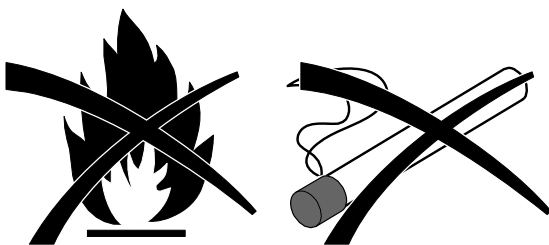

Draining the fuel tank 3.

Insert the heavy duty hose 1.3 m into the fuel filler pipe, measured from the edge of the opening of the filler pipe.

Connect to the relevant draining equipment.

Pump until air comes out.

Warning! Ensure that ventilation is good when draining the fuel.

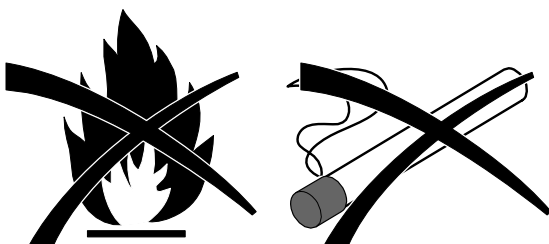

4.

Draining the fuel lines

Remove the protection on the valve located on the fuel rail.

Connect adapter 9995484 to the draining equipment 9814070 (or similar specification).

Connect the adapter to the valve on the fuel rail in the locked position (image 1 = valve closed).

Start the draining equipment.
Release the adapter (image 2 = valve open).

Raise the vehicle.

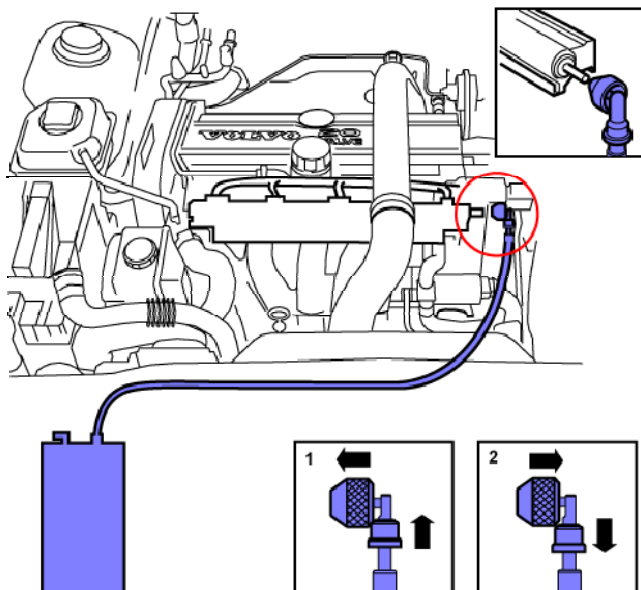

5.

Remove the protection on the valve located on the fuel filter.

For easier access, remove the right-hand rear wheel.

Connect bleed hose 9995480 to the valve before the fuel filter.

It takes approximately 2 minutes to drain the lines.

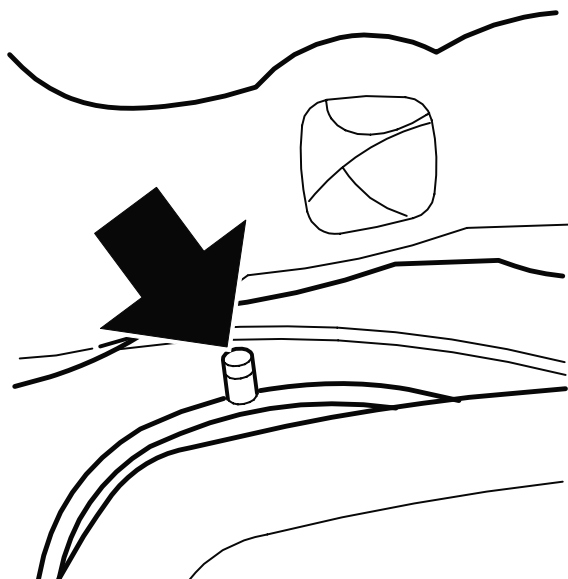

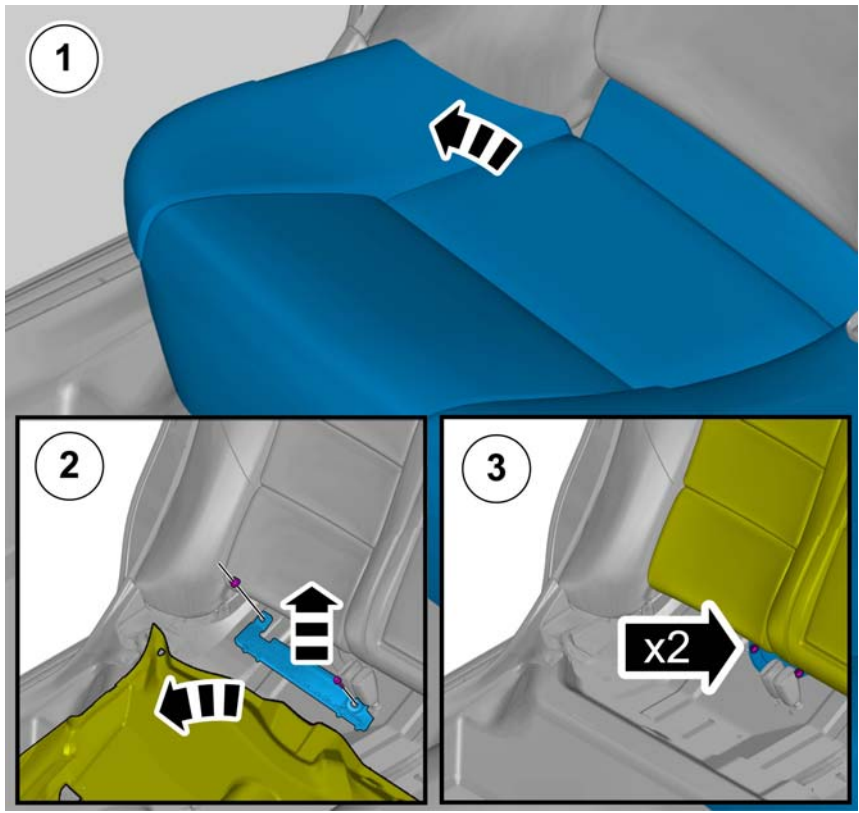

Exposing for checking
S60/S80

- Remove the seat cushion
- Fold the front section of the cargo compartment to one side.
- Remove the mounting for the child seat.
- Screw M12. Torque 40Nm.
- Nut M10. Torque 30Nm.

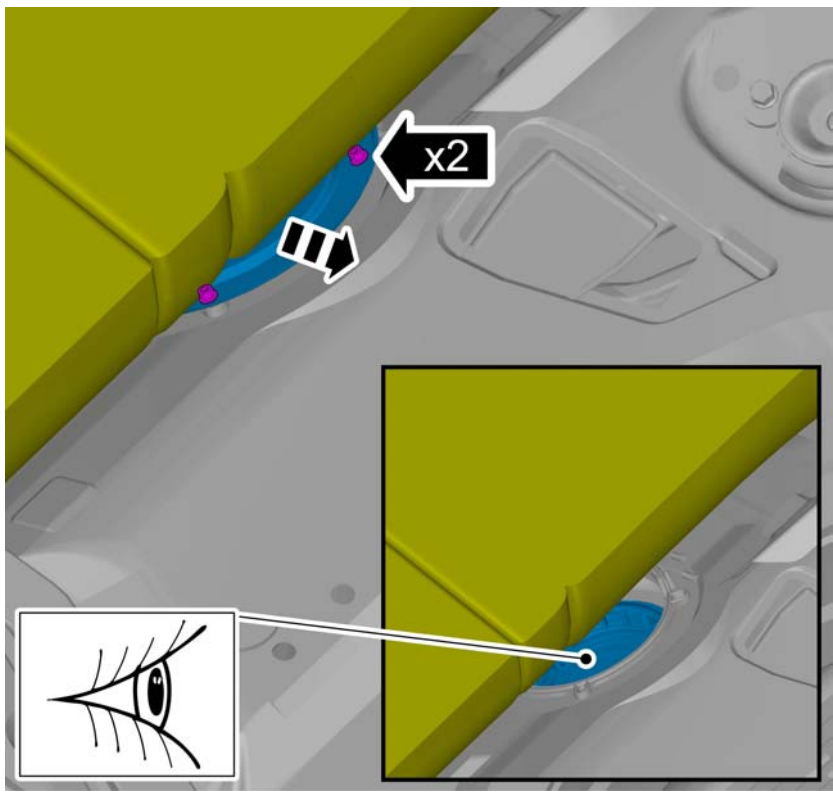

- Fold the insulation mat to one side
- Remove the cover from above the fuel pump.
- Nut M6. Torque 6 Nm.
- Check for visible fuel leakage from cracks in the pump flange or fuel odor. See pic. On pg. 7
- Use Leak tester 9512761 to detect any fuel odours.
- If the check reveals that the pump is fault-free start resetting by refilling with fuel.
- Perform general resetting in reverse order.
- If the check reveals that the fuel pump must be replaced, carry out work according to these instructions.

Caution! Make sure that new screws and nuts are installed

Nut M6. Torque 6 Nm.

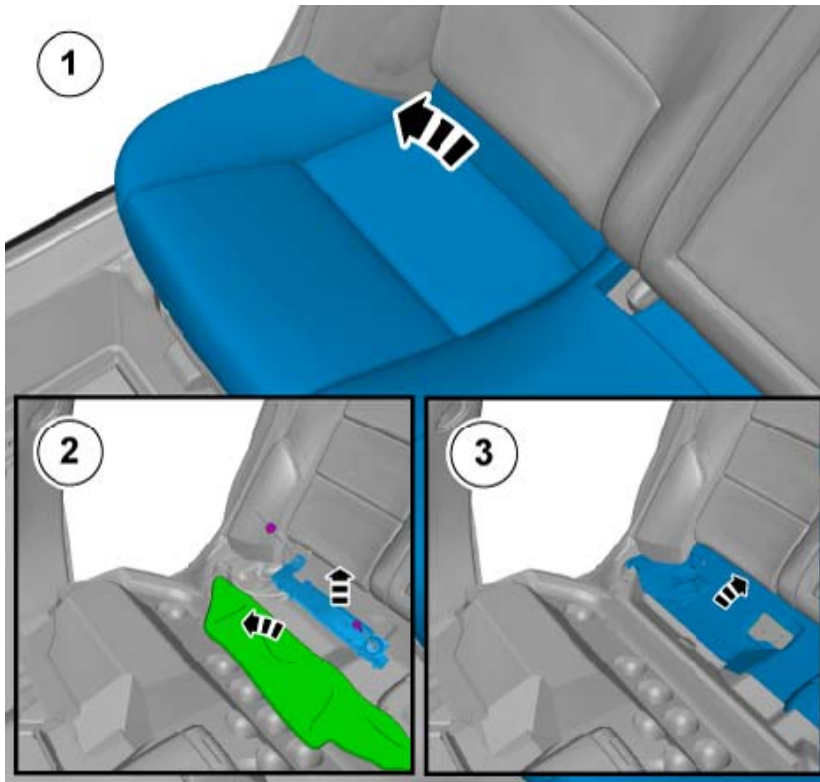

Exposing for checking

V70/XC70

Fold the seat cushion forward.

Remove the cargo compartment floor. Applies to vehicles with (5 seats).

Only applies to vehicles with extra seat, remove the front section of the floor in the cargo compartment.

Remove the mounting for the child seat.

Screw M12. Torque 40 Nm.

Nut M10. Torque 30Nm.

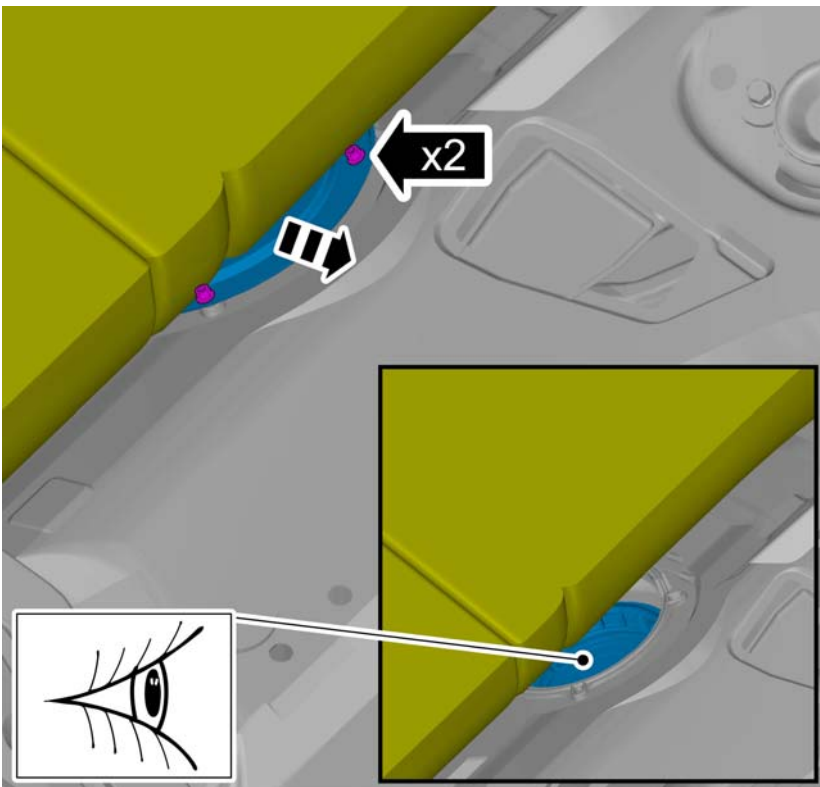

Fold the insulation mat to one side

Remove the cover from above the fuel pump.

Nut M6. Torque 6 Nm.

Check for visible fuel leakage from cracks in the pump flange or fuel odor. See pic. On pg. 7

Use Leak tester 9512761 to detect any fuel odours.

If the check reveals that the pump is fault-free start resetting by refilling with fuel.

Perform general resetting in reverse order.

If the check reveals that the fuel pump must be replaced, carry out work according to these instructions.

Caution! Make sure that new screws and nuts are installed

Nut M6. Torque 6 Nm.



IMPORTANT: Inspect the entire flange surface for cracks and leakage if a fuel odor is present.

Fuel pump replacement

Note! Replace the fuel pump from the point where the check of the fuel pump identity finished.

1.

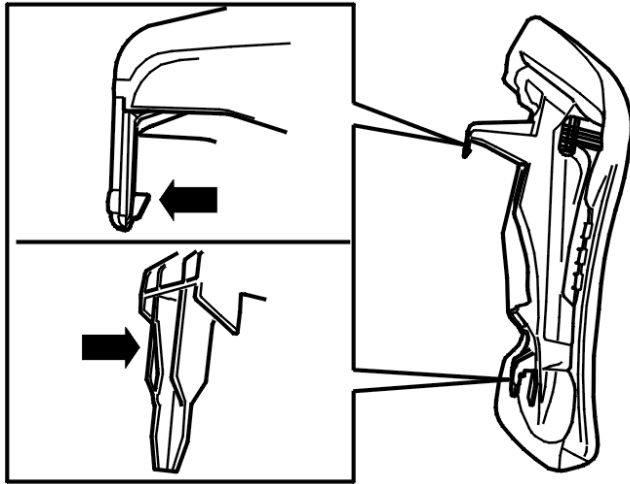

Remove the right-hand side cushion, see illustration.

Insert a hand between the mounting and the wheel arch panel and press in the catch.

With the other hand, press in the upper mounting's catch towards the panel and press the bolster upwards.

2.

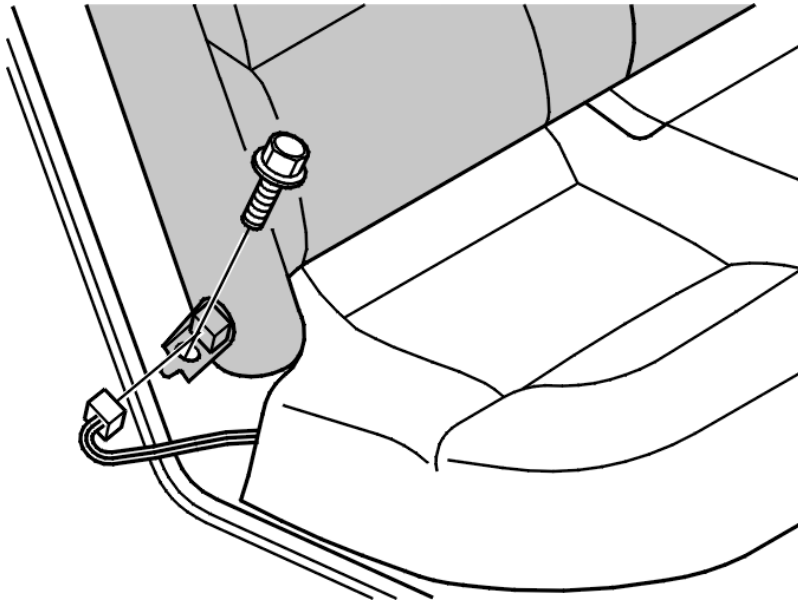

Disconnect the connector at the hinge on the right-hand side.
Remove the screw on the mounting for the hinge on the right-hand side.
Lift the backrests out.

3.

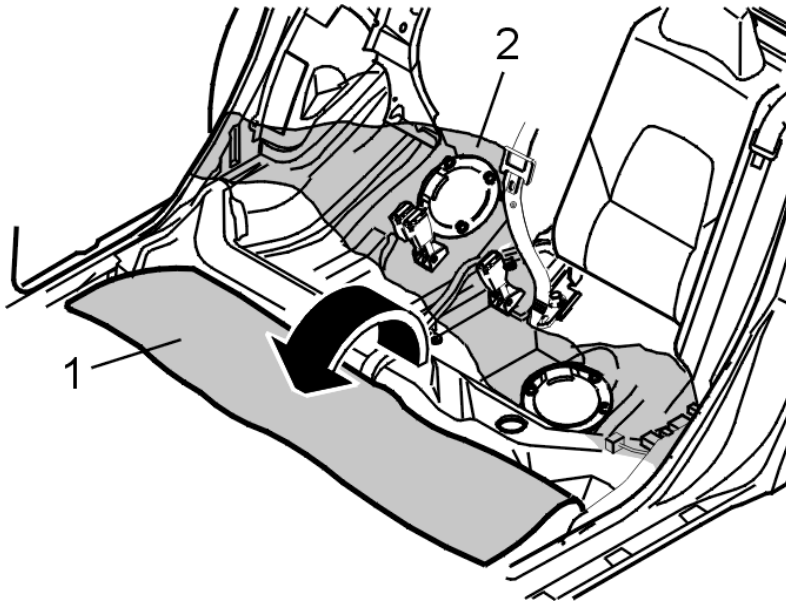

Push the carpet (1) to one side.
Remove the insulation panel.
Cover the area (2) around the cover
and between the doors with
absorbent material.

Caution! Ensure that dirt does not enter the tank.

4.

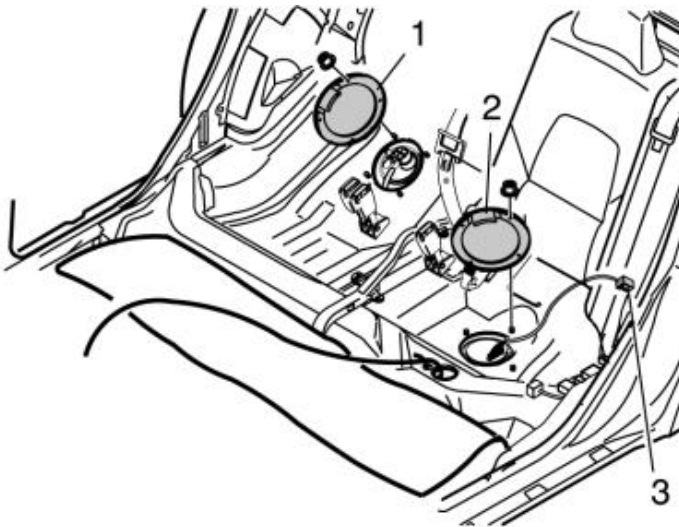

Remove the cover (2) from over the
tank units.
Detach the left-hand fuel tank unit's
connector (3). (Certain models only)
Detach the right-hand fuel tank unit's
connector. (Certain models only)

Remove the hoses from the right-
hand fuel tank unit.

5.

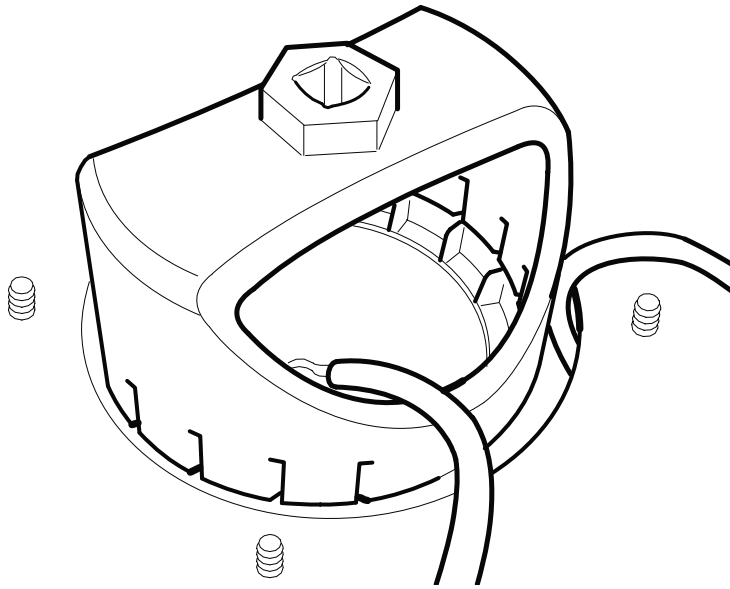

Use wrench 9995720.
Clean and remove all dirt at the right and left-hand fuel tank units.
Open the right-hand fuel tank unit.
Insert the thick hose, see image, and draw up the remaining fuel from the bottom of the right-hand side of the tank.
Connect hose 9995721 to the heavy duty hose. Suck out the remaining fuel from the bottom of fuel tank unit reservoir.

Warning! Ensure that ventilation is good when draining the fuel.

6.

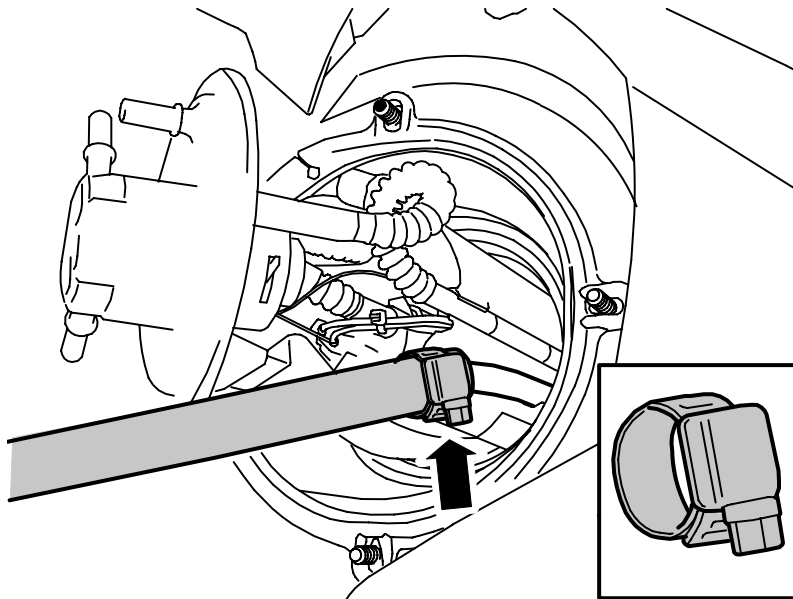

Carefully detach the overflow pipe from the reservoir.
Connect the hose from the draining - unit to the overflow pipe using a hose clamp.
Pump until air comes out.

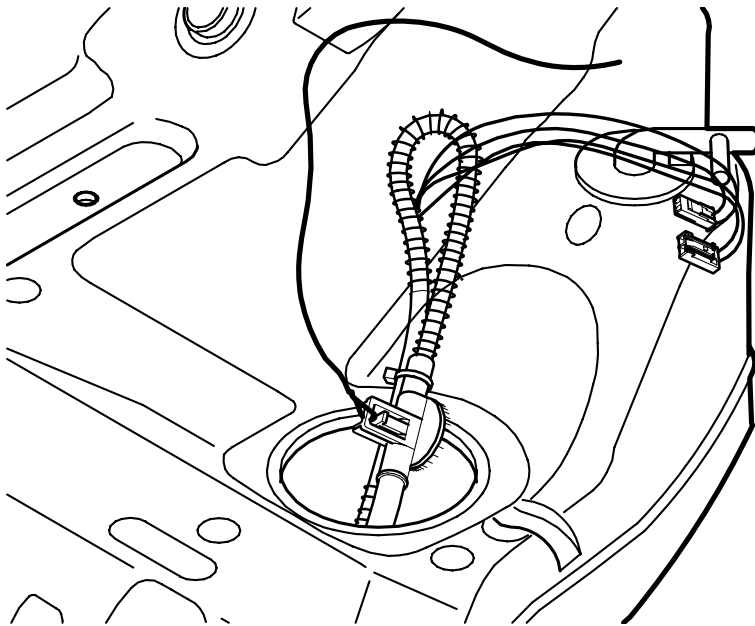

Fuel pump replacement 7.

Use wrench 9995720.
Open the left-hand fuel tank unit.

Remove:

- the two connectors from the underside of the left-hand level sensor
- left-hand level sensor from its underlying ejector

Note! Secure a wire in the area of the ejector.

The wire must be sufficiently long that it reaches over to the opposite side of the tank with some excess remaining to ensure that it does not slide into the tank.

The wire is needed to pull the hoses and wiring back to the left-hand side of the tank after the fuel tank unit has been replaced.

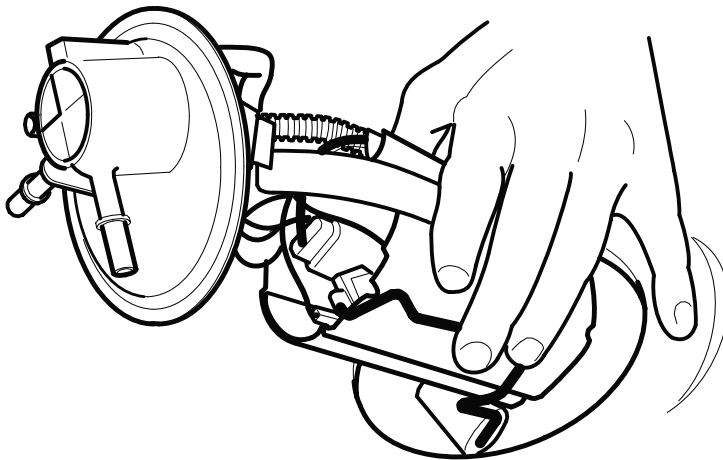

Removal of the right-hand fuel pump and level sensor 8.

Grip the holder to the right of the fuel pump and level sensor. Pinch the float in its lowest position.

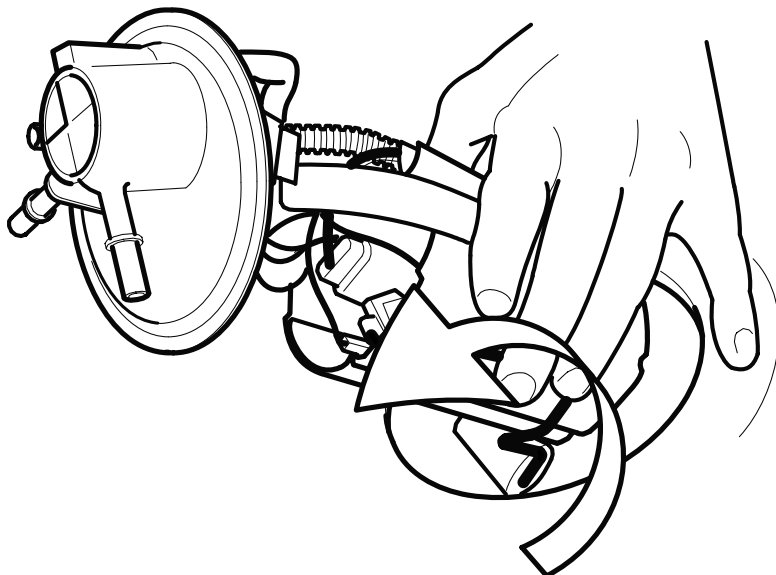

Warning! Take care with fuel spillage.

Carefully and slowly pull up the reservoir. Carefully work it out. Pull the hoses out from the tank without pulling up the entire wire from the right-hand hole in the tank.

Caution! It is important that the float arm is not broken or bent.

Remove the wire from the ejector for the old fuel pump and level sensor. Remove the o-rings for the left and right fuel pump and level sensor. Clean the seats of the level sensors by sucking up any contaminants.

Install the right-hand fuel pump and level sensor and left-hand level sensor in the tank.

10.

Lubricate the new O-rings with lubricant (see the materials list) and install them.

Install the wire on the new fuel pump's and level sensor's ejector. Insert the hoses and lines into the tank via the right tank hole. Grip the right-hand level sensor and fuel pump holder and pinch the float in its lowest position. Carefully and slowly lower the reservoir. Carefully work the reservoir into place.

Pull the wire so that the hoses and wiring end up on the left side of the tank.

Install the:

- left-hand level sensor on the ejector
- the connectors on the underneath of the left-hand level sensor

Remove the wire from the ejector.

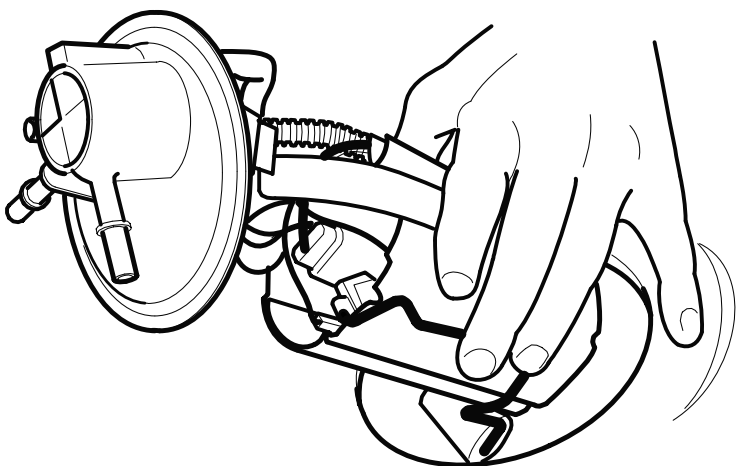

Install the right-hand fuel pump and level sensor 11.

Check that the O-ring is correctly positioned.

Press down the right-hand tank unit so that the fuel line connections are pointing forward and to the right.

Tighten the screw. Tighten to 60 Nm.

Install the hoses on the fuel tank unit.

Wipe up any fuel spillage.

Position the wiring in the cut-out in the rubber ring.

Note! Check that the arrow on the cover is between the markings on the tank. If the arrow is outside the markings the fuel gauge sensor will give an incorrect value and the float may catch against the inner wall of the tank.

If the arrow on the cover is outside the markings: Slacken off the screw and adjust the position of the fuel tank unit. Tighten as above.

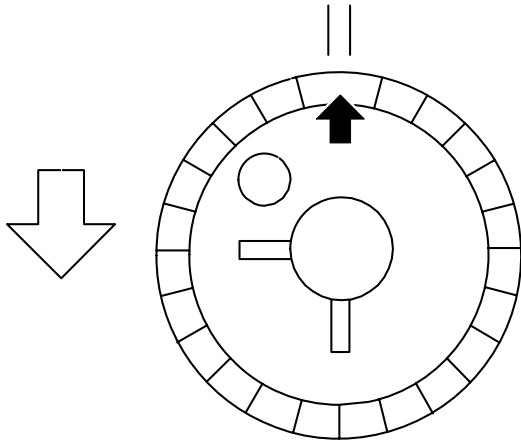

12.

Install the cover

Connect the wiring and connectors (3) to the fuel pump and the level sensor.

Install the cover (1 and 2) over the fuel tank units. Tighten the nuts.

Install the insulation panel.

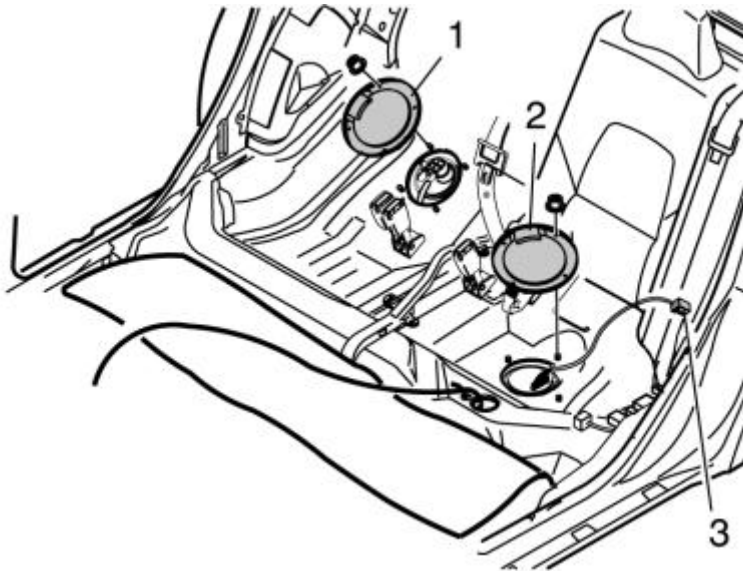

13.

Refilling with fuel

Start refilling the fuel that was drained from the tank.

Warning! Ensure that ventilation is good when filling the fuel.

VOLVO for life,
Volvo Cars of North America, LLC
Technical Engineering