



Volvo Cars of North America, LLC

1 Volvo Drive
P.O. Box 914
Rockleigh, NJ 07647
Phone: 201-768-7300
www.volvocars.us

March 18, 2010

TO: ALL U.S. RETAILERS
RE: FUEL PUMP RECALL 220

Volvo Cars of North America, LLC. (Volvo) has determined that a defect related to motor vehicle safety exists in the fuel pump of certain model year 2001-2005 S80, 2001-2004 S60, V70, V70XC/XC70 and 2003-2005 XC90 vehicles that were sold, or are registered in the states of Alabama, Arizona, Arkansas, California, Florida, Georgia, Hawaii, Kentucky, Louisiana, Mississippi, Nevada, New Mexico, North Carolina, Oklahoma, South Carolina, Tennessee, Texas, Utah, Virginia, District of Columbia and U.S. Territories.

If your customer has received a notification letter and does not currently reside in one of the States or U.S. Territories listed above, or if the vehicle is not part of the model years listed above, it is because our records indicate that the vehicle was originally sold in one of these States or U.S. Territories, or has been fitted with the concerned component and is eligible for this recall.

Volvo investigations have identified that a specific version of the fuel pump can when exposed to certain environmental conditions (hot climate and temperature cycling) over time and in combination of varying fuel quality, develop cracks in the fuel pump flange. If the condition occurs you may notice fuel smell and/or fuel seepage.

The corrective action will be to inspect the version of the fuel pump installed in your customer's vehicle, and if necessary replace the fuel pump with a part of a modified design.

OWNER NOTIFICATION

Recall Notice letters will be mailed in stages from March – June beginning with model year 2001. The first group of customer letters will be mailed by March 19th.

RETAILER RESPONSIBILITIES

Retailers must perform this recall on eligible vehicles regardless of miles/kilometers or vehicle age. All work performed under this recall is free of charge to the owner.

In the event that a customer does not have a notification letter, the owner is not to be refused the work.

Your regional representative will follow up to ensure that this recall is proceeding smoothly.

A complete description of the recall requirements and claim submission procedures is below. It is the retailer's responsibility to review the details provided in the materials listed below with all involved personnel.

- Service Manager Bulletin
- Retailer Tech Journal
- Parts Bulletin

Your cooperation in following the attached instructions for Recall 220 is greatly appreciated.

Drive Safely,

Volvo Cars of North America, LLC.

<h1 style="margin: 0;">VOLVO</h1> <h2 style="margin: 0;">Service Manager Bulletin</h2>				TITLE:		GROUP: 23	NO: 220A
				Recall 220: Fuel Pump Inspect & Replace if Necessary 2001-2005 S80, 2001-2004 S60, V70, V70XC/XC70, 2003-2005 XC90		ISSUING DEPARTMENT: Warranty	
REFERENCE BULLETINS: RTJ 22721 PB 23-220A		CARMARKET: United States					
		SERVICE PERSONNEL: read and initial.		DATE:		YEAR	MONTH
SERVICE MANAGER	SERVICE WRITER			WARRANTY ADMINISTRATOR	2010	07	28
Page 1 of 4							

*****UPDATE TO INFORMATION IN OWNER NOTIFICATION & RETAILER RESPONSIBILITY SECTIONS*****

- A. FUEL PUMP RECALL 220 DESCRIPTION
- B. VEHICLES INVOLVED
- C. PARTS INFORMATION/PARTS RETURN
- D. OWNER NOTIFICATION
- E. VEHICLES IN RETAILER INVENTORY
- F. RETAILER RESPONSIBILITY
- G. REIMBURSEMENT PROCEDURES
- H. TECHNICIAN COMPETENCY REQUIREMENT
- I. RETAILER ALLOWANCE

A. RECALL 220 DESCRIPTION

Volvo Cars of North America, LLC. (Volvo) has determined that a defect related to motor vehicle safety exists in the fuel pump of certain model year 2001-2005 S80, 2001-2004 S60, V70, V70XC/XC70 and 2003-2005 XC90 vehicles that were sold, or are registered in the states of Alabama, Arizona, Arkansas, California, Florida, Georgia, Hawaii, Kentucky, Louisiana, Mississippi, Nevada, New Mexico, North Carolina, Oklahoma, South Carolina, Tennessee, Texas, Utah, Virginia, District of Columbia and U.S. Territories.

If a vehicle owner has received this letter and does not currently reside in one of the States or U.S. Territories listed above, or if the vehicle is not part of the model years listed above, it is because our records indicate that the vehicle was originally sold in one of these States or U.S. Territories, or has been fitted with the concerned component and is eligible for this recall.

"Fixed Right — First Time"



Volvo investigations have identified that a specific version of the fuel pump can when exposed to certain environmental conditions (hot climate and temperature cycling) over time and in combination of varying fuel quality, develop cracks in the fuel pump flange. If the condition occurs you may notice fuel smell and/or fuel seepage.

The corrective action will be to inspect the version of the fuel pump installed in the vehicle per the instructions in RTJ 22721, and if necessary replace the fuel pump with a part of a modified design.

B. VEHICLES INVOLVED

NOTE: RETAILER MUST CONFIRM VEHICLE ELIGIBILITY PRIOR TO BEGINNING REPAIR FOR THIS CAMPAIGN.

Vehicle eligibility must be confirmed:

- Recall 220 owner notification letters will be mailed in stages from March - June. Vehicles will be marked eligible for Recall 220 in stages from March - June when the owner notification letters are mailed.
- Prior to the Recall 220 Customer Notification letter mailings, eligible vehicles were marked for Fuel Pump Recall Advisory Extended Warranty P29075. In VRC2 Vehicle Inquiry the message “Fuel Pump Recall Advisory extwty (P29075)” appeared for these vehicles. When the customer Recall 220 Notification letter mailings are completed for all eligible vehicles in June, Recall Advisory Extended Warranty P29075 will be closed.
- **Vehicles with fuel pump replacements performed under the Recall Advisory Extended Warranty P29075 will be marked complete for Recall 220. No customer Recall 220 notification letters will be mailed to these vehicle owners.**

All vehicles should be checked for any other incomplete recalls, service campaigns or service upgrades. All open recall, service campaign or service action repairs should be completed.

RETAILER VEHICLE CAMPAIGN LIST

A “Retailer Campaign List” will be posted on VRC² in the Reports Menu under the Service Tab when the Recall Notice letter mailing is completed. This list details all affected vehicles that are on record as being retailed or currently in stock at your facility, and is updated monthly. Vehicle eligibility must be confirmed via VRC² prior to performing a repair under the Recall Advisory Extended Warranty.

C. PARTS INFORMATION / PARTS RETURN

Fuel Pumps will be requested to be held for 30 days from payment date for Volvo representative inspection.

D. OWNER NOTIFICATION

Recall Notice letters will be mailed in stages from March 2010 – June 2010 beginning with model year 2001 vehicles.

Owners will be informed that actions performed under ANY recall will be completed at no charge.

E. VEHICLES IN RETAILER INVENTORY

All vehicles in retailer inventory that qualify for this recall must be repaired prior to a customer taking possession of the vehicle.

F. RETAILER RESPONSIBILITY

Retailers are to perform this recall on eligible vehicles regardless of mileage/kilometers or vehicle age. The repair work covered under Recall 220 is **free of charge** to the vehicle owner. This includes determination of vehicle eligibility and/or verifying the quality of work after the recall is completed.

If a customer presents a Recall Notice letter for a vehicle that is not found via the VRC² inquiry function, please verify that the letter applies to the customer's vehicle and call the Warranty Assistance Desk at 1-800-807-7712 for instructions. If the Warranty Assistance Desk verifies that the vehicle qualifies for the recall, please perform the repair and place the Recall Notice letter in the customer's file. Under no circumstances should a customer be denied the required service without a confirmation from VCNA/VCCL.

G. REIMBURSEMENT PROCEDURES FOR CUSTOMERS WHO PREVIOUSLY PAID FOR THIS REPAIR

Customers send the **repair order** with a **copy of the customer letter** to:
Volvo Recall 220 Reimbursement
c/o The Advertising Checking Bureau, Inc.
P.O. Box 1919
Memphis, TN 38101

- To avoid delays do not send this information to any other location.
 - The repair order must show that the customer previously paid for a fuel pump repair with the symptoms described in this bulletin, and include the amount paid, the date of payment, and the customer's name and address. If the repair order does not include the vehicle's VIN number, the customer should provide some other documentation reflecting that number, or simply write that VIN number onto the repair order.
- Customers can call 866-637-3774 to check on the status of their claim.
- Please allow 8 weeks for reimbursement.

H. TECHNICIAN COMPETENCY REQUIREMENT

The technician competency requirement for this campaign repair is: Level 2.

I. RETAILER ALLOWANCE AND CLAIM SUBMISSION (LONG FORM APPLICATION)**REPAIRS PERFORMED UNDER THE RECALL ADVISORY EXT WARRANTY**

Claim type:	R29076
Main Operation Number:	23293 or 23294
Failed Part Number:	30761742, 30761743, 30761744, 31273510
Cause Code:	02
CSC Code:	XW

FUEL PUMP CHECK & REPLACEMENT IS NOT NECESSARY

<u>Operation Number</u>	<u>Repair Description</u>	<u>Qty</u>		<u>Time</u>
23293	Inspect Fuel Pump Version	1	S60, V70, S80	0.8
			XC90 5 Seat	0.7
			XC90 7 Seat	1.4
			S80 Executive	1.3

FUEL PUMP CHECK & REPLACEMENT IS NECESSARY**(Both Operations Below Apply)**

<u>Operation Number</u>	<u>Repair Description</u>	<u>Qty</u>		<u>Time</u>
23293	Inspect Fuel Pump Version	1	S60, V70, S80	0.8
			XC90 5 Seat	0.7
			XC90 7 Seat	1.4
			S80 Executive	1.3
23294	Fuel Pump Replace	1	S60, V70, S80	0.9
			XC90 5 Seat	1.5
			XC90 7 Seat	0.9



Nothing can replace them.

Parts Bulletin

SUBJECT Recall 220: Fuel Pump Inspect & Replace if Necessary – 2001-2005 S80, 2001-2004 S60, V70, V70XC/XC70, 2003-2005 XC90				GROUP 23		NO 220A	
				MARKET United States		PAGE 1 of 2	
COPY TO / CIRCULATIONS (PLEASE INITIAL)							
GENERAL MGR	PARTS MGR	SERVICE MGR	SALES MGR	DATE	YEAR	MONTH	DAY
					2010	03	18

NOTE: PARTS WILL NOT BE ALLOCATED FOR THIS RECALL

Reference Bulletins: **SMB 23-220A**
RTJ 22721

Volvo Cars of North America, LLC. (Volvo) has determined that a defect related to motor vehicle safety exists in the fuel pump of certain model year 2001-2005 S80, 2001-2004 S60, V70, V70XC/XC70 and 2003-2005 XC90 vehicles that were sold, or are registered in the states of Alabama, Arizona, Arkansas, California, Florida, Georgia, Hawaii, Kentucky, Louisiana, Mississippi, Nevada, New Mexico, North Carolina, Oklahoma, South Carolina, Tennessee, Texas, Utah, Virginia, District of Columbia and U.S. Territories.

If a vehicle owner is receiving this letter and does not currently reside in one of the States or U.S. Territories listed above, or if the vehicle is not part of the model years listed above, it is because our records indicate that the vehicle was originally sold in one of these States or U.S. Territories, or has been fitted with the concerned component and is eligible for this recall.

Volvo investigations have identified that a specific version of the fuel pump can when exposed to certain environmental conditions (hot climate and temperature cycling) over time and in combination of varying fuel quality, develop cracks in the fuel pump flange. If the condition occurs you may notice fuel smell and/or fuel seepage.

The corrective action will be to inspect the version of the fuel pump installed in the vehicle per the instructions in RTJ 22721, and if necessary replace the fuel pump with a part of a modified design.

(See page 2 for part numbers.)

"Fixed Right — First Time"



Printed in USA on recycled paper containing a minimum of 50% wastepaper and 10% post-consumer waste.

© 2010 VOLVO CARS OF NORTH AMERICA, LLC

SUBJECT Recall 220: Fuel Pump Inspect & Replace if Necessary, 2001-2005 S80, 2001- 2004 S60, V70, V70XC/XC70, 2003-2005 XC90	GROUP 23	NO 220A	DATE 2010-03-18	PAGE 2 of 2
--	---------------------------	--------------------------	----------------------------------	------------------------------

The following part numbers apply:

Part Number	Description	Qty
30761742	Pump Unit	1
30761743	Pump Unit	1
30761744	Pump Unit	1
31273510	Pump Unit	1
9183708	O-Ring	2
985719	Flange Screw (XC90)	12
987891	Flange Lock Nut (non XC90)	1
986503	Washer (non XC90)	1
985055	Flange Screw (non XC90)	1
985047	Flange Screw (non XC90)	1

- There will not be an allocation of parts sent to your Retail facility.
- Please only order these parts based on the determination that this repair is necessary, after receiving a request from a customer to schedule a service appointment.



TIE - Technical Journal

Title Recall 220 Fuel pump inspection/replacement**Ref No** US22721.1.4 en-US**Issuer** -**Partner** 3 US 7510 Volvo Cars North America**Func Group** 2331 **Func Desc** fuel pump; feed pump**Status** Released**Status Date** 2010-12-06**Issue Date** 2010-12-02**Reference** VIDA**Attachment**

File Name	File Size
RTJ 22721 New version final 12-2-10.pdf	1.0537 MB

Vehicle Type

Type	Eng	Eng Desc	Sales	Body	Gear	Steer	Model Year	Plant	Chassis range	Struc Week Range
184	59	B5254T2					2004 -2004		0335000 -0392245	0 -0
184	91	B6294T					2002 -2005		0240000 -0406781	0 -0
275	59	B5254T2					2003 -2004		0000690 -0134088	0 -0
275	91	B6294T					2003 -2005		0000690 -0188345	0 -0
285	52	B5254T4					2004 -2004		0349000 -0459385	0 -0
285	59	B5254T2					2003 -2004		0286000 -0348999	0 -0
285	59	B5254T2					2003 -2004		0095000 -0173073	0 -0
285	61	B5244S					2001 -2002		0071747 -0285999	0 -0
285	61	B5244S					2001 -2002		0064306 -0285999	0 -0
295	59	B5254T2					2003 -2004		0095000 -0173073	0 -0
384	52	B5254T4					2004 -2004		0315000 -0425139	0 -0
384	59	B5254T2					2003 -2004		0235000 -0425139	0 -0
384	61	B5244S					2001 -2002		0006099 -0234999	0 -0

CSC

Code	Description
XY	Fuel system/Fuel leakage
A1	Fuel system/Fuel odor

DTC**Text****CSC = Customer Symptom Code****DTC = Diagnostic Trouble Code**

Note! If using a printed copy of this Retailer Technical Journal, first check for the latest online version.

Note: No additional vehicles have been added to this recall, the purpose of this update was to provide more defined pictures and chassis numbers to the vehicles involved.

NOTE! THIS DOCUMENT SUPERSEDES THE PREVIOUS RETAILER TECHNICAL JOURNAL *22721* DATED 10-05-2010. PLEASE UPDATE YOUR FILES.

IMPORTANT: The attached document contains instructions for all vehicles covered under this recall, Please note that some directions and parts are model and year specific.

** Updated information= A new leak detector (P/N 9512761) has been implemented in the fuel pump installation verification (step 34).*

DESCRIPTION:

Volvo Cars of North America, LLC. (Volvo) has determined that a defect related to motor vehicle safety exists in the fuel pump of certain model year 2001-2005 S80, 2001-2004 S60, V70, V70XC/XC70 and 2003-2005 XC90 vehicles that were sold, or are registered in the states of Alabama, Arizona, Arkansas, California, Florida, Georgia, Hawaii, Kentucky, Louisiana, Mississippi, Nevada, New Mexico, North Carolina, Oklahoma, South Carolina, Tennessee, Texas, Utah, Virginia, District of Columbia and U.S. Territories. Volvo investigations has identified that a specific version of the fuel pump can when exposed to certain environmental conditions (hot climate and temperature cycling) over time and in combination of varying fuel quality, develop cracks in the fuel pump flange. If the condition occurs you may notice fuel smell and/or fuel seepage.

SERVICE:

The corrective action will be to inspect the version of the fuel pump installed in the vehicle, and if necessary replace the fuel pump with a part of a modified design as described in the attachment.

Volvo Car Customer Service		
		Instruction
		TJ No.22721
		Reference VIDA Special Tool Bulletin 178
Title	Fuel pump, check/replacement	Page 1 of 21
Model	S60 / S80 (-06) / V70 (00-08) / V70 XC (01-)/XC70 (-07), engine B5254T2/T4, B5234T3, B5244T3, B5244S, B6284T, B6294T, B6294S/S2	
Model Year	2001-2005	

Material	Quantity	Part No.
Pump unit	1	30761742*
Pump unit	1	30761743*
Pump unit	1	30761744*
O-ring	2	9183708
Flange screw (seat back)	1	985047
Flange screw (mounting child seat)	1	985055
Flange lock nut (mounting child seat)	1	987891
Washer (mounting child seat)	1	986503
Lubricant	0.1	1161580**

* Depends on chassis number, see VIDA

** Standard material that should be available

Model	XC90, engine B5254T2, B6294T
Model Year	2003-2005

Material	Quantity	Part No.
Pump unit	1	30761742*
Pump unit	1	31273510*
O-ring	2	9183708
Flange screw	12	985719
Lubricant	0.1	1161580**

VOLVO

* Depends on chassis number, see VIDA

** Standard material that should be available

Special tools	Part No.
Leak tester	9512761
Fuel tank drainer	9814070▫
Adapter	9995480
Adapter	9995484
Wrench	9995720
Adapter	9995721
Wrench	9997314

▫ Or alternative draining equipment

Note! Some variation in the illustrations may occur, but the essential information is always correct.

Note! Exposing steps in this procedure may contain installation details.

1.

Preparations

Note! Ensure that nobody can insert the ignition key during work.

Remove the key from the ignition.

Note! In order to carry out this action in the most efficient way, the fuel pump check should start with draining the fuel tank in accordance with the stated procedure, parallel with the fuel pump checking procedure.

2.

Safety precautions for handling fuel

Warning! Avoid ignition sources.

Use breathing protection, type A/brown (organic substances) filter mask when there is a risk of breathing in fuel vapours.

Use protective gloves to avoid skin contact with fuel.

Ensure that there is good ventilation when draining and filling fuel.

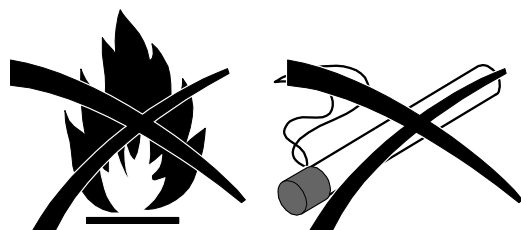

H8702135

3.

Draining the fuel tank

Insert the heavy duty hose 1.3 m into the fuel filler pipe, measured from the edge of the opening of the filler pipe.

Connect to the relevant draining equipment.

Pump until air comes out.

Warning! Ensure that ventilation is good when draining the fuel.

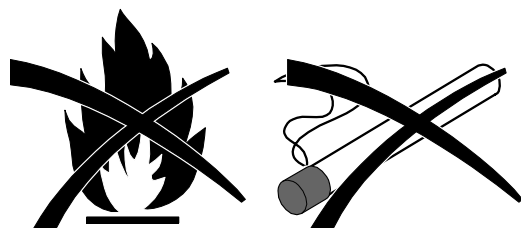

H8702135

4.

Identifying

The fuel pumps occur in five different versions. Two out of the five are defective.

Note! Only the illustrated fuel pump versions are allowed.

5.



The pump flange is **white** with a smooth surface (except for the connections).

Note! This pump is defective and must be replaced.

6.

Identifying

The pump flange is **white**

Note! This pump is defective and must be replaced.



7.

The pump flange is **white** with a cavity cast in the flange.

Note! This pump is correct.



8.

The pump flange is **yellow**.

Note! This pump is correct.

Note!
All fuel pumps with yellow flange are correct. The yellow flanged pump may come with or without electrical connector pins.



Exposing for checking**S60/S80**

Remove the seat cushion

Fold the front section of the cargo compartment to one side.

Remove the mounting for the child seat.

Screw M12. Torque 40Nm.

Nut M10. Torque 30Nm.

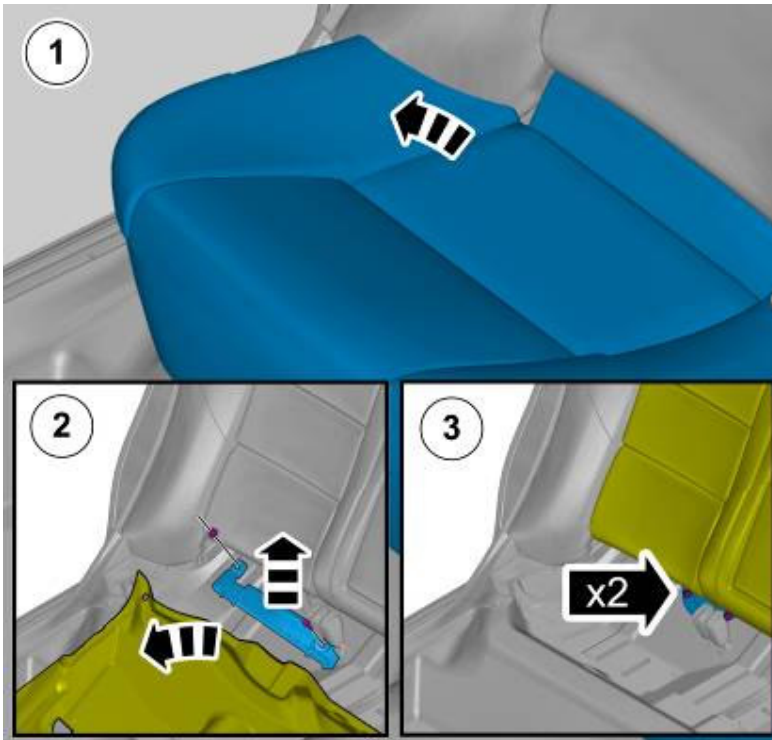

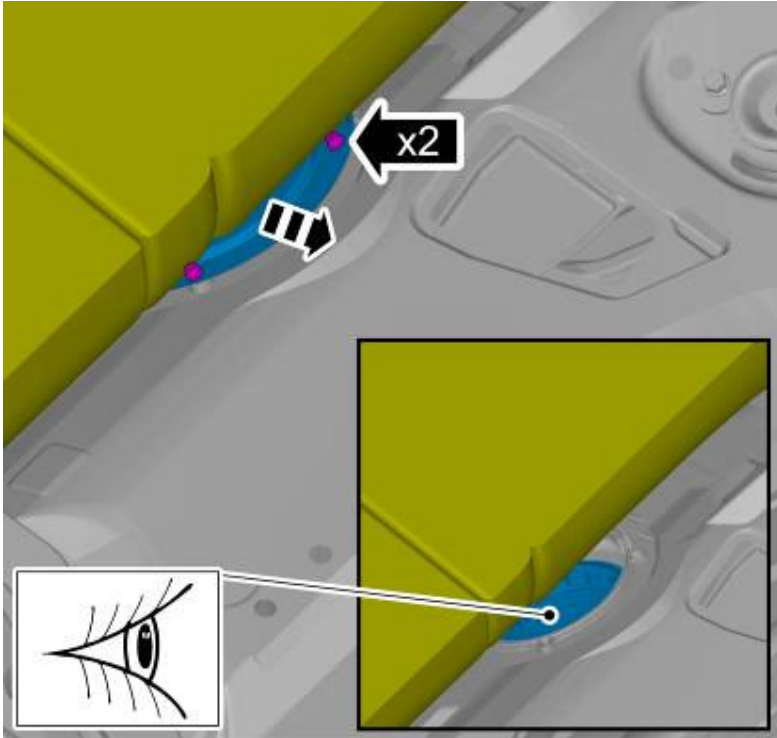

Fold the insulation mat to one side

Remove the cover from above the fuel pump.

Nut M6. Torque 6 Nm.

Check the fuel pump version.

If the check reveals that the pump is the correct version, start resetting by refilling with fuel.

Perform general resetting in reverse order.

Caution! Make sure that new screws and nuts are installed

If the check reveals that the fuel pump must be replaced, carry out work according to these instructions.

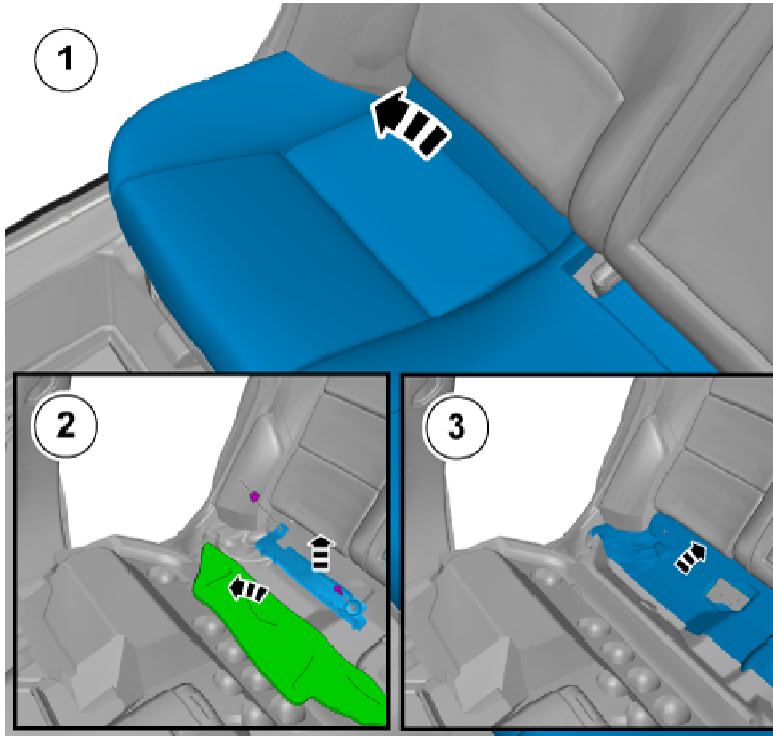
Exposing for checking**V70/XC70**

Fold the seat cushion forward.

Remove the cargo compartment floor.
Applies to vehicles (5 seats).

Only applies to vehicles with extra seat, remove the front section of the floor in the cargo compartment.

Remove the mounting for the child seat.

Screw M12. Torque 40 Nm.

Nut M10. Torque 30Nm.

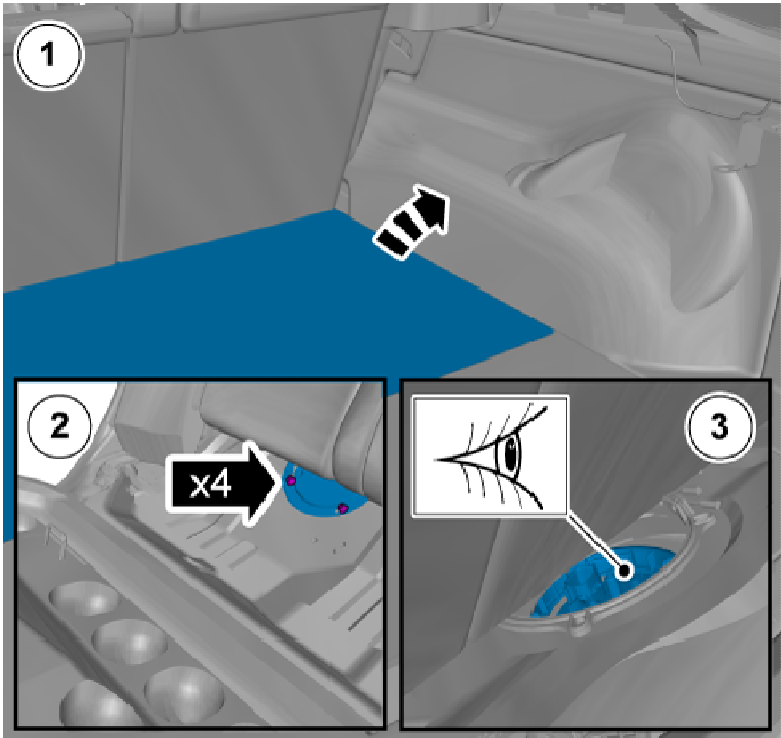

Fold the insulation mat to one side.

Remove the cover from above the fuel pump.

Nut M6. Torque 6 Nm.

Check the fuel pump version.

If the check reveals that the pump is the correct version, start resetting by refilling with fuel.

Perform general resetting in reverse order.

Caution! Make sure that new screws and nuts are installed

If the check reveals that the fuel pump must be replaced, carry out work according to these instructions.

Exposing for checking

XC90 5 seats

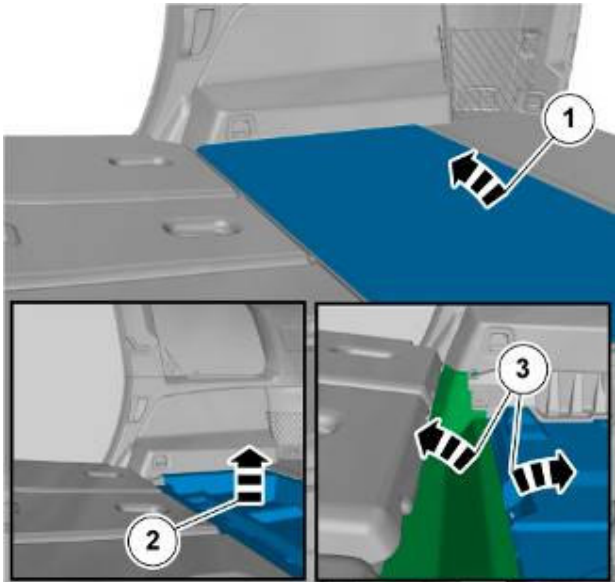

Fold the right rear backrest forward.

Remove the front part of the cargo compartment floor.

Fold the mat to one side at the front of the cargo compartment.

14.

Remove the cover from above the fuel pump.

Nut M6. Torque 6 Nm.

Check the fuel pump version.

If the check reveals that the pump is the correct version, start resetting by refilling with fuel.

Perform general resetting in reverse order.

If the check reveals that the fuel pump must be replaced, carry out work according to these instructions.

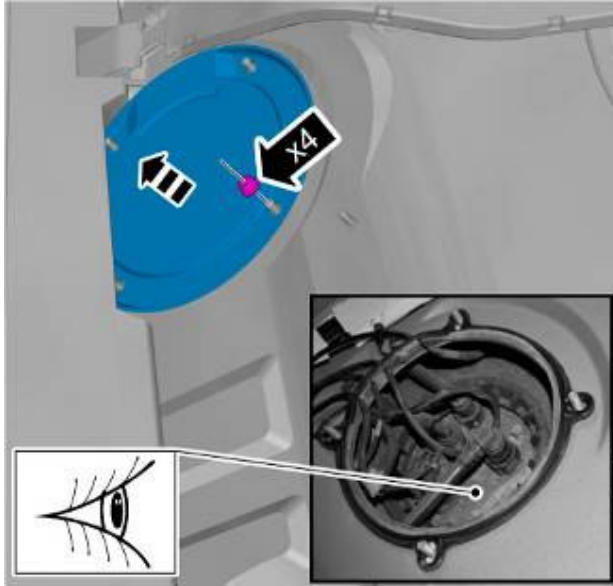

15.

Exposing for checking

XC90 7 seats

Fold up the backrest for the third row of seats.

Remove the second row of seats.

Screw M10. Torque 50 Nm.

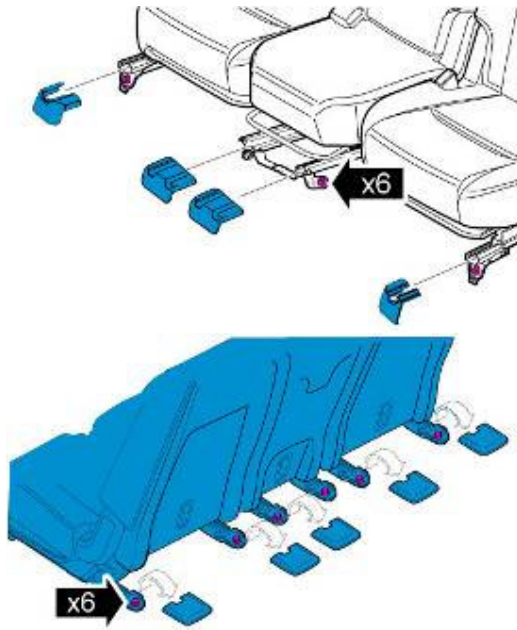

16.

Exposing for checking

Fold aside the floor mat.

Remove the insulation block.

Remove the air duct.

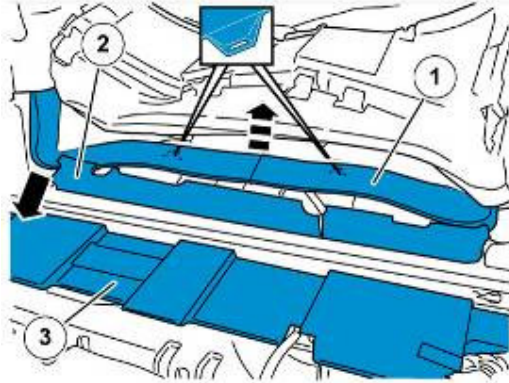

17.

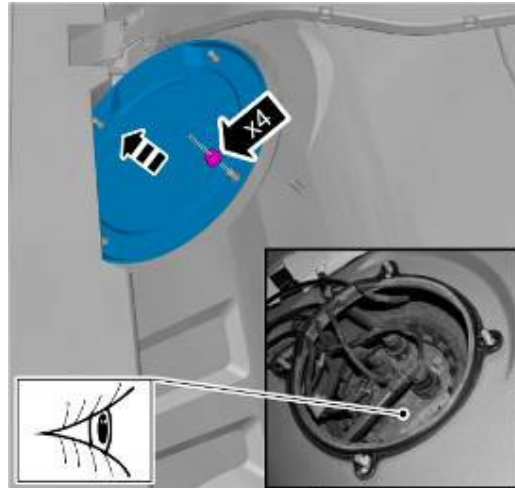

Remove the cover from above the fuel pump.

Nut M6. Torque 6Nm.

Check the fuel pump version.

If the check reveals that the pump is the correct version, start resetting by refilling with fuel

Perform general resetting in reverse order.

Caution! Make sure that new screws are installed

If the check reveals that the fuel pump must be replaced, carry out work according to these instructions.

18.

Fuel pump replacement

Note! Replace the fuel pump from the point where the check of the fuel pump identity finished.

19.

Draining the fuel lines

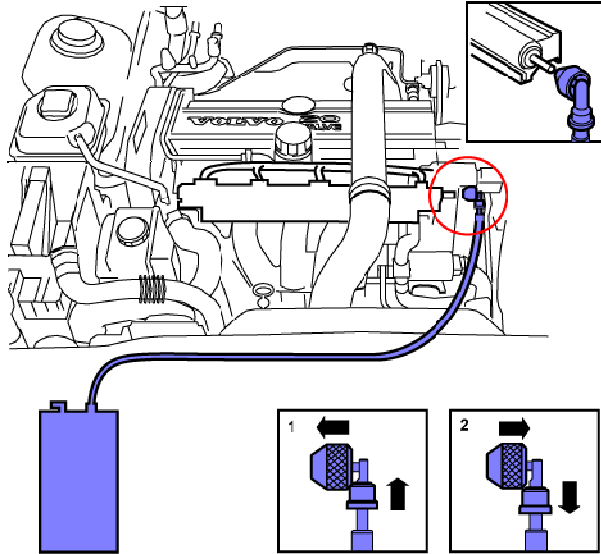

Remove the protection on the valve located on the fuel rail.

Connect adapter **9995484** to the draining equipment **9814070** (or similar specification).

Connect the adapter to the valve on the fuel rail in the locked position (image 1 = valve closed).

Start the draining equipment.

Release the adapter (image 2 = valve open).

Raise the vehicle.

IMG-297983

20.

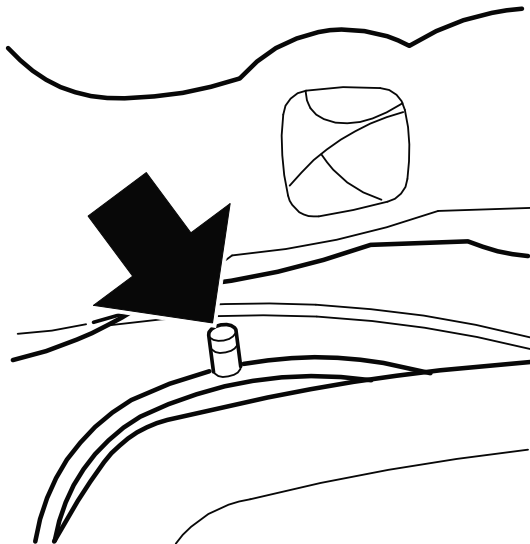

Remove the protection on the valve located on the fuel filter.

For easier access, remove the right-hand rear wheel.

Connect bleed hose **9995480** to the valve before the fuel filter.

It takes approximately 2 minutes to drain the lines.

D2302383

21.

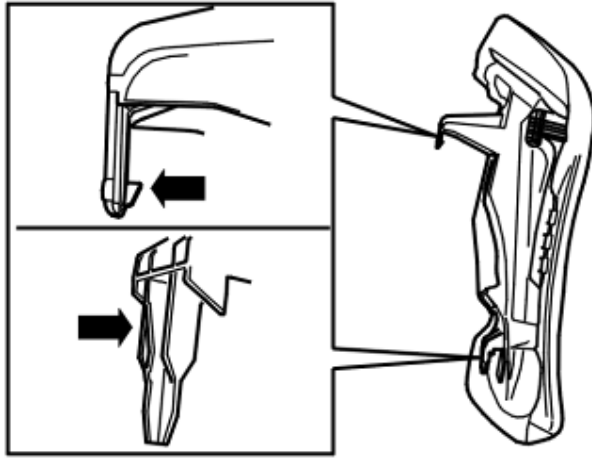

Remove the right-hand side cushion, see illustration.

Insert a hand between the mounting and the wheel arch panel and press in the catch. With the other hand, press in the upper mounting's catch towards the panel and press the bolster upwards.

D8505308

22.

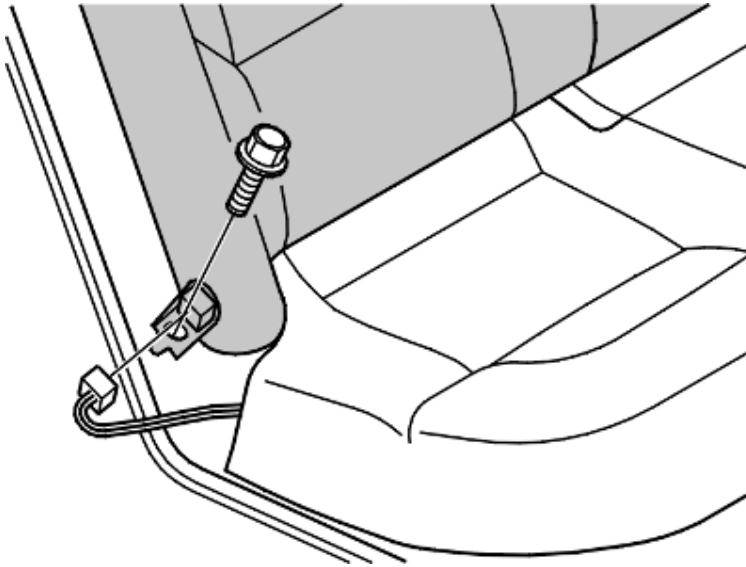

Disconnect the connector at the hinge on the right-hand side.

Remove the screw on the mounting for the hinge on the right-hand side.

Lift the backrests out.

D8505309

23.

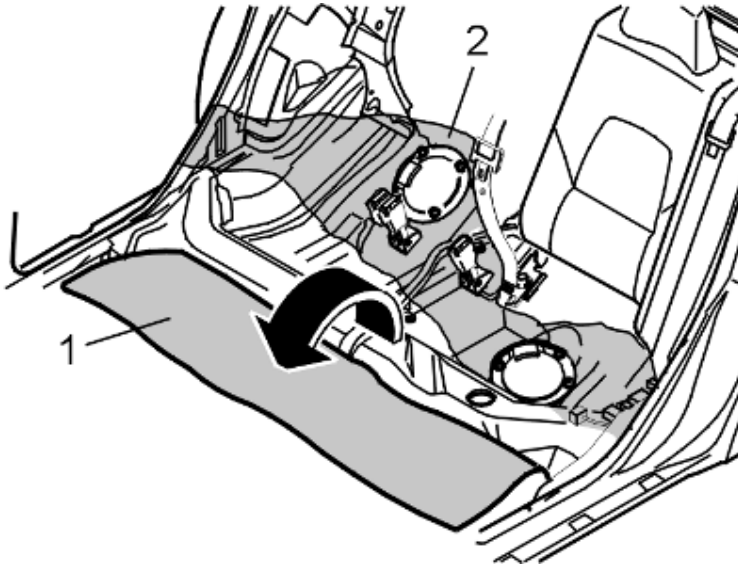

Push the carpet (1) to one side.

Remove the insulation panel.

Cover the area (2) around the cover and between the doors with absorbent material.

Caution! Ensure that dirt does not enter the tank.

D2302555

24.

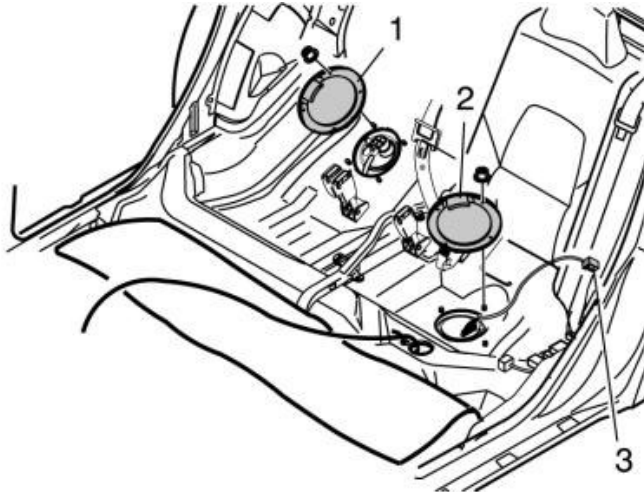

Remove the cover (2) from over the tank units.

Detach the left-hand fuel tank unit's connector (3). (Certain models only)

Detach the right-hand fuel tank unit's connector. (Certain models only)

Remove the hoses from the right-hand fuel tank unit.

IMG-300603

25.

Draining the fuel tank

Use wrench **9995720**.

Clean and remove all dirt at the right and left-hand fuel tank units.

Open the right-hand fuel tank unit. Insert the thick hose, see image, and draw up the remaining fuel from the bottom of the right-hand side of the tank.

Connect hose **9995721** to the heavy duty hose. Suck out the remaining fuel from the bottom of fuel tank unit reservoir.

Warning! Ensure that ventilation is good when draining the fuel.

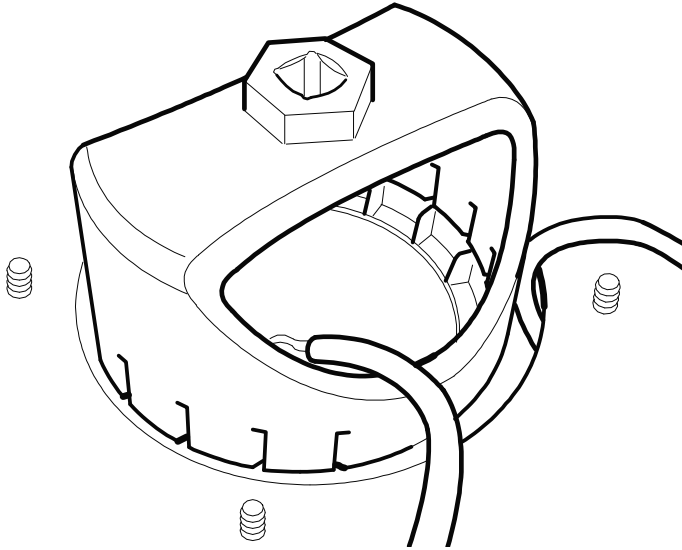

D2302302

26.

Carefully detach the overflow pipe from the reservoir.

Connect the hose from the draining unit to the overflow pipe using a hose clamp.

Pump until air comes out.

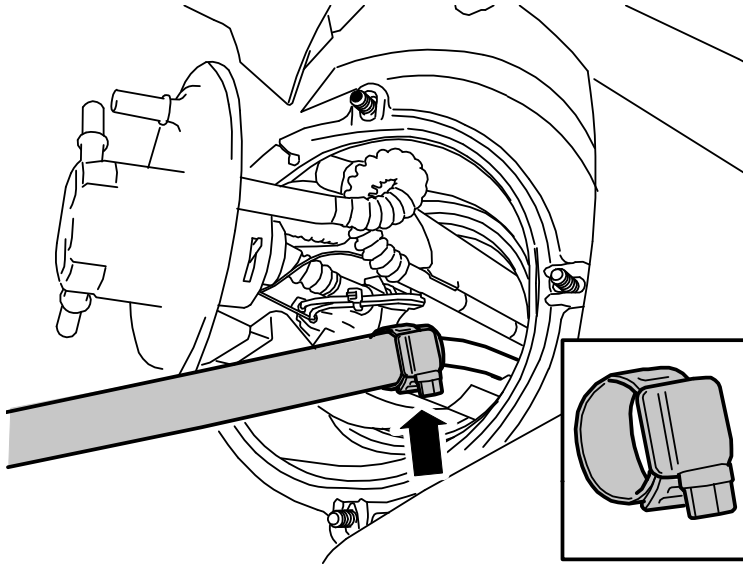

D2303517

27.

Fuel pump replacement

Use wrench **9995720**.

Open the left-hand fuel tank unit.

Remove:

- the two connectors from the underside of the left-hand level sensor
- left-hand level sensor from its underlying ejector

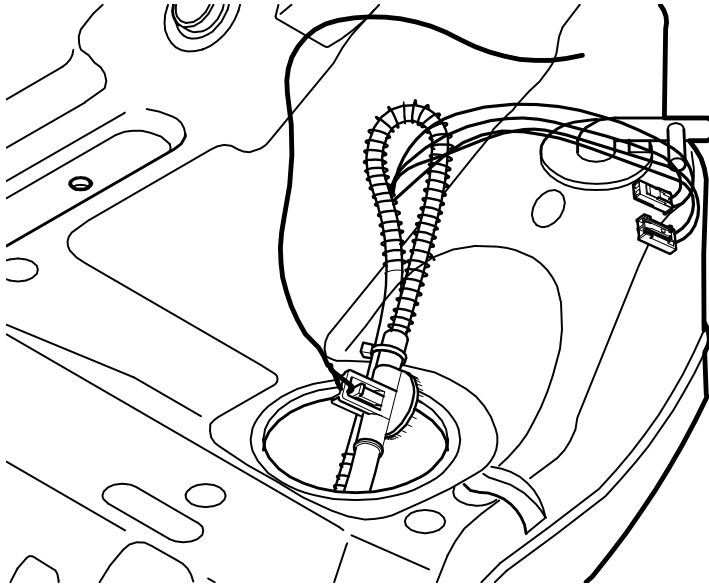

Note! Secure a wire in the area of the ejector.

The wire must be sufficiently long that it reaches over to the opposite side of the tank with some excess remaining to ensure that it does not slide into the tank.

The wire is needed to pull the hoses and wiring back to the left-hand side of the tank after the fuel tank unit has been replaced.

D2302209

28.

Removal of the right-hand fuel pump and level sensor

Grip the holder to the right of the fuel pump and level sensor. Pinch the float in its lowest position.

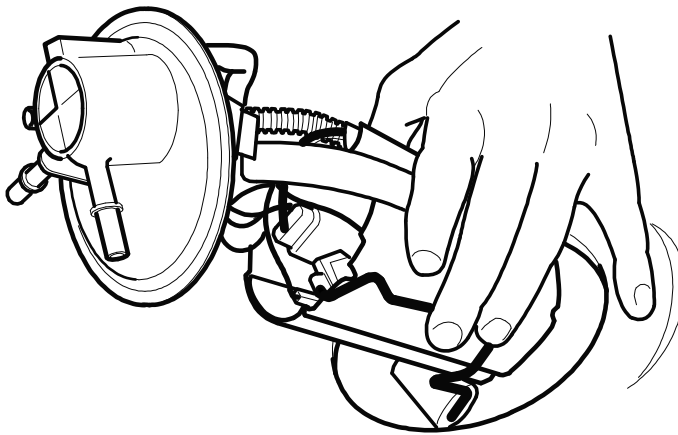

D2302303

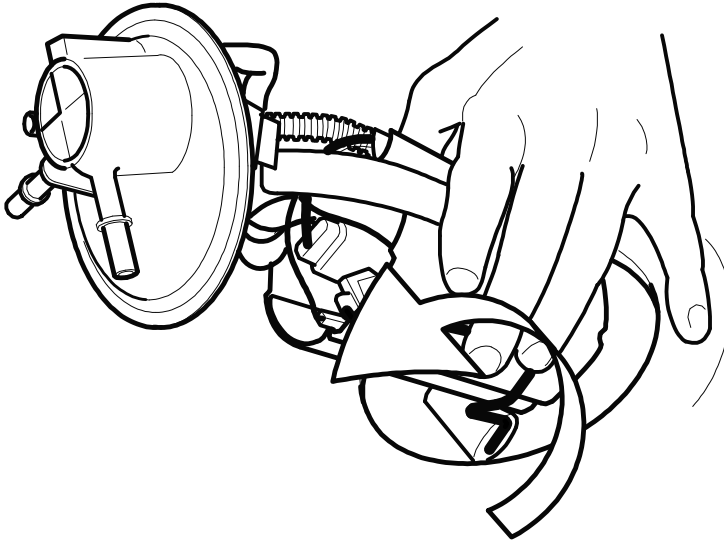

Warning! Take care with fuel spillage.

Carefully and slowly pull up the reservoir. Carefully work it out.

Pull the hoses out from the tank without pulling up the entire wire from the right-hand hole in the tank.

Caution! It is important that the float arm is not broken or bent.

Remove the wire from the ejector for the old fuel pump and level sensor.

Remove the o-rings for the left and right fuel pump and level sensor.

Clean the seats of the level sensors by sucking up any contaminants.

D2302305

Install the right-hand fuel pump and level sensor and left-hand level sensor in the tank.

Note! Applies to vehicles with parking heater.

Drill out the hole connection in the fuel tank unit.

Use a 4 mm drill bit. Transfer the dip stick.

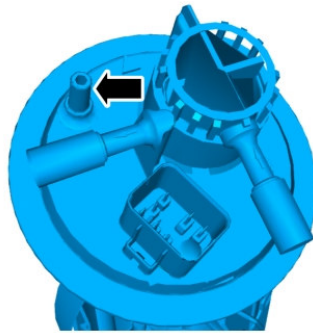

V002271

31.

Install the right-hand fuel pump and level sensor and left-hand level sensor in the tank.

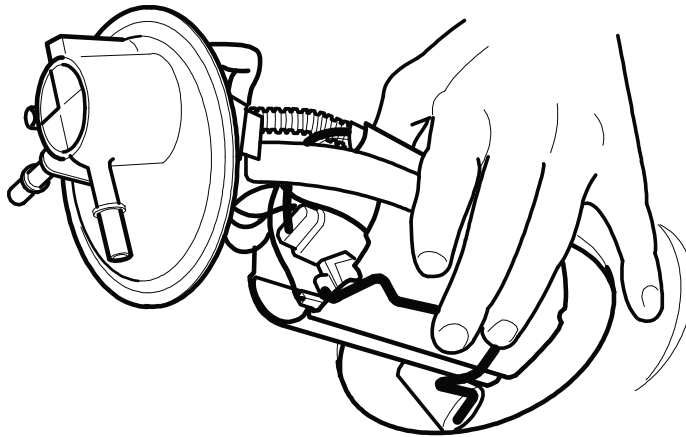

Lubricate the new O-rings with lubricant (see the materials list) and install them.

Install the wire on the new fuel pumps and level sensor's ejector.

Insert the hoses and lines into the tank via the right tank hole.

Grip the right-hand level sensor and fuel pump holder and pinch the float in its lowest position.

Carefully and slowly lower the reservoir. Carefully work the reservoir into place.

Pull the wire so that the hoses and wiring end up on the left side of the tank.

Install the:

- left-hand level sensor on the ejector
- the connectors on the underneath of the left-hand level sensor

Remove the wire from the ejector.

D2302303

32.

Install the right-hand fuel pump and level sensor

Check that the O-ring is correctly positioned.

Press down the right-hand tank unit so that the fuel line connections are pointing forward and to the right.

Tighten the screw. Tighten to 60 Nm.

Install the hoses on the fuel tank unit.

Wipe up any fuel spillage.

Position the wiring in the cut-out in the rubber ring.

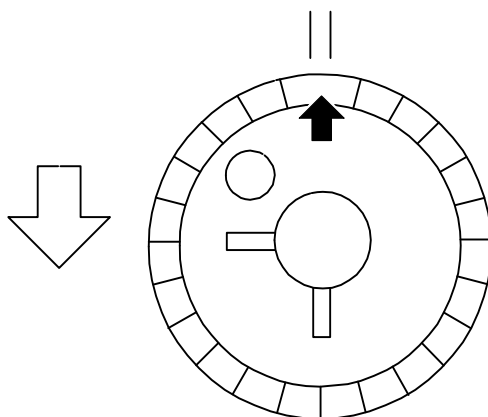

D2302323

Note! Check that the arrow on the cover is between the markings on the tank. If the arrow is outside the markings the fuel gauge sensor will give an incorrect value and the float may catch against the inner wall of the tank.

If the arrow on the cover is outside the markings: Slacken off the screw and adjust the position of the fuel tank unit. Tighten as above.

33.

Install the left-hand level sensor

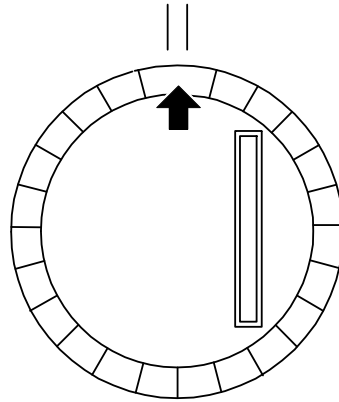

D2302925

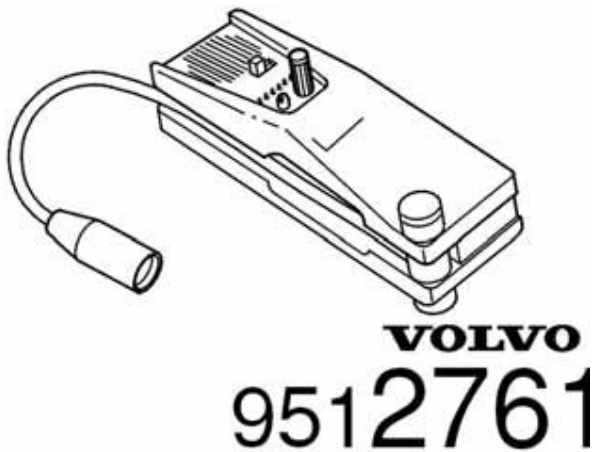

34.

Refilling with fuel

Start refilling the fuel that was drained from the tank.

Warning! Ensure that ventilation is good when filling the fuel.

Connect the wiring and connectors (3- see picture in step 35) to the fuel pump and the level sensor.

Start engine, run for 1 minute shut off and use leak tester to check all connections for any leaks.

Be sure to check around the lock ring on both the pump and left side level sensor.

35.

Install the cover

Install the cover (1 and 2) over the fuel tank units. Tighten the nuts.

Install the insulation panel.

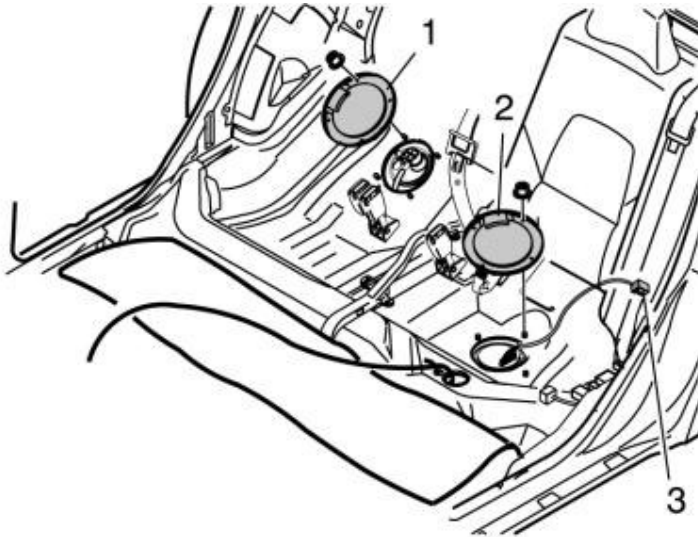

36.

Install the cushion

Install:

- The mounting to the child seat. Tighten the nut to 30 Nm and the screw to 40 Nm. Use new nut, washer and screw.
- Backrests. Use new screw. Tighten to 50 Nm
- the connector
- the side cushion
- the seat cushion

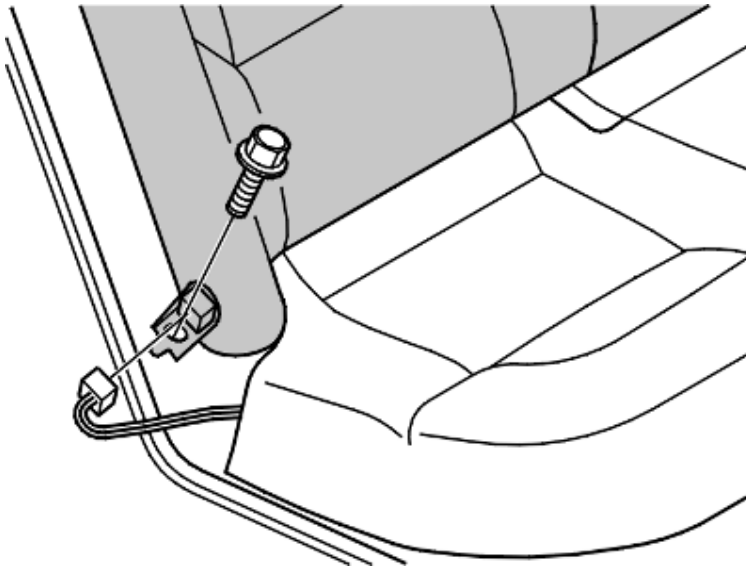

37.

Follow-up work

Test drive the vehicle.