

TOYOTA CUSTOMER SERVICES

Volume: XVI
Number: TC10-015
Date: 03/08/2010
 Action
 Retain
 Information

INTEROFFICE MEMORANDUM

To: All Region/Private Distributor General Managers/Vice Presidents

From: Bob Waltz, 
Vice President, Product Quality and Service Support

Subject: Safety Recall (Special Service Campaign) – 90M
Certain 2000 – 2003 Model Year Toyota Tundra Vehicle in Severe Cold Climate States
Excessive Corrosion of the Rear Cross Member (Spare Tire Carrier)

As announced on November 16, 2009, Toyota filed a Defect Information Report (DIR) with the National Highway Traffic Safety Administration (NHTSA) informing the agency of our intent to conduct a voluntary Safety Recall on certain 2000 - 2003 Model Year Toyota Tundra vehicles **currently registered in or originally sold in** specific Severe Cold Climate States listed below and the District of Columbia:

CT, DE, IL, IN, KY, MA, MD, ME, MI, MN, NH, NJ, NY, OH, PA, RI, VA, VT, WI & WV

A separate Special Service Campaign (SSC) 9SM will be launched covering all other 2000-2003 model year Tundra vehicles that were **originally sold in and currently registered in** the remaining 30 states. **Dealerships will receive a separate communication with respect to that SSC in the near future.**

Background

- On certain 2000 through 2003 model year Tundra vehicles operated in cold climate areas with high road salt use (*Severe Cold Climate States*) excessive corrosion may be exhibited on the rear cross-member of the frame. In the worst case, the spare tire stowed under the truck bed may become separated from the rear cross-member. Spare tire separation will create a road hazard for following vehicles and could cause a crash without prior warning. Eventually, excessive corrosion of the rear cross-member may also affect the functionality of the rear brake line at the proportioning valve. If this occurs, it can lead to the loss of the rear brake circuits, which will increase vehicle stopping distances and could cause a crash without prior warning.
- In addition, excessive corrosion may also be exhibited on the fuel tank mounting system, which includes two other cross-members and fuel tank straps. In the worst case, the fuel tank may drop to the ground and be dragged or separate from the vehicle. This may create a road hazard which could cause a crash without prior warning or possibly a fire.
- Exposure to cold climate and high road salt usage conditions are primary contributors. This is unrelated to, and separate from, normal surface rust which is commonly found on metallic surfaces after some years of usage and/or exposure to the environment.

The following vital information is provided to inform you and your staff of the owner notification phase of the campaign and your degree of involvement.

1. Dealer Letter Mailing Date

The attached Dealer Letter will be sent to all Toyota dealers in early March, 2010.

2. Owner Notification Letter Mailing Date

The owner notification will commence in mid-March, 2010, approximately one week after the dealer notification. The owner letters will be mailed out over approximately one month.

- Safety Recall Notices will be mailed to owners of Tundra vehicles **currently registered in** the 20 Severe Cold Climate States covered by the Safety Recall. A sample of this owner letter is included in this package.
- Owners whose vehicles were **originally sold in** one of those states but are now registered in another state will receive the Safety Recall Notice as well.

3. Number of Vehicles Involved

There are approximately 110,000 Toyota Tundra (model year 2000 – 2003) vehicles registered in or originally sold in the Severe Cold Climate States covered by this Safety Recall.

4. Region/District Summary Reports

The following Safety Recall 90M Summary Reports will be provided:

- Region/PD Summary Report that provides an overview of the entire Region/PD for this Safety Recall.
- A District Summary Report that indicates the number of involved vehicles per dealership in each district for this Safety Recall.

5. DSPM Support

Toyota is working quickly to ensure that sufficient quantities of replacement Rear Cross-Members and ancillary parts are available for this program. We understand there may be unique situations that require customers to be placed in rental vehicles (TRAC). In these special circumstances, we ask for DSPM support.

- If necessary, DSPMs are allowed to authorize vehicle rentals **exceeding** 30 days but no greater than 60 days based upon parts availability and repair capacity.
- If the customer has special vehicle requirements, DSPMs may authorize up to \$60.00 per day.

We greatly appreciate your support in reviewing and as necessary approving these requests.

Please review this entire package with your Service and Parts staff to familiarize them with the proper step-by-step procedures required to implement this Safety Recall.

- cc: Region/Private Distributor Assistant General Managers
Region/Private Distributor Customer Service Operations Managers
Region/Private Distributor Service Managers/Directors/VPs
Region/Private Distributor Parts Managers/Directors/VPs
Region/Private Distributor Customer Services Field Managers
Region/Private Distributor Technical Services and Training Managers
Region/Private Distributor District Service and/or Parts Managers
Region/Private Distributor Customer Relations Managers
Region/Private Distributor PDC Managers
Region/Private Distributor Field Technical Specialists
Region/Private Distributor Service Training Specialists
Region/Private Distributor Vehicle Operations Managers
All NAPC General Managers
All TMS Sales Administration Managers
All TMS Product Quality & Service Support Managers
All Field Product Engineers

- | | | | |
|--------------|---------------|----------------|---------------|
| J. Beseda | W. Fay | K. Kusakawa | S. Sugawara |
| G. Borst | N. Fein | M. Michels | M. Templin |
| R. Broughman | F. Fontanella | T. Morrison | J. Tetherow |
| G. Bryan | H. Fukui | T. Nakagami | P. Uribe |
| W. Burns | S. Haag | D. Pettitt | K. Ura |
| D. Camden | J. Hanson | R. Pflughaupt | A. Vaish |
| B. Carter | K. Higgins | C. Reynolds | R. Waltz |
| G. Christoff | C. Hostetter | C. Roberts | S. Yamaguchi |
| J. Colon | M. Hosoe | R. Sakai | M. Yamanami |
| B. Cooper | Y. Inaba | D. Sakakibara | N. Yamamoto |
| R. Daly | M. King | M. Setta | H. Yoshihashi |
| F. Davidson | J. Lang | A. Smith | D. Zellers |
| T. Doi | J. Lentz | R. Specht | |
| D. Esmond | E. Matsuda | J. Stempkowski | |

To: All Toyota Dealer Principals, Service Managers, Parts Managers

Subject: Safety Recall (Special Service Campaign) – 90M
Certain 2000 – 2003 Model Year Toyota Tundra Vehicle in Severe Cold Climate States
Excessive Corrosion of the Rear Cross Member (Spare Tire Carrier)

As announced on November 16, 2009, Toyota filed a Defect Information Report (DIR) with the National Highway Traffic Safety Administration (NHTSA) informing the agency of our intent to conduct a voluntary Safety Recall on certain 2000 - 2003 Model Year Toyota Tundra vehicles **currently registered in or originally sold in** specific Severe Cold Climate States listed below and the District of Columbia:

CT, DE, IL, IN, KY, MA, MD, ME, MI, MN, NH, NJ, NY, OH, PA, RI, VA, VT, WI & WV

A separate Special Service Campaign (SSC) 9SM will be launched covering all other 2000-2003 model year Tundra vehicles that were **originally sold in and currently registered in** the remaining 30 states. Dealerships ***will receive a separate communication with respect to that SSC in the near future.***

Background

- On certain 2000 through 2003 model year Tundra vehicles operated in cold climate areas with high road salt use (*Severe Cold Climate States*) excessive corrosion may be exhibited on the rear cross-member of the frame. In the worst case, the spare tire stowed under the truck bed may become separated from the rear cross-member. Spare tire separation will create a road hazard for following vehicles and could cause a crash without prior warning. Eventually, excessive corrosion of the rear cross-member may also affect the functionality of the rear brake line at the proportioning valve. If this occurs, it can lead to the loss of the rear brake circuits, which will increase vehicle stopping distances and could cause a crash without prior warning.
- In addition, excessive corrosion may also be exhibited on the fuel tank mounting system, which includes two other cross-members and fuel tank straps. In the worst case, the fuel tank may drop to the ground and be dragged or separate from the vehicle. This may create a road hazard which could cause a crash without prior warning or possibly a fire.
- Exposure to cold climate and high road salt usage conditions are primary contributors. This is unrelated to, and separate from, normal surface rust which is commonly found on metallic surfaces after some years of usage and/or exposure to the environment.

1. Owner Notification Letter Mailing Date

The owner notification will commence in mid-March, 2010, approximately one week after the dealer notification. The owner letters will be mailed out over approximately one month.

- Safety Recall Notices will be mailed to owners of Tundra vehicles ***currently registered in*** the 20 Severe Cold Climate States covered by the Safety Recall. A sample of this owner letter is included in this package.
- Owners whose vehicles were ***originally sold in*** one of those states but are now registered in another state will receive the Safety Recall Notice as well.

2. Number and Identification of Involved Vehicles

There are approximately 110,000 Toyota Tundra (model year 2000 – 2003) vehicles registered in or originally sold in the states covered by this Safety Recall.

MODEL	WMI	Year	VIN Range	
			VDS	Range
Tundra	5TB	2000	BN441	S001001 - S125840
			BN481	S001001 - S001001
			BT441	S001001 - S125901
			BT481	S001001 - S125894
			JN321	S001001 - S125878
			KN421	S001001 - S123980
			KN441	S001001 - S051314
			KT441	S001001 - S125833
			RN341	S001001 - S125859
			RN381	S001001 - S001003
			RT341	S001001 - S125904
			RT381	S001001 - S125897
		2001	BN441	S125937 - S220312
			BT441	S125905 - S220327
			BT481	S064335 - S220350
			JN321	S126112 - S220343
			KN441	S064852 - S064852
			KT421	S090565 - S217964
			KT441	S125921 - S220297
			RN341	S125909 - S220341
			RT341	S125907 - S220347
			RT381	S064333 - S220345
			BN441	S220394 - S332707
			BT441	S219294 - S332720
		2002	BT481	S219295 - S332685
			JN321	S220351 - S332714
			KT421	S220380 - S328382
			KT441	S220392 - S332706
			RN341	S220353 - S332719
			RT341	S220360 - S332721
			RT381	S220365 - S332666
			BN441	S332744 - S434010
			BT441	S316368 - S439612
			BT481	S306031 - S439613
			JN321	S332745 - S436914
			KT421	S332818 - S414089
		2003	KT441	S330788 - S439601
			RN341	S307943 - S436915
			RT341	S306032 - S439732
			RT381	S308386 - S439716

Please note that all vehicles that were **originally sold in or currently registered in** the covered states are eligible for this inspection and if necessary remedy at **no charge** regardless of the vehicle's age or mileage.

If your dealership is contacted by an owner who has not received a notification, please **verify eligibility by confirming through Dealer Daily/TIS prior to performing repairs**. Dealers should perform the inspection and if necessary repair as outlined in the Technical Instructions found on TIS.

3. Vehicles in Dealer Stock

Dealers are requested to perform the inspection and if necessary remedy on any vehicles currently registered in or originally sold in the 20 Severe Cold Climate States prior to delivery. Vehicle Safety Recall completion can be verified through TIS.

4. Dealer/Owner Lists

For your reference, the following summary reports are included for dealership Service and Parts Managers located in the **20 Severe Cold Climate States only**:

- **Dealer Reports will no longer contain a PMA VIN list.** However, they will contain the number of involved vehicles registered in each dealership's primary marketing area and initial suggested parts order quantities, where applicable.

Dealerships located in the remaining 30 states will not receive any reports.

5. **Parts Ordering**

Since not all vehicles will require cross-member and/or associated parts replacement, these parts will be placed on Manual Allocation Control (MAC).

While the parts are on MAC, a representative from TMS will review each order and contact the dealership's Parts Manager to verify the necessity of the order. This will assure an adequate and balanced parts inventory.

If there are special circumstances where a dealer is having difficulty receiving parts, dealership associates may contact (310) 468-5516 to research their order for the cross-member parts. The associate should have the following information ready to expedite research of the order status:

1. Dealer Information (Dealer Code, Contact Name, Telephone Number)
2. Order Reference Number
3. Customer Name and Vehicle 17-digit VIN

Please refer to the table below for rear cross member part numbers. Additional part number information can be found in the Technical Instructions (located on TIS). Parts can be ordered from your facing PDC.

- For 2000 – 2002 Model Year

Part Number	Part Description	Quantity
51209-0C010	Rear Frame Cross Member Sub-assembly	1
90080-11288	Bolt	13
90178-A0082	Nut	13

- For 2003 Model Year

Part Number	Part Description	Quantity
51209-0C012	Rear Frame Cross Member Sub-assembly	1
90080-11288	Bolt	13
90178-A0082	Nut	13



***Part replacement is based on inspection results. DO NOT order parts until the vehicle inspection has been completed. Refer to the Technical Instructions posted on TIS for additional part number information. In the event parts are not available, please refer to the Technical Instructions for specific criteria and handling. This includes making a rental vehicle available based upon the inspection results.**

IMPORTANT PARTS ORDERING REMINDER

Effective March 1, 2009, Safety Recall, Service Campaign (SSC/LSC) and Customer Support Program (CSP) parts do not earn Parts Return Credit Accrual and are not returnable under the Monthly Return Program. It is recommended that you order these parts based on appointments or immediate customer needs using a "Sell One-Buy One" ordering pattern. Please refer to PANT Bulletin 09-12 for additional details.

[Parts Ordering continued...]

This UIO matrix is provided to inform your dealership of the approximate number of vehicles in your state that are covered by this Safety Recall.

State	2000 MY	2001 MY	2002 MY	2003 MY	Total
CT	1017	675	840	804	3,336
DC	60	31	43	44	178
DE	250	130	163	173	716
IL	1,764	1,217	1,604	1,401	5,986
IN	1,461	844	1,207	1,114	4,626
KY	2,184	1,127	1,351	1,185	5,847
MA	2,661	1,864	2,415	2,482	9,422
MD	1,976	1,222	1,592	1,888	6,678
ME	916	606	782	774	3,078
MI	1,203	659	863	799	3,524
MN	1,389	957	1,367	1,135	4,848
NH	996	691	775	893	3,355
NJ	1,470	937	1,129	1,208	4,744
NY	2,202	1,508	1,818	1,958	7,486
OH	2,502	1,233	1,550	1,525	6,810
PA	3,003	1,775	2,090	2,096	8,964
RI	438	272	358	354	1,422
VA	3,667	2,251	2,885	2,987	11,790
VT	543	333	455	474	1,805
WI	1,689	967	1,348	1,216	5,220
WV	763	441	490	534	2,228
TOTAL	32,154	19,740	25,125	25,044	102,063

Additional information, including part number and ordering procedures on a Corrosion Resistant Compound application will be provided as preparations are completed.

6. Technical Instructions

Refer to TIS for Technical Instructions on inspection and if necessary replacement procedures for the Rear Cross-Member, rear brake line at the proportioning valve, spare tire carrier and fuel tank mounting system.

7. Customer Handling Process, if parts are not available for required repairs

- Toyota is working quickly to ensure that sufficient quantities of replacement Rear Cross-Members and ancillary parts are available for this program. We understand there may be unique situations that require case-by-case handling. In these special circumstances, please contact your DSPM. They will work with your dealership to resolve issues where possible before escalating the case.

8. Tools and Equipment

In a separate shipment in early March 2010, dealerships in CT, DE, IL, IN, KY, MA, MD, ME, MI, MN, NH, NJ, NY, OH, PA, RI, VA, VT, WI & WV were sent a Safety Recall 90M Campaign Tool. This shipment included the required Frame Expansion Bar.

The Safety Recall 90M Campaign Tool package is labeled with a fluorescent (green, orange, yellow or pink) label like the sample seen below for easy identification.

**ATTN: Service Manager
Safety Recall 90M
Campaign Tool**

The additional required tools and equipment are listed in the technical instructions found on TIS.

9. **Warranty Processor Instructions**

Please note the following for this campaign:

- This Safety Recall involves the inspection of the Rear Cross-Member, Brake Tube, LSPV, Spare Tire Carrier and Fuel Tank Strap, and if applicable the replacement of the aforementioned parts.

OPERATION FLOW CHART

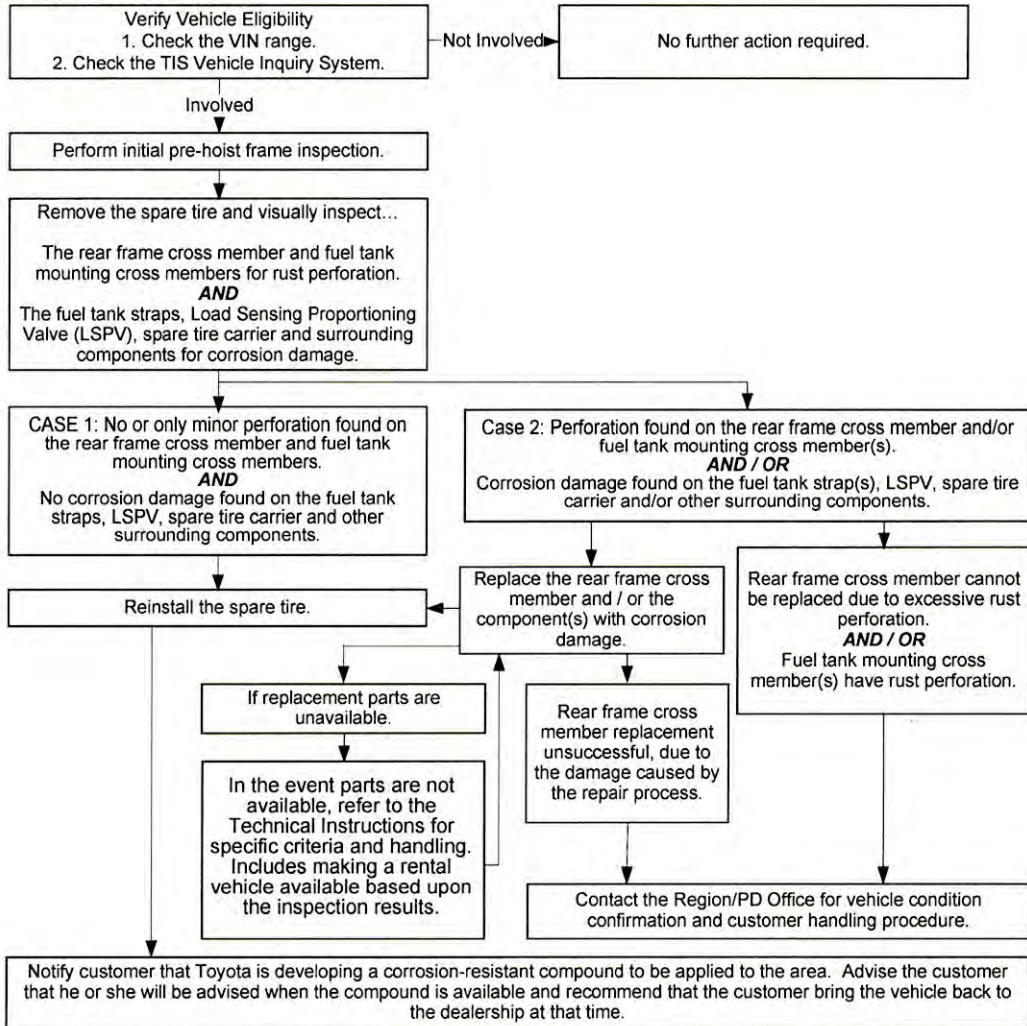

Submit Safety Recall claims following the procedures described in the Toyota Warranty Policy and Procedures Manual.

Part 1: Vehicle Inspection and Judgment Codes (Case 1 from Flowchart)

All inspection operation code (Op. Code) claims must be filed as a separate claim from the repair.

Safety Recall #	Op. Code	Description	Flat Rate Hour
90M	0505CA	Inspect the Rear Cross-Member and surrounding components (Brake Tube, LSPV, Fuel Tank Mounting System, Spare Tire Carrier, etc.) for Rust Perforation [No Rust Perforation and no surrounding component damage found (Case 1 shown in the Flow Chart)] NO PARTS REPLACEMENT REQUIRED	0.5 hr/vehicle
	0505CB	Inspect the Rear Cross-Member and surrounding components (Brake Tube, LSPV, Fuel Tank Mounting System, Spare Tire Carrier, etc.) for Rust Perforation [Rust Perforation and/or surrounding component damage found (Case 2 shown in the Flow Chart)] PARTS REPLACEMENT REQUIRED	0.5 hr/vehicle

NOTE: The above flat rate times includes 0.1 hour for administrative cost per unit for the dealership.

Part 2: Vehicle Repair Codes (Case 2 from Flowchart)

All inspection operation code (Op. Code) claims must be filed as a separate claim from the repair.

Choose one of appropriate operation code from the matrix on the next page according to the valuation and combination of necessary repair work(s) below.

[Warranty Processor Instructions continued...]

The following operation codes are only to be used in the event that the vehicle requires the replacement of the Rear Cross-Member, Fuel Tank Strap(s), Brake Tube, LSPV and Spare Tire Carrier. If these components can not be replaced, due to excessive rust perforation and/or the Fuel tank mounting cross member(s) have rust perforation contact your Region/Private Distributor Representative immediately.

Please indicate the corresponding Repair Work # (see table below) in the Condition Cause Remedy (CCR) section of the claim to signify which repairs were done based on the op. code as a cross-reference.

For example:

- If op. code 0506C7 (corresponding to Repair Work #'s 1, 3 and 4) is used. The CCR should state: "Repair Work #'s 1, 3, & 4."

Additional information, including operation codes for the Corrosion Resistant Compound application will be provided as preparations are completed.

Part 2: Vehicle Repair Codes (Continued – Case 2 from Flowchart)

Repair Work #	Description of Repair Work
1	Replace the rear cross member. This includes reinstalling the original or new spare tire carrier to the new rear cross-member
2	Replace the brake tube including air bleeding
3	Replace the LSPV including air bleeding
4	Replace the fuel tank strap(s)
5	Replace the spare tire carrier

Safety Recall/SSC #	Op. Code	Description (Affected Repair Work # above)					Flat Rate Hour
		1	2	3	4	5	
90M	0506C1	✓	-	-	-	-	5.0 hr/vehicle
	0506C2	✓	✓	-	-	-	5.5 hr/vehicle
	0506C3	✓	✓	✓	-	-	6.9 hr/vehicle
	0506C4	✓	✓	✓	✓	-	7.2 hr/vehicle
	0506C5	✓	✓	-	✓	-	5.8 hr/vehicle
	0506C6	✓	-	✓	-	-	6.6 hr/vehicle
	0506C7	✓	-	✓	✓	-	6.9 hr/vehicle
	0506C8	✓	-	-	✓	-	5.3 hr/vehicle
	0506C9	-	✓	-	-	-	0.5 hr/vehicle
	0506CA	-	✓	✓	-	-	1.9 hr/vehicle
	0506CB	-	✓	✓	✓	-	2.2 hr/vehicle
	0506CC	-	✓	✓	✓	✓	2.7 hr/vehicle
	0506CD	-	✓	✓	-	✓	2.4 hr/vehicle
	0506CE	-	✓	-	✓	-	0.8 hr/vehicle
	0506CF	-	✓	-	✓	✓	1.3 hr/vehicle
	0506CG	-	✓	-	-	✓	1.0 hr/vehicle
	0506CH	-	-	✓	-	-	1.6 hr/vehicle
	0506CJ	-	-	✓	✓	-	1.9 hr/vehicle
	0506CK	-	-	✓	✓	✓	2.4 hr/vehicle
	0506CL	-	-	✓	-	✓	2.1 hr/vehicle
0506CM	-	-	-	✓	-	0.3 hr/vehicle	
0506CN	-	-	-	✓	✓	0.8 hr/vehicle	
0506CP	-	-	-	-	✓	0.5 hr/vehicle	
0506CQ	Rear cross-member replacement unsuccessful, due to the damage caused by the repair process					3.0 hr/vehicle	

Note: For Operation Code 0506C1 through 0506C8 and 0506CQ which contain the cross-member replacement, \$8.00 per vehicle for the cost of the chisel cutter should be included on the SSC claim. Use "ZZ" sublet type. State "Chisel Cutter" in the sublet description. Sublet cost maximum is \$8.00.

Below is the "rental only" op. code which should be used for submitting rental claims. **Rental expense will be submitted separately from repair/replacement for this Safety Recall only and document attachments may be requested by the Warranty Department,**

SSC #	Op. Code	Description	Flat Rate Hour
90M	9502LL	Vehicle Rental 1-30 days	<i>Maximum \$35.00 per day</i>
	9502LM	Vehicle Rental 31-60 days <i>(Usage of this operation code requires DSPM Authorization)</i>	<i>Maximum \$35.00 per day</i>

Note: For Operation Code 9502LL, use "RT" sublet type. Special accommodations based upon customer needs, not outlined above require DSPM authorization.

Please review this entire package with your Service and Parts staff to familiarize them with the proper step-by-step procedures required to implement this Special Service Campaign.

Thank you for your cooperation.
TOYOTA MOTOR SALES, U.S.A., INC.

**SSC 90M – Certain 2000 through 2003 Tundra Vehicles
Severe Corrosion of the Rear Cross-Member
SAFETY RECALL NOTICE**

Dear Toyota Customer:

This notice is being sent to you in accordance with the requirements of the National Traffic and Motor Vehicle Safety Act. Toyota has decided that a defect, which relates to motor vehicle safety, exists in certain 2000 through 2003 model year Tundra vehicles.

What is the condition?

On certain 2000 through 2003 model year Tundra vehicles originally sold in and/or registered and operated in cold climate areas with high road salt use (*Severe Cold Climate States*), excessive corrosion may be exhibited on the rear cross-member of the frame. In the worst case, the spare tire stowed under the truck bed may become separated from the rear cross-member. Spare tire separation will create a road hazard for following vehicles and could cause a crash without prior warning. Eventually, excessive corrosion of the rear cross-member may also affect the functionality of the rear brake line at the proportioning valve. If this occurs, it can lead to the loss of the rear brake circuits, which will increase vehicle stopping distances and could cause a crash without prior warning.

In addition, excessive corrosion may also be exhibited on the fuel tank mounting system, which includes two other cross-members and fuel tank straps. In the worst case, the fuel tank may drop to the ground and be dragged or separate from the vehicle. This may create a road hazard which could cause a crash without prior warning or possibly a fire.

What will Toyota do?

Any Toyota Dealer will inspect the specified components and adjacent areas of your vehicle. Please see your dealership for details. Based upon the inspection, Toyota will do one or more of the following **at no charge** to you:

- If there is no significant corrosion of the cross-member assemblies, you will be notified of that fact and requested to subsequently bring your vehicle back to the dealership so that a corrosion-resistant compound can be applied to those assemblies. Toyota will notify you when the corrosion-resistant compound is available.
- If significant corrosion of the rear cross member is detected such that it can no longer safely support the spare tire, and replacement components are available, the cross-member assembly will be replaced.
- If the fuel tank straps exhibit deterioration, they will be replaced.

In those relatively rare cases where the rear cross-member is significantly corroded, but cannot be replaced due to excessive frame corrosion at the mounting location (e.g., if the side rails are too damaged), and/or if significant corrosion of either of the fuel tank cross members is detected, Toyota will provide an appropriate remedy on a case-by-case basis.

What should you do?

This is an important Safety Recall

Please contact your authorized Toyota dealer to make an appointment to have the inspection performed as soon as possible. The inspection will take approximately 30 minutes. If a rear cross member assembly is replaced at the time of this inspection, the repair will take approximately 8 hours. Moreover, depending upon the dealer's work schedule, it may be necessary to make your vehicle available for a longer period of time.

This Safety Recall involves customers whose vehicles are registered or originally purchased in the following 20 Severe Cold Climate States and the District of Columbia.

CT, DE, IL, IN, KY, MA, MD, ME, MI, MN, NH, NJ, NY, OH, PA, RI, VA, VT, WI & WV

We request that you present this notice to the dealer at the time of your service appointment.

If you would like to update your vehicle ownership or contact information, please go to www.toyota.com/ownersupdate. You will need your full 17-digit Vehicle Identification Number (VIN) to input the new information.

If you have moved to another state, but would like to have your vehicle inspected, please contact your local Toyota dealer and make an appointment. Toyota will perform the same inspection and, if necessary repair, at **no charge**. Please see your dealer for details.

What if you have other questions?

Your local Toyota dealer will be more than happy to answer any of your questions and set up an appointment to perform this important Safety Recall. If you require further assistance, you may contact the Toyota Customer Experience Center at 1-888-270-9371 Monday through Friday, 5:00 am to 6:00 pm, Saturday 7:00 am through 4:00 pm Pacific Time.

If you believe that the dealer or Toyota has failed, or is unable to remedy the defect within a reasonable time, you may submit a complaint to the Administrator, National Highway Traffic Safety Administration, 1200 New Jersey Avenue S.E., Washington, DC 20590 or call the toll free Vehicle Safety Hot Line at 1-888-327-4236 (TTY: 1-800-424-9153), or go to <http://www.safercar.gov>.

What if you have previously paid for repairs to your vehicle for this specific condition?

If you have previously paid for repair to your vehicle for this specific condition prior to receiving this letter, please mail a copy of your repair order, proof-of-payment, and proof-of-ownership to the following address for reimbursement consideration

Toyota Motor Sales, U.S.A., Inc
Toyota Customer Experience, WC 10
19001 South Western Avenue
Torrance, CA 90509

If you are a vehicle lessor, Federal law requires that any vehicle lessor receiving this recall notice must forward a copy of this notice to the lessee within ten days.

We have sent this notice in the interest of your continued satisfaction with our products, and we sincerely regret any inconvenience this condition may have caused you.

Thank you for driving a Toyota.

Sincerely,

TOYOTA MOTOR SALES, U.S.A., INC

Wayne Hutchinson / TMS Toyota Customer Services
Product Quality and Service Support, Quality Compliance
March 8, 2010
Approved By: Bob Waltz

To: All Toyota Dealers
From: Toyota Customer Services

Safety Recall (Special Service Campaign) – 90M
Certain 2000 – 2003 Model Year Toyota Tundra Vehicle in Severe Cold Climate States
Excessive Corrosion of the Rear Cross Member (Spare Tire Carrier)
*******URGENT*******

As announced on November 16, 2009, Toyota filed a Defect Information Report (DIR) with the National Highway Traffic Safety Administration (NHTSA) informing the agency of our intent to conduct a voluntary Safety Recall on certain 2000 - 2003 Model Year Toyota Tundra vehicles **currently registered in or originally sold in** specific Severe Cold Climate States listed below and the District of Columbia:

CT, DE, IL, IN, KY, MA, MD, ME, MI, MN, NH, NJ, NY, OH, PA, RI, VA, VT, WI & WV

Background

- On certain 2000 through 2003 model year Tundra vehicles operated in cold climate areas with high road salt use (*Severe Cold Climate States*) excessive corrosion may be exhibited on the rear cross-member of the frame. In the worst case, the spare tire stowed under the truck bed may become separated from the rear cross-member. Spare tire separation will create a road hazard for following vehicles and could cause a crash without prior warning. Eventually, excessive corrosion of the rear cross-member may also affect the functionality of the rear brake line at the proportioning valve. If this occurs, it can lead to the loss of the rear brake circuits, which will increase vehicle stopping distances and could cause a crash without prior warning.
- In addition, excessive corrosion may also be exhibited on the fuel tank mounting system, which includes two other cross-members and fuel tank straps. In the worst case, the fuel tank may drop to the ground and be dragged or separate from the vehicle. This may create a road hazard which could cause a crash without prior warning or possibly a fire.
- Exposure to cold climate and high road salt usage conditions are primary contributors. This is unrelated to, and separate from, normal surface rust which is commonly found on metallic surfaces after some years of usage and/or exposure to the environment.

Safety Recall Remedy

Dealers are requested to inspect the specified components and adjacent areas of the vehicle (See TIS for additional information). Based upon the inspection, Toyota will do one or more of the following:

- If there is no significant corrosion of the cross-member assemblies, customers will be notified of that fact and requested to subsequently bring the vehicle back to the dealership so that a corrosion-resistant compound can be applied to those assemblies. Owners will be notified when the corrosion-resistant compound is available.
- If significant corrosion of the rear cross member is detected such that it can no longer safely support the spare tire, and replacement components are available, the cross-member assembly will be replaced.
- If the fuel tank straps exhibit deterioration, they will be replaced.

In those relatively rare cases where the rear cross-member is significantly corroded, but cannot be replaced due to excessive frame corrosion at the mounting location (e.g., if the side rails are too damaged), and/or if significant corrosion of either of the fuel tank cross members is detected, Toyota will provide an appropriate remedy on a case-by-case basis.

Involved Vehicles

- There are approximately 110,000 Toyota Tundra (model year 2000 – 2003) vehicles ***registered in or originally sold in*** the states covered by this Safety Recall.

Customer and Media Contacts

- A Q&A has been attached for your use in the event you receive a customer contact. If a customer has further questions, please direct the inquiry to the Toyota Customer Experience Center at 1-800-331-4331.
- If you are a dealership associate and have any questions, please contact your District Service/Parts Manager.
- ***In the event you are contacted by the News media***, it is imperative that all media contacts (local and national) receive a consistent message. Please direct all media contacts to Brian Lyons (310) 468-2552 or John Hanson (310) 468-4718, in Toyota Corporate Communications. (Please do not provide these numbers to customers or call if you are a dealer associate.)

Updated 03/16/2010: Page 6 - fist bullet point updated.

Toyota Motor Sales, U.S.A., Inc.
19001 South Western Avenue
Torrance, CA 90501
(310) 468-4000

Previous versions of this document should be discarded.

To: All Toyota Dealer Principals, Service Managers, Parts Managers

Subject: Safety Recall (Special Service Campaign) – 90M
Certain 2000 – 2003 Model Year Toyota Tundra Vehicle in Severe Cold Climate States
Excessive Corrosion of the Rear Cross Member (Spare Tire Carrier)

As announced on November 16, 2009, Toyota filed a Defect Information Report (DIR) with the National Highway Traffic Safety Administration (NHTSA) informing the agency of our intent to conduct a voluntary Safety Recall on certain 2000 - 2003 Model Year Toyota Tundra vehicles currently registered in or originally sold in specific Severe Cold Climate States listed below and the District of Columbia:

CT, DE, IL, IN, KY, MA, MD, ME, MI, MN, NH, NJ, NY, OH, PA, RI, VA, VT, WI & WV

A separate Special Service Campaign (SSC) 9SM will be launched covering all other 2000-2003 model year Tundra vehicles that were originally sold in and currently registered in the remaining 30 states. Dealerships **will receive a separate communication with respect to that SSC in the near future.**

Background

- On certain 2000 through 2003 model year Tundra vehicles operated in cold climate areas with high road salt use (*Severe Cold Climate States*) excessive corrosion may be exhibited on the rear cross-member of the frame. In the worst case, the spare tire stowed under the truck bed may become separated from the rear cross-member. Spare tire separation will create a road hazard for following vehicles and could cause a crash without prior warning. Eventually, excessive corrosion of the rear cross-member may also affect the functionality of the rear brake line at the proportioning valve. If this occurs, it can lead to the loss of the rear brake circuits, which will increase vehicle stopping distances and could cause a crash without prior warning.
- In addition, excessive corrosion may also be exhibited on the fuel tank mounting system, which includes two other cross-members and fuel tank straps. In the worst case, the fuel tank may drop to the ground and be dragged or separate from the vehicle. This may create a road hazard which could cause a crash without prior warning or possibly a fire.
- Exposure to cold climate and high road salt usage conditions are primary contributors. This is unrelated to, and separate from, normal surface rust which is commonly found on metallic surfaces after some years of usage and/or exposure to the environment.

1. Owner Notification Letter Mailing Date

The owner notification will commence in mid-March, 2010, approximately one week after the dealer notification. The owner letters will be mailed out over approximately one month.

- Safety Recall Notices will be mailed to owners of Tundra vehicles **currently registered in** the 20 Severe Cold Climate States covered by the Safety Recall. A sample of this owner letter is included in this package.
- Owners whose vehicles were **originally sold in** one of those states but are now registered in another state will receive the Safety Recall Notice as well.

2. **Number and Identification of Involved Vehicles**

There are approximately 110,000 Toyota Tundra (model year 2000 – 2003) vehicles registered in or originally sold in the states covered by this Safety Recall.

MODEL	WMI	Year	VIN Range		
			VDS	Range	
Tundra	5TB	2000	BN441	S001001 - S125840	
			BN481	S001001 - S001001	
			BT441	S001001 - S125901	
			BT481	S001001 - S125894	
			JN321	S001001 - S125878	
			KN421	S001001 - S123980	
			KN441	S001001 - S051314	
			KT441	S001001 - S125833	
			RN341	S001001 - S125859	
			RN381	S001001 - S001003	
			RT341	S001001 - S125904	
			RT381	S001001 - S125897	
		2001	BN441	S125937 - S220312	
			BT441	S125905 - S220327	
			BT481	S064335 - S220350	
			JN321	S126112 - S220343	
			KN441	S064852 - S064852	
			KT421	S090565 - S217964	
			KT441	S125921 - S220297	
			RN341	S125909 - S220341	
			RT341	S125907 - S220347	
			RT381	S064333 - S220345	
			2002	BN441	S220394 - S332707
				BT441	S219294 - S332720
		BT481		S219295 - S332685	
		JN321		S220351 - S332714	
		KT421		S220380 - S328382	
		KT441		S220392 - S332706	
		RN341		S220353 - S332719	
		RT341		S220360 - S332721	
		RT381		S220365 - S332666	
		2003		BN441	S332744 - S434010
				BT441	S316368 - S439612
				BT481	S306031 - S439613
			JN321	S332745 - S436914	
			KT421	S332818 - S414089	
KT441	S330788 - S439601				
RN341	S307943 - S436915				
RT341	S306032 - S439732				
RT381	S308386 - S439716				

Please note that all vehicles that were **originally sold in or currently registered in** the covered states are eligible for this inspection and if necessary remedy at **no charge** regardless of the vehicle's age or mileage.

If your dealership is contacted by an owner who has not received a notification, please **verify eligibility by confirming through Dealer Daily/TIS prior to performing repairs**. Dealers should perform the inspection and if necessary repair as outlined in the Technical Instructions found on TIS.

3. **Vehicles in Dealer Stock**

Dealers are requested to perform the inspection and if necessary remedy on any vehicles currently registered in or originally sold in the 20 Severe Cold Climate States prior to delivery. Vehicle Safety Recall completion can be verified through TIS.

4. **Dealer/Owner Lists**

For your reference, the following summary reports are included for dealership Service and Parts Managers located in the **20 Severe Cold Climate States only**:

- **Dealer Reports will no longer contain a PMA VIN list.** However, they will contain the number of involved vehicles registered in each dealership's primary marketing area and initial suggested parts order quantities, where applicable.

Dealerships located in the remaining 30 states will not receive any reports.

5. **Parts Ordering**

Since not all vehicles will require cross-member and/or associated parts replacement, these parts will be placed on Manual Allocation Control (MAC).

While the parts are on MAC, a representative from TMS will review each order and contact the dealership's Parts Manager to verify the necessity of the order. This will assure an adequate and balanced parts inventory.

If there are special circumstances where a dealer is having difficulty receiving parts, dealership associates may contact (310) 468-5516 to research their order for the cross-member parts. The associate should have the following information ready to expedite research of the order status:

1. Dealer Information (Dealer Code, Contact Name, Telephone Number)
2. Order Reference Number
3. Customer Name and Vehicle 17-digit VIN

Please refer to the table below for rear cross member part numbers. Additional part number information can be found in the Technical Instructions (located on TIS). Parts can be ordered from your facing PDC.

- For 2000 – 2002 Model Year

Part Number	Part Description	Quantity
51209-0C010	Rear Frame Cross Member Sub-assembly	1
90080-11288	Bolt	13
90178-A0082	Nut	13

- For 2003 Model Year

Part Number	Part Description	Quantity
51209-0C012	Rear Frame Cross Member Sub-assembly	1
90080-11288	Bolt	13
90178-A0082	Nut	13



***Part replacement is based on inspection results. DO NOT order parts until the vehicle inspection has been completed. Refer to the Technical Instructions posted on TIS for additional part number information.**

In the event parts are not available, please refer to the Technical Instructions for specific criteria and handling. This includes making a rental vehicle available based upon the inspection results.

IMPORTANT PARTS ORDERING REMINDER

Effective March 1, 2009, Safety Recall, Service Campaign (SSC/LSC) and Customer Support Program (CSP) parts do not earn Parts Return Credit Accrual and are not returnable under the Monthly Return Program. It is recommended that you order these parts based on appointments or immediate customer needs using a "Sell One-Buy One" ordering pattern. Please refer to PANT Bulletin 09-12 for additional details.

[Parts Ordering continued...]

This UIO matrix is provided to inform your dealership of the approximate number of vehicles in your state that are covered by this Safety Recall.

State	2000 MY	2001 MY	2002 MY	2003 MY	Total
CT	1017	675	840	804	3,336
DC	60	31	43	44	178
DE	250	130	163	173	716
IL	1,764	1,217	1,604	1,401	5,986
IN	1,461	844	1,207	1,114	4,626
KY	2,184	1,127	1,351	1,185	5,847
MA	2,661	1,864	2,415	2,482	9,422
MD	1,976	1,222	1,592	1,888	6,678
ME	916	606	782	774	3,078
MI	1,203	659	863	799	3,524
MN	1,389	957	1,367	1,135	4,848
NH	996	691	775	893	3,355
NJ	1,470	937	1,129	1,208	4,744
NY	2,202	1,508	1,818	1,958	7,486
OH	2,502	1,233	1,550	1,525	6,810
PA	3,003	1,775	2,090	2,096	8,964
RI	438	272	358	354	1,422
VA	3,667	2,251	2,885	2,987	11,790
VT	543	333	455	474	1,805
WI	1,689	967	1,348	1,216	5,220
WV	763	441	490	534	2,228
TOTAL	32,154	19,740	25,125	25,044	102,063

Additional information, including part number and ordering procedures on a Corrosion Resistant Compound application will be provided as preparations are completed.

6. Technical Instructions

Refer to TIS for Technical Instructions on inspection and if necessary replacement procedures for the Rear Cross-Member, rear brake line at the proportioning valve, spare tire carrier and fuel tank mounting system.

7. Customer Handling Process, if parts are not available for required repairs

- Toyota is working quickly to ensure that sufficient quantities of replacement Rear Cross-Members and ancillary parts are available for this program. We understand there may be unique situations that require case-by-case handling. In these special circumstances, please contact your DSPM. They will work with your dealership to resolve issues where possible before escalating the case.

8. Tools and Equipment

In a separate shipment in early March 2010, dealerships in CT, DE, IL, IN, KY, MA, MD, ME, MI, MN, NH, NJ, NY, OH, PA, RI, VA, VT, WI & WV were sent a Safety Recall 90M Campaign Tool. This shipment included the required Frame Expansion Bar.

The Safety Recall 90M Campaign Tool package is labeled with a fluorescent (green, orange, yellow or pink) label like the sample seen below for easy identification.

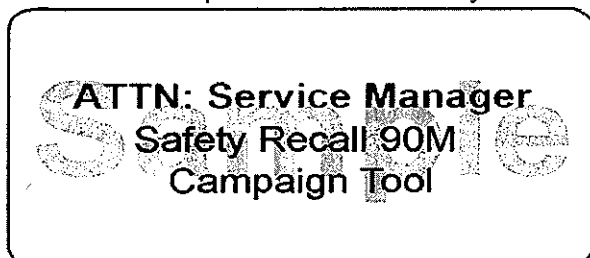

The additional required tools and equipment are listed in the technical instructions found on TIS.

9. **Warranty Processor Instructions**

Please note the following for this campaign:

- **This Safety Recall involves the inspection of the Rear Cross-Member, Brake Tube, LSPV, Spare Tire Carrier and Fuel Tank Strap, and if applicable the replacement of the aforementioned parts.**

OPERATION FLOW CHART

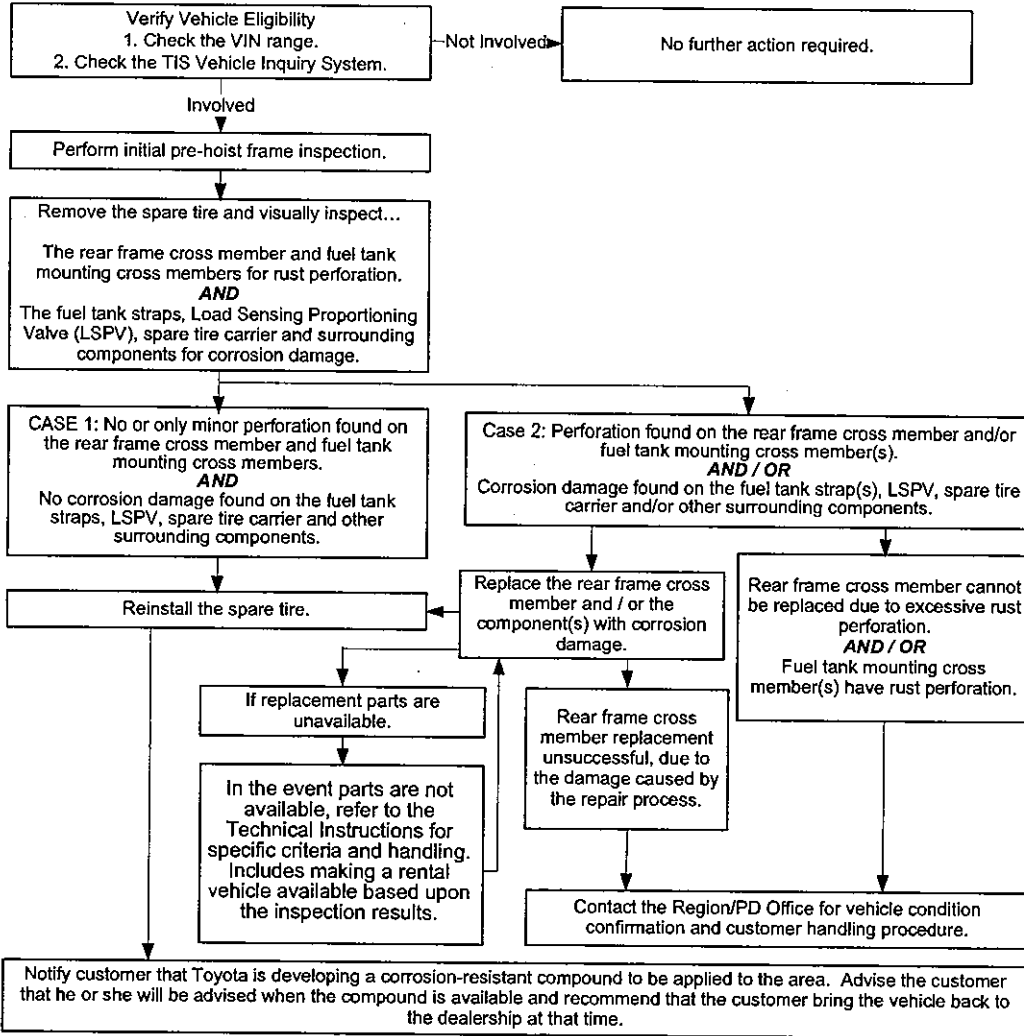

Submit Safety Recall claims following the procedures described in the Toyota Warranty Policy and Procedures Manual.

Part 1: Vehicle Inspection and Judgment Codes (Case 1 from Flowchart)

All inspection operation code (Op. Code) claims must be filed as a separate claim from the repair.

Safety Recall #	Op. Code	Description	Flat Rate Hour
90M	0505CA	Inspect the Rear Cross-Member and surrounding components (Brake Tube, LSPV, Fuel Tank Mounting System, Spare Tire Carrier, etc.) for Rust Perforation [No Rust Perforation and no surrounding component damage found (Case 1 shown in the Flow Chart)] NO PARTS REPLACEMENT REQUIRED	0.5 hr/vehicle
	0505CB	Inspect the Rear Cross-Member and surrounding components (Brake Tube, LSPV, Fuel Tank Mounting System, Spare Tire Carrier, etc.) for Rust Perforation [Rust Perforation and/or surrounding component damage found (Case 2 shown in the Flow Chart)] PARTS REPLACEMENT REQUIRED	0.5 hr/vehicle

NOTE: The above flat rate times includes 0.1 hour for administrative cost per unit for the dealership.

Part 2: Vehicle Repair Codes (Case 2 from Flowchart)

All inspection operation code (Op. Code) claims must be filed as a separate claim from the repair.

Choose one of appropriate operation code from the matrix on the next page according to the valuation and combination of necessary repair work(s) below.

[Warranty Processor Instructions continued...]

The following operation codes are only to be used in the event that the vehicle requires the replacement of the Rear Cross-Member, Fuel Tank Strap(s), Brake Tube, LSPV and Spare Tire Carrier. If these components can not be replaced, due to excessive rust perforation and/or the Fuel tank mounting cross member(s) have rust perforation contact your Region/Private Distributor Representative immediately.

Please indicate the corresponding Repair Work # (see table below) in the Condition Cause Remedy (CCR) section of the claim to signify which repairs were done based on the op. code as a cross-reference.

For example:

- If op. code 0506C7 (corresponding to Repair Work #'s 1, 3 and 4) is used. The CCR should state: "Repair Work #'s 1, 3, & 4."

Additional information, including operation codes for the Corrosion Resistant Compound application will be provided as preparations are completed.

Part 2: Vehicle Repair Codes (Continued – Case 2 from Flowchart)

Repair Work #	Description of Repair Work
1	Replace the rear cross member. This includes reinstalling the original or new spare tire carrier to the new rear cross-member
2	Replace the brake tube including air bleeding
3	Replace the LSPV including air bleeding
4	Replace the fuel tank strap(s)
5	Replace the spare tire carrier

Safety Recall/SSC #	Op. Code	Description (Affected Repair Work # above)					Flat Rate Hour
		1	2	3	4	5	
90M	0506C1	✓	-	-	-	-	5.0 hr/vehicle
	0506C2	✓	✓	-	-	-	5.5 hr/vehicle
	0506C3	✓	✓	✓	-	-	6.9 hr/vehicle
	0506C4	✓	✓	✓	✓	-	7.2 hr/vehicle
	0506C5	✓	✓	-	✓	-	5.8 hr/vehicle
	0506C6	✓	-	✓	-	-	6.6 hr/vehicle
	0506C7	✓	-	✓	✓	-	6.9 hr/vehicle
	0506C8	✓	-	-	✓	-	5.3 hr/vehicle
	0506C9	-	✓	-	-	-	0.5 hr/vehicle
	0506CA	-	✓	✓	-	-	1.9 hr/vehicle
	0506CB	-	✓	✓	✓	-	2.2 hr/vehicle
	0506CC	-	✓	✓	✓	✓	2.7 hr/vehicle
	0506CD	-	✓	✓	-	✓	2.4 hr/vehicle
	0506CE	-	✓	-	✓	-	0.8 hr/vehicle
	0506CF	-	✓	-	✓	✓	1.3 hr/vehicle
	0506CG	-	✓	-	-	✓	1.0 hr/vehicle
	0506CH	-	-	-	✓	-	1.6 hr/vehicle
	0506CJ	-	-	✓	✓	-	1.9 hr/vehicle
	0506CK	-	-	✓	✓	✓	2.4 hr/vehicle
	0506CL	-	-	✓	-	✓	2.1 hr/vehicle
0506CM	-	-	-	✓	-	0.3 hr/vehicle	
0506CN	-	-	-	✓	✓	0.8 hr/vehicle	
0506CP	-	-	-	-	✓	0.5 hr/vehicle	
0506CQ	Rear cross-member replacement unsuccessful, due to the damage caused by the repair process					3.0 hr/vehicle	

Note: For Operation Code 0506C1 through 0506C8 and 0506CQ which contain the cross-member replacement, \$8.00 per vehicle for the cost of the chisel cutter should be included on the SSC claim. Use "ZZ" sublet type. State "Chisel Cutter" in the sublet description. Sublet cost maximum is \$8.00.

**SSC 90M – Certain 2000 through 2003 Tundra Vehicles
Severe Corrosion of the Rear Cross-Member
SAFETY RECALL NOTICE**

Dear Toyota Customer:

This notice is being sent to you in accordance with the requirements of the National Traffic and Motor Vehicle Safety Act. Toyota has decided that a defect, which relates to motor vehicle safety, exists in certain 2000 through 2003 model year Tundra vehicles.

What is the condition?

On certain 2000 through 2003 model year Tundra vehicles originally sold in and/or registered and operated in cold climate areas with high road salt use (*Severe Cold Climate States*), excessive corrosion may be exhibited on the rear cross-member of the frame. In the worst case, the spare tire stowed under the truck bed may become separated from the rear cross-member. Spare tire separation will create a road hazard for following vehicles and could cause a crash without prior warning. Eventually, excessive corrosion of the rear cross-member may also affect the functionality of the rear brake line at the proportioning valve. If this occurs, it can lead to the loss of the rear brake circuits, which will increase vehicle stopping distances and could cause a crash without prior warning.

In addition, excessive corrosion may also be exhibited on the fuel tank mounting system, which includes two other cross-members and fuel tank straps. In the worst case, the fuel tank may drop to the ground and be dragged or separate from the vehicle. This may create a road hazard which could cause a crash without prior warning or possibly a fire.

What will Toyota do?

Any Toyota Dealer will inspect the specified components and adjacent areas of your vehicle. Please see your dealership for details. Based upon the inspection, Toyota will do one or more of the following **at no charge** to you:

- If there is no significant corrosion of the cross-member assemblies, you will be notified of that fact and requested to subsequently bring your vehicle back to the dealership so that a corrosion-resistant compound can be applied to those assemblies. Toyota will notify you when the corrosion-resistant compound is available.
- If significant corrosion of the rear cross member is detected such that it can no longer safely support the spare tire, and replacement components are available, the cross-member assembly will be replaced.
- If the fuel tank straps exhibit deterioration, they will be replaced.

In those relatively rare cases where the rear cross-member is significantly corroded, but cannot be replaced due to excessive frame corrosion at the mounting location (e.g., if the side rails are too damaged), and/or if significant corrosion of either of the fuel tank cross members is detected, Toyota will provide an appropriate remedy on a case-by-case basis.

Below is the "rental only" op. code which should be used for submitting rental claims. **Rental expense will be submitted separately from repair/replacement for this Safety Recall only and document attachments** may be requested by the Warranty Department,

SSC #	Op. Code	Description	Flat Rate Hour
90M	9502LL	Vehicle Rental 1-30 days	Maximum \$35.00 per day
	9502LM	Vehicle Rental 31-60 days (Usage of this operation code requires DSPM Authorization)	Maximum \$35.00 per day

Note: For Operation Code 9502LL, use "RT" sublet type. Special accommodations based upon customer needs, not outlined above require DSPM authorization.

Please review this entire package with your Service and Parts staff to familiarize them with the proper step-by-step procedures required to implement this Special Service Campaign.

Thank you for your cooperation.
TOYOTA MOTOR SALES, U.S.A., INC.

TECHNICAL INSTRUCTIONS

FOR

SAFETY RECALL 90M

FOR VEHICLES
ORIGINALLY SOLD IN OR CURRENTLY REGISTERED IN

CT, DE, IL, IN, KY, MA, MD, ME, MI, MN, NH,
NJ, NY, OH, PA, RI, VA, VT, WI & WV

REAR FRAME CROSS MEMBER REPLACEMENT

ON

2000 THROUGH 2003 MODEL YEAR TUNDRA

What should you do?

This is an important Safety Recall

Please contact your authorized Toyota dealer to make an appointment to have the inspection performed as soon as possible. The inspection will take approximately 30 minutes. If a rear cross member assembly is replaced at the time of this inspection, the repair will take approximately 8 hours. Moreover, depending upon the dealer's work schedule, it may be necessary to make your vehicle available for a longer period of time.

This Safety Recall involves customers whose vehicles are registered or originally purchased in the following 20 Severe Cold Climate States and the District of Columbia.

CT, DE, IL, IN, KY, MA, MD, ME, MI, MN, NH, NJ, NY, OH, PA, RI, VA, VT, WI & WV

We request that you present this notice to the dealer at the time of your service appointment.

If you would like to update your vehicle ownership or contact information, please go to www.toyota.com/ownersupdate. You will need your full 17-digit Vehicle Identification Number (VIN) to input the new information.

If you have moved to another state, but would like to have your vehicle inspected, please contact your local Toyota dealer and make an appointment. Toyota will perform the same inspection and, if necessary repair, at **no charge**. Please see your dealer for details.

What if you have other questions?

Your local Toyota dealer will be more than happy to answer any of your questions and set up an appointment to perform this important Safety Recall. If you require further assistance, you may contact the Toyota Customer Experience Center at 1-888-270-9371 Monday through Friday, 5:00 am to 6:00 pm, Saturday 7:00 am through 4:00 pm Pacific Time.

If you believe that the dealer or Toyota has failed, or is unable to remedy the defect within a reasonable time, you may submit a complaint to the Administrator, National Highway Traffic Safety Administration, 1200 New Jersey Avenue S.E., Washington, DC 20590 or call the toll free Vehicle Safety Hot Line at 1-888-327-4236 (TTY: 1-800-424-9453), or go to <http://www.safercar.gov>.

What if you have previously paid for repairs to your vehicle for this specific condition?

If you have previously paid for repair to your vehicle for this specific condition prior to receiving this letter, please mail a copy of your repair order, proof-of-payment, and proof-of-ownership to the following address for reimbursement consideration

Toyota Motor Sales, U.S.A., Inc
Toyota Customer Experience, WC 10
19001 South Western Avenue
Torrance, CA 90509

If you are a vehicle lessor, Federal law requires that any vehicle lessor receiving this recall notice must forward a copy of this notice to the lessee within ten days.

We have sent this notice in the interest of your continued satisfaction with our products, and we sincerely regret any inconvenience this condition may have caused you.

Thank you for driving a Toyota.

Sincerely,

TOYOTA MOTOR SALES, U.S.A., INC

I. OPERATION FLOW CHART

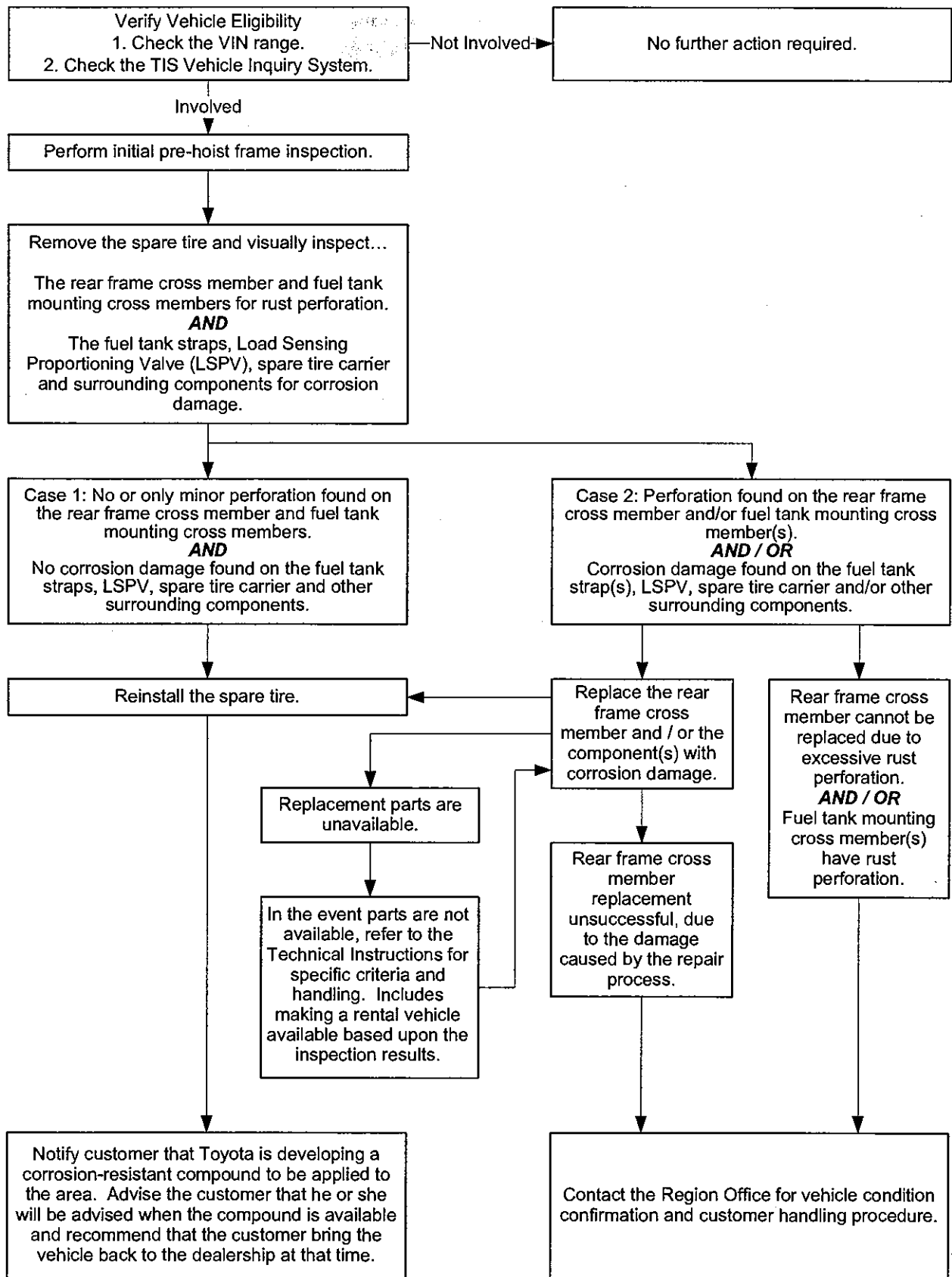

II. IDENTIFICATION OF AFFECTED VEHICLES

A. AFFECTED VIN RANGE

Model	WMI	Year	VIN Range	
			VDS	Range
Tundra	5TB	2000	BN441	S001001 – S125840
			BN481	S001001 – S001001
			BT441	S001001 – S125901
			BT481	S001001 – S125894
			JN321	S001001 – S125878
			KN421	S001001 – S123980
			KN441	S001001 – S051314
			KT441	S001001 – S125833
			RN341	S001001 – S125859
			RN381	S001001 – S001003
			RT341	S001001 – S125904
			RT381	S001001 – S125897
		2001	BN441	S125937 – S220312
			BT441	S125905 – S220327
			BT481	S064334 – S220350
			JN321	S126112 – S220343
			KN441	S064852 – S064852
			KT421	S090565 – S217964
			KT441	S125921 – S220297
			RN341	S125909 – S220341
			RT341	S125907 – S220347
			RT381	S064333 – S220345
		2002	BN441	S220394 – S332707
			BT441	S219294 – S332720
			BT481	S219295 – S332685
			JN321	S220351 – S332714
			KT421	S220380 – S328382
			KT441	S220392 – S332706
			RN341	S220353 – S332719
			RT341	S220360 – S332721
		RT381	S220365 – S332666	
		2003	BN441	S332744 – S434010
			BT441	S316368 – S439612
			BT481	S306031 – S439613
			JN321	S332745 – S436914
			KT421	S332818 – S414089
KT441	S330788 – S439601			
RN341	S307943 – S436915			
RT341	S306032 – S439732			
RT381	S308386 – S439716			

NOTE:

- Check the TIS Vehicle Inquiry System to confirm the VIN is involved in this Safety Recall, and that the campaign has not already been completed prior to dealer shipment or by another dealer.
- TMS warranty will not reimburse dealers for repairs conducted on vehicles that are not affected or were completed by another dealer.

III. BACKGROUND

- On certain 2000 through 2003 model year Tundra vehicles operated in cold climate areas with high road salt use (*Severe Cold Climate States*) excessive corrosion may be exhibited on the rear cross-member of the frame. In the worst case, the spare tire stowed under the truck bed may become separated from the rear cross-member. Spare tire separation will create a road hazard for following vehicles and could cause a crash without prior warning. Eventually, excessive corrosion of the rear cross-member may also affect the functionality of the rear brake line at the proportioning valve. If this occurs, it can lead to the loss of the rear brake circuits, which will increase vehicle stopping distances and could cause a crash without prior warning.
- In addition, excessive corrosion may also be exhibited on the fuel tank mounting system, which includes two other cross-members and fuel tank straps. In the worst case, the fuel tank may drop to the ground and be dragged or separate from the vehicle. This may create a road hazard which could cause a crash without prior warning or possibly a fire.
- Exposure to cold climate and high road salt usage conditions are primary contributors. This is unrelated to, and separate from, normal surface rust which is commonly found on metallic surfaces after some years of usage and/or exposure to the environment.

IV. VEHICLE INSPECTION WORK PROCEDURE

A. INITIAL PRE-HOIST FRAME INSPECTION

1. INSPECT THE FRAME FOR RUST PERFORATION

- If NG (rust perforation found), use a drive on vehicle lift to inspect the frame cross members. **Do not lift vehicle by the frame.**
- If OK (no rust perforation), you may use a frame contacting vehicle lift to inspect the frame cross members.
- Proceed to frame cross member inspection below.

B. INSPECT THE REAR FRAME CROSS MEMBER AND FUEL TANK MOUNTING CROSS MEMBERS

1. REMOVE THE SPARE TIRE AND INSPECT THE REAR FRAME CROSS MEMBER FOR RUST PERFORATION

GUSSET AREA ONLY

NG Condition, Replacement Required:
Any perforation in gusset area where the LSPV is installed.



ALL OTHER AREAS (EXCEPT THE GUSSET)

NG Condition, Replacement Required:

Case 1: Perforation exceeds 30mm in diameter.

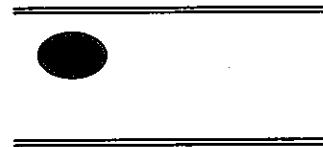

Case 2: 2 holes within 10 mm.

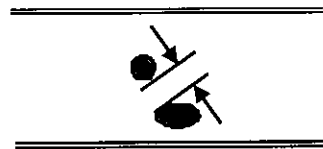

Case 3: More than 3 perforated spots.

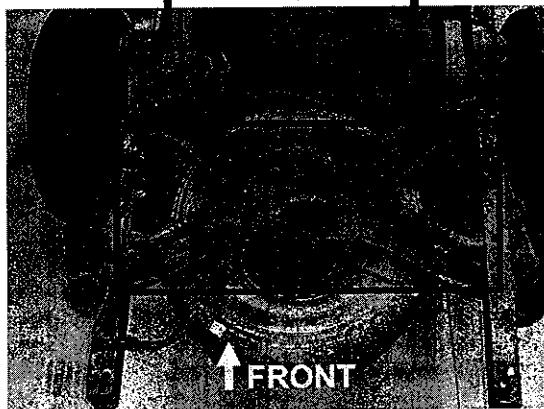
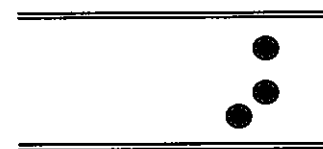

For part number information, please reference Section V "PARTS INFORMATION"

2. INSPECT THE FUEL TANK MOUNTING CROSS MEMBERS FOR RUST PERFORATION

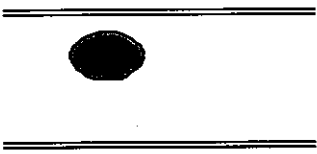
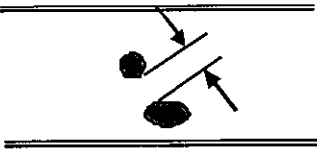
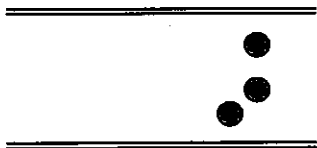
Judgement Criteria	Result	Action
<ul style="list-style-type: none"> A perforation (hole) of over 30 mm in locations A, B, C or D, see below 	NG	Replace the frame
<ul style="list-style-type: none"> 2 perforations (holes) within 10 mm of each other in locations A, B, C or D, see below 		
<ul style="list-style-type: none"> More than 3 perforations (holes) in locations A, B, C or D, see below 		
None of the above conditions	OK	No action required

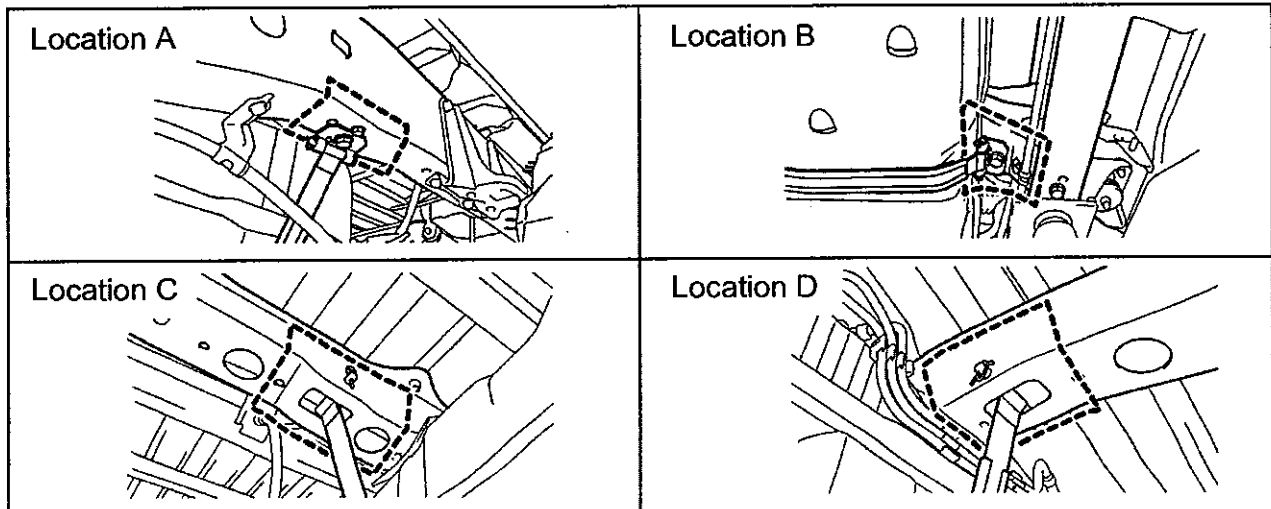
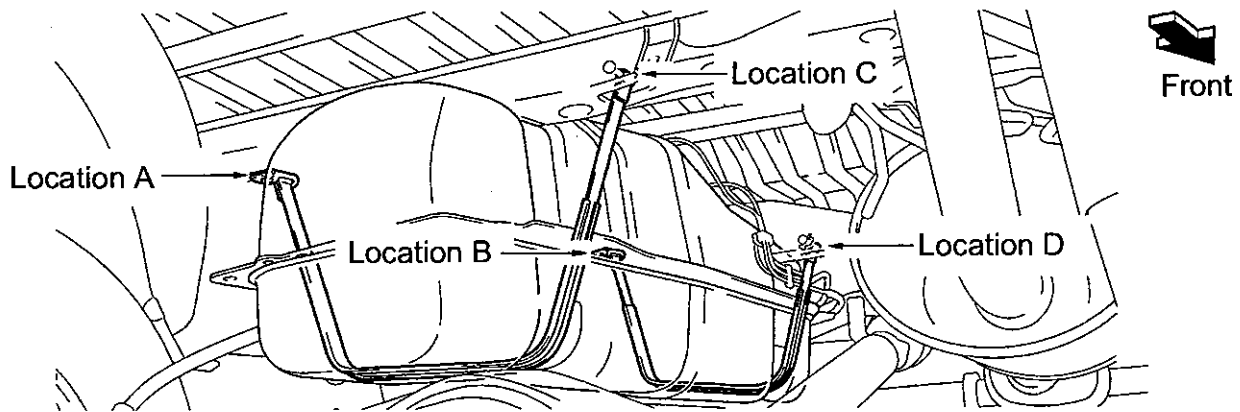



- If parts are ***NOT*** available for the components requiring replacement (i.e. brake components, fuel tank straps, fuel lines, lspv, spare tire carrier, etc.) inform the customer and provide them with a rental vehicle. Contact the customer when parts become available.
- Follow the Toyota Transportation Assistance Program (TTAP) guidelines for rentals.

C. INSPECT THE FUEL TANK STRAPS, LSPV, SPARE TIRE CARRIER AND SURROUNDING COMPONENTS

1. INSPECT THE FUEL TANK STRAPS FOR CORROSION DAMAGE

- a) Using a piece of cloth, clean the outside surface of the front and rear fuel tank straps to remove any dirt and debris.

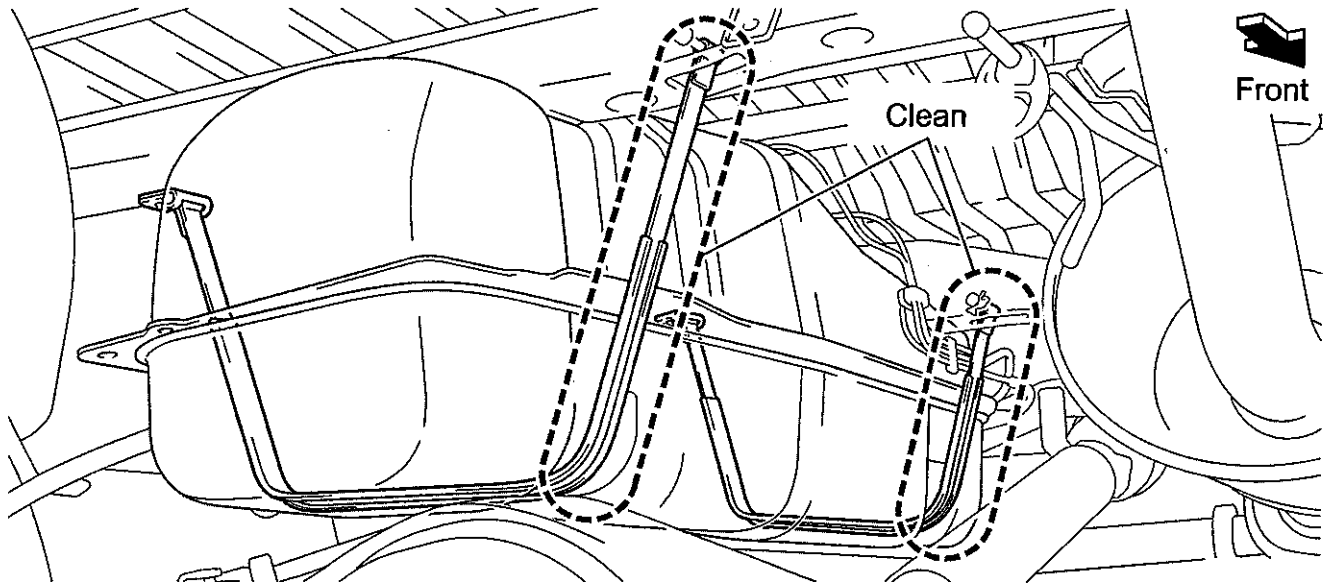

b) Inspect the outside surface of the fuel tank straps, does the rust span the width (front to rear) of either fuel tank strap as shown.

Inspection Area:

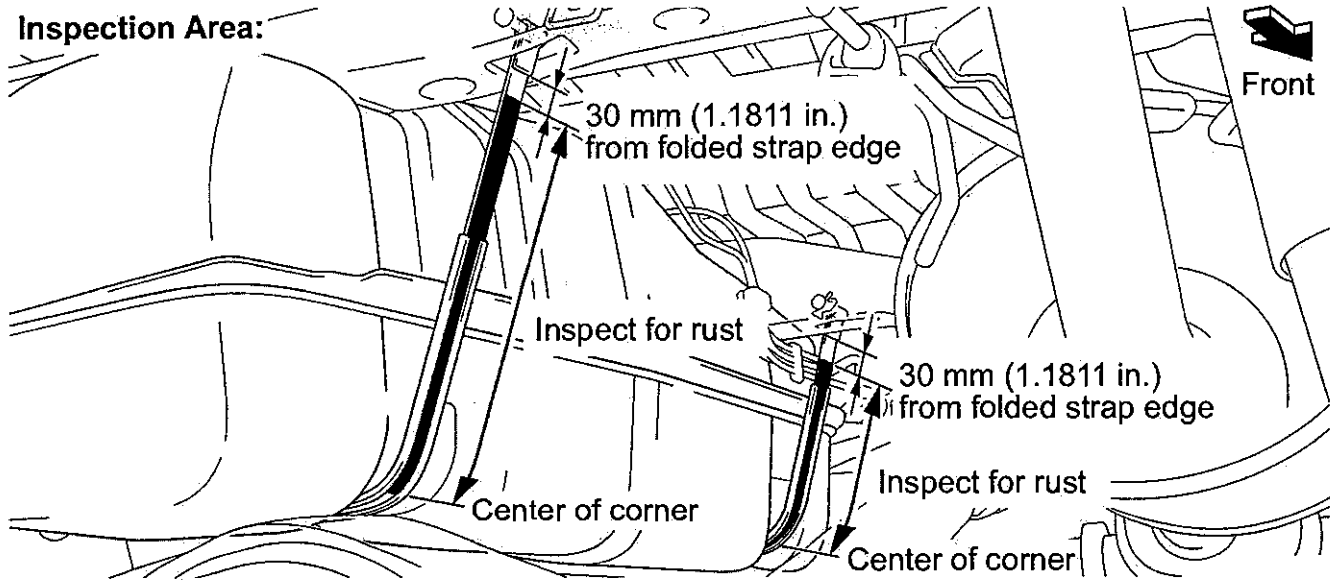

Inspection Standard:

Rusting occurs continuously along the entire width of the strap.

Rusting does not occur continuously along the entire width of the strap.

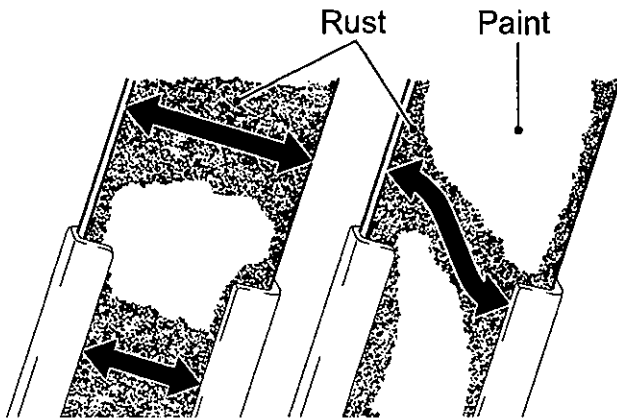

NG

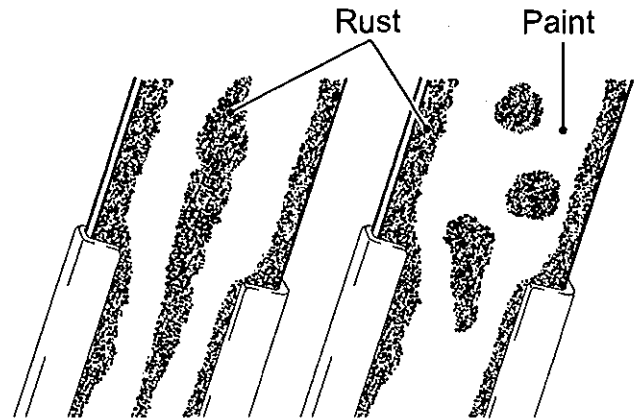

OK

Judgement Criteria	Action
NG	Replace the fuel tank strap(s) For part number information, please reference Section V "PARTS INFORMATION"
OK	Replacement not required

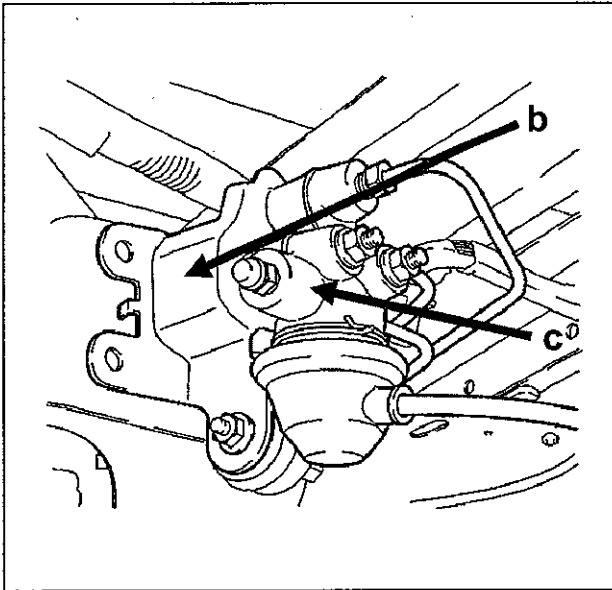

2. INSPECT THE LSPV

- a) If there are signs of excessive rust and brake fluid leakage on the LSPV, replace the damaged parts.
- b) With one hand using minimal force, attempt to wiggle the **valve bracket (b)**.
 - If the valve bracket is loose, replace the damaged part.
- c) With one hand using minimal force, attempt to wiggle the **valve body (c)**.
 - If the valve body and/or associated components are loose or show any signs of leakage, replace the damaged parts.
 - For part number information, please reference Section V "PARTS INFORMATION"

3. INSPECT THE SPARE TIRE CARRIER FOR DETERIORATION

a) Inspect the spare tire carrier lift plate as shown.

Judgement Criteria	Result	Action
Deterioration Found	NG	Replace the spare tire carrier For part number information, please reference Section V "PARTS INFORMATION"
No Deterioration	OK	Replacement not required

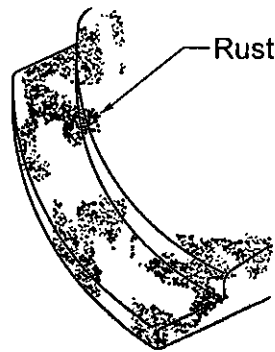
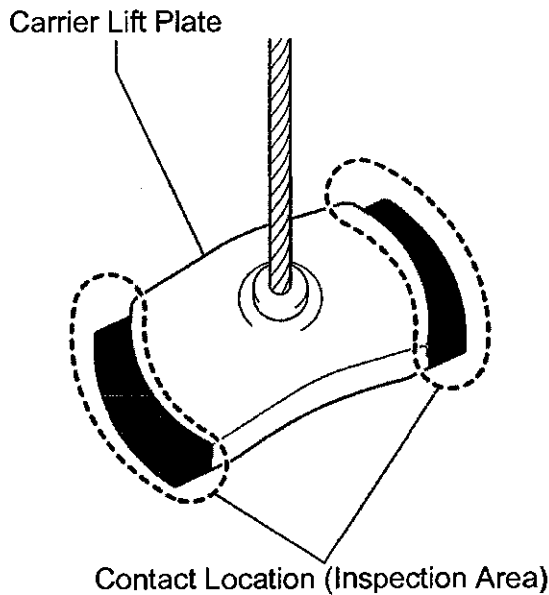

OK

Rust but no deterioration or holes present

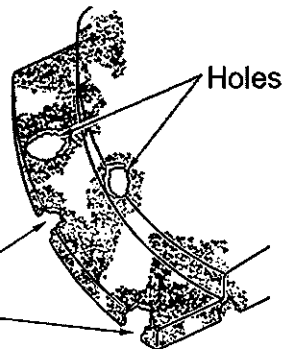

NG

Deterioration or holes present

4. INSPECT SURROUNDING COMPONENTS AND ADJACENT AREAS

a) Inspect the...

- Brake lines
- Fuel lines
- Exhaust pipe brackets
- Steering components and power steering lines
- Suspension mounts

NOTE:

- If there is perforation and/or breakage of the specified components or adjacent areas due to corrosion replace the damaged part(s).
- If there is fluid leakage of the specified components replace the damaged part(s).

V. PARTS INFORMATION

• **Rear Frame Cross Member**

MY	Description	Part Number	Part Name	Quantity
2000 – 2002	-	51209-0C010	Rear Frame Cross Member Sub-assembly	1
2003	-	51209-0C012	Rear Frame Cross Member Sub-assembly	1
All	-	90080-11288	Bolt	13
All	-	90178-A0082	Nut	13

• **Fuel Tanks Strap**

MY	Description	Part Number	Part Name	Quantity
2000	2WD	77601-34030	Fuel Tank Strap Sub-assembly No.1	1
		77603-34070	Fuel Tank Strap Sub-assembly No.2	1
	4WD	77601-34040	Fuel Tank Strap Sub-assembly No.1	1
		77603-34060	Fuel Tank Strap Sub-assembly No.2	1
2001 – 2003	2WD <i>Except UCK30 Off Road Package</i>	77601-34030	Fuel Tank Strap Sub-assembly No.1	1
		77603-34070	Fuel Tank Strap Sub-assembly No.2	1
	4WD <i>Includes UCK30 Off Road Package</i>	77601-34040	Fuel Tank Strap Sub-assembly No.1	1
		77603-34060	Fuel Tank Strap Sub-assembly No.2	1

• **Load Sensing Proportioning Valve (LSPV)**

MY	Description	Part Number	Part Name	Quantity
2000 – 2002	WO/ABS	47910-34060	LSPV Assembly	1
2000 – 2003	WI/ABS	47910-34070	LSPV Assembly	1

• **Spare Tire (Wheel) Carrier**

MY	Description	Part Number	Part Name	Quantity
All	-	51900-0C010	Spare Wheel Carrier Assembly	1

NOTE:

- Depending on the vehicle condition, additional parts may be required.
- Correct parts number should be confirmed with the parts catalog.

VI. REAR FRAME CROSS MEMBER REPLACEMENT WORK PROCEDURE

A. TOOLS & EQUIPMENT

- Standard hand tools
- Torque wrench
- Torx ® T55H Tamper Resistant Socket
- Air hammer with...
 - Flat chisel bit
 - Tapered punch bit
- Steel tape measure
- Frame expansion bar*
- Protective eyewear
- Protective work gloves
- Ear plugs
- Dust mask

***NOTE:**

One Frame Expansion Bar will be provided to each dealer in CT, DE, IL, IN, KY, MA, MD, ME, MI, MN, NH, NJ, NY, OH, PA, RI, VA, VT, WI & WV.

B. MATERIALS

- Black paint (chassis black or black anti-corrosive paint)
- Sandpaper 80 grit

C. COMPONENTS

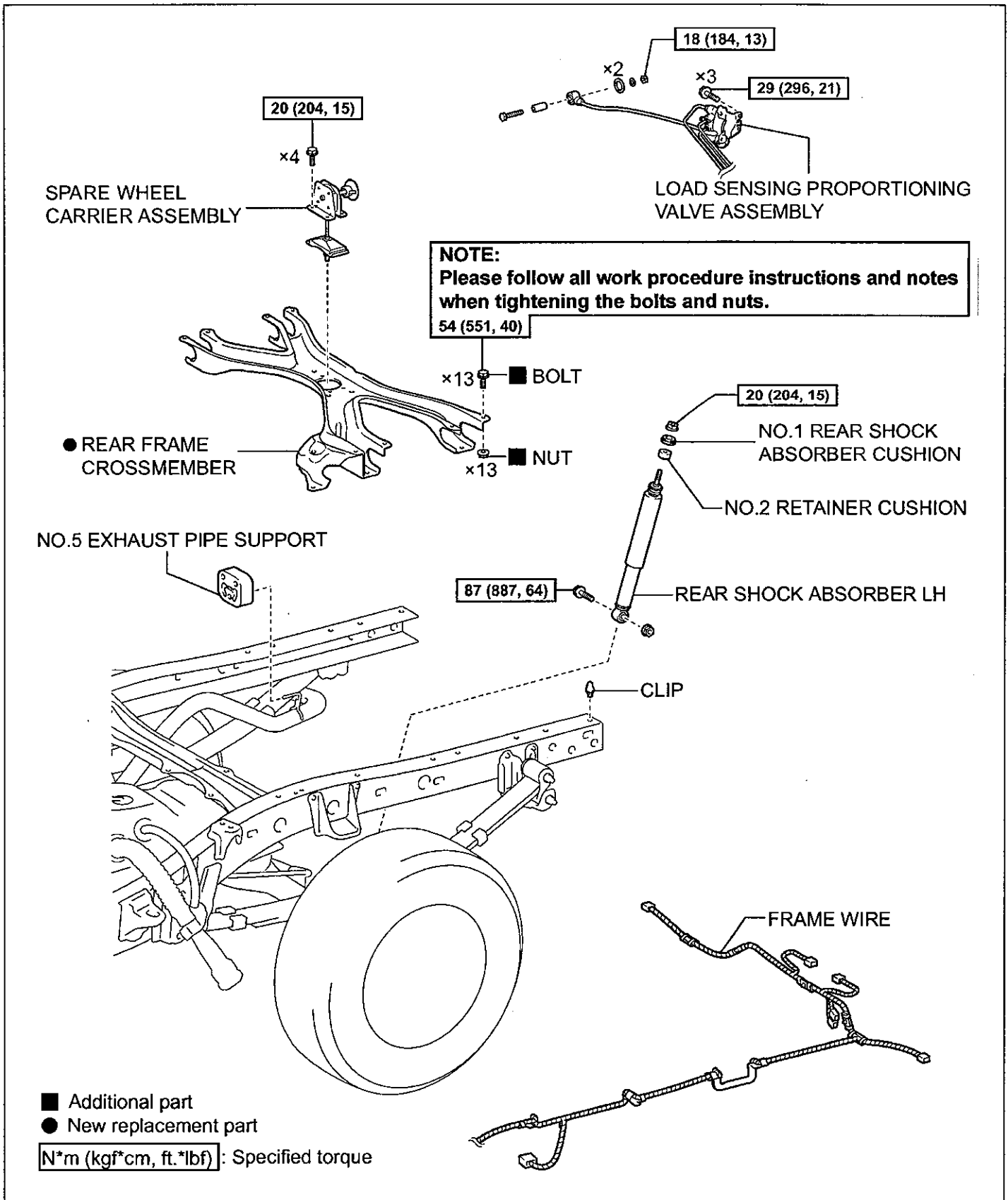

D. LOCATION AND TORQUE SPECIFICATIONS FOR SURROUNDING COMPONENTS IF REPLACED

Location reference diagram and torque values for replacing brake harness and LSPV.

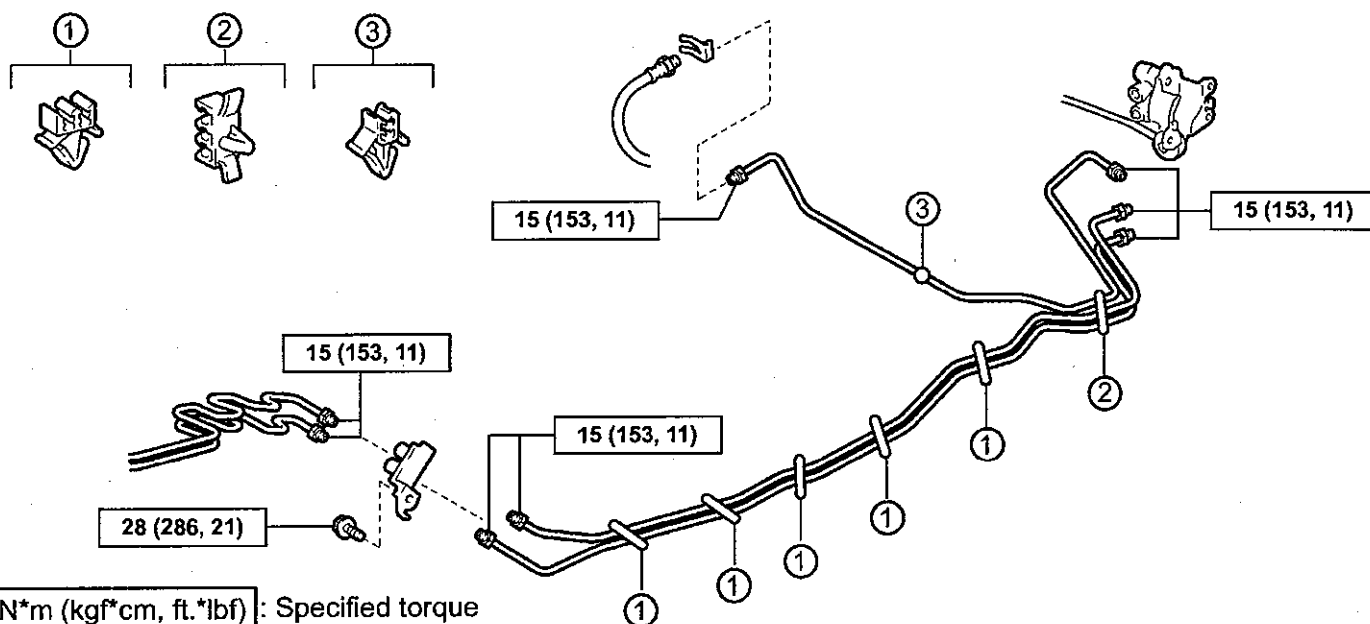
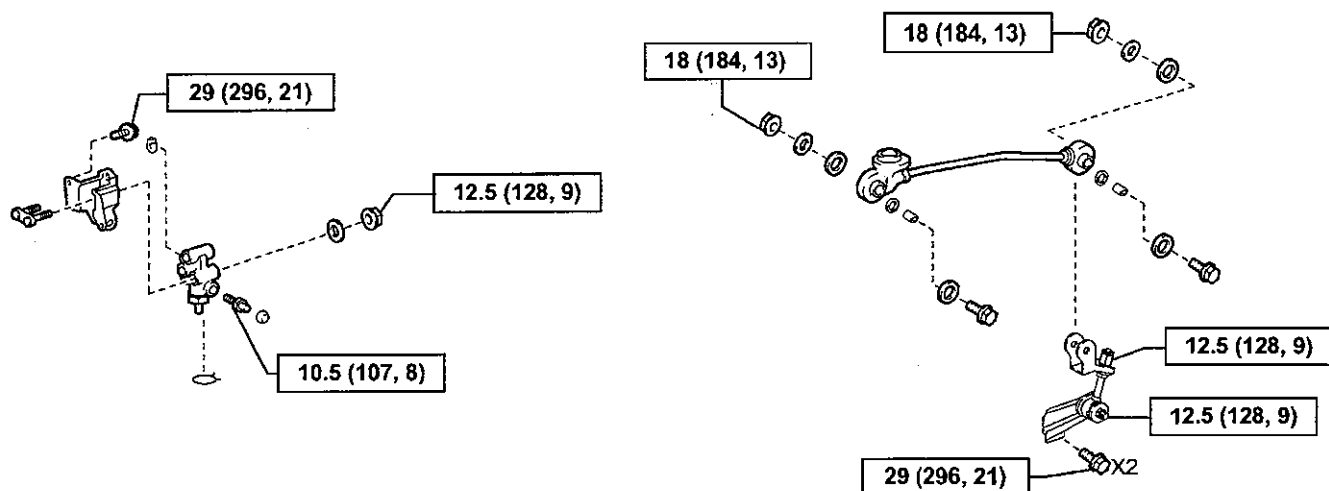

E. REAR FRAME CROSS MEMBER REMOVAL

1. REMOVE THE LICENSE PLATE LIGHTS
2. REMOVE THE CENTER REAR BUMPER PAD
3. REMOVE THE REAR BUMPER ASSEMBLY
4. REMOVE THE TRAILER HITCH (IF EQUIPPED)

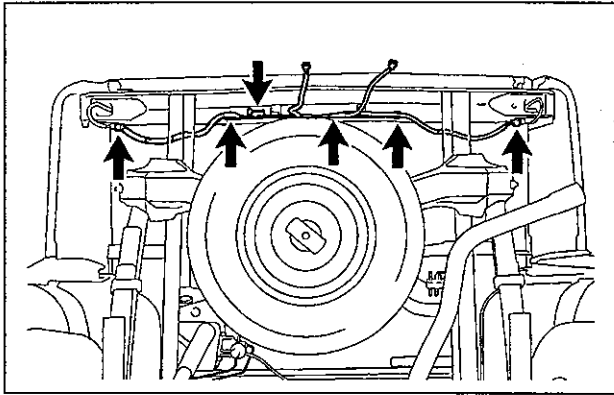

5. DISCONNECT THE FRAME WIRE HARNESS

- a) Disconnect the connectors.
- b) Disconnect the clips and the frame wire harness from the bed assembly.

NOTE:

- The number of connectors may differ depending on the vehicle specification.
- Be careful not to damage the wire harness clips when removing them.

6. REMOVE THE REAR MUDGUARDS (IF EQUIPPED)

7. REMOVE THE FUEL TANK FILLER PIPE SHIELD

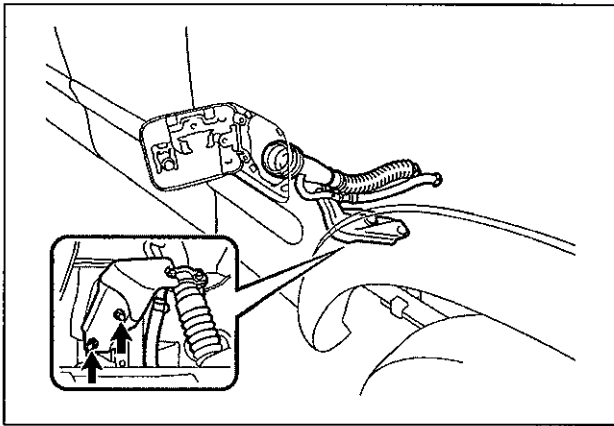

8. DISCONNECT THE FUEL INLET PIPE

- a) Remove the 2 nuts and disconnect the fuel inlet pipe.

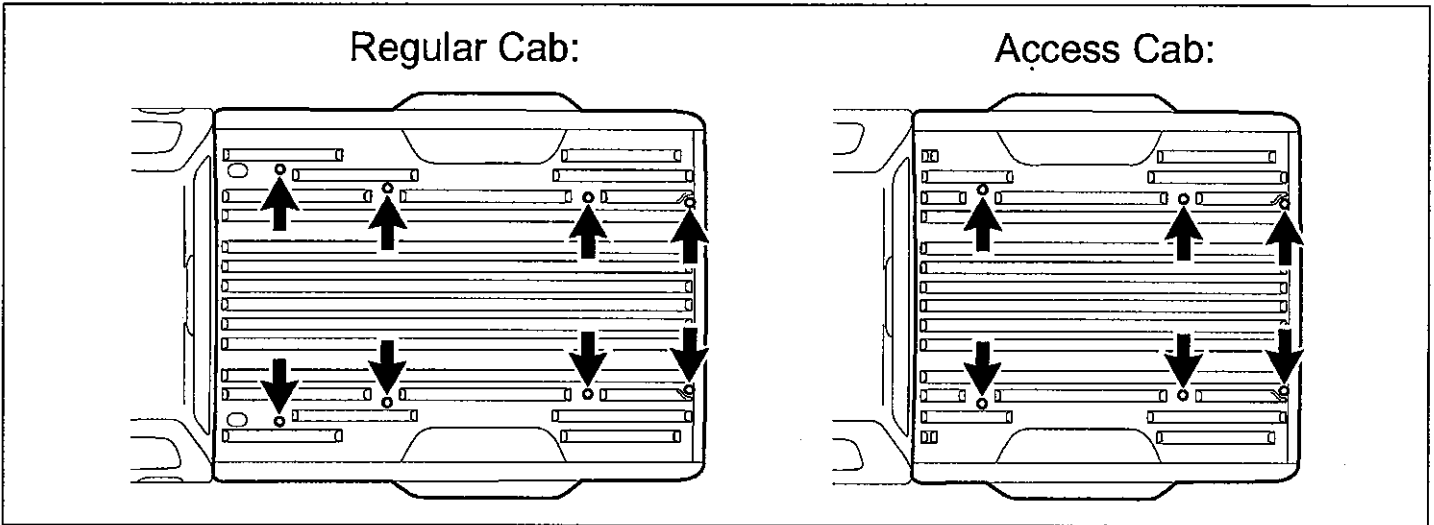

9. REMOVE THE BED ASSEMBLY

- a) Using a Torx ® T55H Tamper Resistant Socket, remove the Torx ® bolts from the bed assembly
 - Regular Cab: 8 Torx ® bolts
 - Access Cab: 6 Torx ® bolts

NOTE:

- Use 4 or more people to remove the bed assembly from the frame.
- Evenly support the bed assembly when removing it.

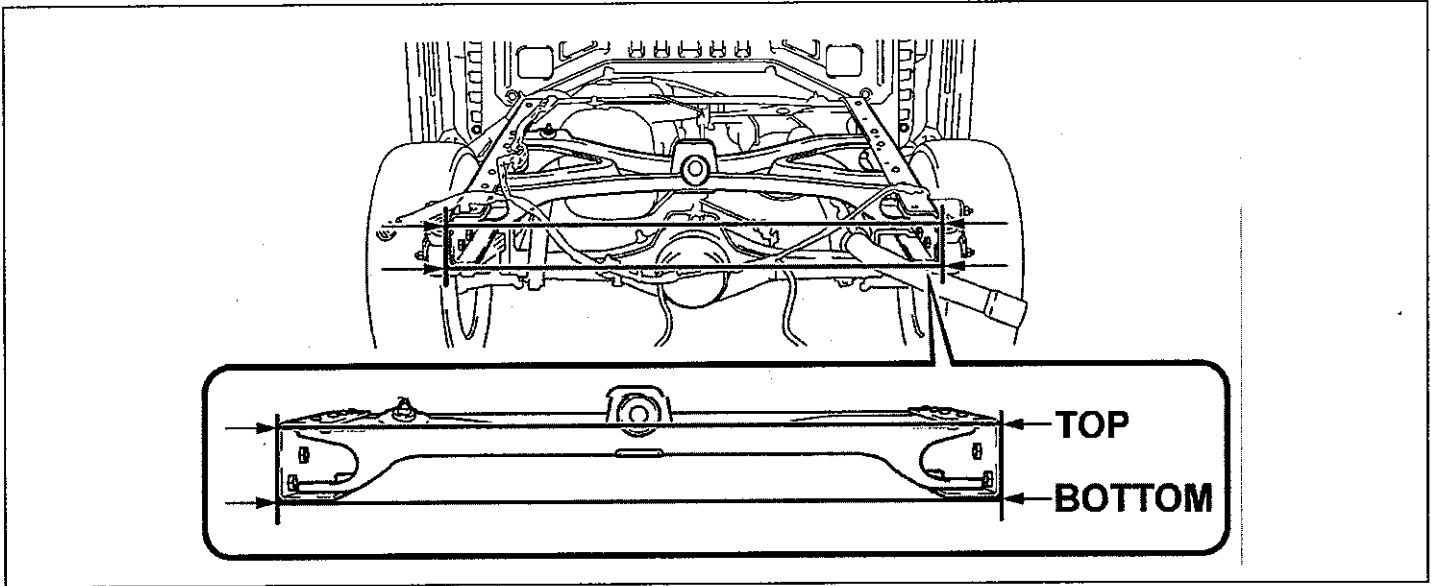

10. MEASURE THE DIMENSIONS OF THE REAR FRAME END

- a) Measure and record the distance between the left and right frame rails for the **TOP** and **BOTTOM** edges of the rear frame end as shown.

TOP: _____ **BOTTOM:** _____

NOTE:

Make sure to measure and record the distances. These measurements will be used for adjustment purposes after the cross member has been installed.

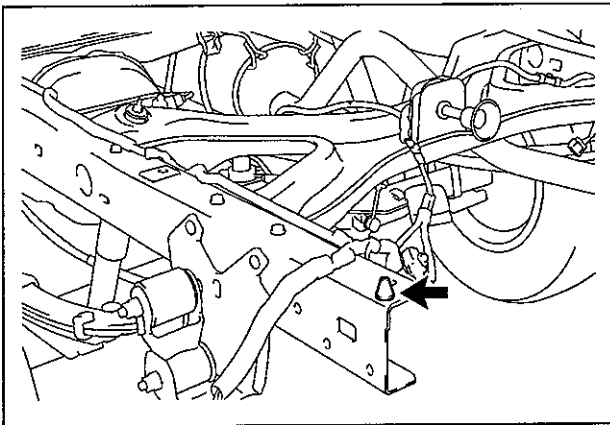

11. REMOVE THE CLIP

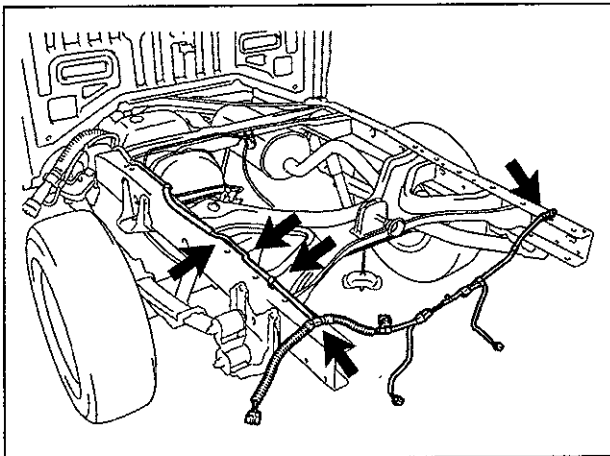

12. DISCONNECT THE FRAME WIRE HARNESS

- a) Remove the 5 wire harness clips.

NOTE:

DO NOT damage the wire harness clip during removal.

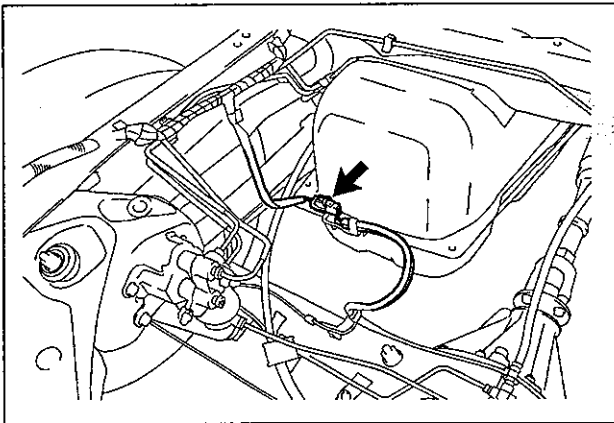

b) Disconnect the ABS connector (*if equipped*).

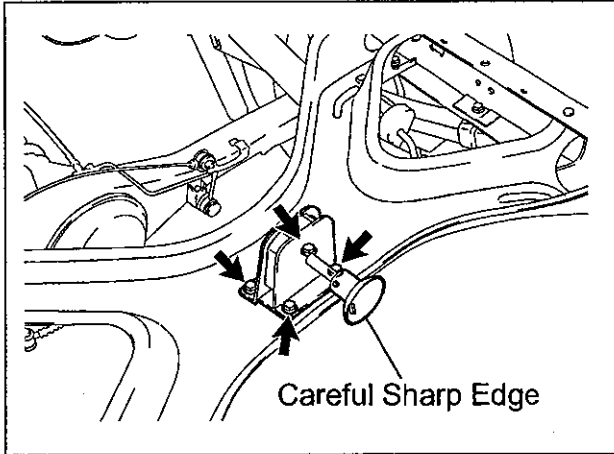

13. REMOVE THE SPARE TIRE CARRIER

a) Remove the 4 bolts and the spare tire carrier.

NOTE:

The edge of the spare tire carrier is sharp, take care when removing.

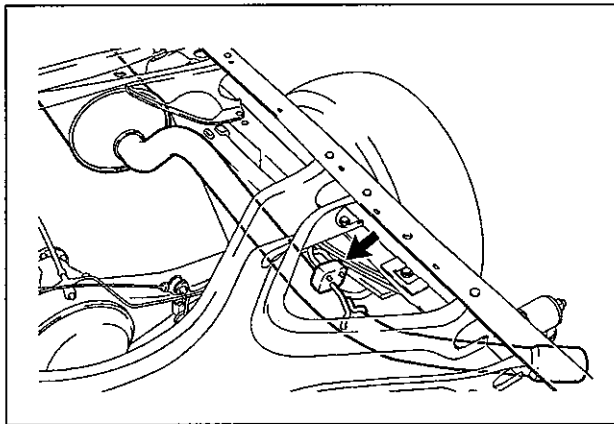

14. REMOVE THE EXHAUST PIPE HANGER

a) Remove the exhaust pipe hanger from the frame.

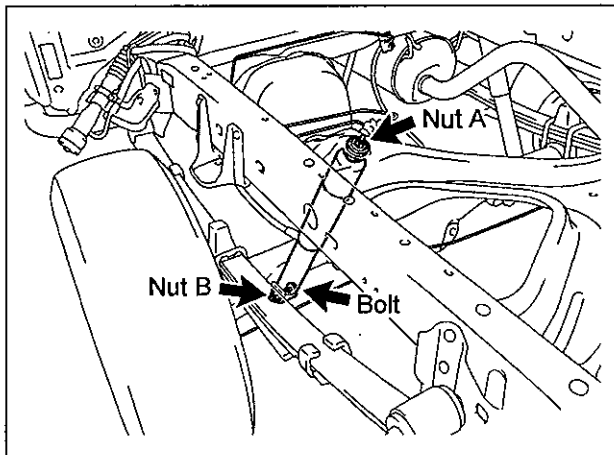

15. REMOVE THE REAR SHOCK ABSORBER LH

a) Remove the 2 nuts, bolt and the rear shock absorber LH.

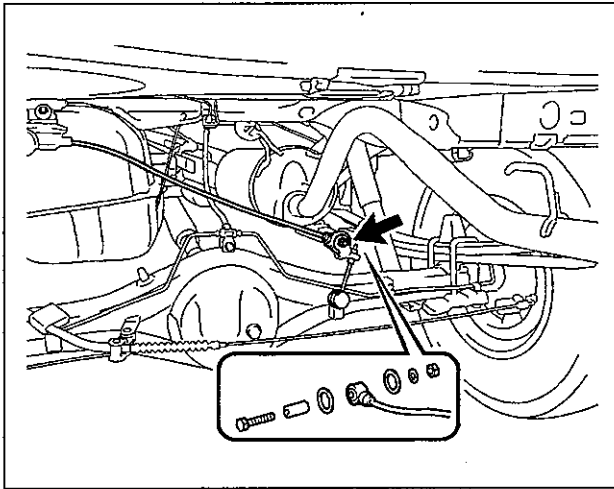

16. DISCONNECT THE LSPV AND LOAD SENSING SPRING

- a) Remove the nut, washer and bolt, and then disconnect the load sensing spring.
- b) Remove the 2 washers and collar from the load sensing spring to prevent them from falling off.

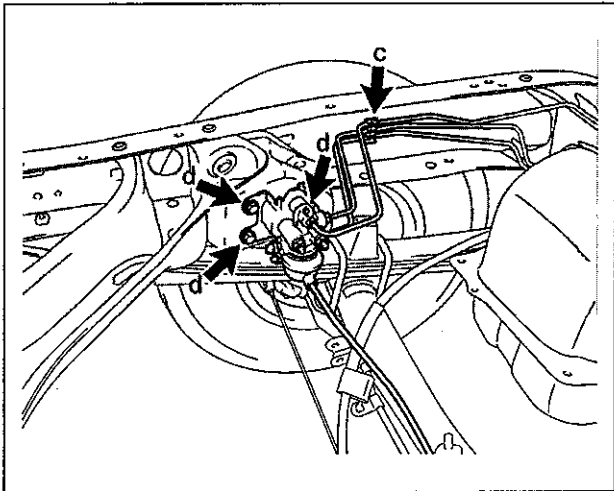

- c) Disconnect the brake line clip.
- d) Remove the 3 bolts and disconnect the LSPV assembly.

NOTE:

- **DO NOT** damage the brake line clip during removal.
- **Visually inspect the LSPV for any damage of fluid leakage. Replace the LSPV if damage or fluid leakage is found.**

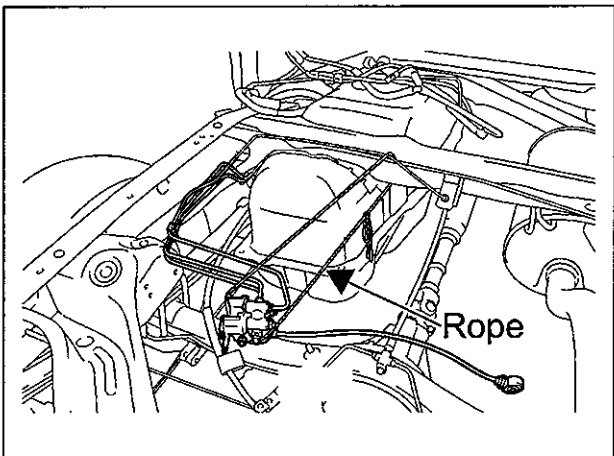

- e) Suspend the LSPV with a rope this will protect the brake lines from damage and deformation.



- When using an air chisel and air hammer wear protective eyewear, ear plugs and gloves.
- Please have ALL personnel near the work area wear ear plugs when the air chisel and air hammer are in use.

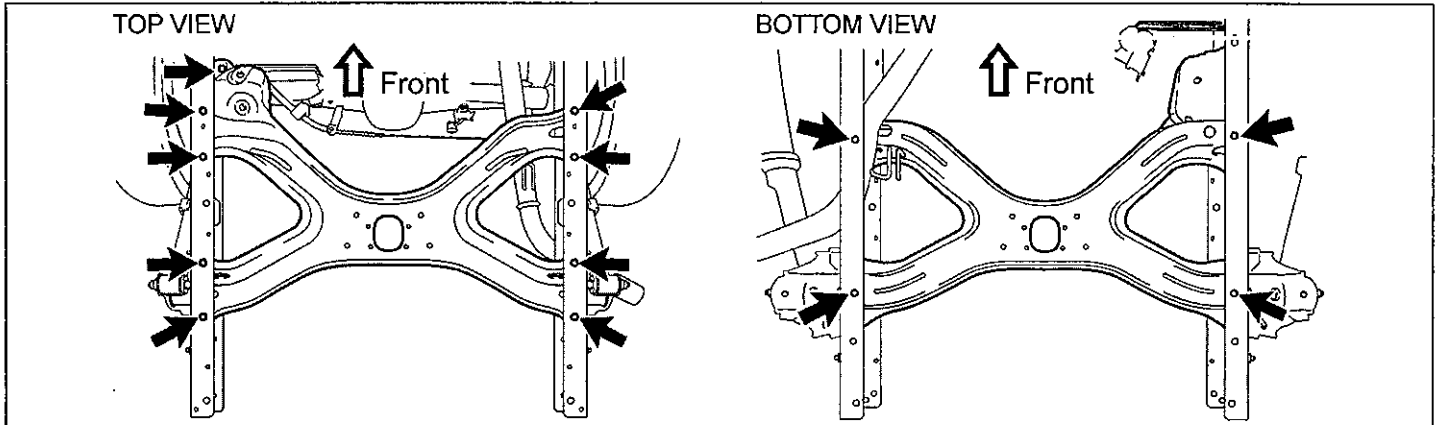

17. REMOVE THE REAR FRAME CROSS MEMBER

- a) Using an air chisel cut off the 13 rivet heads.

NOTE:

- Always wear protective eyewear, ear plugs and gloves when using an air chisel and air hammer.
- **DO NOT** allow personnel near the vehicle, as the rivet heads may fly off when cut.
- Cover the cab body to prevent damage from flying debris.

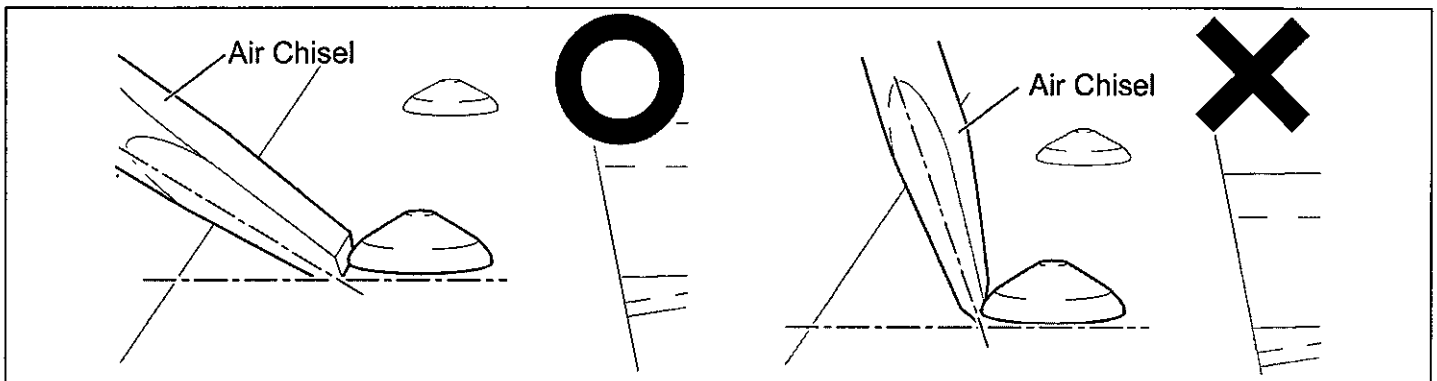

- b) Position the air chisel in between the rivet and side member. **DO NOT** increase the angle the air chisel, doing so may damage frame side member.

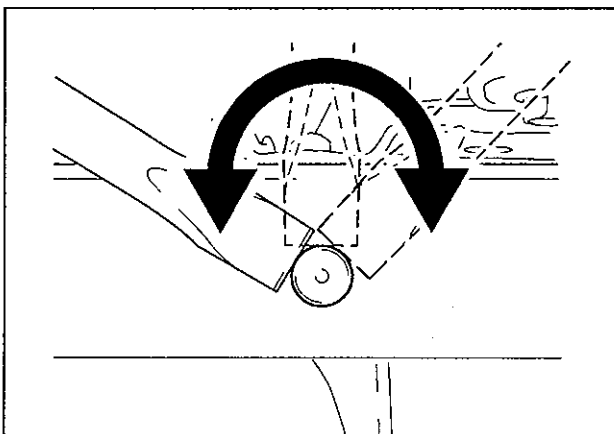

- c) When cutting the rivet head, alternate the position of the air chisel between 3 to 4 different spots.

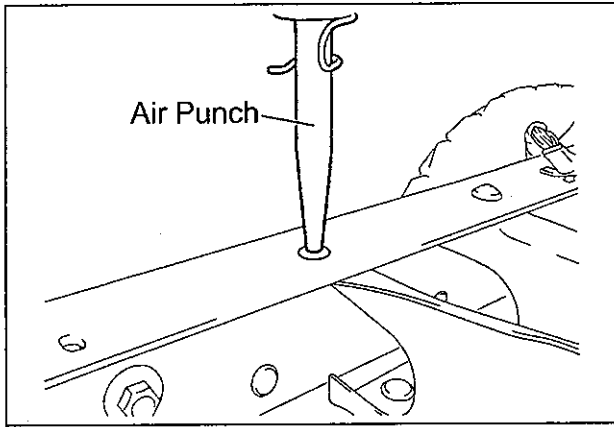

d) Using an air punch remove the 13 rivets.

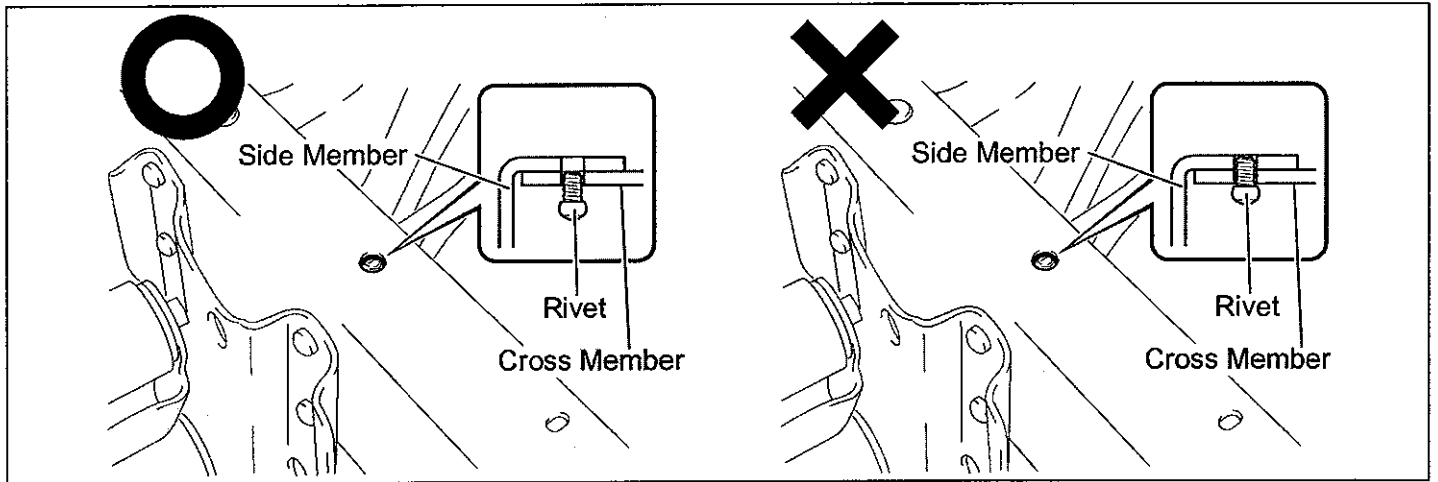

e) The rivet may expand preventing removal with the air punch.

- If the rivet is attached only to the cross member no further action is required.
- If the rivet is attached to the side and cross member, drill a hole in the rivet. Then use a hammer and punch to knock the rivet out.

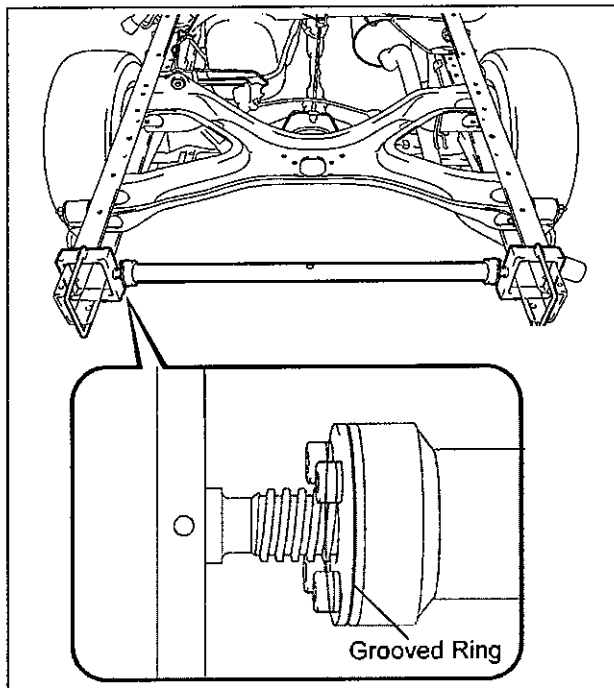

f) Set the frame expansion bar on the vehicle with the groove ring on the left side of the vehicle.

NOTE:

- Verify that the threaded section of the frame expansion bar is properly greased.
- If grease is needed, apply disulfide molybdenum grease to the threaded section before use.

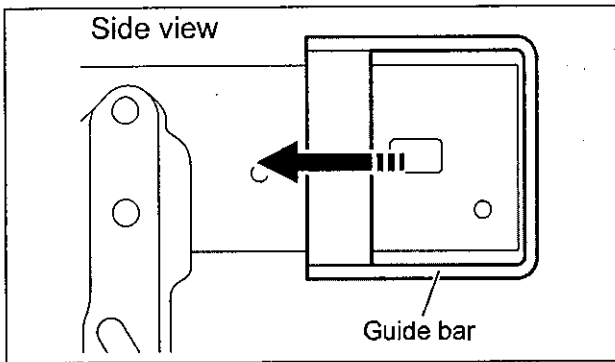

- g) Push the expansion bar until both guide bars contact the frame.

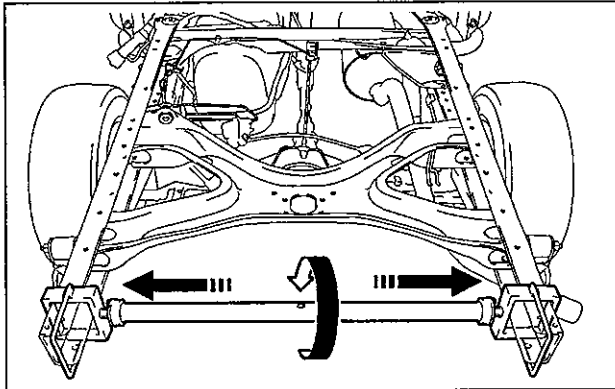

- h) Using the frame expansion bar, expand the ends of the frame rails by 4.33 in. (110 mm).

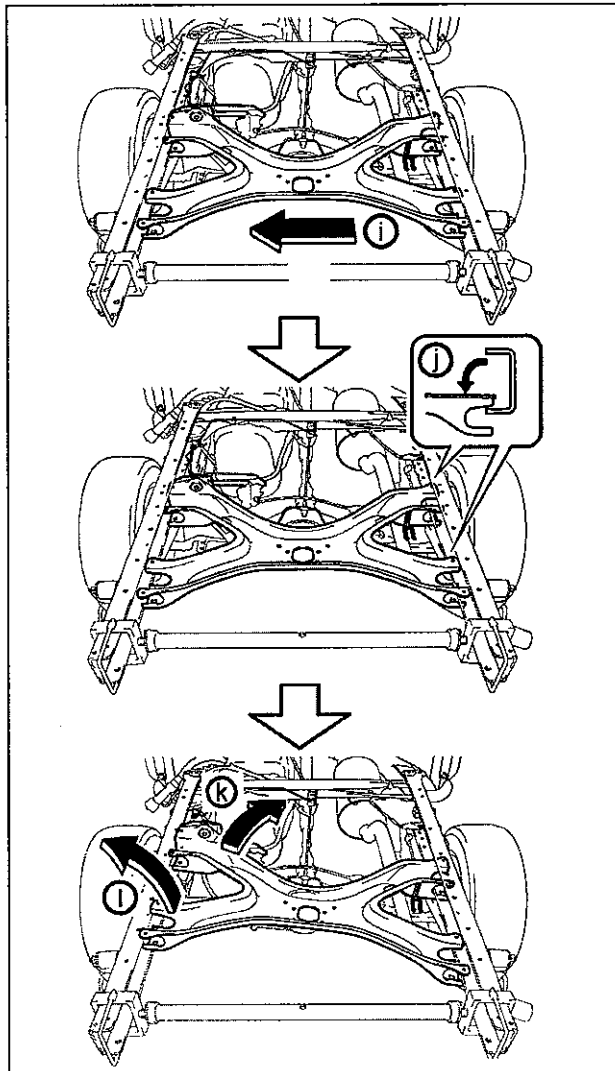

- i) Push the rear frame cross member towards the left of the vehicle as shown.

- j) Lower the right side of the rear frame cross member one notch as shown.

- k) From the left side of the vehicle, slightly twist the rear frame cross member to the right and lift up to remove as shown.

NOTES:

- Use 2 people to remove the rear frame cross member.
- DO NOT remove the expansion bar.

F. REAR FRAME CROSS MEMBER INSTALLATION

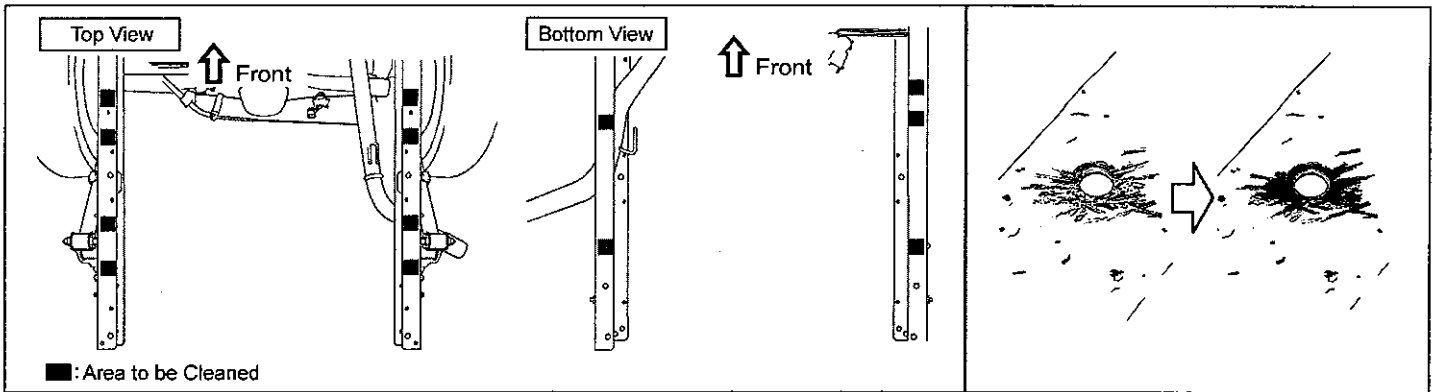

1. PREPARE AND CLEAN THE BOLT MOUNTING SURFACE

- Using 80 grit sandpaper, remove any scratches and uneven areas from where the rivets were removed.
- Sand the surfaces until they are smooth and even.

NOTE:

- Any unevenness in the surface can cause the bolts to loosen.
- Make sure the surface is completely even before proceeding to the next step.

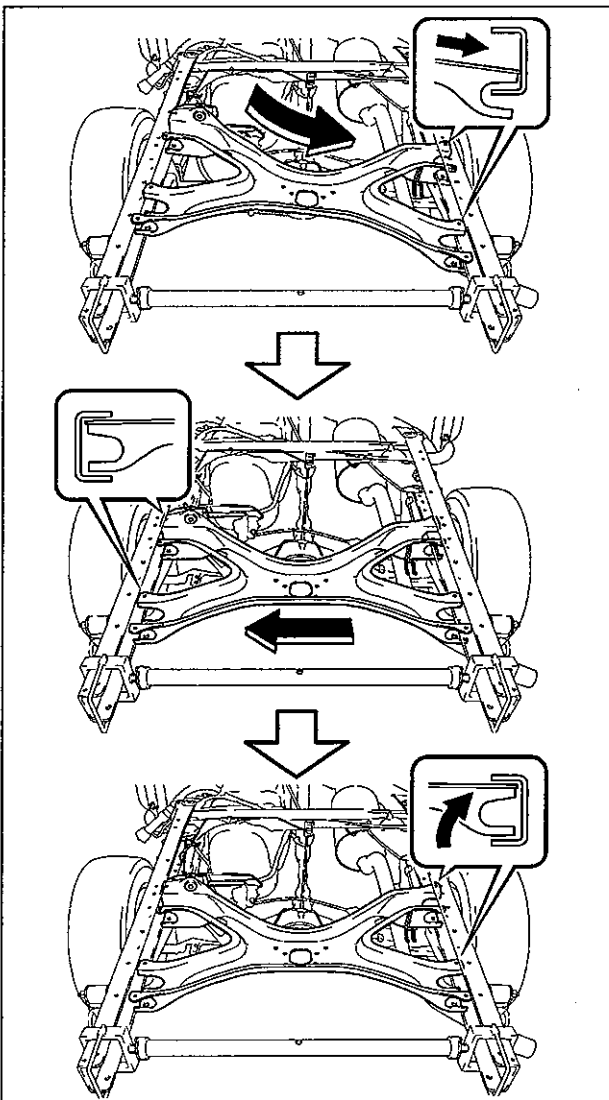

2. INSTALL THE **NEW** FRAME REAR CROSS MEMBER

- From the left side of the vehicle, insert the **NEW** rear frame cross member and set the right notches in the position shown.

NOTES:

Use 2 people to install the **NEW** rear frame cross member.

- Slightly twist the **NEW** frame rear cross member and set the left side in the side member as shown.
- Push the **NEW** frame rear cross member towards the left and set the right side in the side member as shown.

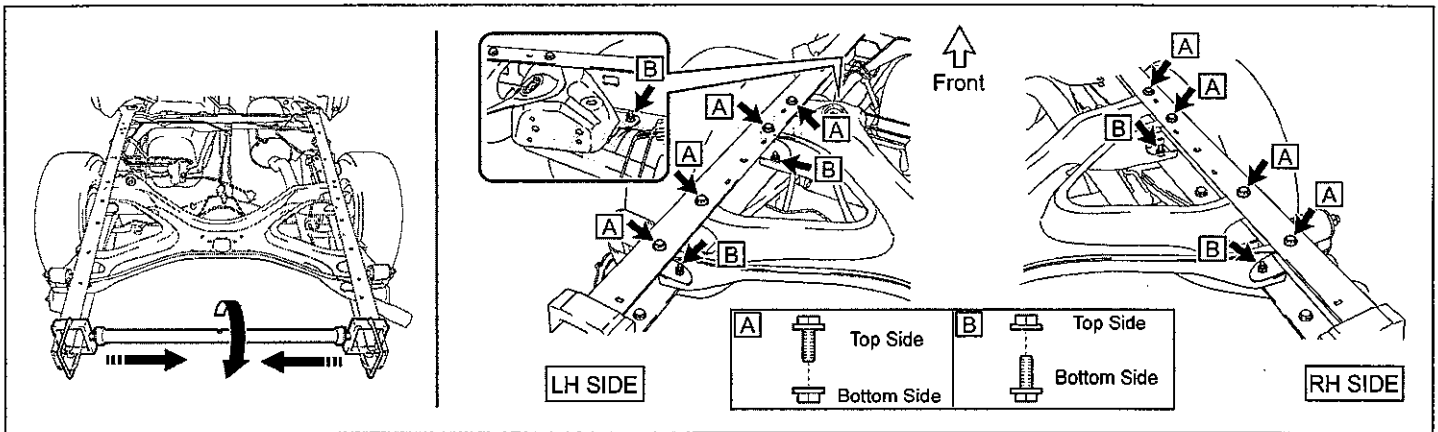

3. INSTALL THE BOLTS AND NUTS

- a) While shortening the frame expansion bar, align the side member and cross member holes and temporarily install 13 **NEW** bolts and nuts.

NOTES:

- **DO NOT** fully tighten the bolts and nuts at this time.
- For the lower section of the side member, insert the bolts from the bottom side.

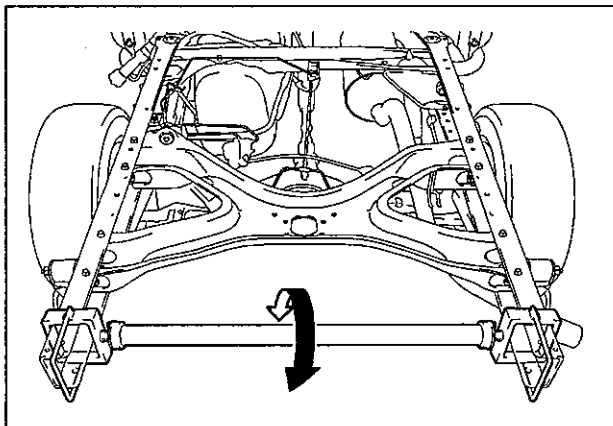

- b) After temporarily installing the bolts and nuts, measure the distance between the left and right frame rails for the **TOP** and **BOTTOM** edges of the rear frame end.
- c) Compare the new measurements to the ones taken in step "9. MEASURE THE DIMENSIONS OF THE REAR FRAME END" during rear frame cross member removal process, and adjust the frame expansion bar until they match.

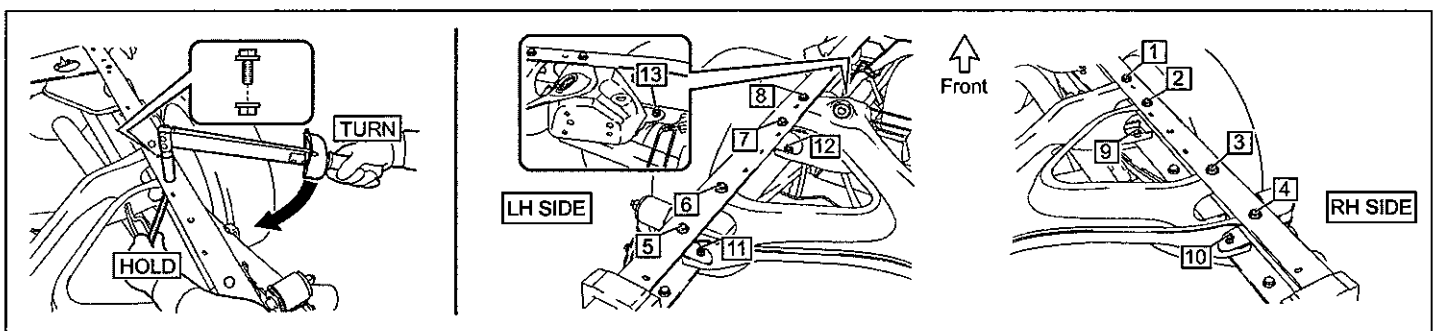

4. TIGHTEN THE BOLTS AND NUTS

- a) In the order illustrated, **tighten each bolt to specification while holding the nut.**

Torque Specification: 54 N·m (551 kgf·cm, 40 ft·lbf)

NOTE:

- **DO NOT** tighten the nut.
- Tighten the bolt while holding the nut.

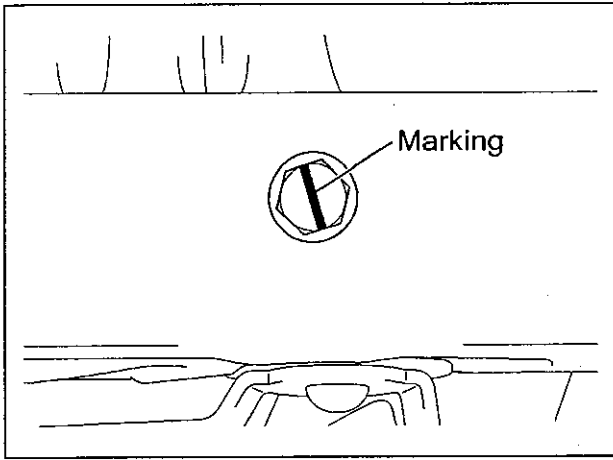

- b) Mark the tightened bolts as shown for verification.
- c) Remove the frame expansion bar.

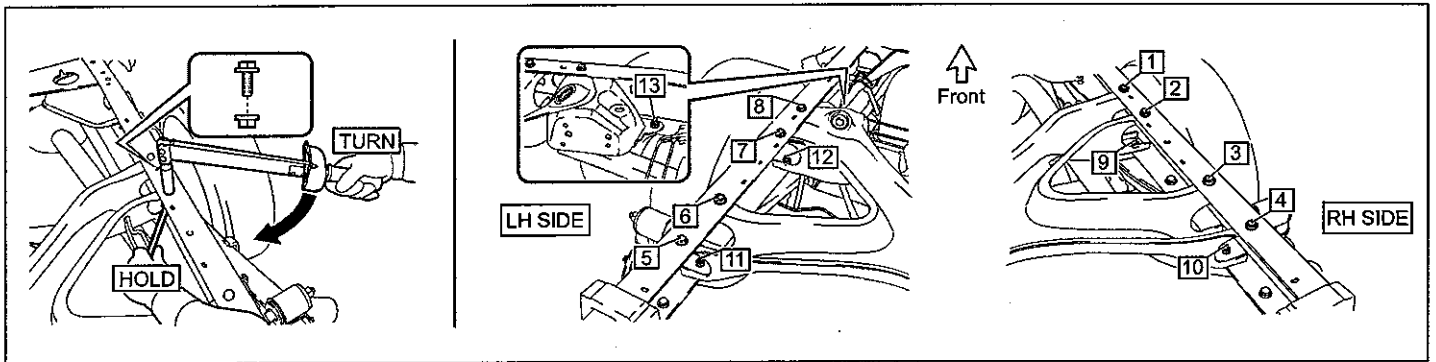

5. RETIGHTEN THE BOLTS AND NUTS

- a) In the order illustrated, retighten each bolt to specification while holding the nut.

Torque Specification: 54 N·m (551 kgf·cm, 40 ft·lbf)

NOTE:

- **DO NOT** tighten the nut.
- **Tighten the bolt while holding the nut.**

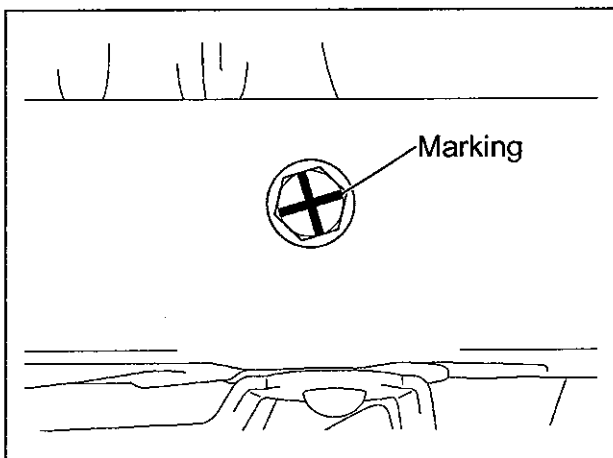

- b) Mark the tightened bolts as shown for verification.
- c) Verify that every bolt has an X mark on the head.

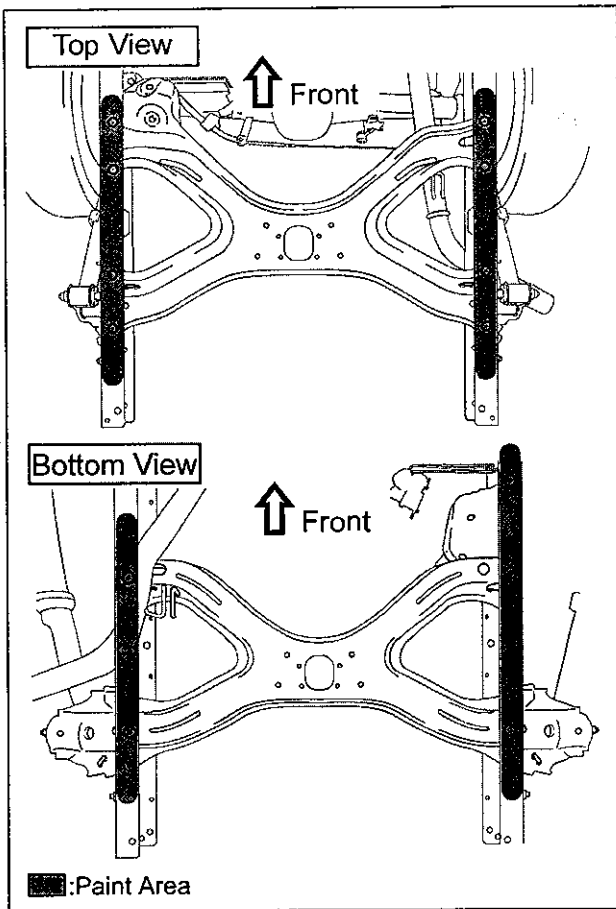

- d) Apply paint (chassis black or black anti-corrosive paint) to the top and bottom areas on the side member as shown.

NOTE:

Confirm all the bolts are tightened before applying paint to the side member.

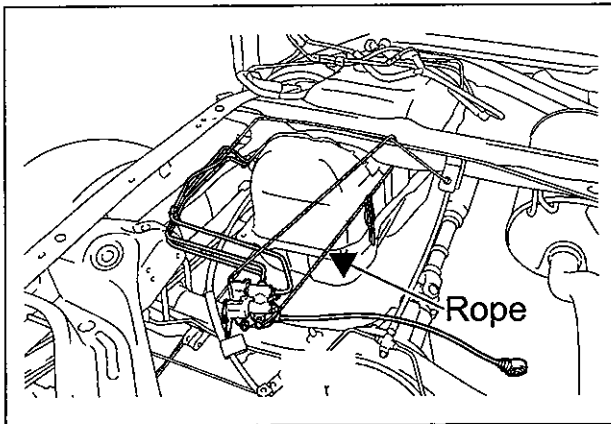

6. RECONNECT THE LSPV AND LOAD SENSING SPRING

- a) Remove the rope supporting the LSPV.

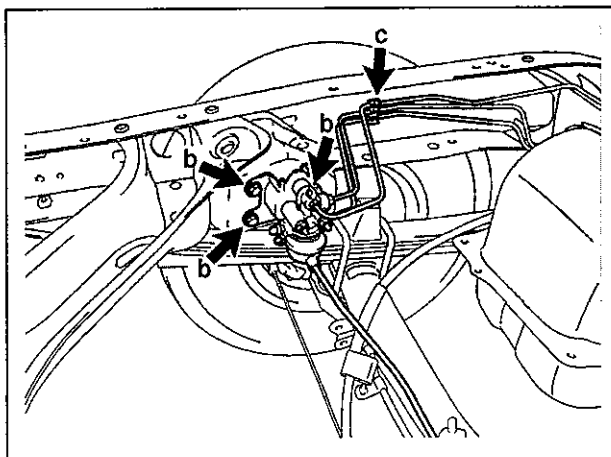

- b) Reinstall the LSPV with the 3 bolts and tighten to specification.

Torque Specification: 29 N·m (296 kgf·cm, 21 ft·lbf)

- c) Reconnect the brake line clip.

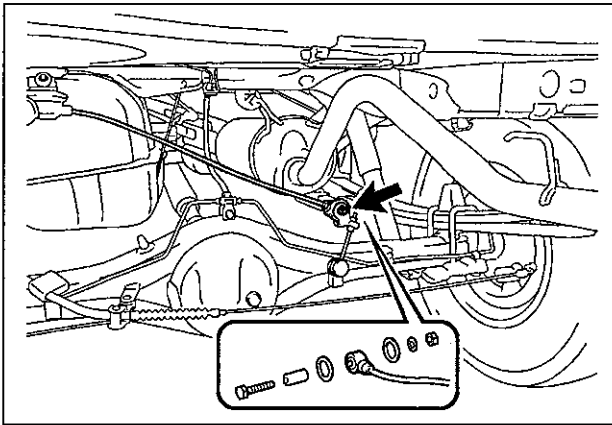

- d) Reinstall the collar and 2 washers to the load sensing spring.
- e) Reinstall the load sensing spring with the bolt, washer and nut, and then tighten to specification.

Torque Specification: 18 N·m (184 kgf-cm, 13 ft-lbf)

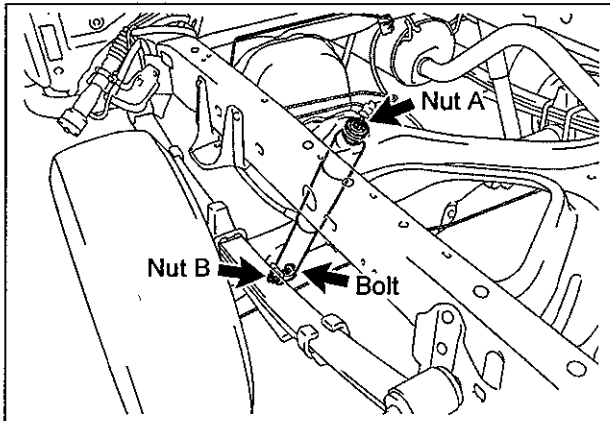

7. REINSTALL THE REAR SHOCK ABSORBER LH

- a) Reinstall the rear shock absorber LH with the bolt and 2 nuts, and tighten to specification.

Torque Specification:

Bolt – 87 N·m (887 kgf-cm, 64 ft-lbf)

Nut A– 20 N·m (204 kgf-cm, 15 ft-lbf)

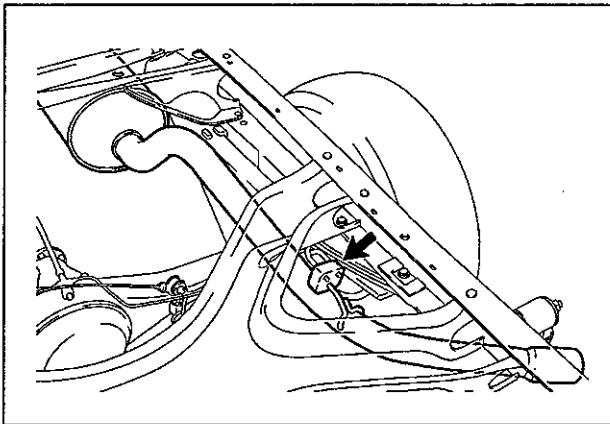

8. REINSTALL THE EXHAUST PIPE HANGER

- a) Reinstall the exhaust pipe hanger to the frame.

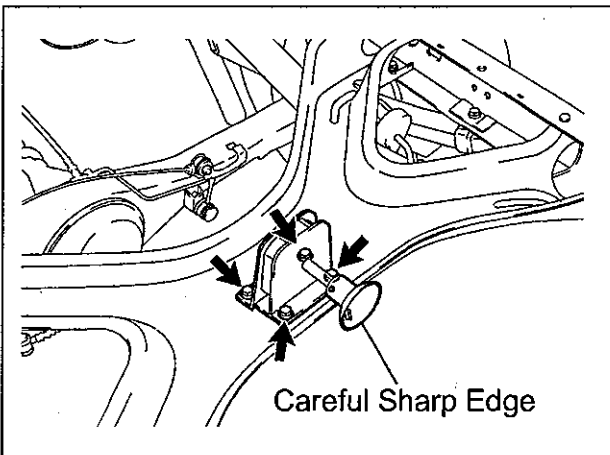

9. REINSTALL THE SPARE TIRE CARRIER

- a) Reinstall the spare tire carrier with the 4 bolts, and tighten to specification.

Torque Specification: 20 N·m (204 kgf-cm, 15 ft-lbf)

NOTE:

The edge of the spare tire carrier is sharp, take care when installing.

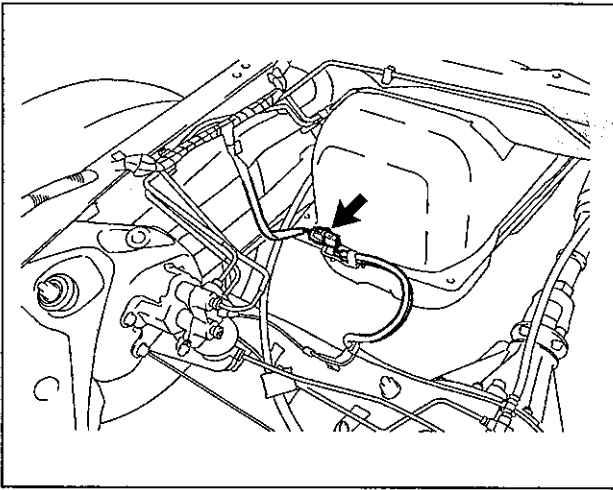

10. RECONNECT THE FRAME WIRE HARNESS

- a) Reconnect the ABS connector *(if equipped)*.

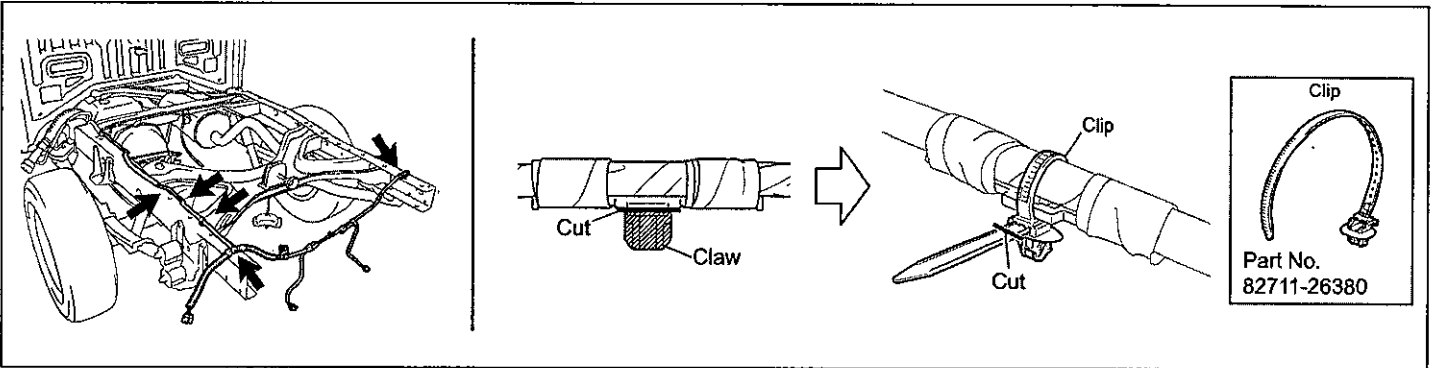

- b) Reinstall the 5 wire harness clips.

NOTE:

If the clip(s) indicated for the frame wire harness is damaged or broken, cut off the damaged claw and replace it with part number 82711-26380 as shown above.

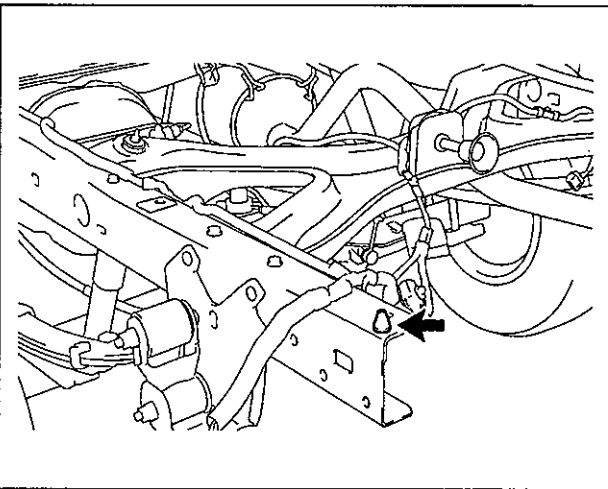

11. REINSTALL THE CLIP

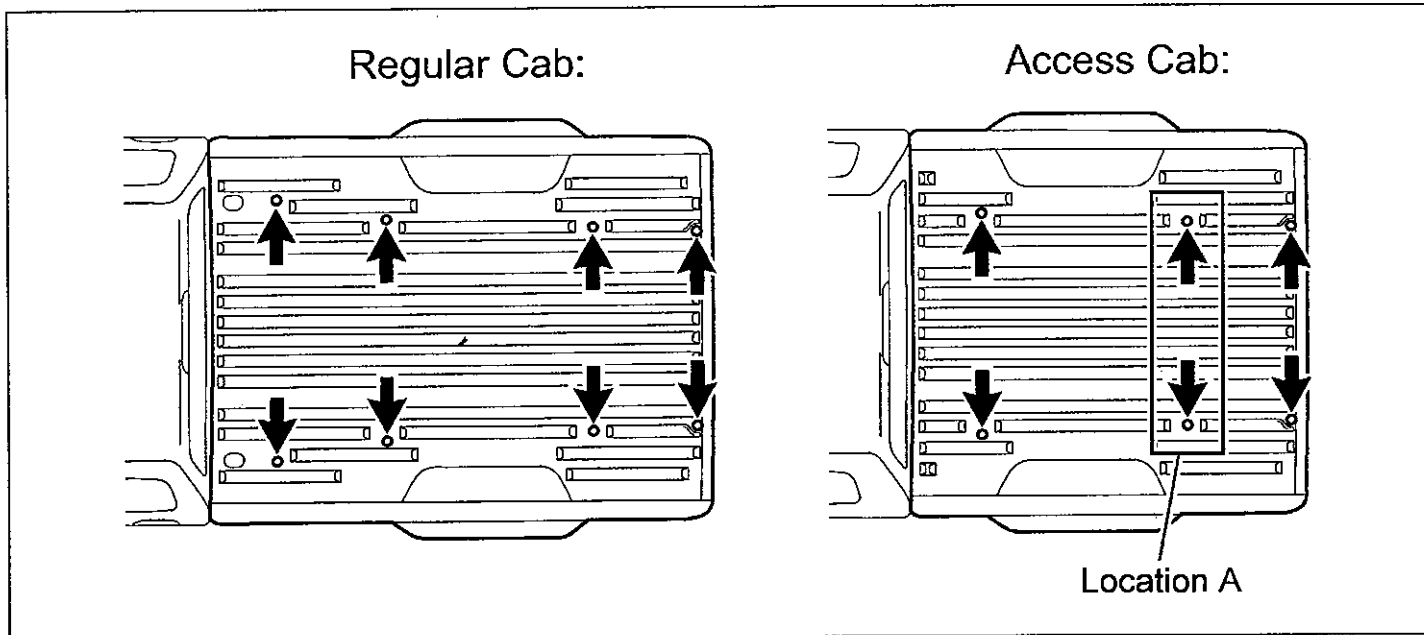

12. REINSTALL THE BED ASSEMBLY

- a) Using a Torx® T55H Tamper Resistant Socket, reinstall the Torx® bolts to the bed assembly and tighten to specification.
 - Regular Cab: 8 Torx® bolts
 - Access Cab: 6 Torx® bolts

Torque Specification: 86 N·m (877 kgf·cm, 63 ft·lbf)

NOTE:

- If a Torx® bolt is damaged or broken, use part number 64189-0C010. This part number is not listed in the parts catalog. Please note on side step bed vehicles, Torx® bolt 64189-0C010 cannot be used to replace a damaged or broken bolt in location "A", use the recommended part listed in the catalog.
- Use 4 or more people to reinstall the bed assembly from the frame.
- Evenly support the bed assembly when reinstalling it.

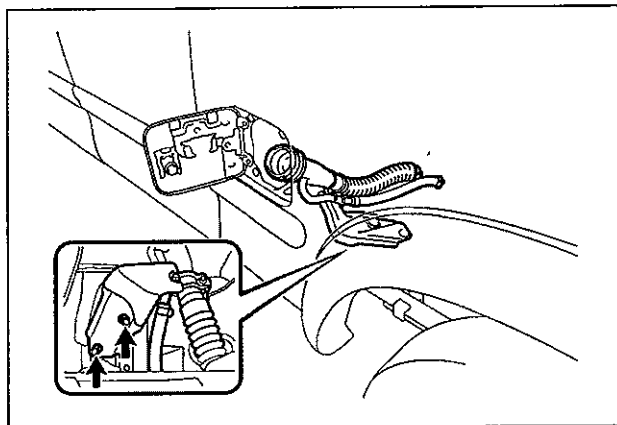

13. RECONNECT THE FUEL INLET PIPE

- a) Reinstall the fuel pipe inlet with the 2 nuts and tighten to specification.

Torque Specification: 27 N·m (275 kgf·cm, 20 ft·lbf)

14. REINSTALL THE FUEL TANK FILLER PIPE SHIELD

15. REINSTALL THE REAR MUDGUARDS (IF EQUIPPED)

16. REINSTALL THE SPARE TIRE

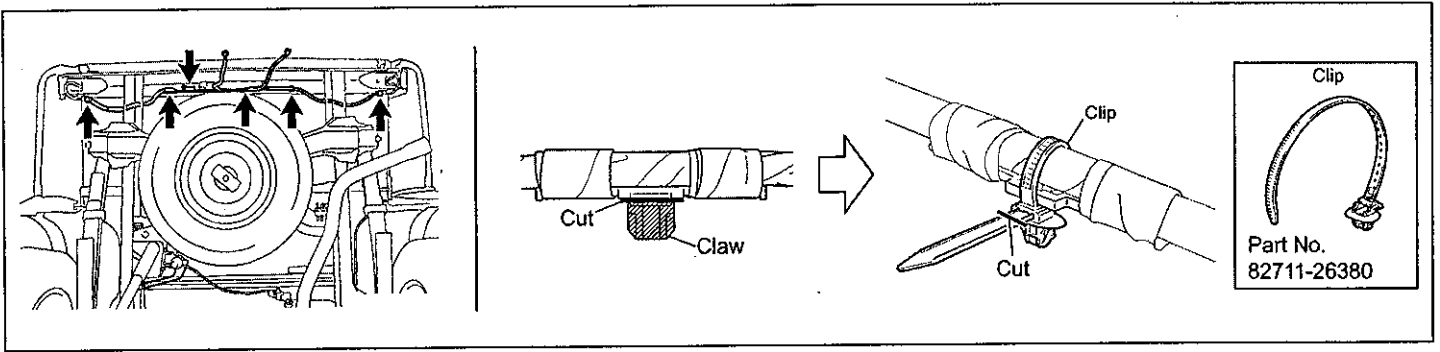

17. RECONNECT THE FRAME WIRE HARNESS

- a) Reconnect the frame wire harness to the bed assembly with the clips.
- b) Reconnect the connectors.

NOTE:

- The number of connectors and clips may differ depending on the vehicle specification.
- If the clip(s) indicated for the frame wire harness is damaged or broken, cut off the damaged claw and replace it with part number 82711-26380 as shown above.

18. REINSTALL THE TRAILER HITCH (IF EQUIPPED)

19. REINSTALL THE REAR BUMPER ASSEMBLY

20. REINSTALL THE CENTER REAR BUMPER PAD

21. REINSTALL THE LICENSE PLATE LIGHTS

22. TEST DRIVE THE VEHICLE

- a) Test drive the vehicle and inspect for any issues, abnormalities, drivability concerns, etc.

VII. APPENDIX

As required by Federal Regulations, please make sure all recalled parts (original parts) removed from the vehicle are disposed of in a manner in which they will not be reused, ***unless requested for parts recovery return.***